



Fast Infrared Transceiver Module Family (FIR, 4 Mbit/s) for 3.3 V and 5.0 V operation



Description

The TFDU6100E, TFDS6500E, and TFDT6500E are a family of low-power infrared transceiver modules compliant to the IrDA 1.2 standard for fast infrared (FIR) data communication, supporting IrDA speeds up to 4.0 Mbit/s, HP-SIR, Sharp ASK and carrier based remote control modes up to 2 MHz. Integrated within the transceiver modules are a photo PIN diode, an infrared emitter (IRED), and a low-power CMOS control IC to provide a total front-end solution in a single package. Vishay Telefunken's FIR transceivers are available in three package options, including our Baby Face package (TFDU6100E), the smallest FIR

transceiver available on the market. This wide selection provides flexibility for a variety of applications and space constraints. The transceivers are capable of directly interfacing with a wide variety of I/O chips which perform the modulation/ demodulation function, including National Semiconductor's PC87338, PC87108 and PC87109, SMC's FDC37C669, FDC37N769 and CAM35C44, and Hitachi's SH3. At a minimum, a current-limiting resistor in series with the infrared emitter and a V_{CC} bypass capacitor are the only external components required to implement a complete solution.

Features

- Compliant to IrDA 1.2 (Up to 4 Mbit/s), HP-SIR, Sharp ASK and TV Remote
- For 3.3 V and 5.0 V Operating Voltage
- Low-Power Consumption (3 mA Supply Current)
- Power Shutdown Mode (1 μA Shutdown Current)
- Three Surface Mount Package Options
 - Universal (9.7 × 4.7 × 4.0 mm)
 - Side View (13.0 × 5.95 × 5.3 mm)
 - Top View (13.0 × 7.6 × 5.95 mm)
- High Efficiency Emitter
- Baby Face (Universal) Package Capable of Surface Mount Solderability to Side and Top View Orientation
- Directly Interfaces with Various Super I/O and Controller Devices
- Built-In EMI Protection – No External Shielding Necessary
- Few External Components Required
- Backward Compatible to all Telefunken SIR and FIR Infrared Transceivers

Applications

- Notebook Computers, Desktop PCs, Palmtop Computers (Win CE, Palm PC), PDAs
- Digital Still and Video Cameras
- Printers, Fax Machines, Photocopiers, Screen Projectors
- Telecommunication Products (Cellular Phones, Pagers)
- Internet TV Boxes, Video Conferencing Systems
- External Infrared Adapters (Dongles)
- Medical and Industrial Data Collection Devices

Package Options

TFDU6100E
Baby Face (Universal)



TFDS6500E
Side View



TFDT6500E
Top View



This product is currently in development. Inquiries regarding the status of this product should be directed to Vishay Telefunken Marketing.

Ordering Information

Part Number	Qty / Reel	Description
TFDU6100E-TR3	1000 pcs	Oriented in carrier tape for side view surface mounting
TFDU6100E-TT3	1000 pcs	Oriented in carrier tape for top view surface mounting
TFDS6500E-TR3	750 pcs	
TFDT6500E-TR3	750 pcs	

Functional Block Diagram

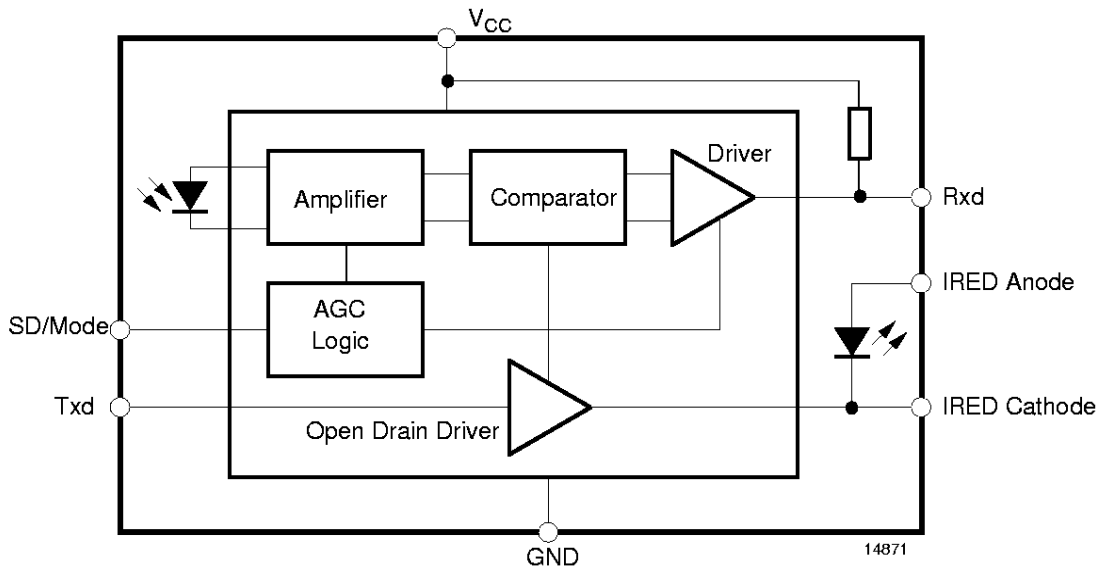

Figure 1. Functional Block Diagram

Pin Description

Pin Number		Function	Description	I/O	Active
"U" and "T" Option	"S" Option				
1	8	IRED Anode	IRED anode, to be externally connected to V_{CC} through a current control resistor		
2	1	IRED Cathode	IRED cathode, internally connected to driver transistor		
3	7	Txd	Transmit Data Input	I	HIGH
4	2	Rxd	Received Data Output, push-pull CMOS driver output capable of driving a standard CMOS or TTL load. No external pull-up or pull-down resistor is required (pin is floating when device is in shutdown mode)	O	LOW
5	6	SD/Mode	Shutdown/Mode	I	HIGH
6	3	V_{CC}	Supply Voltage		
7	5	Mode	HIGH: FIR; LOW: SIR (see chapter "Mode Switching")	I	
8	4	GND	Ground		



“U” Option BabyFace (Universal)

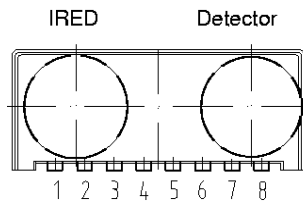

14885

“S” Option Side View

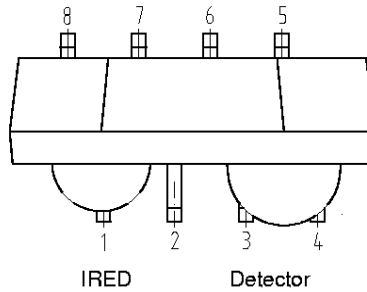

“T” Option Top View

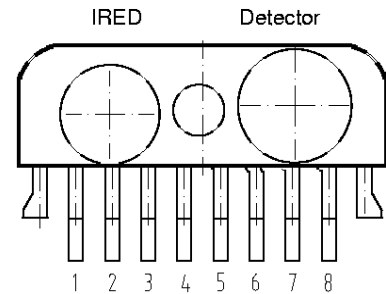

Figure 2. Pinning

Absolute Maximum Ratings

Reference point Pin GND unless otherwise noted.

Typical values are for DESIGN AID ONLY, not guaranteed nor subject to production testing.

Parameters	Test Conditions	Symbol	Min.	Typ.	Max.	Unit
Supply Voltage Range		V_{CC}	-0.5		6	V
Input Currents	For all Pins, Except IRED Anode Pin				10	mA
Output Sinking Current					25	mA
Power Dissipation	See Derating Curve	P_D			350	mW
Junction Temperature		T_J			125	°C
Ambient Temperature Range (Operating)		T_{amb}	-25		+85	°C
Storage Temperature Range		T_{stg}	-25		+85	°C
Soldering Temperature	See Recommended Solder Profile				240	°C
Average Output Current		$I_{IRED (DC)}$			130	mA
Repetitive Pulsed Output Current	$<90 \mu s, t_{on} < 20\%$	$I_{IRED (RP)}$			600	mA
IRED Anode Voltage		$V_{IRED A}$	-0.5		$V_{CC} + 1.5$	V
Transmitter Data Input Voltage		V_{Txd}	-0.5		$V_{CC} + 0.5$	V
Receiver Data Output Voltage		V_{Rxd}	-0.5		$V_{CC} + 0.5$	V
Virtual Source Size	Method: (1-1/e) encircled energy	d	2.5	2.8		mm
Maximum Intensity for Class 1 Operation of IEC825-1 or EN60825-1 (worst case IrDA FIR pulse pattern)	EN60825, 1997				320	mW/sr

Electrical Characteristics

$T_{amb} = 25^{\circ}\text{C}$, $V_{CC} = 3.0\text{ V}$ to 5.25 V unless otherwise noted.

Typical values are for DESIGN AID ONLY, not guaranteed nor subject to production testing.

Parameters	Test Conditions / Pins	Symbol	Min.	Typ.	Max.	Unit
Transceiver						
Supply Voltage		V_{CC}	3.0		5.25	V
Dynamic Supply Current	Receive mode only In transmit mode, add additional 100 mA (typ) for IRED current					
	SD = Low, $E_e = 0\text{ klx}$	I_{CC}		3	4.5	mA
	SD = Low, $E_e = 1\text{ klx}^*)$	I_{CC}		3	4.5	mA
Standby Supply Current	SD = High, Mode = floating, Txd = 0 V T = 25°C , $E_e = 0\text{ klx}$ T = 25°C , $E_e = 1\text{ klx}^*)$	I_{SD}			1 1.5	μA μA
	SD = High, T = 85°C , Mode = floating, Txd = 0 V Not Ambient Light Sensi- tive	I_{SD}			5	μA
Operating Temperature Range		T_A	-25		+85	$^{\circ}\text{C}$
Output Voltage Low	$R_{load} = 2.2\text{ k}\Omega$, $C_{load} = 15\text{ pF}$	V_{OL}		0.5	0.8	V
Output Voltage High	$R_{load} = 2.2\text{ k}\Omega$, $C_{load} = 15\text{ pF}$	V_{OH}	$V_{CC}-0.5$			V
Input Voltage Low		V_{IL}	0		0.8	V
Input Voltage High	CMOS level	V_{IH}	$0.9 \times V_{CC}$			V
	TTL level, $V_{CC} \geq 4.5\text{ V}$	V_{IH}	2.4			V
Input Leakage Current		I_L	-10		+10	μA
Input Capacitance		C_I			5	pF

*) Standard Illuminant A



Optoelectronic Characteristics

T_{amb} = 25°C, V_{CC} = 3.0 V to 5.25 V unless otherwise noted.

Typical values are for DESIGN AID ONLY, not guaranteed nor subject to production testing.

Parameters	Test Conditions	Symbol	Min.	Typ.	Max.	Unit
Receiver						
Minimum Detection Threshold Irradiance, SIR Mode	TFDS6500E/TFDT6500E 115.2 kbit/s, 3.0 V, $\lambda = 850 \text{ nm} - 900 \text{ nm}$	E _e		20	35	mW/m ²
	TFDU6100E 115.2 kbit/s, 3.0 V, $\lambda = 850 \text{ nm} - 900 \text{ nm}$	E _e		25	40	mW/m ²
Minimum Detection Threshold Irradiance, FIR Mode	TFDS6500E/TFDT6500E 1.152 Mbit/s, 3.0 V, $\lambda = 850 \text{ nm} - 900 \text{ nm}$	E _e		65	90	mW/m ²
	TFDU6100E 1.152 Mbit/s, 3.0 V, $\lambda = 850 \text{ nm} - 900 \text{ nm}$	E _e		85	100	mW/m ²
Maximum Detection Threshold Irradiance		E _e	5	10		kW/m ²
Logic LOW Receiver Input Irradiance		E _e	4			mW/m ²
Rise Time of Output Signal	10% to 90%, @2.2 k Ω , 15 pF	t _r (Rxd)	10		40	ns
Fall Time of Output Signal	90% to 10%, @2.2 k Ω , 15 pF	t _f (Rxd)	10		40	ns
Rxd Pulse Width of Output Signal, 50%	Input pulse length 20 μ s, 9.6 kbit/s	t _{PW}	1.2	10	20	μ s
	Input pulse length 1.41 μ s, 115.2 kbit/s mode	t _{PW}	1.2		1/2 bit length	μ s
	Input pulse length 217 ns, 1.152 Mbit/s mode	t _{PW}	110		260	ns
	Input pulse length 125 ns, 4.0 Mbit/s mode	t _{PW}	80		175	ns
	Input pulse length 250 ns, 4.0 Mbit/s mode (double pulse)	t _{PW}	200		290	ns
Jitter, Leading Edge	Input Irradiance = 90 mW/m ² , 1.152 Mbit/s mode				10	ns
Latency		t _L			120	μ s
Transmitter						
IREC Operating Current	R1 = 7.2 Ω , V _{CC} = 5.0 V	I _D		0.4	0.55	A
Output Radiant Intensity	V _{CC} = 5.0 V, $\alpha = 0^\circ, 15^\circ$ Txd = High, SD = Low, R1 = 7.2 Ω	I _e	100	140	320	mW/sr
	V _{CC} = 5.0 V, $\alpha = 0^\circ, 15^\circ$ Txd = Low, SD = High, (Receiver is inactive as long as SD = High) R1 = 7.2 Ω	I _e			0.04	mW/sr
Radiant Intensity, Half – Intensity Angle		$\alpha_{1/2}$		± 24		°
Peak – Emission Wavelength		λ_p	880		900	nm

Parameters	Test Conditions	Symbol	Min.	Typ.	Max.	Unit
Optical Rise Time, Fall Time		t_{rop} , t_{fop}	10		40	ns
Optical Overshoot					10	%

Recommended Circuit Diagram

The only required component for designing an IrDA 1.2 compatible design using Telefunken FIR transceivers is a current limiting resistor, R1, to the IRED. However, depending on the entire system design and board layout, additional components may be required (see figure 3).

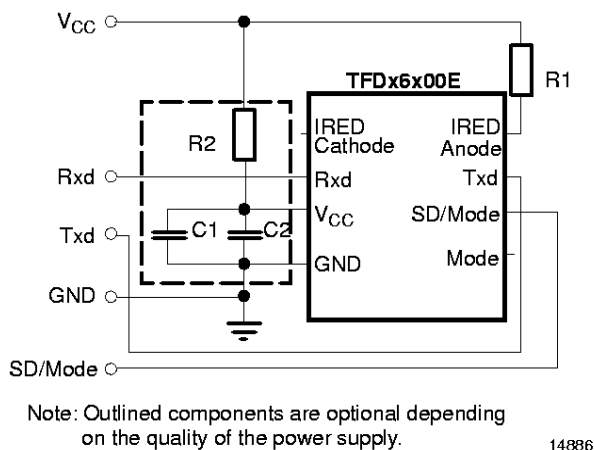

Figure 3. Recommended Application Circuit

Telefunken FIR transceivers integrate a sensitive receiver and a built-in power driver. The combination of both needs a careful circuit board layout. The use of thin, long resistive and inductive wiring should be avoided. The inputs (Txd, SD/Mode) and the output Rxd should be directly (DC) coupled to the I/O circuit.

R1 is used for controlling the current through the IR emitter. For increasing the output power of the IRED, the value of the resistor should be reduced. Similarly, to reduce the output power of the IRED, the value of the resistor should be increased. For typical values of R1 see figure 4. For IrDA compliant operation, a

current control resistor of 7.2Ω is recommended. The upper drive current limitation is dependent on the duty cycle and is given by the absolute maximum ratings on the data sheet.

R2, C1 and C2 are optional and dependent on the quality of the supply voltage V_{CC} and injected noise. An unstable power supply with dropping voltage during transmission may reduce sensitivity (and transmission range) of the transceiver.

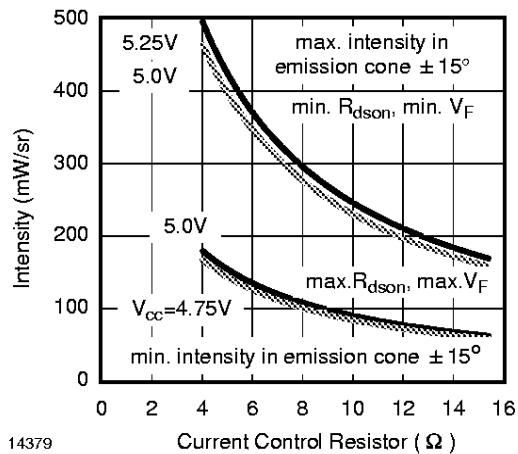

Figure 4. Intensity I_e vs. Current Control Resistor R1

The placement of these parts is critical. It is strongly recommended to position C2 as near as possible to the transceiver power supply pins. A tantalum capacitor should be used for C1 while a ceramic capacitor is used for C2. Also, when connecting the described circuit to the power supply, low impedance wiring should be used.

Table 1. Recommended Application Circuit Components

Component	Recommended Value	Vishay Part Number
C1	4.7 μ F, Tantalum	293D 475X9 016B 2T
C2	0.1 μ F, Ceramic	VJ 1206 Y 104 J XXMT
R1	5 V supply voltage: 7.2Ω , 0.25 W (recommend using two 3.6 Ω , 0.125 W resistors in series) 3.3 V supply voltage: 3.6Ω , 0.25 W (recommend using two 1.8 Ω , 0.125 W resistors in series)	CRCW-1206-3R60-F-RT2 CRCW-1206-1R80-F-RT2
R2	47 Ω , 0.125 W	CRCW-1206-47R0-F-RT2

Mode Switching

The TFDU6100E, TFDS6500E and TFDT6500E power on not with a default mode, therefore the data transfer rate has to be set by a programming sequence as described below or selected by setting the mode pin. Optionally the Mode Pin can be used to statically set the mode (Mode Pin: LOW:SIR, HIGH: 0.576 Mbit/s to 4.0 Mbit/s). When using the Mode Pin, the standby current may increase to about 50 to 60 μ A. In standby mode, the mode input should float to minimize standby current.

The low frequency mode covers speeds up to 115.2 kbit/s. Signals with higher data rates should be detected in the high frequency mode. Lower frequency data can also be received in the high frequency mode but with reduced sensitivity. To switch the transceivers from low frequency mode to the 4.0 Mbit/s mode and vice versa, the programming sequences described below are required.

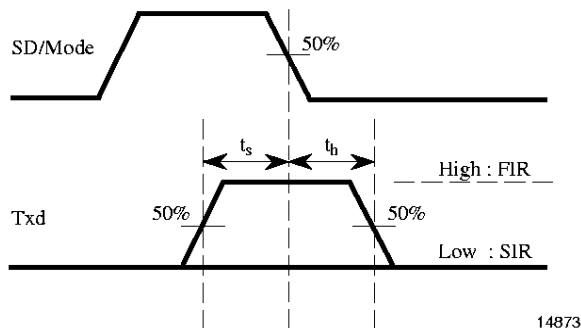

Figure 5. Mode Switching Timing Diagram

Setting to the High Bandwidth Mode (0.576 Mbit/s to 4.0 Mbit/s)

1. Set SD/MODE input to logic "HIGH".
2. Set Txd input to logic "HIGH". Wait $t_s \geq 200$ ns.
3. Set SD/MODE to logic "LOW" (this negative edge latches state of Txd, which determines speed setting).
4. After waiting $t_h \geq 200$ ns Txd can be set to logic "LOW". The hold time of Txd is limited by the maximum allowed pulse length.

Txd is now enabled as normal Txd input for the high bandwidth mode.

Setting to the Lower Bandwidth Mode (2.4 kbit/s to 115.2 kbit/s)

1. Set SD/MODE input to logic "HIGH".
2. Set Txd input to logic "LOW". Wait $t_s \geq 200$ ns.
3. Set SD/MODE to logic "LOW" (this negative edge latches state of Txd, which determines speed setting).
4. Txd must be held for $t_h \geq 200$ ns.

Txd is now enabled as normal Txd input for the lower bandwidth mode.



Recommended SMD Pad Layout

The leads of the device should be soldered in the center position of the pads.

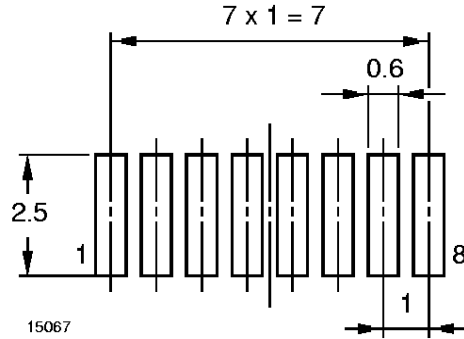

Figure 6. TFDU6100E BabyFace (Universal)

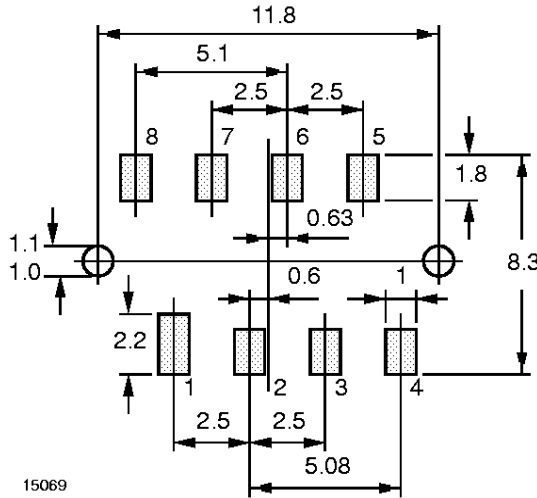

Figure 7. TFDS6500E Side View Package

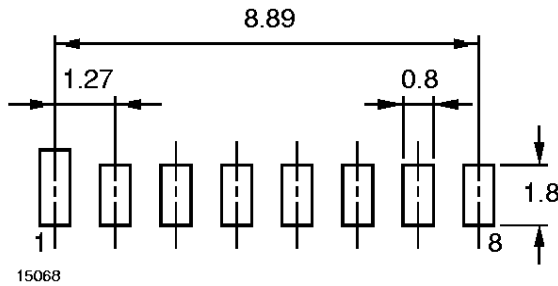

Figure 8. TFDT6500E Top View Package

Note: Leads of the device should be at least 0.3 mm within the ends of the pads. Pad 1 is longer to designate Pin 1 connection to transceiver.



Recommended Solder Profile

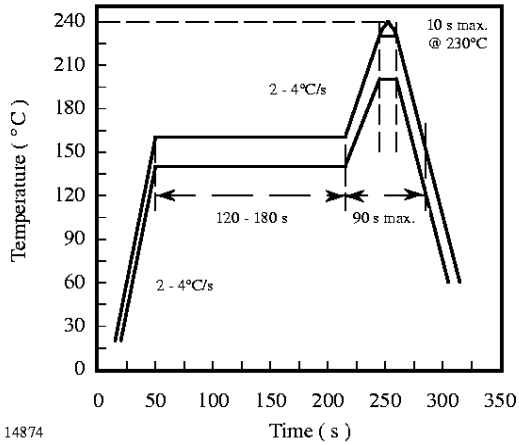

Figure 9. Recommended Solder Profile

Current Derating Diagram

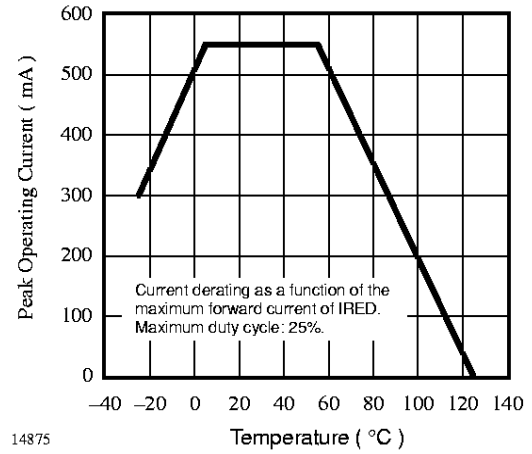
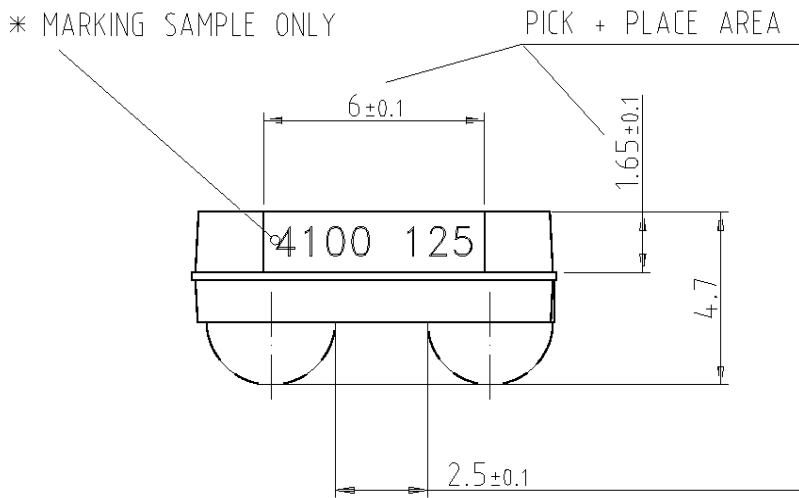
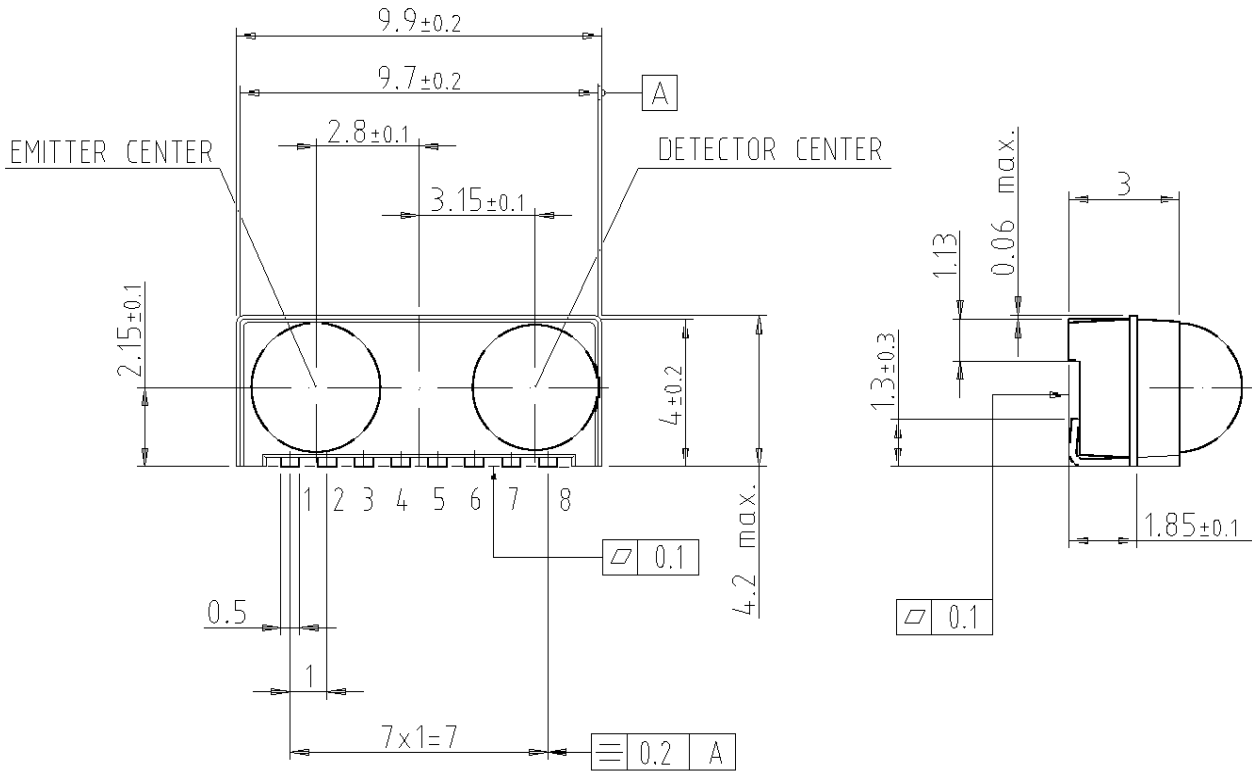

Figure 10. Current Derating Diagram

TFDU6100E – Baby Face (Universal) Package (Mechanical Dimensions)



* MARKING ORIENTATION
180 DEGREES ALLOWED

Drawing-No.: 6.550-5148.01-4
Issue: 8; 10.7.98

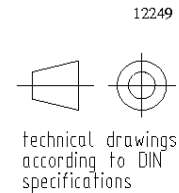



TFDS6500E – Side View Package (Mechanical Dimensions)

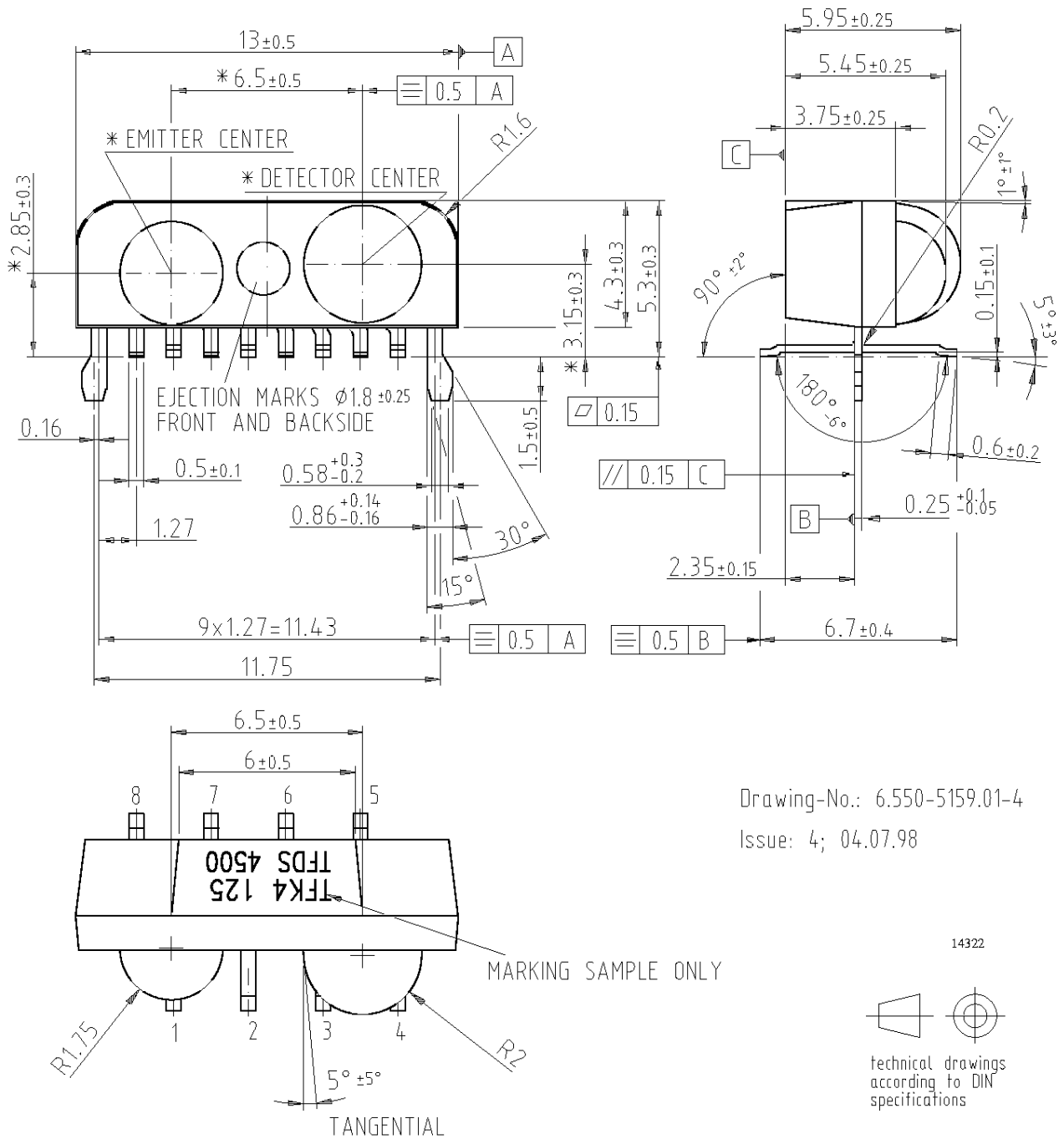

Drawing-No.: 6.550-5159.01-4
Issue: 4; 04.07.98

14322

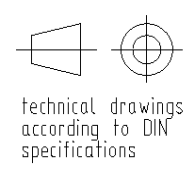

TFDT6500E – Top View Package (Mechanical Dimensions)

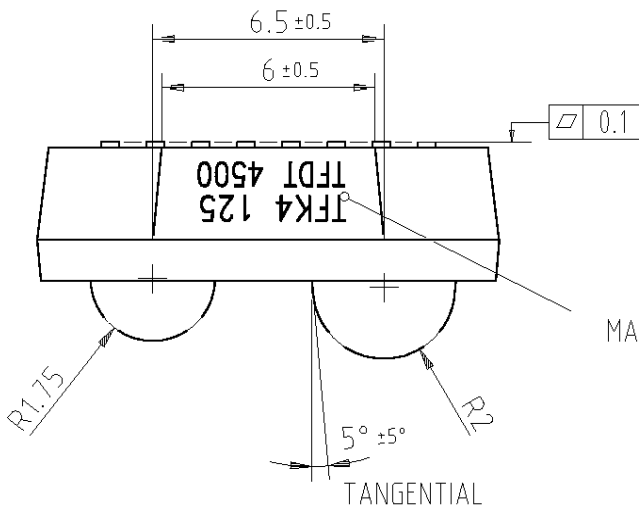
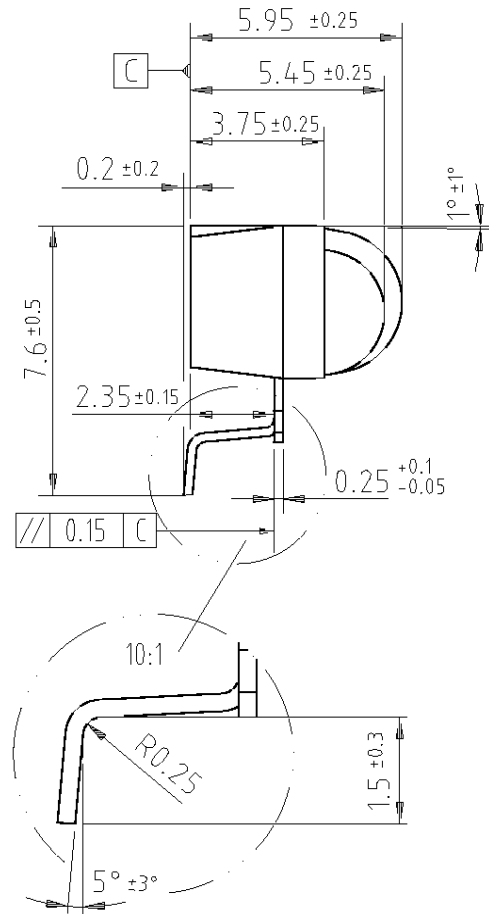
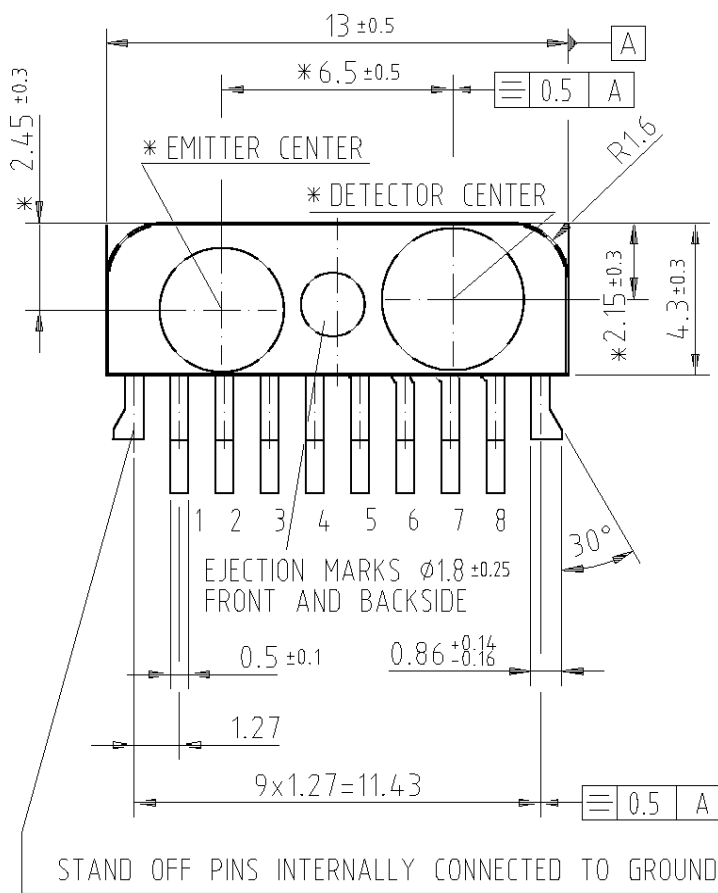

Drawing-No.: 6.550-5160.01-4
Issue: 4; 28.07.98

MARKING SAMPLE ONLY

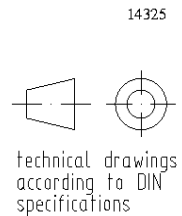



Ozone Depleting Substances Policy Statement

It is the policy of **Vishay Semiconductor GmbH** to

1. Meet all present and future national and international statutory requirements.
2. Regularly and continuously improve the performance of our products, processes, distribution and operating systems with respect to their impact on the health and safety of our employees and the public, as well as their impact on the environment.

It is particular concern to control or eliminate releases of those substances into the atmosphere which are known as ozone depleting substances (ODSs).

The Montreal Protocol (1987) and its London Amendments (1990) intend to severely restrict the use of ODSs and forbid their use within the next ten years. Various national and international initiatives are pressing for an earlier ban on these substances.

Vishay Semiconductor GmbH has been able to use its policy of continuous improvements to eliminate the use of ODSs listed in the following documents.

1. Annex A, B and list of transitional substances of the Montreal Protocol and the London Amendments respectively
2. Class I and II ozone depleting substances in the Clean Air Act Amendments of 1990 by the Environmental Protection Agency (EPA) in the USA
3. Council Decision 88/540/EEC and 91/690/EEC Annex A, B and C (transitional substances) respectively.

Vishay Semiconductor GmbH can certify that our semiconductors are not manufactured with ozone depleting substances and do not contain such substances.

We reserve the right to make changes to improve technical design and may do so without further notice.

Parameters can vary in different applications. All operating parameters must be validated for each customer application by the customer. Should the buyer use Vishay Telefunken products for any unintended or unauthorized application, the buyer shall indemnify Vishay Telefunken against all claims, costs, damages, and expenses, arising out of, directly or indirectly, any claim of personal damage, injury or death associated with such unintended or unauthorized use.

Vishay Semiconductor GmbH, P.O.B. 3535, D-74025 Heilbronn, Germany
Telephone: 49 (0) 7131 67 2831, Fax number: 49 (0) 7131 67 2423