

LOC	DIST	REVISIONS					
DW		P	LTR	DESCRIPTION	DATE	DWN	APVD
		C		REVISED (ECR-09-002723)	06FEB09	BH	WK

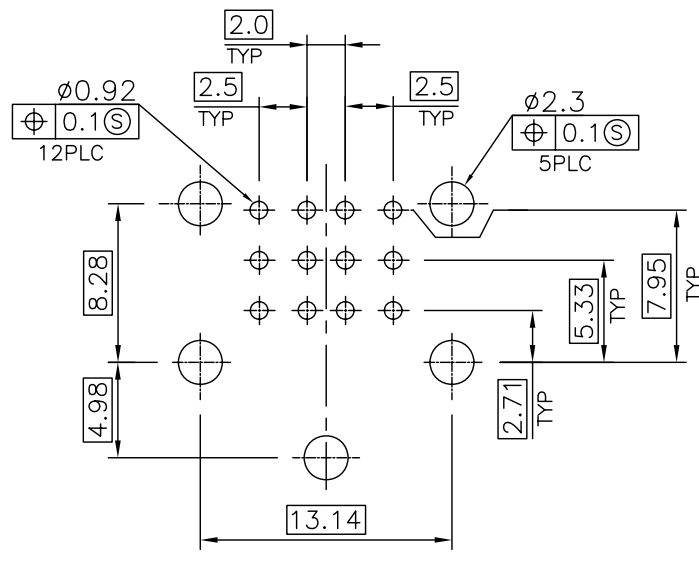

RECOMMENDED PCB LAYOUT  
 TOLERANCE: ±0.05mm

- NOTES:
- MATERIAL:  
 HOUSING: A. PA6T WITH 30% GF, UL 94V-0, COLOR: SEE TABLE.  
 B. PA9T WITH 33% GF, UL 94V-0, COLOR: BLACK.  
 CONTACTS: PHOSPHOR BRONZE.  
 SHELL: PHOSPHOR BRONZE.  
 SPRING: STAINLESS.  
 REAR SHELL: PHOSPHOR BRONZE.
  - FINISH:  
 CONTACTS: GOLD PLATING (SEE TABLE) IN CONTACT AREA, 2.54um[100u"] MIN. MATTE TIN PLATING ON SOLDER TAILS, 1.27um[50u"] MIN. NICKEL UNDERPLATED OVER ALL.  
 SHELL: A. 2.54um[100u"] MIN. BRIGHT TIN PLATING OVER 1.27um[50u"] MIN. NICKEL UNDERPLATED. OR  
 B. 2.54um[100u"] MIN. BRIGHT TIN PLATING OVER 2.03um[80u"] MIN. NICKEL UNDERPLATED.  
 SPRING: 1.27um[50u"] MIN. NICKEL PLATING.  
 REAR SHELL: 1.27um[50u"] MIN. NICKEL PLATING.
  - RECOMMENDED PCB THICKNESS: 1.6mm.
  - WAVE SOLDER CAPABLE TO 265° PER TE SPEC. 109-202, CONDITION B.
  - RELOW SOLDER CAPABLE TO 260° PER TE SPEC. 109-201, CONDITION B.
  - "●" APPLIED FOR 1-1734309-5 ONLY

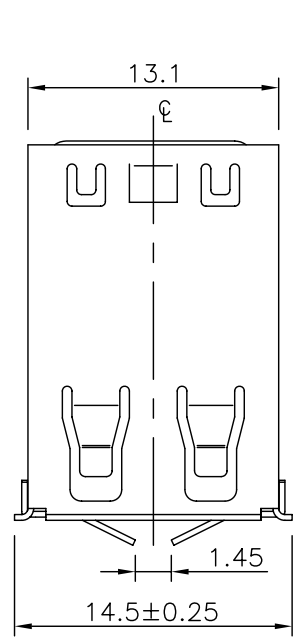
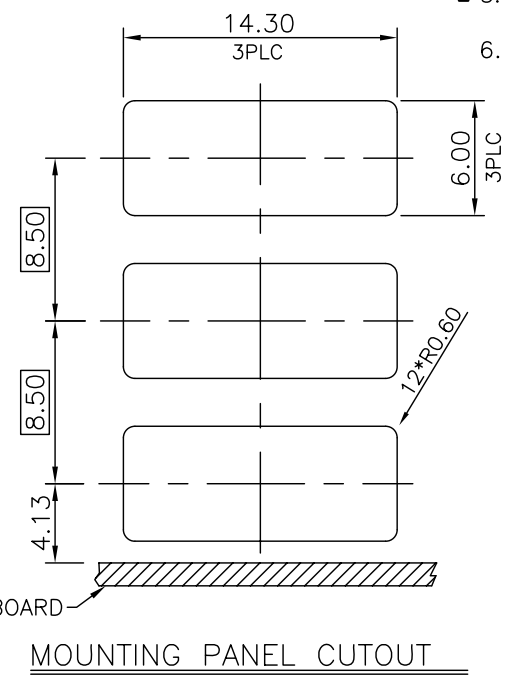
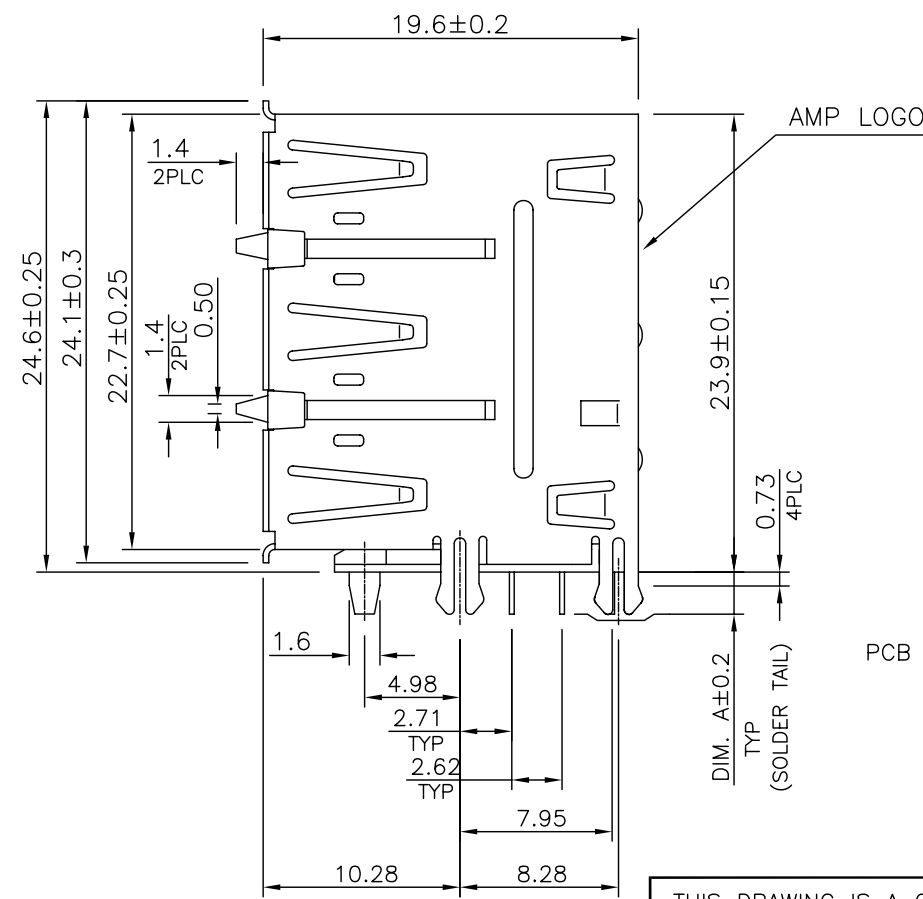
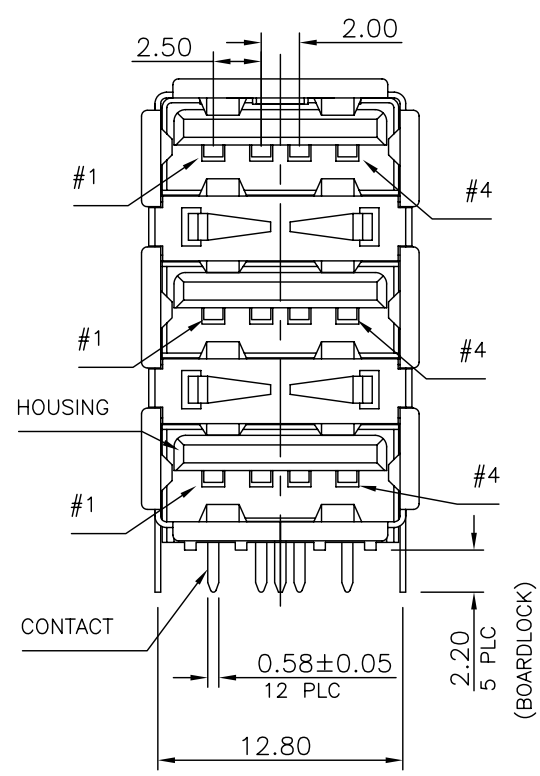

2.84	BEIGE (726C)	15u"	2-1734309-8
	BLACK (426C)	15u"	2-1734309-7
	BEIGE (726C)	30u"	2-1734309-6
	BLACK (426C)	30u"	2-1734309-5
	BEIGE (726C)	5u"	2-1734309-4
	BLACK (426C)	5u"	2-1734309-3
	BEIGE (726C)	G/F	2-1734309-2
	BLACK (426C)	G/F	2-1734309-1
2.2	BEIGE (726C)	15u"	1734309-8
	BLACK (426C)	15u"	1734309-7
	BEIGE (726C)	30u"	1734309-6
	BLACK (426C)	30u"	1734309-5
	BEIGE (726C)	5u"	1734309-4
	BLACK (426C)	5u"	1734309-3
	BEIGE (726C)	G/F	1734309-2
	BLACK (426C)	G/F	1734309-1
DIM A	HOUSING COLOR	MIN. GOLD THICKNESS	PART NUMBER

WITH SPRING

THIS DRAWING IS A CONTROLLED DOCUMENT.

DWN	B. HSING	06FEB2009	Tyco Electronics Corporation Taipei, Taiwan
CHK	S. CHIEN	06FEB2009	
APVD	W. KODAMA	06FEB2009	
PRODUCT SPEC	108-57519		
QUALIFICATION TEST REPORT	501-57592		NAME
WEIGHT	9.2 GRAMS		SIZE
CUSTOMER DRAWING			CAGE CODE
			DRAWING NO
			RESTRICTED TO
			SCALE
			SHEET
			1 OF 3
			REV
			C

THIS DRAWING IS UNPUBLISHED. RELEASED FOR PUBLICATION  
 © COPYRIGHT BY TYCO ELECTRONICS CORPORATION. ALL RIGHTS RESERVED.

LOC		DIST		REVISIONS					
DW				P	LTR	DESCRIPTION	DATE	DWN	APVD
				SEE SHEET 1.					

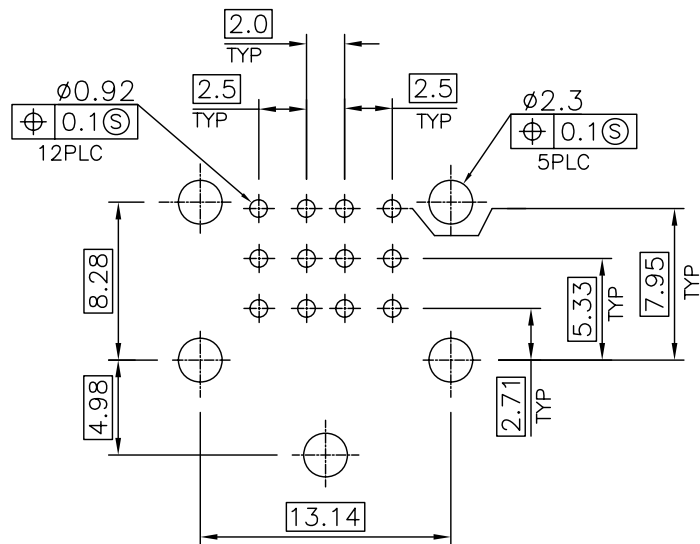
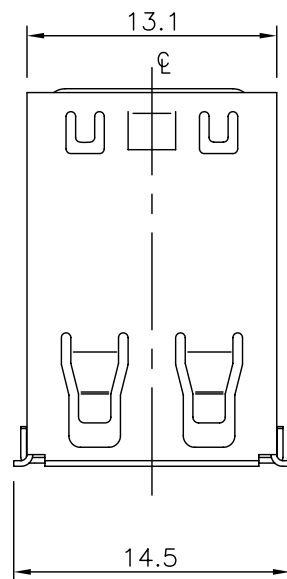

RECOMMENDED PCB LAYOUT  
 TOLERANCE: ±0.05mm

WITHOUT SPRING

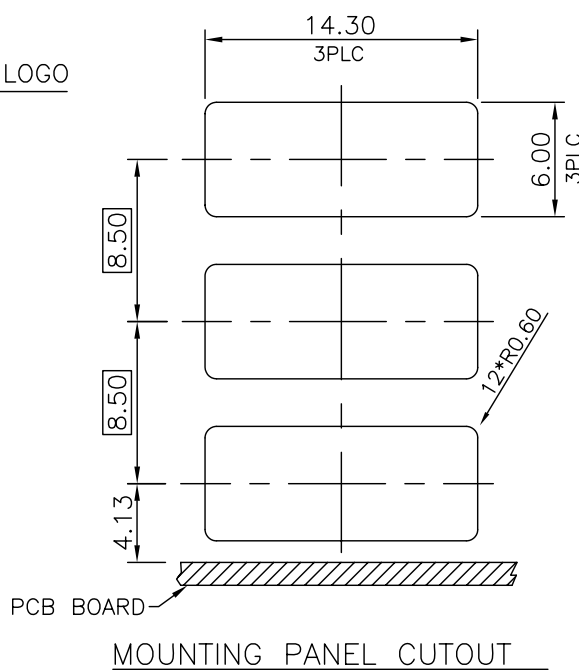
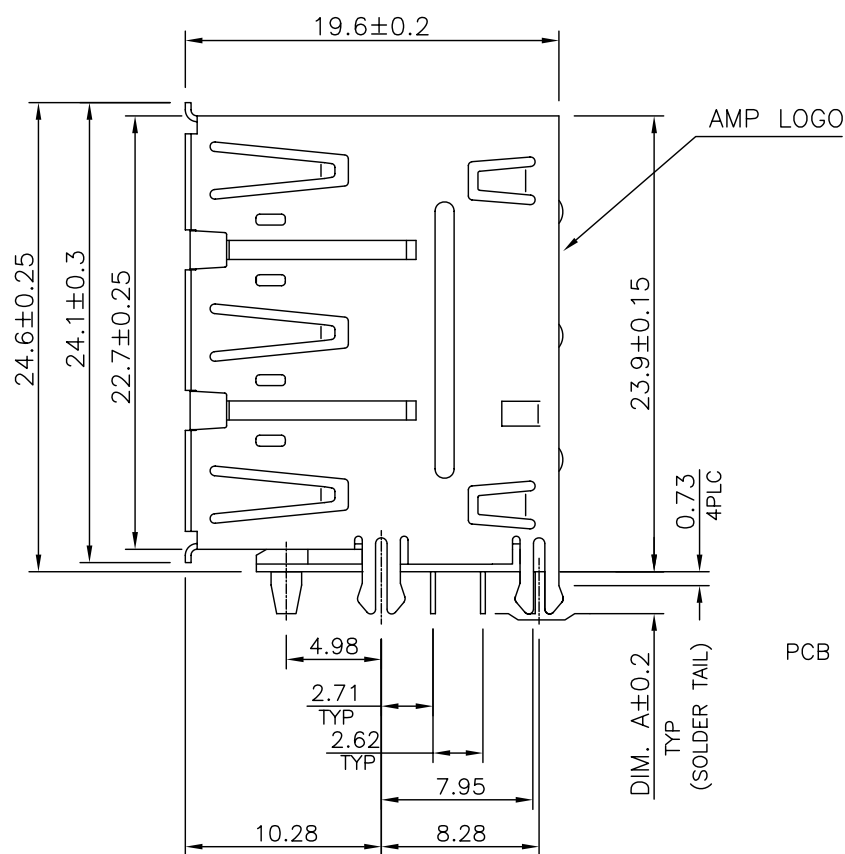
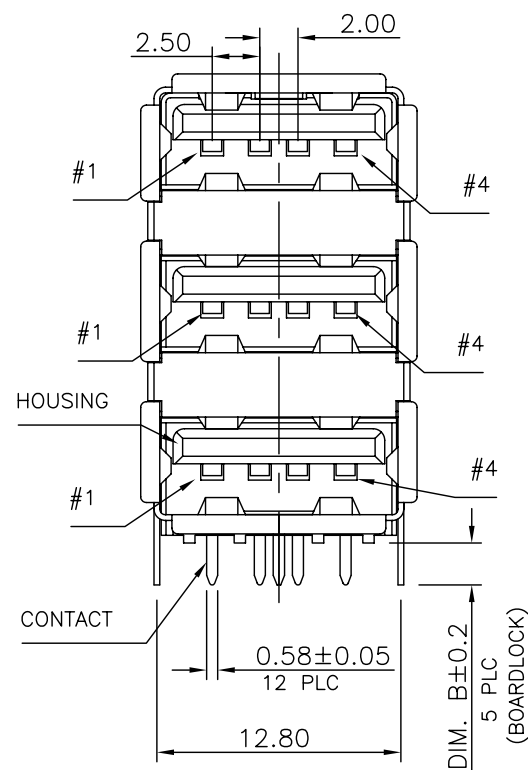

2.84	2.84	BLACK (426C)	15u"	5-1734309-7		
2.2	2.84	BEIGE (726C)	15u"	3-1734309-8		
		BLACK (426C)	15u"	3-1734309-7		
		BEIGE (726C)	30u"	3-1734309-6		
		BLACK (426C)	30u"	3-1734309-5		
		BEIGE (726C)	5u"	3-1734309-4		
		BLACK (426C)	5u"	3-1734309-3		
		BEIGE (726C)	G/F	3-1734309-2		
		BLACK (426C)	G/F	3-1734309-1		
		2.2	2.2	BEIGE (726C)	15u"	1-1734309-8
				BLACK (426C)	15u"	1-1734309-7
BEIGE (726C)	30u"			1-1734309-6		
BLACK (426C)	30u"			1-1734309-5		
BEIGE (726C)	5u"			1-1734309-4		
BLACK (426C)	5u"			1-1734309-3		
		BEIGE (726C)	G/F	1-1734309-2		
		BLACK (426C)	G/F	1-1734309-1		
DIM B	DIM A	HOUSHING COLOR	MIN. GOLD THICKNESS	PART NUMBER		

THIS DRAWING IS A CONTROLLED DOCUMENT.		DWN		Tyco Electronics Corporation Taipi, Taiwan	
DIMENSIONS: MM		CHK		NAME	
TOLERANCES UNLESS OTHERWISE SPECIFIED:		APVD		TRIPLE STACKED USB, A TYPE, RECEPTACLE, R/A, DIP CONN.	
0 PLC ± -		PRODUCT SPEC		SIZE	
1 PLC ± 0.30		108-57519		CAGE CODE	
2 PLC ± 0.25		APPLICATION SPEC		DRAWING NO	
3 PLC ± 0.20		501-57592		RESTRICTED TO	
4 PLC ± -		WEIGHT 9.0 GRAMS		A3 00779 C=1734309	
ANGLES ± 3'		CUSTOMER DRAWING		SCALE	
MATERIAL		FINISH		SHEET 2 OF 3	
				REV C	

4

3

2

1

THIS DRAWING IS UNPUBLISHED.

RELEASED FOR PUBLICATION

© COPYRIGHT BY TYCO ELECTRONICS CORPORATION. ALL RIGHTS RESERVED.

LOC

DIST

REVISIONS

DW

P

LTR

DESCRIPTION

DATE

DWN

APVD

SEE SHEET 1.

100PCS/TRAY

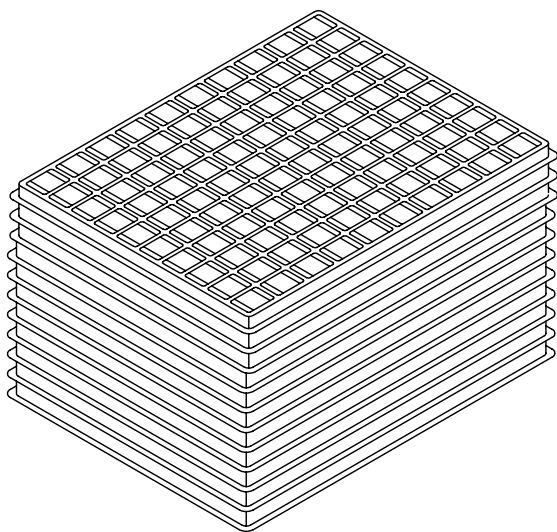
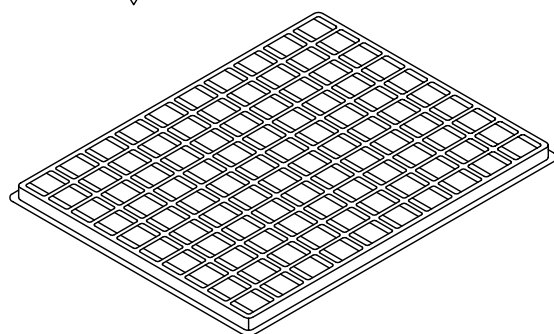
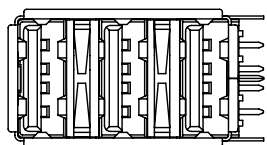

10 LAYERS

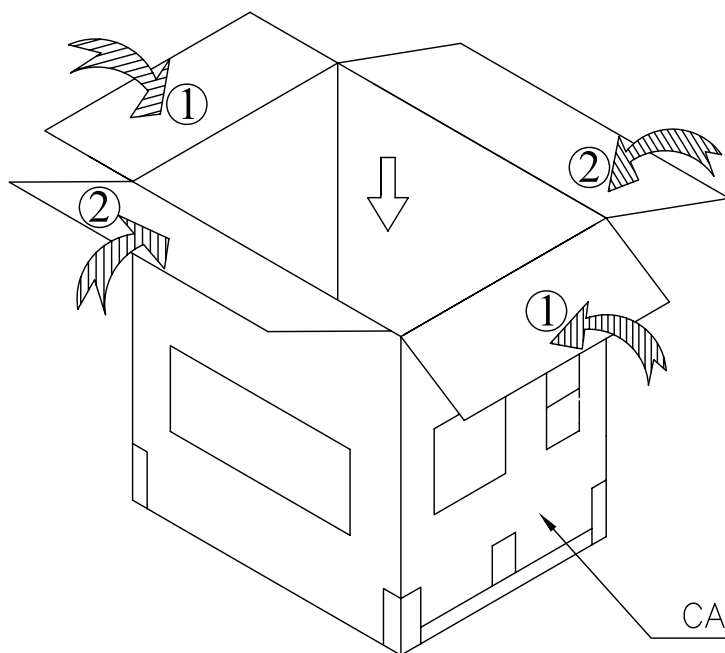

CARTON

TAPE

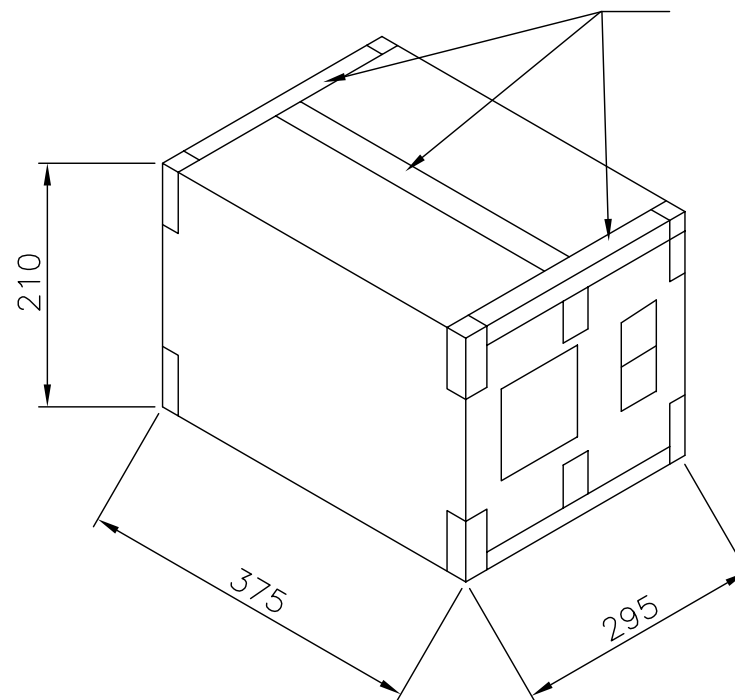

13.0	12.0	100	10	1000
G/W (KG)	N/W (KG)	PCS/TRAY	TRAY/CARTON	PCS/CARTON

THIS DRAWING IS A CONTROLLED DOCUMENT.

DIMENSIONS: MM

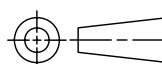

MATERIAL

TOLERANCES UNLESS OTHERWISE SPECIFIED:

0 PLC	± -
1 PLC	± -
2 PLC	± -
3 PLC	± -
4 PLC	± -
ANGLES	± -

FINISH

DWN

CHK

APVD

PRODUCT SPEC

APPLICATION SPEC

WEIGHT

CUSTOMER DRAWING



Tyco Electronics Corporation  
Taipei, Taiwan

NAME

TRIPLE STACKED USB, A TYPE, RECEPTACLE, R/A, DIP CONN.

SIZE

CAGE CODE

DRAWING NO

RESTRICTED TO

A3

00779

C=1734309

SCALE

SHEET

3 OF 3

REV C