

M SERIES | OUTPUT MODULES

I/O MODULES

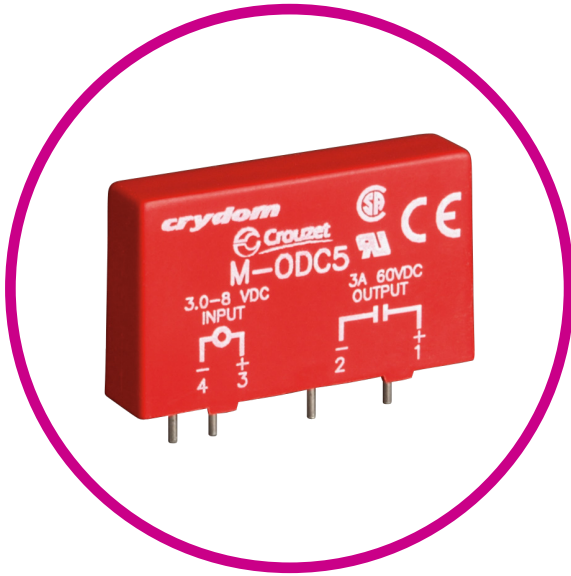

Features

- AC Modules have High Current Thyristors with 100 Amp
- Surge Capability
- Plug into mounting boards for 0.6" modules
- Zero or Random Turn-On Available in AC Modules
- 4kV Optical isolation (1500 VAC Isolation for FET DC Output Modules)
- UL Recognized, CSA Certified, CE Compliant
- Industry standard packaging and Color Coding Black (AC Output) Red (DC Output)

SPECIFICATIONS

Input

Part Number	M-OAC5	M-OAC5A	M-OAC5AH	M-OAC5AR	M-OAC5R
Nominal Voltage [VDC]	5.0	5.0	5.0	5.0	5.0
Minimum Voltage [VDC] ⁽²⁾	2.75	2.75	2.75	2.75	2.75
Maximum Voltage [VDC]	8.0	8.0	8.0	8.0	8.0
Drop-out Voltage [VDC]	1.0	1.0	1.0	1.0	1.0
Maximum Current [mA] ⁽³⁾	20	20	20	20	20
Resistance [Ohms] ⁽⁴⁾	220	220	220	220	220

Part Number	M-OAC24	M-OAC24A	M-ODC5	M-ODC5A	M-ODC5F
Nominal Voltage [VDC]	24	24	5.0	5.0	5.0
Minimum Voltage [VDC] ⁽²⁾	18	18	2.75	2.75	2.75
Maximum Voltage [VDC]	32	32	8.0	8.0	8.0
Drop-out Voltage [VDC]	1.0	1.0	1.0	1.0	1.0
Maximum Current [mA] ⁽³⁾	13	13	18	18	18
Resistance [Ohms] ⁽⁴⁾	2000	2000	250	250	250

Part Number	M-ODC5MA	M-ODC5MC	M-ODC5ML	M-ODC24	M-ODC24A
Nominal Voltage [VDC]	5.0	5.0	5.0	24	24
Minimum Voltage [VDC]⁽²⁾	2.75	2.75	2.75	18	18
Maximum Voltage [VDC]	8.0	8.0	8.0	32	32
Drop-out Voltage [VDC]	1.0	1.0	1.0	1.0	1.0
Maximum Current [mA]⁽³⁾	18	18	18	13	13
Resistance [Ohms]⁽⁴⁾	250	250	250	2000	2000

Output

Part Number	M-OAC5	M-OAC5A	M-OAC5AH	M-OAC5AR	M-OAC5R
Nominal Line Voltage	120 VAC	240 VAC	240 VAC	240 VAC	120 VAC
Minimum Line Voltage	12 VAC	24 VAC	24 VAC	24 VAC	12 VAC
Maximum Line Voltage	140 VAC	280 VAC	280 VAC	280 VAC	140 VAC
Max Off-State Voltage⁽⁵⁾	400 Vpeak	600 Vpeak	600 Vpeak	600 Vpeak	400 Vpeak
Max Off-State Leakage⁽⁶⁾	0.1mArms	0.1mArms	0.1mArms	0.1mArms	0.1mArms
Static Off-State dv/dt⁽⁷⁾	200 V/usec	200 V/usec	200 V/usec	200 V/usec	200 V/usec
Maximum Rated On-State Current⁽⁸⁾	3.5 Arms	3.5 Arms	5.0 Arms	3.5 Arms	3.5 Arms
Minimum On-State Current	50 mArms	50 mArms	50 mArms	50 mArms	50 mArms
Max Surge Current⁽⁹⁾	100 Apeak	100 Apeak	100 Apeak	100 Apeak	100 Apeak
On-State Voltage Drop or Resistance⁽¹⁰⁾	1.6 V	1.6 V	1.6 V	1.6 V	1.6 V
Maximum Turn-On Time [msec] (13)	8.33	8.33	8.33	0.1	0.1
Maximum Turn-Off Time [msec] (13)	8.33	8.33	8.33	8.33	8.33
Input/Output Isolation Voltage (14)	4000 Vrms	4000 Vrms	4000 Vrms	4000 Vrms	4000 Vrms
Input/Output Capacitance	8 pF	8 pF	8 pF	8 pF	8 pF
Operating Temperature Range	-30 to 80°C	-30 to 80°C	-30 to 80°C	-30 to 80°C	-30 to 80°C
Storage Temperature Range	-40 to 80°C	-40 to 80°C	-40 to 80°C	-40 to 80°C	-40 to 80°C
Line Frequency Range	47 to 63 Hz	47 to 63 Hz	47 to 63 Hz	47 to 63 Hz	47 to 63 Hz
Weight	1.1 oz. (31.2g)	1.1 oz. (31.2g)	1.1 oz. (31.2g)	1.1 oz. (31.2g)	1.1 oz. (31.2g)

Part Number	M-OAC24	M-OAC24A	M-ODC5	M-ODC5A	M-ODC5F
Nominal Line Voltage	120 VAC	240 VAC	5-48 VDC	5-150 VDC	5-48 VDC
Minimum Line Voltage	12 VAC	24 VAC	3.0 VDC	3.0 VDC	3.0 VDC
Maximum Line Voltage	140 VAC	280 VAC	60 VDC	250 VDC	60 VDC
Max Off-State Voltage ⁽⁵⁾	400 Vpeak	600 Vpeak	60 VDC	250 VDC	60 VDC
Max Off-State Leakage ⁽⁶⁾	0.1mArms	0.1mArms	10 uA	10 uA	1mA
Static Off-State dv/dt ⁽⁷⁾	200 V/usec	200 V/usec	N/A	N/A	N/A
Maximum Rated On-State Current ⁽⁸⁾	3.5 Arms	3.5 Arms	3.0 A	1.0 A	3.0 A
Minimum On-State Current	50 mArms	50 mArms	10 mA	10 mA	10 mA
Max Surge Current ⁽⁹⁾	100 Apeak	100 Apeak	5.0 A	5.0 A	5.0 A
On-State Voltage Drop or Resistance ⁽¹⁰⁾	1.6 V	1.6 V	1.5 V	1.5 V	1.5 V
Maximum Turn-On Time [msec] ⁽¹³⁾	8.33	8.33	0.1	0.1	0.025
Maximum Turn-Off Time [msec] ⁽¹³⁾	8.33	8.33	0.75	0.75	0.05
Input/Output Isolation Voltage ⁽¹⁴⁾	4000 Vrms	4000 Vrms	4000 Vrms	4000 Vrms	4000 Vrms
Input/Output Capacitance	8 pF	8 pF	8 pF	8 pF	8 pF
Operating Temperature Range	-30 to 80°C	-30 to 80°C	-30 to 80°C	-30 to 80°C	-30 to 80°C
Storage Temperature Range	-40 to 80°C	-40 to 80°C	-40 to 80°C	-40 to 80°C	-40 to 80°C
Line Frequency Range	47 to 63 Hz	47 to 63 Hz	DC	DC	DC
Weight	1.1 oz. (31.2g)	1.1 oz. (31.2g)	1.1 oz. (31.2g)	1.1 oz. (31.2g)	1.1 oz. (31.2g)

Part Number	M-ODC5MA	M-ODC5MC	M-ODC5ML	M-ODC24	M-ODC24A
Nominal Line Voltage	5-150 VDC	5-90 VDC	5-48 VDC	5-48 VDC	5-150 VDC
Minimum Line Voltage	1.0 VDC	1.0 VDC	50 VDC	60 VDC	250 VDC
Maximum Line Voltage	200 VDC	100 VDC	50 VDC	60 VDC	250 VDC
Max Off-State Voltage ⁽⁵⁾	200 VDC	100 VDC	50 VDC	60 VDC	250 VDC
Max Off-State Leakage ⁽⁶⁾	10 uA	10 uA	10 uA	10 uA	10 uA
Static Off-State dv/dt ⁽⁷⁾	N/A	N/A	N/A	N/A	N/A
Maximum Rated On-State Current ⁽⁸⁾	3.0 A	5.0 A	1.0 A	3.0 A	
Minimum On-State Current	1.0 mA	1.0 mA	10 mA	10 mA	10 mA
Max Surge Current ⁽⁹⁾	10 A	10 A	10 A	5.0 A	5.0 A
On-State Voltage Drop or Resistance ⁽¹⁰⁾	0.25 Ohms	0.10 Ohms	0.05 Ohms	1.5 V	1.5 V
Maximum Turn-On Time [msec] ⁽¹³⁾	1.0	1.0	1.0	0.1	0.1
Maximum Turn-Off Time [msec] ⁽¹³⁾	0.05	0.05	0.05	0.75	0.75
Input/Output Isolation Voltage ⁽¹⁴⁾	1500 Vrms	1500 Vrms	1500 Vrms	4000 Vrms	4000 Vrms
Input/Output Capacitance	8 pF	8 pF	8 pF	8 pF	8 pF
Operating Temperature Range	-30 to 80°C	-30 to 80°C	-30 to 80°C	-30 to 80°C	-30 to 80°C
Storage Temperature Range	-40 to 80°C	-40 to 80°C	-40 to 80°C	-40 to 80°C	-40 to 80°C
Line Frequency Range	DC	DC	DC	DC	DC
Weight	1.1 oz. (31.2g)	1.1 oz. (31.2g)	1.1 oz. (31.2g)	1.1 oz. (31.2g)	1.1 oz. (31.2g)

GENERAL NOTES

- (1) Specifications apply to an ambient temperature of -30 to 80 °C unless otherwise noted.
- (2) Without external LED status indicator Add 1.7 volts for external LED if utilized.
- (3) At nominal input voltage, without external LED status indicator.
- (4) +/- 10% at 25°C.
- (5) Maximum 1 minute duration for OAC modules when applied as a DC voltage rather than a peak AC voltage.
- (6) At maximum line voltage, 25°C for OAC modules, and 80°C for ODC modules.
- (7) Minimum DV/DT per EIA/NARM RS433, method RS397, DV/DT ratings do not apply to DC output models.
- (8) At 40°C derate OAC modules 58 mA/°C to 80°C derate ODC, ODCxMC and ODCxML modules 50mA/°C to 80°C CSA rating of OAC modules is 3.0 Arms at 40°C
- (9) At 25°C for 1 second maximum duration: 1 AC cycle for AC modules, 1 second for DC modules.
- (10) At maximum rated on-state current and 25°C.
- (11) At maximum line voltage, maximum rated output current, nominal input voltage and 25°C switching speed of OAC modules is based upon 60 Hz line frequency
- (12) At 25°C for 1 second maximum duration.
- (13) 1/3 HP at 240 VAC 1/8 HP at 120 VAC.
- (14) At 25°C for 1 second maximum duration.

EQUIVALENT CIRCUIT DIAGRAMS / MECHANICAL SPECIFICATIONS

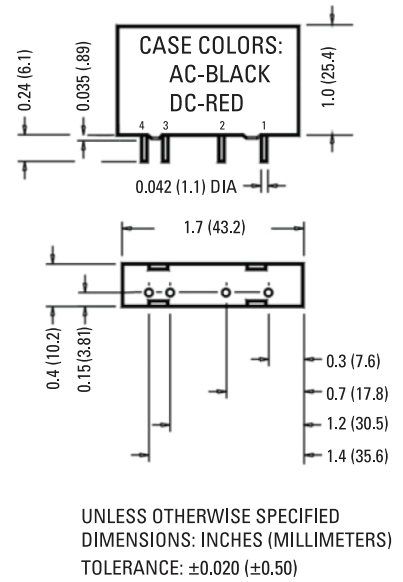
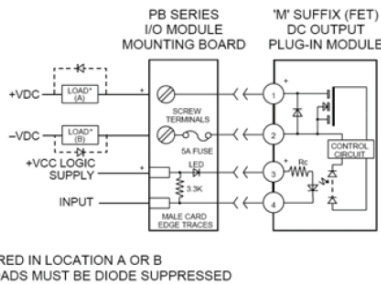
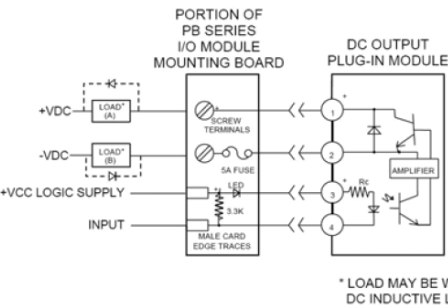
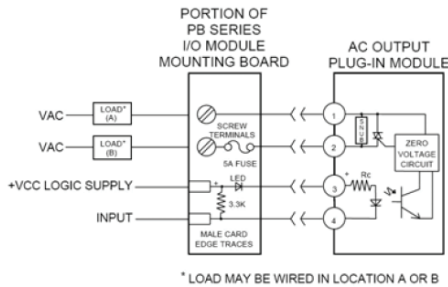

AGENCY APPROVALS & CERTIFICATIONS





WARNINGS



RISK OF MATERIAL DAMAGE AND HOT ENCLOSURE

- The product's side panels may be hot, allow the product to cool before touching
- Follow proper mounting instructions including torque values
- Do not allow liquids or foreign objects to enter this product

Failure to follow these instructions can result in serious injury, or equipment damage.



HAZARD OF ELECTRIC SHOCK, EXPLOSION OR ARC FLASH

- Disconnect all power before installing or working with this equipment
- Verify all connections and replace all covers before turning on power

Failure to follow these instructions will result in death or serious injury.

Sensata Technologies, Inc. ("Sensata") data sheets are solely intended to assist designers ("Buyers") who are developing systems that incorporate Sensata products (also referred to herein as "components"). Buyer understands and agrees that Buyer remains responsible for using its independent analysis, evaluation and judgment in designing Buyer's systems and products. Sensata data sheets have been created using standard laboratory conditions and engineering practices. Sensata has not conducted any testing other than that specifically described in the published documentation for a particular data sheet. Sensata may make corrections, enhancements, improvements and other changes to its data sheets or components without notice.

Buyers are authorized to use Sensata data sheets with the Sensata component(s) identified in each particular data sheet. HOWEVER, NO OTHER LICENSE, EXPRESS OR IMPLIED, BY ESTOPPEL OR OTHERWISE TO ANY OTHER SENSATA INTELLECTUAL PROPERTY RIGHT, AND NO LICENSE TO ANY THIRD PARTY TECHNOLOGY OR INTELLECTUAL PROPERTY RIGHT, IS GRANTED HEREIN. SENSATA DATA SHEETS ARE PROVIDED "AS IS". SENSATA MAKES NO WARRANTIES OR REPRESENTATIONS WITH REGARD TO THE DATA SHEETS OR USE OF THE DATA SHEETS, EXPRESS, IMPLIED OR STATUTORY, INCLUDING ACCURACY OR COMPLETENESS. SENSATA DISCLAIMS ANY WARRANTY OF TITLE AND ANY IMPLIED WARRANTIES OF MERCHANTABILITY, FITNESS FOR A PARTICULAR PURPOSE, QUIET ENJOYMENT, QUIET POSSESSION, AND NON-INFRINGEMENT OF ANY THIRD PARTY INTELLECTUAL PROPERTY RIGHTS WITH REGARD TO SENSATA DATA SHEETS OR USE THEREOF.

All products are sold subject to Sensata's terms and conditions of sale supplied at www.sensata.com SENSATA ASSUMES NO LIABILITY FOR APPLICATIONS ASSISTANCE OR THE DESIGN OF BUYERS' PRODUCTS. BUYER ACKNOWLEDGES AND AGREES THAT IT IS SOLELY RESPONSIBLE FOR COMPLIANCE WITH ALL LEGAL, REGULATORY AND SAFETY-RELATED REQUIREMENTS CONCERNING ITS PRODUCTS, AND ANY USE OF SENSATA COMPONENTS IN ITS APPLICATIONS, NOTWITHSTANDING ANY APPLICATIONS-RELATED INFORMATION OR SUPPORT THAT MAY BE PROVIDED BY SENSATA.

Mailing Address: Sensata Technologies, Inc., 529 Pleasant Street, Attleboro, MA 02703, USA.

CONTACT US

Americas

+1 (877) 502 5500 – Option 2
sales.crydom@sensata.com

Europe, Middle East & Africa

+44 (1202) 416170
ssr-info.eu@sensata.com

Asia Pacific

sales.isasia@list.sensata.com
 China +86 (21) 2306 1500
 Japan +81 (45) 277 7117
 Korea +82 (31) 601 2004
 India +91 (80) 67920890
 Rest of Asia +886 (2) 27602006
 ext 2808