



W3013 Indirect Quadrature Modulator with Gain Control

Features

- Low-voltage operation: 2.7 V
- High-frequency operation: 2.2 GHz
- High RF output power: -10 dBm
- High-accuracy phase shifter, no trim required
- Low carrier feedthrough: -45 dBc
- Automatic power control (APC) capability
- Low-current sleep mode
- 20-pin TSSOP package

Applications

- North American IS-136
- Japan PDC (RCR STD 27)
- Japan PHS (RCR STD 28)
- GSM 900, 1800, and 1900 MHz
- Narrowband CDMA
- Digital satellite communications

Description

The W3013 is a monolithic integrated circuit that provides indirect, quadrature modulation of an RF carrier by I & Q baseband inputs. The function performed by the W3013 is particularly suited for handheld digital cellular and digital cordless telephones that operate between 800 MHz and 2.2 GHz.

The circuit block diagram is shown below. From a single local-oscillator input (LO1), the phase shifter produces two LO signals with 90° phase separation and equal amplitude. The LO signals are fed to the in-phase (I) and quadrature (Q) double-balanced mixers. The resulting signals are summed and fed into an RF mixer where the frequency can be translated to over 2 GHz. Outputs between the summer and RF mixer are available for external filtering. Finally, the signal is amplified to provide a single-ended output.

The ENB/APC input with a logic low allows the device to be put into a powerdown mode. Above the logic low threshold, the device enters a power control mode that provides a range of desired output power levels.

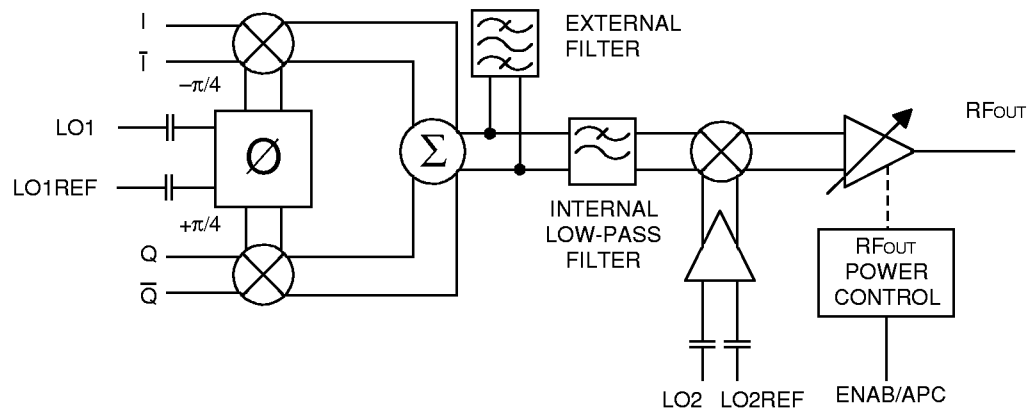

Figure 1. Circuit Block Diagram

Pin Information

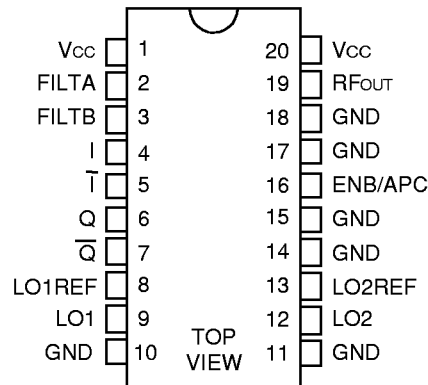

Figure 2. Pin Diagram

12-2680

Table 1. Pin Descriptions

Pin	Symbol	Name/Description
1	Vcc	Positive Supply Voltage. For low-power/small-signal subcircuits.
2, 3	FILTA, FILTB	Filter. Nodes A & B for parallel resonant LC.
4	I	Differential Baseband Input.
5	\bar{I}	Differential Baseband Input (Inverting).
6	Q	Differential Baseband Input.
7	\bar{Q}	Differential Baseband Input (Inverting).
8, 9	LO1REF, LO1	First Local Oscillator Input. Either pin may be directly grounded.
10, 11, 14, 15, 17, 18	GND	Power Supply Ground.
12, 13	LO2, LO2REF	Second Local Oscillator Input. Either pin may be directly grounded.
16	ENB/APC	Enable/Automatic Power Control.
19	RFOUT	RF Output.
20	Vcc	Positive Supply Voltage. For RF output stage.

Absolute Maximum Ratings

Stresses in excess of the absolute maximum ratings can cause permanent damage to the device. These are absolute stress ratings only. Functional operation of the device is not implied at these or any other conditions in excess of those given in the operations sections of the data sheet. Exposure to absolute maximum ratings for extended periods can adversely affect device reliability.

Parameter	Symbol	Min	Max	Unit
Ambient Operating Temperature	T _A	-40	100	°C
Storage Temperature	T _{stg}	-65	150	°C
Lead Temperature (soldering, 10 s)	T _L	—	300	°C
Positive Supply Voltage	V _{CC}	—	5	V _{dc}
Power Dissipation	P _D	—	750	mW
Output Current (continuous)	I _{OUT}	—	160	mA
ac Input Voltage	—	GND	V _{CC}	V _{p-p}
Enable Input Voltage	V _{ENB}	GND	V _{CC}	V _{dc}

Handling Precautions

Although protection circuitry has been designed into this device, proper precautions should be taken to avoid exposure to electrostatic discharge (ESD) during handling and mounting. Lucent Technologies Microelectronics Group employs a human-body model (HBM) and a charged-device model (CDM) for ESD-susceptibility testing and protection design evaluation. ESD voltage thresholds are dependent on the circuit parameters used to define the model. No industry-wide standard has been adopted for CDM. However, a standard HBM (resistance = 1500 Ω, capacitance = 100 pF) is widely used and, therefore, can be used for comparison purposes. The HBM ESD threshold presented here was obtained by using these circuit parameters:

ESD Threshold Voltage		
Device	Rating	Model
W3013	≥1000 V	HBM
W3013	≥1000 V	CDM

Operating Ranges

This table lists the ranges of external conditions in which the W3013 provides general functionality that may be useful in specific applications without risk of permanent damage. However, performance is not guaranteed over the full range of all possible conditions. The conditions for guaranteed performance are described in the Electrical Characteristics table.

Parameter	Min	Typ	Max	Unit
V _{CC}	2.7	—	3.6	V
f _{LO1}	100	178	350	MHz
V _{LO1}	100	250	600	mVp-p
f _{LO2}	100	1620	2200	MHz
V _{LO2}	100	250	600	mVp-p
f _{RF}	<800	—	>2200	MHz
I & Q Input Range of dc Bias for 1 Vp-p Differential Input	V _{CC} /2 – 0.1	V _{CC} /2	V _{CC} /2 + 0.1	Vdc
I & Q Input Range of dc Bias for 1 Vp-p Single-ended Input	V _{CC} /2 – 0.1	V _{CC} /2	V _{CC} /2 + 0.1	Vdc
I (Q) to \bar{I} (\bar{Q}) Differential Input Swing*	—	1.0	1.1	Vp-p
Ambient Operating Temperature	–35	25	85	°C

* Distortion-dependent, e.g., 1.3 Vp-p $\pi/4$ DQPSK peak voltage meets PDC or IS-136 distortion specification under random data modulation.

Electrical Characteristics

Table 2. Electrical Characteristics

Conditions (unless otherwise specified): T_A = 25 °C ± 3 °C, V_{CC} = 2.7 Vdc, R_L = 50 Ω, f_{LO1} = 178 MHz, f_{LO2} = 1620 MHz, P_{LO1} = P_{LO2} = –10 dBm, V_{BIAS(I)} = V_{BIAS(\bar{I})} = V_{BIAS(Q)} = V_{BIAS(\bar{Q})} = V_{CC}/2; I – \bar{I} = 0.5 • cos(2πt • 80 kHz – π/2) V, Q – \bar{Q} = 0.5 • cos(2πt • 80 kHz) V, f_{RFOUT} = 1442.08 MHz, V_{APC} = 2.7 Vdc.

Parameter	Min	Typ	Max	Unit
V_{CC} Supply Current:				
Active Mode	—	37	—	mA
Sleep Mode @ V _{CC} = 3.3 V, ENB/APC ≤ 0.1 Vdc	—	<1	50	μA
I & Q:				
I & Q Signal Path: 3 dB Bandwidth (differential input)	—	21	—	MHz
I & Q Input Bias Current	—	500	1500	nA
I & Q Input Impedance	—	1	—	MΩ
LO1:				
LO1 Suppression (relative to output power)	—	45	—	dBc
LC Filter Pins: Differential Impedance	—	600 1.2	—	Ω pF
LO2:				
LO2 Suppression (relative to output power)	—	35	—	dBc
Modulation Accuracy:				
Carrier Suppression (relative to wanted sideband)	35	50	—	dBc
Lower Sideband Suppression	35	45	—	dBc
Transmitted I and Q Amplitude Error	—	±0.1	—	dB
Transmitted I and Q Phase Error	—	±1	—	degrees
Error Vector Magnitude (See page 6.)	—	1.3	5	%

Electrical Characteristics (continued)

Table 2. Electrical Characteristics (continued)

Conditions (unless otherwise specified): $T_A = 25\text{ }^\circ\text{C} \pm 3\text{ }^\circ\text{C}$, $V_{CC} = 2.7\text{ Vdc}$, $R_L = 50\text{ }\Omega$, $f_{LO1} = 178\text{ MHz}$, $f_{LO2} = 1620\text{ MHz}$, $P_{LO1} = P_{LO2} = -10\text{ dBm}$, $V_{BIAS(I)} = V_{BIAS(\bar{I})} = V_{BIAS(Q)} = V_{BIAS(\bar{Q})} = V_{CC}/2$, $I - \bar{I} = 0.5 \cdot \cos(2\pi t \cdot 80\text{ kHz} - \pi/2)\text{ V}$, $Q - \bar{Q} = 0.5 \cdot \cos(2\pi t \cdot 80\text{ kHz})\text{ V}$, $f_{RFOUT} = 1442.08\text{ MHz}$, $V_{APC} = 2.7\text{ Vdc}$.

Parameter	Min	Typ	Max	Unit
RF Output:				
Output Power (narrowband match):				
1442 MHz	-13	-8	-3	dBm
800 MHz (LO2 = 978 MHz)	—	-8	—	dBm
1910 MHz (LO2 = 1732 MHz)	—	-10	—	dBm
Output Power Total Range of APC Control	—	55	—	dB
Usable APC Range:*				
PDC (IQ offset < -23 dBc, 100 kHz adjacent channel power < -60 dBc)	35	45	—	dBc
IS-136 (IQ offset < -23 dBc, 60 kHz adjacent channel power < -45 dBc)	45	54	—	dBc
Adjacent Channel Suppression at Maximum Output (1.3 Vp-p random data digital modulation):				
0.35-DQPSK Modulation per IS-136:				
±30 kHz	—	-39	-35	dBc
±60 kHz	—	-64	-57	dBc
±90 kHz	—	-67	-57	dBc
0.5-DQPSK Modulation per Japan PDC at Maximum Output:				
±50 kHz	—	-60	-54	dBc
±100 kHz	—	-73	-65	dBc
0.5-DQPSK Modulation per Japan PHS at Maximum Output:				
±600 kHz	—	-62	-50	dBc
±900 kHz	—	-63	-50	dBc
Enable/APC:				
V_{IHMIN} (higher voltage turns device on)	—	0.81	1.0	V
V_{ILMAX} (lower voltage turns device off)	0.6	—	—	V
I_{ILMAX} ($V_{ENABLE/APC} = 0.4\text{ V}$)	—	—	<1	μA
I_{IHMAX} ($V_{ENABLE/APC} = 2.7\text{ V}$)	—	—	40	μA
Powerup/Powerdown Time	—	—	4	μs
APC Voltage for Minimum Output Power	—	1.0	—	Vdc
APC Voltage for Maximum Output Power	2.5	—	—	Vdc
APC Bandwidth	5	—	—	MHz

* Usable APC range is defined to be the satisfaction of respective transmitter system requirements in the adjacent and alternate channels, as well as IQ offset and EVM requirements in each standard.

Error Vector Magnitude (EVM) Testing

Error vector magnitude (EVM) is estimated by feeding signals to the W3013 as described at the top of the Electrical Characteristics table. A narrowband, sine-wave modulation output spectrum is shown in Figure 3.

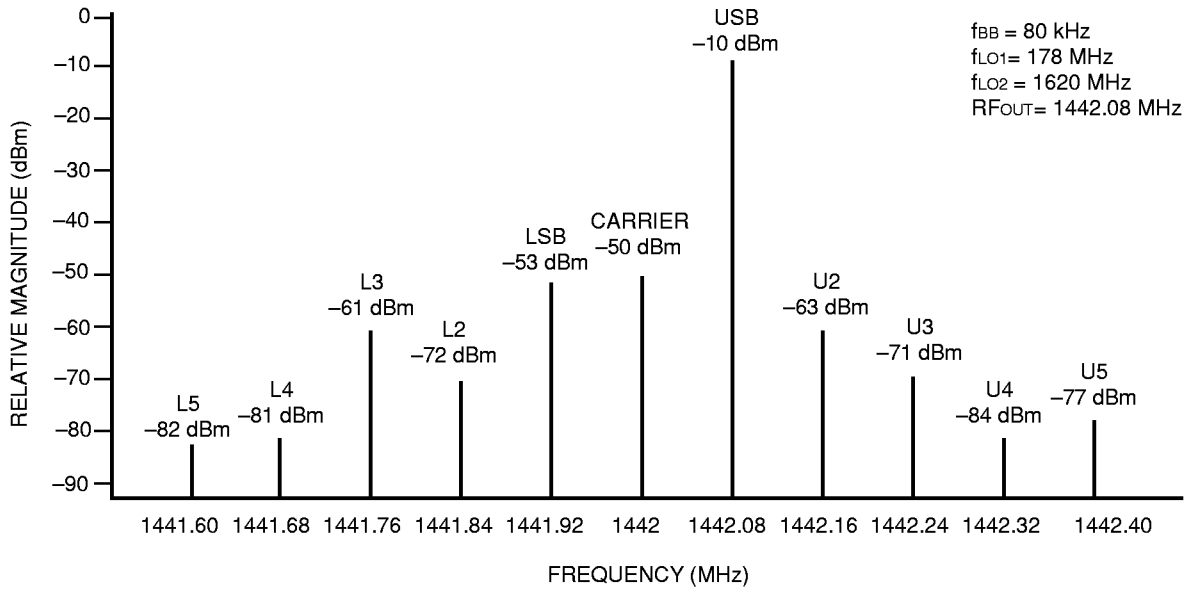

Figure 3. W3013 Sine-Wave Modulation Output Spectrum

Data from this spectrum are used to estimate EVM by the formula:

$$EVM (\%) = 100 \cdot \left[\frac{10^{P(L5)/20}}{10^{P(LSB)/20}} + \frac{10^{P(L4)/20}}{10^{P(U2)/20}} + \frac{10^{P(L3)/20}}{10^{P(U3)/20}} + \frac{10^{P(L2)/20}}{10^{P(U4)/20}} + \frac{10^{P(L1)/20}}{10^{P(U5)/20}} + \frac{10^{P(L1)/20}}{10^{P(USB)/20}} \right]$$

The data presented in the spectrum above would yield:

$$EVM (\%) = 100 \cdot \left[\frac{79e-6 + 89e-6 + 891e-6 + 251e-6 + 2239e-6 + 708e-6 + 282e-6 + 63e-6 + 141e-6}{0.316e} \right]$$

$$= 1.5\%$$

This approximates worst-case digital modulation results because the sine-wave modulation estimate assumes all spurious outputs are in phase and adds their magnitudes as scalars. In addition, this estimate includes full-amplitude measurements of spurious peaks that would appear in adjacent and alternate channels, where a receiver would otherwise provide attenuation. The L3 third-order intermodulation peak and LSB (lower sideband) are normally the unwanted output frequencies that dominate the EVM estimate.

Application Circuits

A typical application circuit for the W3013 is shown in Figure 4. The LC filter components, L_F and C_F , are chosen to have a parallel resonance at the same frequency as LO1, according to the formula

$$f_0 = \frac{1}{2 \sqrt{L_F(C_F + 1.2e-12)}}$$

where f_0 is the center of the filter passband in Hz, L_F is the filter inductor in Henries, and C_F is the filter capacitor in farads. Use of an inductor of 100 nH or larger in the filter will minimize the variation of output power due to tolerance variation of the filter components.

If the transmitter frequency plan requires the use of more than one LO1 frequency, the W3013 RF output power may be approximately equalized by designing the LC filter center frequency at

$$f_0 = \sqrt{f(\text{LO1max})f(\text{LO1min})},$$

i.e., the geometric mean of the maximum and minimum LO1 frequencies.

Board and device parasitic capacitance and inductance must be accounted for in calculating L_F and C_F .

The matching network will vary depending on the application, but must include a series capacitor to block dc connections to the W3013 output pin if the load is conductive. For optimum performance, the bypass capacitor, C_1 , should have a series self-resonant frequency that is close to the output frequency and should be mounted near pin 20. It is expected that the positive supply (V_{CC}) will appear as a low impedance to ground at low frequencies, using a voltage regulator and/or a large capacitor such as a 10 μF tantalum electrolytic.

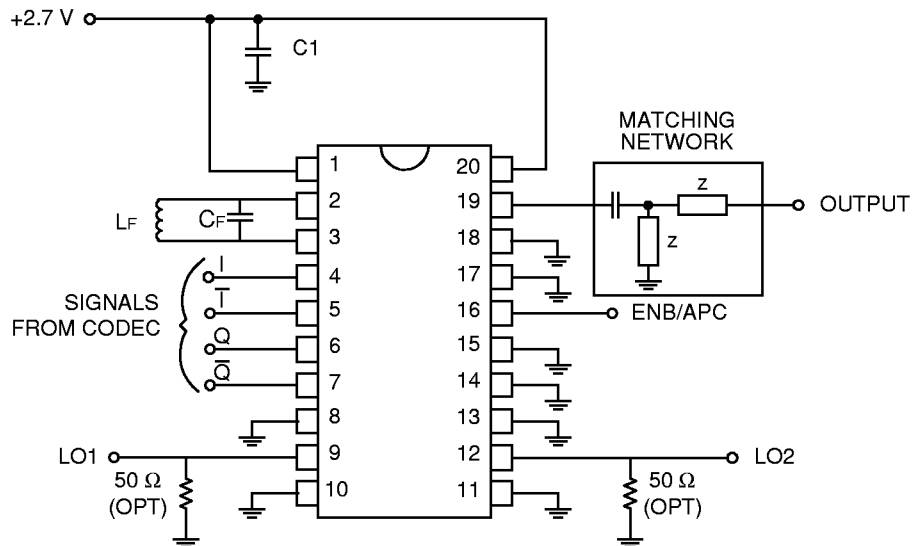

Figure 4. Typical Application Circuit

ENB/APC Function

The ENB/APC lead is used to turn the device on and to control the output power. If the voltage on this lead is below V_{ILMAX} , the device is in a low-current mode. Between V_{IHMIN} and about V_{CC} , the device draws full supply current and is in a power-control mode. In this region, the output power will vary with the voltage on the ENB/APC lead as shown in Figure 5.

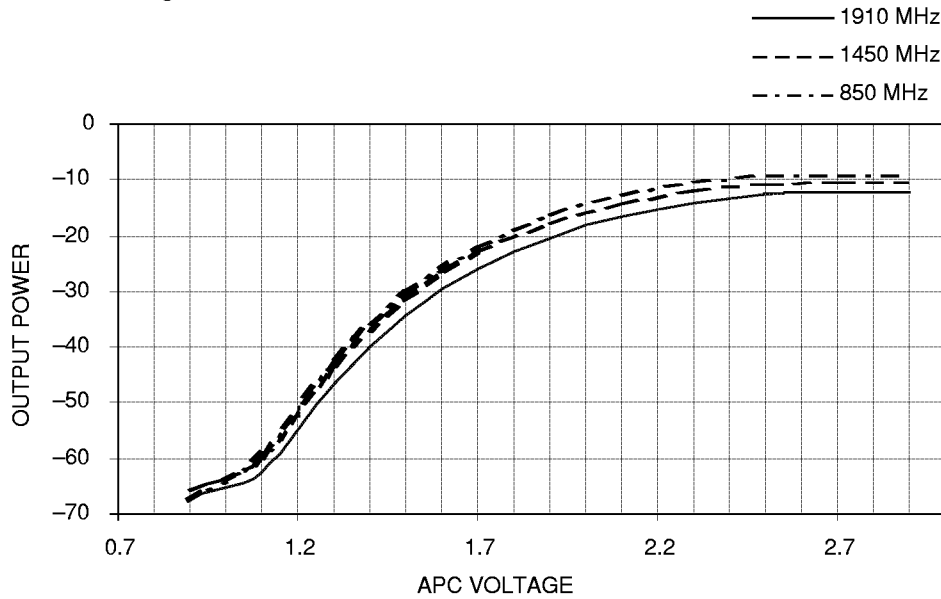

Figure 5. Relative RF Output Power vs. APC Voltage

Characteristic Curves

Unless otherwise specified, the test conditions are identical to those listed for Table 2.

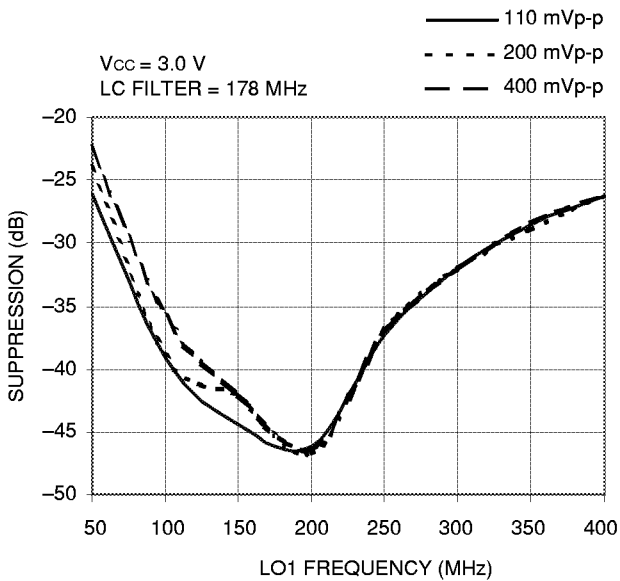

Figure 6. Unwanted Sideband Suppression vs. LO1 Frequency and LO1 Input Level

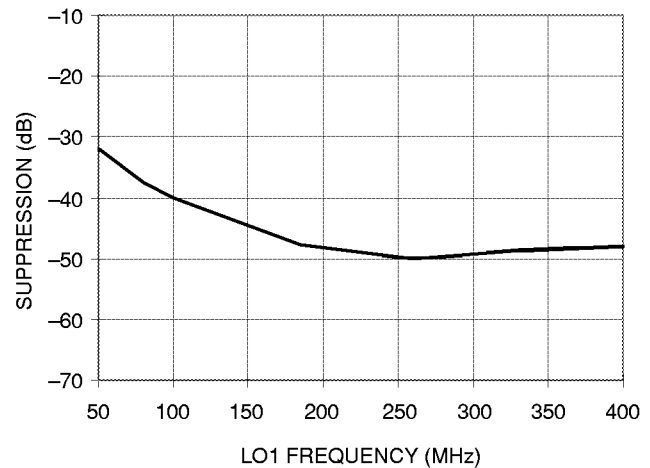

Figure 7. Carrier Suppression vs. LO1 Frequency

Characteristic Curves (continued)

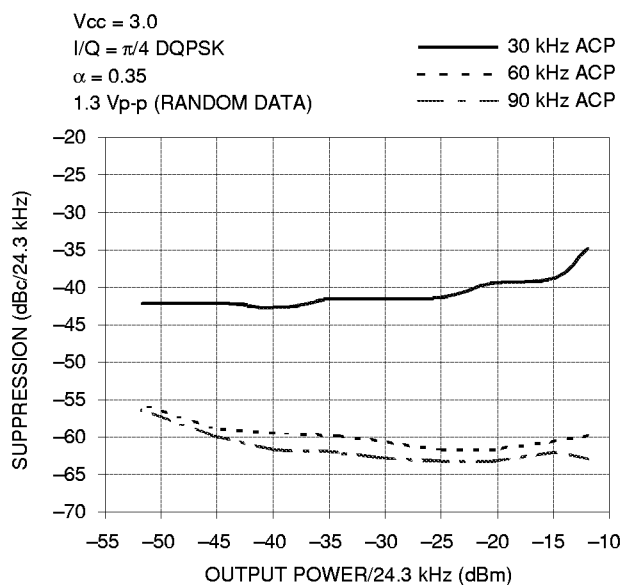

Figure 8. Adjacent Channel Suppression for IS-136 vs. 1900 MHz Output Power

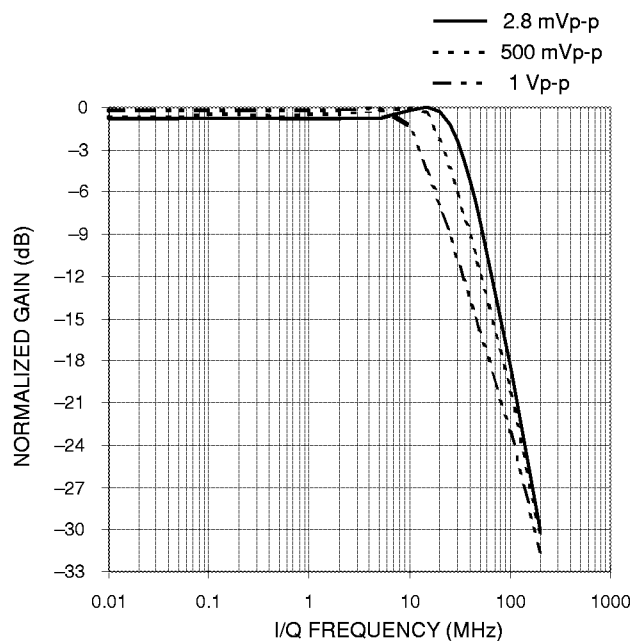

Figure 10. IQ Bandwidth vs. ac Input Voltage

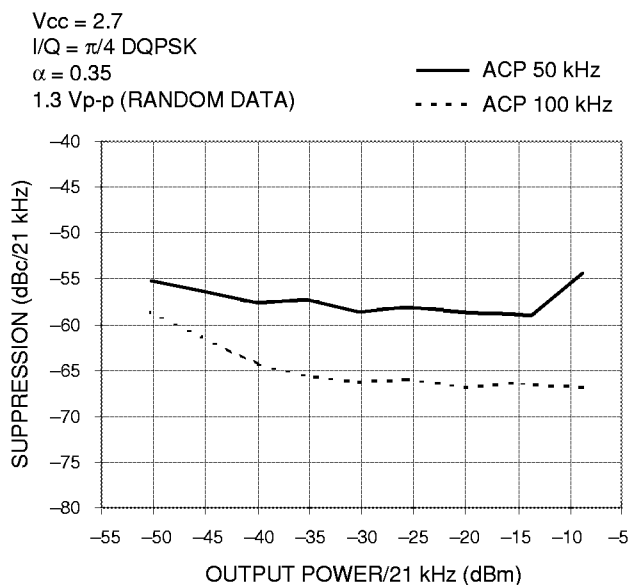

Figure 9. Adjacent Channel Suppression for PDC vs. 940 MHz Output Power

RF Output Impedance

The output impedance of the RF output pin is shown in Figure 11 and Table 3.

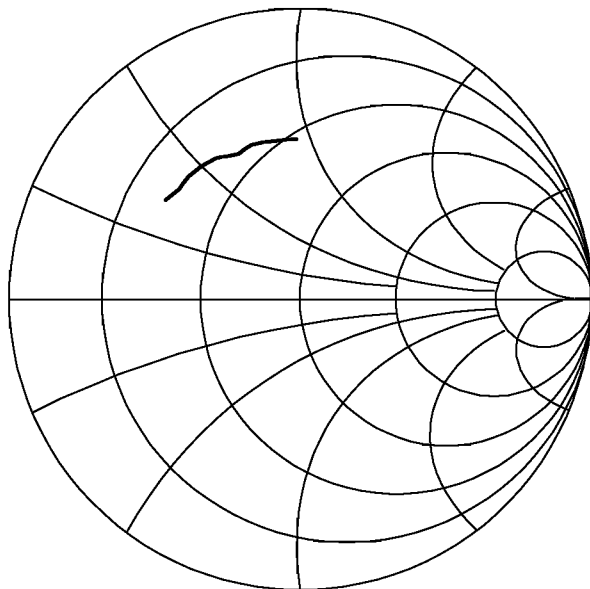

Figure 11. RF_{OUT} Impedance at Pin 19 Contact with Board (800 MHz to 2000 MHz)

Table 3. RF_{OUT} Representative Impedances

Frequency, MHz	R + jX, Ω	Frequency, MHz	R + jX, Ω
800	15.26 + j16.09	1440	19.04 + j29.57
840	15.48 + j16.98	1480	19.45 + j30.36
880	15.71 + j17.82	1520	19.91 + j31.11
920	16.21 + j18.77	1560	20.31 + j31.63
960	16.20 + j19.32	1600	20.75 + j32.14
1000	16.30 + j20.17	1640	20.72 + j32.78
1040	16.55 + j20.96	1680	20.67 + j33.74
1080	16.66 + j21.77	1720	20.88 + j34.94
1120	16.84 + j22.61	1760	21.18 + j36.44
1160	16.92 + j23.51	1800	21.86 + j37.98
1200	17.08 + j24.34	1840	22.44 + j39.51
1240	17.27 + j25.23	1880	23.53 + j40.99
1280	17.48 + j26.17	1920	24.09 + j42.80
1320	17.75 + j27.08	1960	24.98 + j44.50
1360	18.12 + j27.98	2000	26.01 + j46.62
1400	18.53 + j28.90		

Package Outline

20-Pin TSSOP

Dimensions are in millimeters.

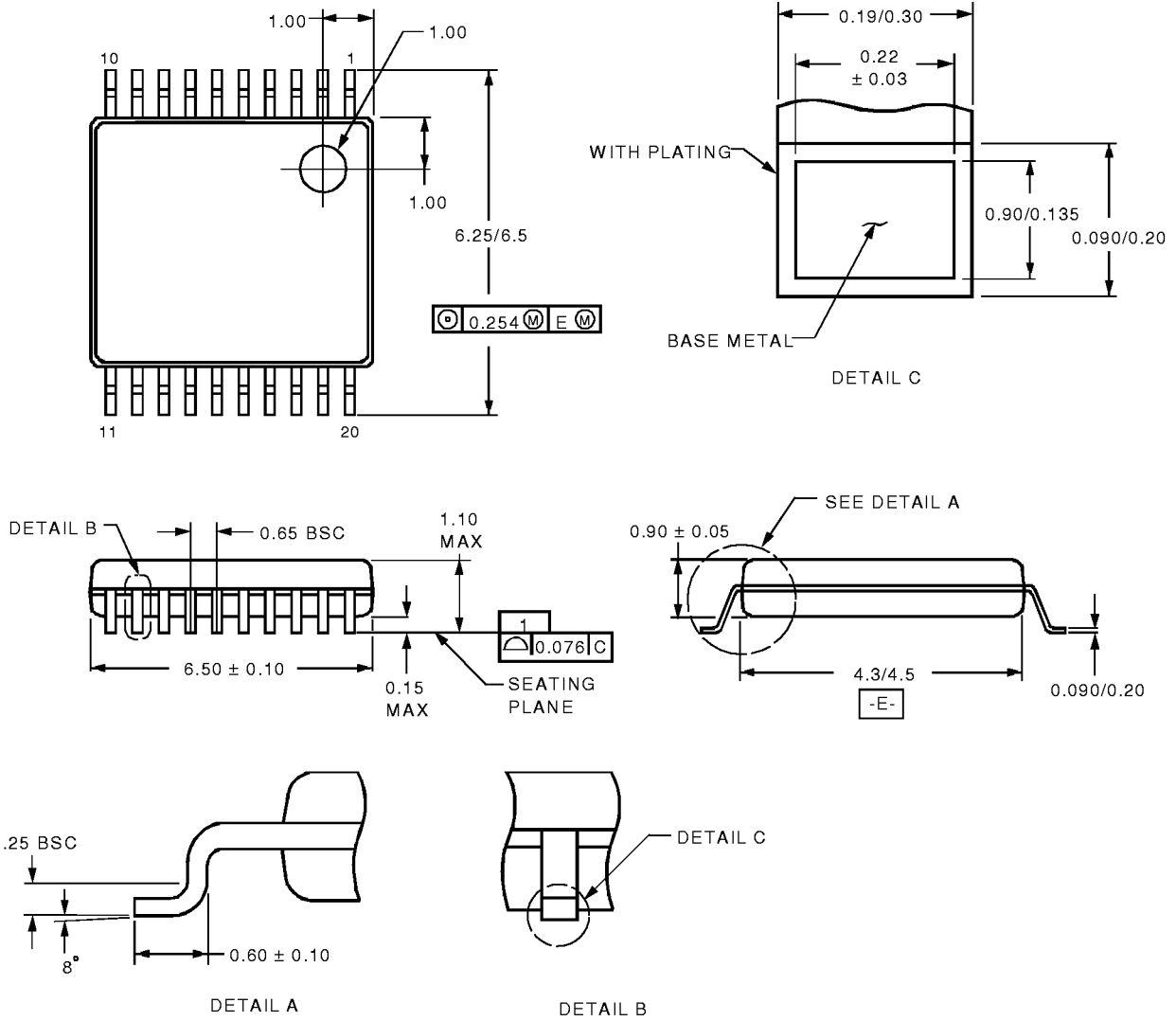

5-5499.r2

Manufacturing Information

This device will be assembled in one of the following locations: assembly codes P, M, or T.

Ordering Information

Device Code	Description	Package	Comcode
W3013BCL	Indirect RF Modulator	20-pin TSSOP	107 956 492
W3013BCL-TR *	—	20-pin TSSOP, tape and reel	107 956 518
EVB3013A	Evaluation Board	—	108 051 574

* Contact your Microelectronics Group Account Manager for minimum order requirements.

For additional information, contact your Microelectronics Group Account Manager or the following:

INTERNET: <http://www.lucent.com/micro>

E-MAIL: docmaster@micro.lucent.com

N. AMERICA: Microelectronics Group, Lucent Technologies Inc., 555 Union Boulevard, Room 30L-15P-BA, Allentown, PA 18103
1-800-372-2447, FAX 610-712-4106 (In CANADA: 1-800-553-2448, FAX 610-712-4106)

ASIA PACIFIC: Microelectronics Group, Lucent Technologies Singapore Pte. Ltd., 77 Science Park Drive, #03-18 Cintech III, Singapore 118256
Tel. (65) 778 8833, FAX (65) 777 7495

CHINA: Microelectronics Group, Lucent Technologies (China) Co., Ltd., A-F2, 23/F, Zao Fong Universe Building, 1800 Zhong Shan Xi Road, Shanghai 200233 P.R. China Tel. (86) 21 6440 0468, ext. 316, FAX (86) 21 6440 0652

JAPAN: Microelectronics Group, Lucent Technologies Japan Ltd., 7-18, Higashi-Gotanda 2-chome, Shinagawa-ku, Tokyo 141, Japan
Tel. (81) 3 5421 1600, FAX (81) 3 5421 1700

EUROPE: Data Requests: MICROELECTRONICS GROUP DATALINE: Tel. (44) 1189 324 299, FAX (44) 1189 328 148

Technical Inquiries: GERMANY: (49) 89 95086 0 (Munich), UNITED KINGDOM: (44) 1344 865 900 (Ascot),
FRANCE: (33) 1 40 83 68 00 (Paris), SWEDEN: (46) 8 594 607 00 (Stockholm), FINLAND: (358) 9 4354 2800 (Helsinki),
ITALY: (39) 02 6608131 (Milan), SPAIN: (34) 1 807 1441 (Madrid)

Lucent Technologies Inc. reserves the right to make changes to the product(s) or information contained herein without notice. No liability is assumed as a result of their use or application.
No rights under any patent accompany the sale of any such product(s) or information.

