

16-CHARACTER 3-LINE DOT MATRIX LCD CONTROLLER DRIVER

■ GENERAL DESCRIPTION

The NJU6463 is a Dot Matrix LCD controller driver for 16-character 3-line with icon display in single chip.

It contains voltage converter and regulator, bleeder resistance, CR oscillator, microprocessor interface circuits, instruction decoder controller, character generator ROM/RAM, high voltage operation common and segment drivers.

The voltage converter generates high voltage (about 8V) from the supply voltage (3V) and it is regulated by the regulator. The bias level of LCD driving voltage is generated of high value of bleeder resistance and the buffer amplifire convert its impedance. The 16th gray scale contrast control function is incorporated for its adjustment. Therefore, simple power supply circuit and easy contrast adjustment are available.

The complete CR oscillator is incorporated, therefore no external components for oscillation circuit are required.

The microprocessor interface circuits which operate by 1MHz, can be selected serial, 4 or 8 bit interface.

The character generator ROM consists of 10,080 bits stores 252 kinds of character Font. Each 160 bits CG RAM and Icon display RAM can stores 4 kinds of special character displayed on the dot matrix display area or 152 kind of Icon on the Icon display area.

The 29-common (24 for character, 4 for icon and 1 for static) and 83-segment (80 for character, 2 for icon and 1 for static) drivers operated up to 13.5V drives 16-character 3-line with 152 Icon and static segment LCD display.

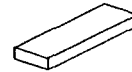
■ PACKAGE OUTLINE

NJU6463C

■ FEATURES

- 16-character 3-line Dot Matrix LCD Controller Driver
- Maximum 152 Icon Display
- Serial, 4 or 8 Bit parallel Direct Interface with Microprocessor
- Display Data RAM - 48 x 8 bits : Maximum 16-character 3-line Display
- Character Generator ROM - 10,080 bits : 252 Characters for 5 x 7 Dots
- Character Generator RAM - 32 x 5 bits : 4 Patterns (5 x 7 Dots)
- Icon Display RAM - 32 x 5 bits : Maximum 152 Icon
- High Voltage LCD Driver : 29-common / 83-segment
- Duty and Bias Ratio : 1/28 duty and 1/6.3 bias
- Useful Instruction Set : Clear Display, Return Home, Display ON/OFF Cont, Cursor ON/OFF Cont, Display Blink, Cursor Shift, Character Shift
- Common and Segment driver Location order Select Function (Mode A/Mode B)
- Power On Initialization / Hardware Reset
- Voltage Converter and Bleeder Resistance on-chip
- Voltage regulator on-chip
- Software contrast control
- Oscillation Circuit on-chip
- Low Power Consumption
- Operating Voltage --- 2.4 to 3.6 V (Except LCD Driving Voltage)
- Package Outline --- Chip / Bumped Chip / TCP
- C-MOS Technology

■ PAD LOCATION

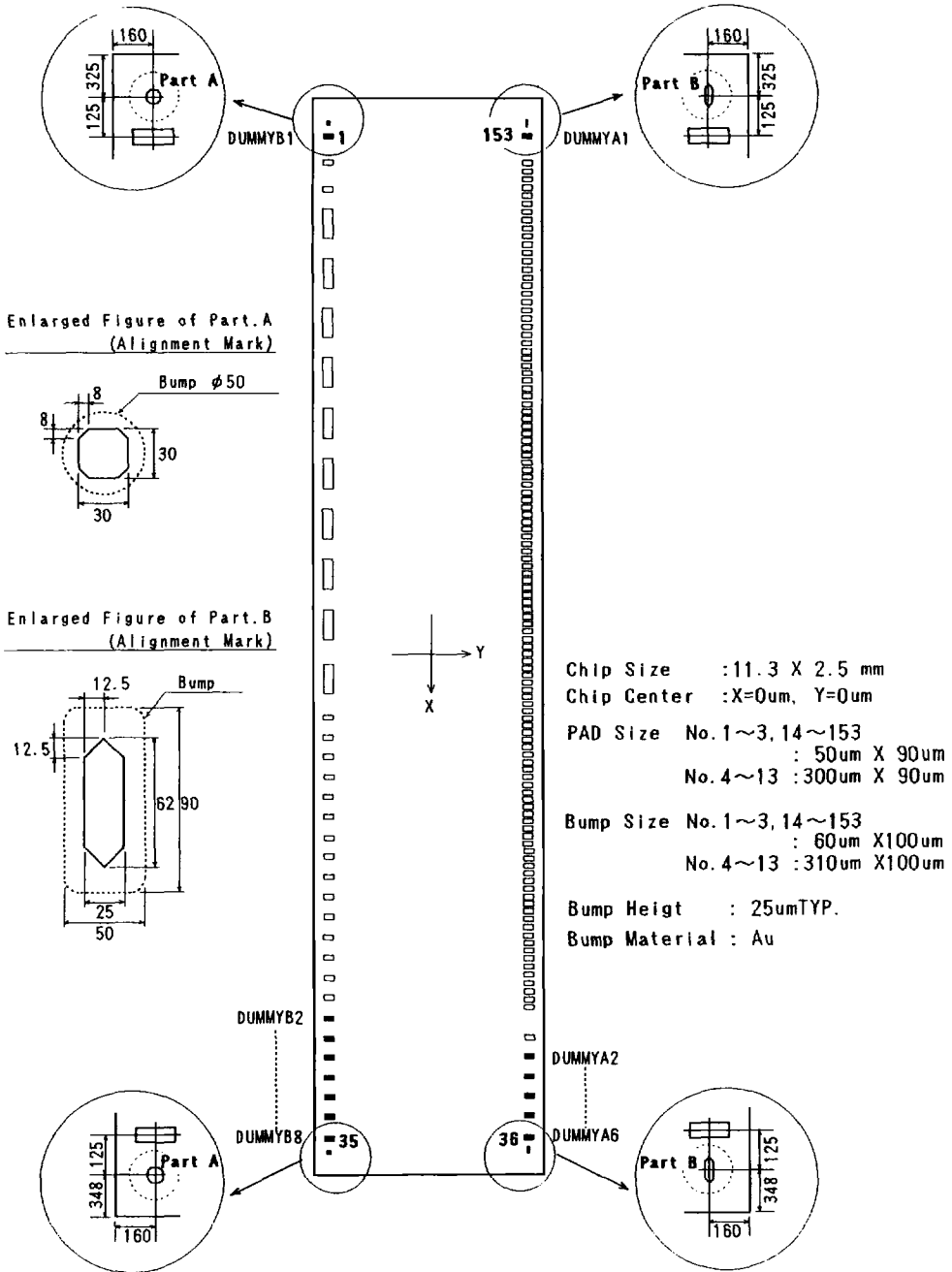

UNIT : μm

■ PAD COORDINATES

 CHIP SIZE 11.3mm x 2.5mm (CHIP CENTER X=0 μ m, Y=0 μ m)

PAD No.	PAD NAME		X=(μ m)	Y=(μ m)
	Mode A	Mode B		
1	DUMMYB	DUMMYB ₁	-5200	-1090
2	CLK ₁	CLK ₁	-4980	-1090
3	CLK ₂	CLK ₂	-4735	-1090
4	V ₅	V ₅	-4439	-1090
5	V _{SS}	V _{SS}	-3939	-1090
6	V _{5OUT}	V _{5OUT}	-3439	-1090
7	C ₂ ⁻	C ₂ ⁻	-2939	-1090
8	C ₂ ⁺	C ₂ ⁺	-2439	-1090
9	C ₁ ⁻	C ₁ ⁻	-1939	-1090
10	C ₁ ⁺	C ₁ ⁺	-1439	-1090
11	V _{DD}	V _{DD}	- 939	-1090
12	VR	VR	- 439	-1090
13	V _{REG}	V _{REG}	61	-1090
14	TEST	TEST	509	-1090
15	SEL	SEL	738	-1090
16	RESET	RESET	966	-1090
17	P/S	P/S	1195	-1090
18	RS	RS	1423	-1090
19	R/W	R/W	1652	-1090
20	E/SCL	E/SCL	1880	-1090
21	DB ₀	DB ₀	2118	-1090
22	DB ₁	DB ₁	2355	-1090
23	DB ₂	DB ₂	2592	-1090
24	DB ₃	DB ₃	2829	-1090
25	DB ₄	DB ₄	3066	-1090
26	DB ₅	DB ₅	3303	-1090
27	DB ₆ /SIO	DB ₆ /SIO	3540	-1090
28	DB ₇ /CS	DB ₇ /CS	3777	-1090
29	DUMMYB ₂	DUMMYB ₂	3977	-1090
30	DUMMYB ₃	DUMMYB ₃	4177	-1090
31	DUMMYB ₄	DUMMYB ₄	4377	-1090
32	DUMMYB ₅	DUMMYB ₅	4577	-1090
33	DUMMYB ₆	DUMMYB ₆	4777	-1090
34	DUMMYB ₇	DUMMYB ₇	4977	-1090
35	DUMMYB ₈	DUMMYB ₈	5177	-1090
36	DUMMYA ₆	DUMMYA ₆	5177	1090
37	DUMMYA ₅	DUMMYA ₅	4977	1090
38	DUMMYA ₄	DUMMYA ₄	4777	1090
39	DUMMYA ₃	DUMMYA ₃	4577	1090
40	DUMMYA ₂	DUMMYA ₂	4400	1090
41	SEGS ₁	SEGS ₁	4200	1090
42	COM ₉	COM ₉	3820	1090
43	COM ₁₀	COM ₁₀	3740	1090
44	COM ₁₁	COM ₁₁	3660	1090
45	COM ₁₂	COM ₁₂	3580	1090
46	COM ₁₃	COM ₁₃	3500	1090
47	COM ₁₄	COM ₁₄	3420	1090
48	COM ₁₅	COM ₁₅	3340	1090
49	COM ₁₆	COM ₁₆	3260	1090
50	SEGM ₁	SEGM ₂	3180	1090

PAD No.	PAD NAME		X=(μ m)	Y=(μ m)
	Mode A	Mode B		
51	SEG ₁	SEG ₈₀	3100	1090
52	SEG ₂	SEG ₇₉	3020	1090
53	SEG ₃	SEG ₇₈	2940	1090
54	SEG ₄	SEG ₇₇	2860	1090
55	SEG ₅	SEG ₇₆	2780	1090
56	SEG ₆	SEG ₇₅	2700	1090
57	SEG ₇	SEG ₇₄	2620	1090
58	SEG ₈	SEG ₇₃	2540	1090
59	SEG ₉	SEG ₇₂	2460	1090
60	SEG ₁₀	SEG ₇₁	2380	1090
61	SEG ₁₁	SEG ₇₀	2300	1090
62	SEG ₁₂	SEG ₆₉	2220	1090
63	SEG ₁₃	SEG ₆₈	2140	1090
64	SEG ₁₄	SEG ₆₇	2060	1090
65	SEG ₁₅	SEG ₆₆	1980	1090
66	SEG ₁₆	SEG ₆₅	1900	1090
67	SEG ₁₇	SEG ₆₄	1820	1090
68	SEG ₁₈	SEG ₆₃	1740	1090
69	SEG ₁₉	SEG ₆₂	1660	1090
70	SEG ₂₀	SEG ₆₁	1580	1090
71	SEG ₂₁	SEG ₆₀	1500	1090
72	SEG ₂₂	SEG ₅₉	1420	1090
73	SEG ₂₃	SEG ₅₈	1340	1090
74	SEG ₂₄	SEG ₅₇	1260	1090
75	SEG ₂₅	SEG ₅₆	1180	1090
76	SEG ₂₆	SEG ₅₅	1100	1090
77	SEG ₂₇	SEG ₅₄	1020	1090
78	SEG ₂₈	SEG ₅₃	940	1090
79	SEG ₂₉	SEG ₅₂	860	1090
80	SEG ₃₀	SEG ₅₁	780	1090
81	SEG ₃₁	SEG ₅₀	700	1090
82	SEG ₃₂	SEG ₄₉	620	1090
83	SEG ₃₃	SEG ₄₈	540	1090
84	SEG ₃₄	SEG ₄₇	460	1090
85	SEG ₃₅	SEG ₄₆	380	1090
86	SEG ₃₆	SEG ₄₅	300	1090
87	SEG ₃₇	SEG ₄₄	220	1090
88	SEG ₃₈	SEG ₄₃	140	1090
89	SEG ₃₉	SEG ₄₂	60	1090
90	SEG ₄₀	SEG ₄₁	- 20	1090
91	SEG ₄₁	SEG ₄₀	- 100	1090
92	SEG ₄₂	SEG ₃₉	- 180	1090
93	SEG ₄₃	SEG ₃₈	- 260	1090
94	SEG ₄₄	SEG ₃₇	- 340	1090
95	SEG ₄₅	SEG ₃₆	- 420	1090
96	SEG ₄₆	SEG ₃₅	- 500	1090
97	SEG ₄₇	SEG ₃₄	- 580	1090
98	SEG ₄₈	SEG ₃₃	- 660	1090
99	SEG ₄₉	SEG ₃₂	- 740	1090
100	SEG ₅₀	SEG ₃₁	- 820	1090

PAD No.	PAD NAME		X=(μ m)	Y=(μ m)
	Mode A	Mode B		
101	SEG ₅	SEG ₃₀	- 900	1090
102	SEG ₅	SEG ₂₉	- 980	1090
103	SEG ₅₃	SEG ₂₈	-1060	1090
104	SEG ₅₄	SEG ₂₇	-1140	1090
105	SEG ₅₅	SEG ₂₆	-1220	1090
106	SEG ₅₆	SEG ₂₅	-1300	1090
107	SEG ₅₇	SEG ₂₄	-1380	1090
108	SEG ₅₈	SEG ₂₃	-1460	1090
109	SEG ₅₉	SEG ₂₂	-1540	1090
110	SEG ₆₀	SEG ₂₁	-1620	1090
111	SEG ₆₁	SEG ₂₀	-1700	1090
112	SEG ₆₂	SEG ₁₉	-1780	1090
113	SEG ₆₃	SEG ₁₈	-1860	1090
114	SEG ₆₄	SEG ₁₇	-1940	1090
115	SEG ₆₅	SEG ₁₆	-2020	1090
116	SEG ₆₆	SEG ₁₅	-2100	1090
117	SEG ₆₇	SEG ₁₄	-2180	1090
118	SEG ₆₈	SEG ₁₃	-2260	1090
119	SEG ₆₉	SEG ₁₂	-2340	1090
120	SEG ₇₀	SEG ₁₁	-2420	1090
121	SEG ₇₁	SEG ₁₀	-2500	1090
122	SEG ₇₂	SEG ₉	-2580	1090
123	SEG ₇₃	SEG ₈	-2660	1090
124	SEG ₇₄	SEG ₇	-2740	1090
125	SEG ₇₅	SEG ₆	-2820	1090
126	SEG ₇₆	SEG ₅	-2900	1090
127	SEG ₇₇	SEG ₄	-2980	1090
128	SEG ₇₈	SEG ₃	-3060	1090
129	SEG ₇₉	SEG ₂	-3140	1090
130	SEG ₈₀	SEG ₁	-3220	1090
131	SEGM ₂	SEGM ₁	-3300	1090
132	COM ₂₄	COM ₂₄	-3380	1090
133	COM ₂₃	COM ₂₃	-3460	1090
134	COM ₂₂	COM ₂₂	-3540	1090
135	COM ₂₁	COM ₂₁	-3620	1090
136	COM ₂₀	COM ₂₀	-3700	1090
137	COM ₁₉	COM ₁₉	-3780	1090
138	COM ₁₈	COM ₁₈	-3860	1090
139	COM ₁₇	COM ₁₇	-3940	1090
140	COM ₈	COM ₈	-4020	1090
141	COM ₇	COM ₇	-4100	1090
142	COM ₆	COM ₆	-4180	1090
143	COM ₅	COM ₅	-4260	1090
144	COM ₄	COM ₄	-4340	1090
145	COM ₃	COM ₃	-4420	1090
146	COM ₂	COM ₂	-4500	1090
147	COM ₁	COM ₁	-4580	1090
148	COMM ₄	COMM ₄	-4660	1090
149	COMM ₃	COMM ₃	-4740	1090
150	COMM ₂	COMM ₂	-4820	1090

PAD No.	PAD NAME		X=(μ m)	Y=(μ m)
	Mode A	Mode B		
151	COMM ₁	COMM ₁	-4900	1090
152	COMS ₁	COMS ₁	-5005	1090
153	DUMMYA ₁	DUMMYA ₁	-5200	1090

■ BLOCK DIAGRAM

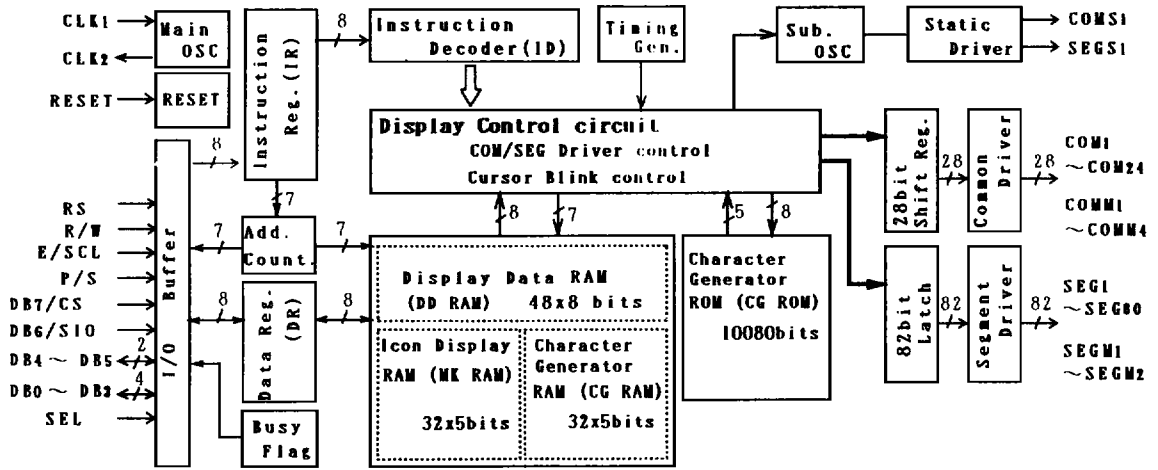

LCD Driving Voltage

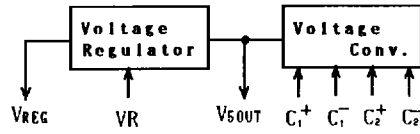
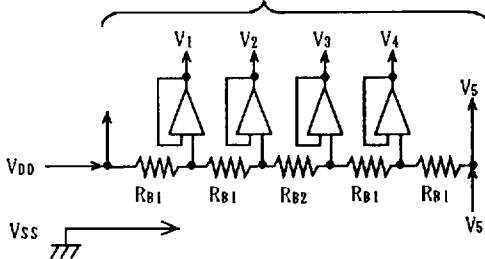

■ TERMINAL DESCRIPTION

No.	SYMBOL	I/O	FUNCTION
11, 5	V_{DD}, V_{SS}		Power Source V_{DD} ; +3V, V_{SS} ; 0V
4	V_S		LCD driving voltage
2	CLK_1	I	System clock input terminal This terminal should be open, for internal clock operation.
3	CLK_2	O	System clock output terminal This terminal can use for clock frequency monitoring.
17	P/S	I	Parallel or serial interface selection terminal "0": Serial interface "1": Parallel interface
18	RS	I	Register selection signal input terminal "0": Instruction register (writing) Busy flag, address counter (reading) "1": Data register (writing / reading)
19	R/W	I	Read / Write selection signal input terminal "0": Write "1": Read
20	E	I	Read / Write activation signal input in parallel mode
	SCL	I	Shift clock input in serial mode
28	DB_7	I/O	3-state data bus for MSB to transfer the Data between MPU and NJU6463 in parallel mode DB_7 is also used for the Busy Flag reading.
	CS	I	Chip select signal input in serial mode
27	DB_6	I/O	3-state data bus for bit 6 to transfer the Data between MPU and NJU6463 in parallel mode
	SIO	I/O	Serial Data I/O in serial mode
25, 26	DB_4, DB_5	I/O	3-state data bus for bit 4 and 5 to transfer the Data between MPU and NJU6463 in parallel mode In serial mode, these terminals are not used and should be open.
21~24	$DB_0 \sim DB_3$	I/O	3-state data bus for lower 4 bits to transfer the Data between MPU and NJU6463 in parallel mode In serial and 4-bit parallel mode, these terminals are not used and should be open.
42~49 132~147	$COM_1 \sim COM_{24}$	O	LCD common driving signal output terminals
148~151	$COMM_1 \sim COMM_4$	O	Icon common driving signal output terminals
152	$COMS_1$	O	Static driving common signal output terminal When power down mode, V_{DD} or V_{SS} level are output.
51~130	$SEG_1 \sim SEG_{80}$	O	LCD segment driving signal output terminals
131, 50	$SEGM_1, SEGM_2$	O	Icon segment driving signal output terminals
41	$SEGS_1$	O	Static Driving Segment signal output terminal When power down mode, V_{DD} or V_{SS} level are output.

No.	SYMBOL	I/O	FUNCTION
7~10	C_1^+ , C_1^- C_2^+ , C_2^-		Step up voltage capacitor connecting terminals In case of tripler operation, connect the capacitor between C_1^+ and C_1^- , C_2^+ and C_2^- . In case of doubler operation, connect the capacitor between C_2^+ and C_2^- , connect C_2^+ to C_1^+ , and C_1^- should be open.
6	V_{5OUT}	0	Step up voltage output terminal
13	V_{REG}	0	Voltage regulator output terminal Connect the resistor between this terminal and VR Terminal.
12	VR		Reference voltage for voltage regulator input terminal Connect the resistor between this terminal and V_{DD} terminal.
16	\overline{RESET}	I	Reset Terminal When the "L" level input over than 1.2ms to this terminal, the system will be reset (at $f_{osc}=180KHz$).
15	SEL	I	Common and Segment driver location order select terminal "0": Mode A location (See the PAD COORDINATES.) "1": Mode B location (See the PAD COORDINATES.)
14	TEST	I	Maker Testing Terminal (Pull down) This terminal should be connected to VSS or open.
29~34 37~40	DUMMYB ₂ ~ DUMMYB ₇ DUMMYA ₂ ~ DUMMYA ₅		Dummy terminal These terminals are electrically open.
1 35 153 36	DUMMYB ₁ DUMMYB ₈ DUMMYA ₁ DUMMYA ₆		Dummy terminal These terminals are electrically open and an alignment pattern is placed beside each terminals.

■ FUNCTIONAL DESCRIPTION

(1) Description for each block

(1-1) Register

The NJU6463 incorporates two 8-bit registers, an Instruction Register (IR) and a Data Register (DR). The Register (IR) stores instruction codes such as "Clear Display" and "Cursor Shift" or address data for Display Data RAM (DD RAM), Character Generator RAM (CG RAM) and Icon Display RAM (MK RAM).

The MPU can write the instruction code and address data to the Register (IR), but it cannot read out from the Register (IR).

The Register (DR) is a temporary stored register, the data stored in the Register (DR) is written into the DD RAM, CG RAM or MK RAM and read out from the DD RAM, CG RAM or MK RAM.

The data in the Register (DR) written by the MPU is transferred automatically to the DD RAM, CG RAM or MK RAM by internal operation.

When the address data for the DD RAM, CG RAM or MK RAM is written into the Register (IR), the addressed data in the DD RAM, CG RAM or MK RAM is transferred to the Register (DR).

By the MPU read out the data in the Register (DR), the data transmitting process is performed completely.

After reading the data in the Register (DR) by the MPU, the next address data in the DD RAM, CG RAM or MK RAM is transferred automatically to the Register (DR) to provide for the next MPU reading.

These two registers are selected by the selection signal RS as shown below.

Table 1. shows register operation controlled by RS and R/W signals.

Table 1. Register Operation

RS	R/W	Selected Register	Operation
0	0	IR	Write
0	1		Read busy flag (DB ₇) and address counter (DB ₀ ~DB ₆)
1	0	DR	Write (Register (DR) to DD RAM, CG RAM or MK RAM)
1	1		Read (DD RAM, CG RAM or MK RAM to Register (DR))

(1-2) Busy Flag (BF)

When the internal circuits are in the operation mode, the busy flag (BF) is "1", and any instruction reading is inhibited.

The busy flag (BF) is output at DB₇ when RS="0" and R/W="1" as shown in Table 1.

The next instruction should be written after the busy flag (BF) goes to "0".

(1-3) Address Counter (AC)

The address counter (AC) addresses the DD RAM, CG RAM or MK RAM.

When the address setting instruction is written into the Register (IR), the address information is transferred from Register (IR) to the Counter (AC). The selection of either the DD RAM, CG RAM or MK RAM is also determined by this instruction.

After writing (or reading) the display data to (or from) the DD RAM, CG RAM or MK RAM, the Counter (AC) increments (or decrements) automatically.

The address data in the Counter (AC) is output from DB₆~DB₀ when RS="0" and R/W="1" as shown in Table 1.

(1-4) Display Data RAM (DD RAM)

The display data RAM (DD RAM) consists of 48 x 8 bits stores up to 48-character display data represented in 8-bit code.

The DD RAM address data set in the address counter(AC) is represented in Hexadecimal.

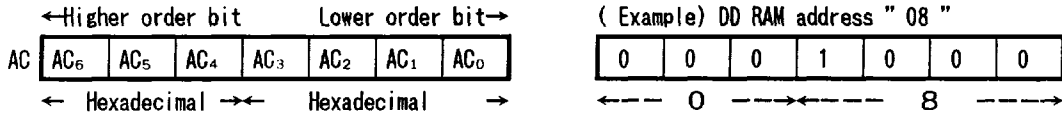

• 3-line Display

The relation between DD RAM address and display position on the LCD is shown below.

	1	2	3	4	5	6	7	8	9	10	11	12	13	14	15	16	← Display Position
1st Line	00	01	02	03	04	05	06	07	08	09	0A	0B	0C	0D	0E	0F	
2nd Line	10	11	12	13	14	15	16	17	18	19	1A	1B	1C	1D	1E	1F	← DD RAM Address (Hexadecimal)
3rd Line	20	21	22	23	24	25	26	27	28	29	2A	2B	2C	2D	2E	2F	

When the display shift is performed, the DD RAM address changes as follows:

(Left Shift Display)

(00) ←	01	02	03	04	05	06	07	08	09	0A	0B	0C	0D	0E	0F	00
(10) ←	11	12	13	14	15	16	17	18	19	1A	1B	1C	1D	1E	1F	10
(20) ←	21	22	23	24	25	26	27	28	29	2A	2B	2C	2D	2E	2F	20

(Right Shift Display)

0F	00	01	02	03	04	05	06	07	08	09	0A	0B	0C	0D	0E	→ (0F)
1F	10	11	12	13	14	15	16	17	18	19	1A	1B	1C	1D	1E	→ (1F)
2F	20	21	22	23	24	25	26	27	28	29	2A	2B	2C	2D	2E	→ (2F)

Note : The left and right shift performs only in same line, the display data do not change to other line.

(1-5) Character Generator ROM (CG ROM)

The Character Generator ROM (CG ROM) generates 5 x 7 dots character pattern represented in 8-bit character code.

The storage capacity is up to 252 kinds of 5 x 7 dots character pattern(available address is (04)_H through (FF)_H).

The correspondence between character code and standard character pattern of NJU6463 is shown in Table 2-1.

User-defined character patterns (Custom Font) are also available by mask option.

Table 2-1. CG ROM Character Pattern (ROM version -02)

		Upper 4 bit (Hexadecimal)																	
		0	1	2	3	4	5	6	7	8	9	A	B	C	D	E	F		
Lower 4 bit (Hexadecimal)	0	CG RAM (01)	0	1	2	3	4	5	6	7	8	9	A	B	C	D	E	F	
	1	(02)	!	"	#	\$	%	&	'	()	*	+	,	-	.	:	;	
	2	(03)	@	A	B	C	D	E	F	G	H	I	J	K	L	M	N	O	P
	3	(04)	Q	R	S	T	U	V	W	X	Y	Z	[]	^	_	`	{	}
	4		~	0	1	2	3	4	5	6	7	8	9	A	B	C	D	E	F
	5		!	"	#	\$	%	&	'	()	*	+	,	-	.	:	;	;
	6		@	A	B	C	D	E	F	G	H	I	J	K	L	M	N	O	P
	7		Q	R	S	T	U	V	W	X	Y	Z	[]	^	_	`	{	}
	8		~	0	1	2	3	4	5	6	7	8	9	A	B	C	D	E	F
	9		!	"	#	\$	%	&	'	()	*	+	,	-	.	:	;	;
	A		@	A	B	C	D	E	F	G	H	I	J	K	L	M	N	O	P
	B		Q	R	S	T	U	V	W	X	Y	Z	[]	^	_	`	{	}
	C		~	0	1	2	3	4	5	6	7	8	9	A	B	C	D	E	F
	D		!	"	#	\$	%	&	'	()	*	+	,	-	.	:	;	;
	E		@	A	B	C	D	E	F	G	H	I	J	K	L	M	N	O	P
	F		Q	R	S	T	U	V	W	X	Y	Z	[]	^	_	`	{	}

(1-6) Character Generator RAM (CG RAM)

The character generator RAM (CG RAM) can store any kind of character pattern in 5 x 7 dots written by the user program to display user's original character pattern. The CG RAM can store 4 kind of character in 5 x 7 dots mode.

To display user's original character pattern stored in the CG RAM, the address data (00)_H - (03)_H should be written to the DD RAM as shown in Table 2-1.

Table 3. show the correspondence among the character pattern, CG RAM address and Data.

Table 3. Correspondence of CG RAM address, DD RAM character code and CG RAM character pattern(5 x 7 dots).

Character Code (DD RAM Data)	CG RAM Address	Character Pattern (CG RAM Data)																																
7 6 5 4 3 2 1 0 ← Upper Bit Lower Bit	7 6 5 4 3 2 1 0 ← Upper Bit Lower Bit	4 3 2 1 0 ← Upper Bit Lower Bit																																
0 0 0 0 0 0 0 0	0 1 0 0 0	<table border="1"> <tr><td>0</td><td>0</td><td>0</td><td>0</td></tr> <tr><td>0</td><td>0</td><td>0</td><td>1</td></tr> <tr><td>0</td><td>1</td><td>0</td><td>0</td></tr> <tr><td>0</td><td>1</td><td>1</td><td>0</td></tr> <tr><td>1</td><td>0</td><td>0</td><td>0</td></tr> <tr><td>1</td><td>0</td><td>1</td><td>0</td></tr> <tr><td>1</td><td>1</td><td>0</td><td>0</td></tr> <tr><td>1</td><td>1</td><td>1</td><td>0</td></tr> </table>	0	0	0	0	0	0	0	1	0	1	0	0	0	1	1	0	1	0	0	0	1	0	1	0	1	1	0	0	1	1	1	0
0	0	0	0																															
0	0	0	1																															
0	1	0	0																															
0	1	1	0																															
1	0	0	0																															
1	0	1	0																															
1	1	0	0																															
1	1	1	0																															

0 0 0 0 0 0 0 1	0 1 0 0 1	<table border="1"> <tr><td>0</td><td>0</td><td>0</td><td>0</td></tr> <tr><td>0</td><td>0</td><td>0</td><td>1</td></tr> <tr><td>0</td><td>1</td><td>0</td><td>0</td></tr> <tr><td>0</td><td>1</td><td>1</td><td>0</td></tr> <tr><td>1</td><td>0</td><td>0</td><td>0</td></tr> <tr><td>1</td><td>0</td><td>1</td><td>0</td></tr> <tr><td>1</td><td>1</td><td>0</td><td>0</td></tr> <tr><td>1</td><td>1</td><td>1</td><td>0</td></tr> </table>	0	0	0	0	0	0	0	1	0	1	0	0	0	1	1	0	1	0	0	0	1	0	1	0	1	1	0	0	1	1	1	0
0	0	0	0																															
0	0	0	1																															
0	1	0	0																															
0	1	1	0																															
1	0	0	0																															
1	0	1	0																															
1	1	0	0																															
1	1	1	0																															

		<table border="1"> <tr><td>0</td><td>0</td><td>0</td><td>0</td></tr> <tr><td>0</td><td>0</td><td>1</td><td></td></tr> <tr><td></td><td></td><td>1</td><td>0</td></tr> <tr><td></td><td></td><td>1</td><td>0</td></tr> <tr><td></td><td></td><td>1</td><td>1</td></tr> <tr><td></td><td></td><td>1</td><td>1</td></tr> </table>	0	0	0	0	0	0	1				1	0			1	0			1	1			1	1								
0	0	0	0																															
0	0	1																																
		1	0																															
		1	0																															
		1	1																															
		1	1																															

Character Pattern Example(1)

←Cursor Position

Character Pattern Example(2)

←Cursor Position

- Notes : 1. Character code bit 0,1 correspond to the CG RAM address bit 3,4(2bits:4 patterns).
- 2. CG RAM address 0 to 2 designate character pattern line position. The 8th line is the cursor position and the display is performed by logical OR with cursor. Therefore, in case of the cursor display, the 8th line should be "0". If there is "1" in the 8th line, the bit "1" is always displayed on the cursor position regardless of cursor existence.
- 3. Character pattern row position correspond to the CG RAM data bits 0 to 4 are shown above.
- 4. CG RAM character patterns are selected when character code bits 2 to 7 are all "0" and these are addressed by character code bits 0 and 1.
- 5. "1" for CG RAM data corresponds to display On and "0" to display Off.

(1-7) Icon Display RAM (MK RAM)

The NJU6463 can display maximum 152 icons.

The Icon Display can be controlled by writing the Data in MK RAM corresponds to the Icon.

The relation between MK RAM address and Icon Display position is shown below:

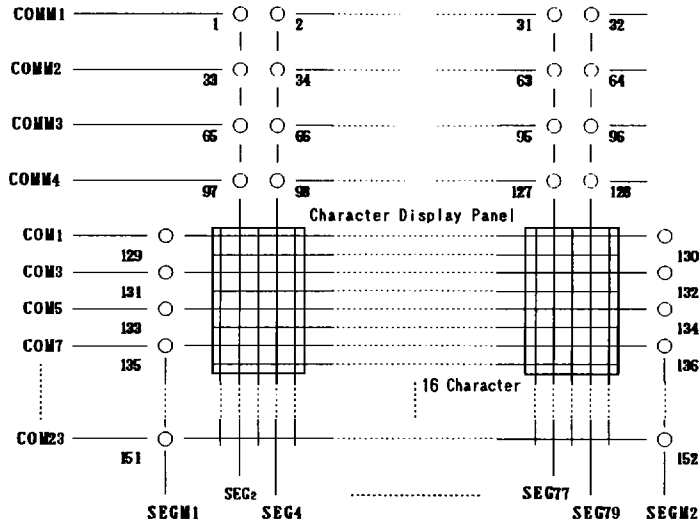

Table 4. Correspondence among Icon Position, MK RAM Address and Data

MK RAM Address	Bits for Icon Display Position							
	D ₇	D ₆	D ₅	D ₄	D ₃	D ₂	D ₁	D ₀
60 _H	*	*	*	1	2	3	4	129
61 _H	*	*	*	5	6	7	8	130
⋮								
67 _H	*	*	*	29	30	31	32	136
68 _H	*	*	*	33	34	35	36	137
69 _H	*	*	*	37	38	39	40	138
⋮								
6F _H	*	*	*	61	62	63	64	144
70 _H	*	*	*	65	66	67	68	145
71 _H	*	*	*	69	70	71	72	146
⋮								
77 _H	*	*	*	93	94	95	96	152
78 _H	*	*	*	97	98	99	100	*
79 _H	*	*	*	101	102	103	104	*
⋮								
7F _H	*	*	*	125	126	127	128	*

* : Don't care

} COMM1 Line and Both sides of 1st Line (COM1,3,5,7)
 } COMM2 Line and Both sides of 2nd Line (COM9,11,13,15)
 } COMM3 Line and Both sides of 3rd Line (COM17,19,21,23)
 } COMM4 Line

- Notes :
- When the Icon display function using, the system should be initialized by the software initialization because the MK RAM is not initialized by the power turning on and hardware reset.
 - The cross-points between SEGM₁, SEGM₂ and some of common COMM₁ through COMM₄, even common lines as COM₂, COM₄...COM₂₄, are always off because of the corresponding RAM does not exist as shown above.
 - In the table 4, the bits D₅ to D₇ mentioned by * are invalid, therefore both of "0" or "1" can be written but these are no meaning.

(1-8) Timing Generator

The timing generator generates a timing signals for the DD RAM, CG RAM and MK RAM and other internal circuits.

RAM read timing for the display and internal operation timing for MPU access are separately generated, so that they may not interfere with each other.

Therefore, when the data write to the DD RAM for example, there will be no undesirable influence, such as flickering, in areas other than the display area.

(1-9) LCD Driver

LCD Driver consists of 29-common driver and 83-segment driver.

The character pattern data are latched to the addressed Segment-register respectively. This latched data controls display driver to output LCD driving waveform.

(1-10) Cursor Blinking Control Circuit

This circuits controls cursor On/Off and the cursor position character blinks.

The cursor or blinks appear in the digit residing at the DD RAM address set in the address counter (AC).

When the address counter is (28)_H, a cursor position is shown as follows:

	AC ₆	AC ₅	AC ₄	AC ₃	AC ₂	AC ₁	AC ₀
(AC)	0	1	0	1	0	0	0

3-Line display

	1	2	3	4	5	6	7	8	9	10	11	12	13	14	15	16	← Display position
1st Line	00	01	02	03	04	05	06	07	08	09	0A	0B	0C	0D	0E	0F	← DD RAM address (Hexadecimal)
2nd Line	10	11	12	13	14	15	16	17	18	19	1A	1B	1C	1D	1E	1F	
3rd Line	20	21	22	23	24	25	26	27	28	29	2A	2B	2C	2D	2E	2F	
																	↑ Cursor position

Note : The cursor or blinks also appear when the address counter (AC) selects the CG RAM or the MK RAM. But the displayed cursor and blink are meaningless.

If the AC storing the CG or MK RAM address data, the cursor and blink are displayed in the meaningless position.

(2) Power on Initialization by internal circuits

(2-1) Initialization By Internal Reset Circuits

The NJU6463 is automatically initialized by internal power on initialization circuits when the power is turned on. In the internal power on initialization, following instructions are executed. During the Internal power on initialization, the busy flag (BF) is "1" and this status is kept 12 ms ($f_{osc}=180kHz$) after V_{DD} rises to 2.4V.

Initialization flow is shown below:

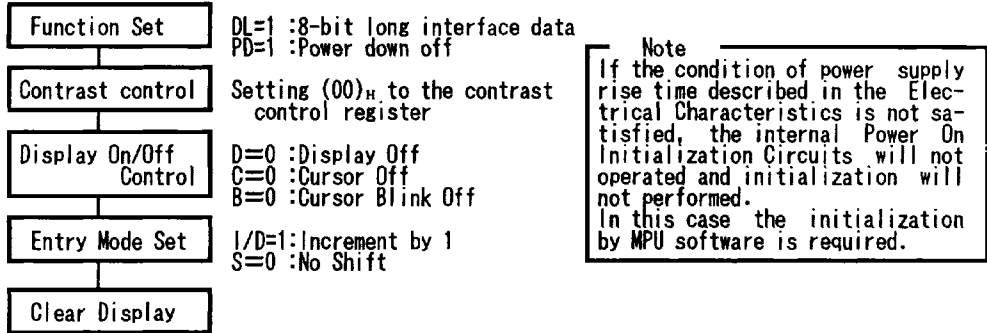

(2-2) Initialization By Hardware

The NJU6463 incorporates \overline{RESET} terminal to initialize the all system. When the "L" level input over 1.2ms to the \overline{RESET} terminal, reset sequence is executed. In this time, busy signal output during 12ms ($f_{osc}=180kHz$) after \overline{RESET} terminal goes to "H".

• Timing Chart

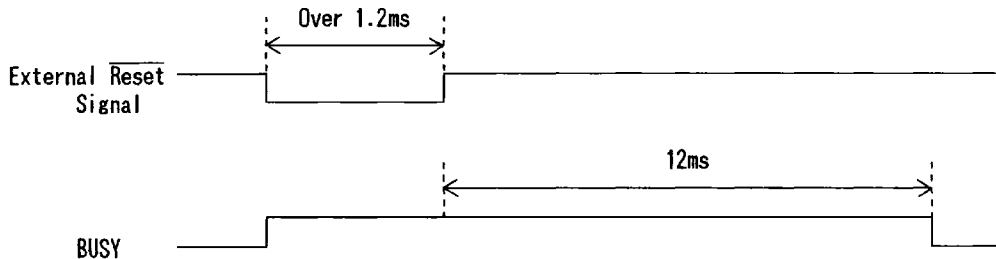

(3) Instructions

The NJU6463 incorporates two registers, an Instruction Register (IR) and a Data Register (DR). These two registers store control information temporarily to allow interface between NJU6463 and MPU or peripheral ICs operating different cycles. The operation of NJU6463 is determined by this control signal from MPU. The control information includes register selection signals (RS), read/write signals (R/W) and data bus signals (DB_0 to DB_7).

Table 5. shows each instruction and its operating time.

Note : The execution time mentioned in Table 5. based on f_{cp} or $f_{osc}=180kHz$.
If the oscillation frequency is changed, the execution time is also changed.

Table 4. Table of Instructions

INSTRUCTIONS	RS	R/W	C DB ₇	D DB ₆	D DB ₅	E DB ₄	E DB ₃	E DB ₂	E DB ₁	E DB ₀	DESCRIPTION	Execute Time
Maker Testing	0	0	0	0	0	0	0	0	0	0	All "0" code is using for maker testing.	-
Clear Display	0	0	0	0	0	0	0	0	0	1	Display clear and sets RAM address (00) _H in AC.	11.398 ms
Return Home	0	0	0	0	0	0	0	0	1	*	Sets RAM address (00) _H in AC and returns display being shifted original position. RAM contents remain unchanged.	456us
Entry Mode Set	0	0	0	0	0	0	0	1	I/D	S	Sets cursor move direction and specifies shift of display are performed in data read/write. I/D=1:Increment, I/D=0:Decremen S=1:Accompanies display shift	456us
Display On/Off Control	0	0	0	0	0	0	1	D	C	B	Sets of display On/Off(D), cursor On/Off(C) and blink of cursor position character(B).	0us
Cursor or Display Shift	0	0	0	0	0	1	S/C	R/L	*	*	Moves cursor & shifts display without changing RAM contents S/C=1 : Display shift S/C=0 : Cursor shift R/L=1 : Shift to the right R/L=0 : Shift to the left	cursor: 456us display: 0us
Function Set	0	0	0	0	1	DL	*	*	*	PD	Sets interface data length(DL) and power down mode(PD).	0us
Contrast control	0	0	0	1	*	*	← C _c →				Sets data to Contrast Control Register.	0us
Set RAM Address	0	0	1	←←←		A _R				→→→	Sets RAM address. After this instruction, the data is transferred to/from RAM.	456us
Read Busy Flag & AC contents	0	1	BF	←←←		AC				→→→	Reads busy flag and AC content BF=1 : Internally operating BF=0 : Can accept instruction	0us
Write Data to RAM	1	0	←← Write Data (DD RAM)				→→				Writes data into RAM.	456us
	1	0	* * *	←← (CG RAM)			→→					
	1	0	* * *	←← (MK RAM)			→→					
Read Data from RAM	1	1	←← Read Data (DD RAM)				→→				Reads data from RAM.	456us
	1	1	* * *	←← (CG RAM)			→→					
	1	1	* * *	←← (MK RAM)			→→					
Explanation of Abbreviation	DD RAM : Display data RAM, CG RAM : Character generator RAM, MK RAM : Icon display RAM, A _R : RAM address (both of DD, CG and MK RAM) AC : Address counter used for both of DD, CG and MK RAM											

* : Don't care

(3-1) Description of each instructions

(a) Maker Testing

	RS	R/W	DB ₇	DB ₆	DB ₅	DB ₄	DB ₃	DB ₂	DB ₁	DB ₀
Code	0	0	0	0	0	0	0	0	0	0

All "0" code in 4-bit length is using for device testing mode (only for maker). Therefore, please avoid all "0" input or no meaning Enable signal input at data "0". (Especially please pay attention the output condition of Enable signal when the power turns on.)

(b) Clear Display

	RS	R/W	DB ₇	DB ₆	DB ₅	DB ₄	DB ₃	DB ₂	DB ₁	DB ₀
Code	0	0	0	0	0	0	0	0	0	1

Clear display instruction is executed when the code "1" is written into DB₀. When this instruction is executed, the space code (20)_H is written into every DD RAM address, the DD RAM address (00)_H is set into the address counter and entry mode is set increment.

If the cursor or blink are displayed, they are returned to the left end of the 1st line in the LCD.

The S of entry mode does not change.

Note: The character pattern for character code (20)_H must be blank code in the user-defined character pattern(Custom font).

(c) Return Home

	RS	R/W	DB ₇	DB ₆	DB ₅	DB ₄	DB ₃	DB ₂	DB ₁	DB ₀	
Code	0	0	0	0	0	0	0	0	1	*	* = Don't care

Return home instruction is executed when the code "1" is written into DB₁. When this instruction is executed, the DD RAM address (00)_H is set into the address counter. Display is returned its original position if shifted, the cursor or blink are returned to the left end of the 1st line in the LCD if the cursor or blink are on the display.

The DD RAM contents do not change.

(d) Entry Mode Set

	RS	R/W	DB ₇	DB ₆	DB ₅	DB ₄	DB ₃	DB ₂	DB ₁	DB ₀
Code	0	0	0	0	0	0	0	1	I/D	S

Entry mode set instruction which sets the cursor moving direction and display shift On/Off, is executed when the code "1" is written into DB₂ and the codes of (I/D) and (S) are written into DB₁(I/D) and DB₀(S), as shown below.

(I/D) sets the address increment or decrement, and the (S) sets the entire display shift in the DD RAM writing.

I/D	F u n c t i o n
1	Address increment: The address of the DD RAM or CG RAM increment (+1) when the read/write, and the cursor or blink move to the right.
0	Address decrement: The address of the DD RAM or CG RAM decrement (-1) when the read/write, and the cursor or blink move to the left.

S	F u n c t i o n
1	Entire display shift. The shift direction is determined by I/D.: shift to the left at I/D=1 and shift to the right at the I/D=0. The shift is operated only for the character, so that it looks as if the cursor stands still and the display moves. The display does not shift when reading from the DD RAM and writing/reading into/from CG RAM.
0	The display does not shift.

(e) Display On/Off Control

	RS	R/W	DB ₇	DB ₆	DB ₅	DB ₄	DB ₃	DB ₂	DB ₁	DB ₀
Code	0	0	0	0	0	0	1	D	C	B

Display On/Off control instruction which controls the whole display On/Off, the cursor On/Off and the cursor position character blink, is executed when the code "1" is written into DB₃ and the codes of (D), (C) and (B) are written into DB₂(D), DB₁(C) and DB₀(B), as shown below.

D	F u n c t i o n
1	Display On.
0	Display Off. In this mode, the display data remains in the DD RAM so that it is retrieved immediately on the display when the D change to 1.

C	F u n c t i o n
1	Cursor On. The cursor is displayed by 5 dots on the 8th line.
0	Cursor Off. Even if the display data write, the I/D etc does not change.

B	F u n c t i o n
1	The cursor position character is blinking. Blinking rate is 480ms at $f_{osc}=180kHz$. The cursor and the blink can be displayed simultaneously.
0	The character does not blink.

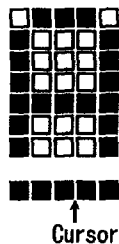

Character Font 5 x 7 dots

(1) Cursor display example

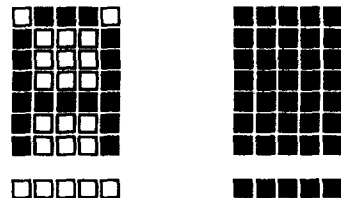

Alternating display

(2) Blink display example

(f) Cursor/Display Shift

	RS	R/W	DB ₇	DB ₆	DB ₅	DB ₄	DB ₃	DB ₂	DB ₁	DB ₀	
Code	0	0	0	0	0	1	S/C	R/L	*	*	* = Don't care

The Cursor/Display shift instruction shifts the cursor position or display to the right or left without writing or reading display data. This function is used to correct or search the display. The cursor moves to the 2nd line when it passes the 16th digit of the 1st line.

Notice that the every 1st to 3rd line displays shift at the same time. When the displayed data are shifted repeatedly, each line moves only horizontally.

The 2nd and 3rd line display does not shift into the 1st and 2nd line.

The contents of address counter(AC) does not change by operation of the display shift only.

This instruction is executed when the code "1" is written into DB₄ and the codes of (S/C) and (R/L) are written into DB₃(S/C) and DB₂(R/L), as shown below.

S/C	R/L	F u n c t i o n
0	0	Shifts the cursor position to the left ((AC) is decremented by 1)
0	1	Shifts the cursor position to the right ((AC) is incremented by 1)
1	0	Shifts the entire display to the left and the cursor follows it.
1	1	Shifts the entire display to the right and the cursor follows it.

(g) Function Set

	RS	R/W	DB ₇	DB ₆	DB ₅	DB ₄	DB ₃	DB ₂	DB ₁	DB ₀	
Code	0	0	0	0	1	DL	*	*	*	PD	* = Don't care

Function set instruction which sets the interface data length and powerdown mode, is executed when the code "1" is written into DB₅ and the code of (DL) and (PD) is written into DB₄(DL) and DB₀(PD), as shown below. In the serial interface operation, the DL is not cared.

When the powerdown mode is set, the display is off automatically (D=0). Afterward, when the powerdown mode is reset, the display is off continuously. The display is appeared by the display on (D="1") instruction.

Note
 This function set instruction must be performed at the head of the program prior to all other existing instructions(except Busy flag/Address read). This function set instruction can not be executed afterwards unless the interface data length change.

DL	F u n c t i o n
1	Set the interface data length of 8-bit (using from DB ₇ to DB ₀) in the parallel operation only
0	Set the interface data length of 4-bit (using from DB ₇ to DB ₄) in the parallel operation only The data must be sent or received twice in this mode.

PD	F u n c t i o n
1	Power down mode off (Normal operation)
0	Power down mode on (The display goes to off automatically.)

(h) Contrast Control

	RS	R/W	DB ₇	DB ₆	DB ₅	DB ₄	DB ₃	DB ₂	DB ₁	DB ₀	
Code	0	0	0	1	*	*	C ₃	C ₂	C ₁	C ₀	* = Don't care

Contrast Control instruction which adjusts the contrast of the LCD, is executed when the code "1" is written into DB₆ and the codes of C₃ to C₀ are written into DB₃ to DB₀ as shown below.

The contrast of LCD can be adjusted one of 16 voltage stage by setting this 4-bit register. See (5-1) to realize "how to adjust the Contrast of LCD".

Set the binary code "0000" when contrast adjustment is unused.

contrast	C ₃	C ₂	C ₁	C ₀
low	0	0	0	0
	⋮	⋮	⋮	⋮
high	1	1	1	1

(i) Set RAM Address

	RS	R/W	DB ₇	DB ₆	DB ₅	DB ₄	DB ₃	DB ₂	DB ₁	DB ₀
Code	0	0	1	A ₆	A ₅	A ₄	A ₃	A ₂	A ₁	A ₀
				←Higher order bit				Lower order bit →		

The RAM address set instruction is executed when the code "1" is written into DB₇ and the address is written into DB₆ to DB₀ as shown above.

The address data (DB₆ to DB₀) is written into the address counter (AC) by this instruction. After this instruction execution, the data writing/reading is performed into/from the addressed RAM.

The RAM includes DD RAM, CG RAM and MK RAM, and these RAMs are shared by address as shown below.

RAM Address

DD RAM	1st Line	:	from (00) _H	to (0F) _H
DD RAM	2nd Line	:	from (10) _H	to (1F) _H
DD RAM	3rd Line	:	from (20) _H	to (2F) _H
CG RAM	4 characters	:	from (40) _H	to (5F) _H
MK RAM	152 icons	:	from (60) _H	to (7F) _H

(j) Read Busy Flag & AC contents

	RS	R/W	DB ₇	DB ₆	DB ₅	DB ₄	DB ₃	DB ₂	DB ₁	DB ₀
Code	0	1	BF	A ₆	A ₅	A ₄	A ₃	A ₂	A ₁	A ₀
				←Higher order bit				Lower order bit →		

This instruction reads out the internal status of the NJU6463. When this instruction is executed, the busy flag (BF) stored in DB₇ and the address counter (AC) contents stored in DB₆ to DB₀ are read out.

The (BF)="1" indicates that internal operation is in progress. The next instruction is inhibited when (BF)="1". Check the (BF) status before the next write operation.

(k) Write Data to RAM

Write Data to RAM instruction is executed when the code "1" is written into (RS) and code "0" is written into (R/W).

By the execution of this instruction, the binary 8-bit data (A₇ to A₀) are written into the DD RAM, and the binary 5-bit data (A₄ to A₀) are written into the CG or MK RAM. The selection of RAM is determined by the previous instruction. After this instruction execution, the address increment (+1) or decrement (-1) is performed automatically according to the entry mode set. And the display shift is also executed according to the previous entry mode set.

• Write Data to DD RAM

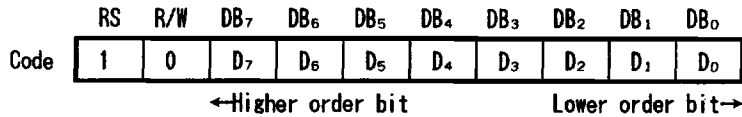

• Write Data to CG or MK RAM

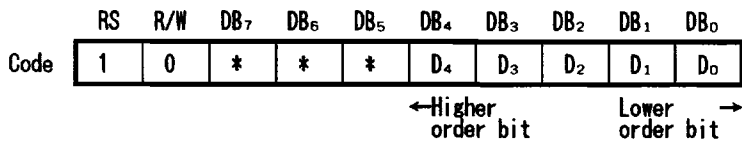

(l) Read Data from RAM

Read Data from RAM instruction is executed when the code "1" is written into (RS) and (R/W).

By the execution of this instruction, the binary 8-bit data (D₇ to D₀) are read out from the DD RAM, the binary 5-bit data (D₇ to D₀) are read out from the CG or MK RAM. The selection of RAM is determined by previous instruction. Before executing this instruction, RAM address set must be executed, otherwise the read out data are invalidated.

When this instruction is serially executed, the next address data is normally read from the second read.

The RAM address set instruction is not required if the cursor shift instruction is executed just beforehand (only DD RAM reading). The cursor shift instruction has same function as the DD RAM address set, so that after reading the DD RAM, the address increment or decrement is executed automatically according to the entry mode.

But display shift does not occur regardless of the entry mode.

Note: The address counter(AC) is automatically incremented or decremented by 1 after write instruction to either of the DD RAM, CG RAM or DD RAM. Even if the read instruction is executed after this write instruction, the addressed data can not be read out correctly. For a correct data read out, either the address set instruction or cursor shift instruction (only with DD RAM) must be implemented just before this instruction or from the second time read out instruction execution if the read out instruction is executed 2 times consecutively.

• Read Data from DD RAM

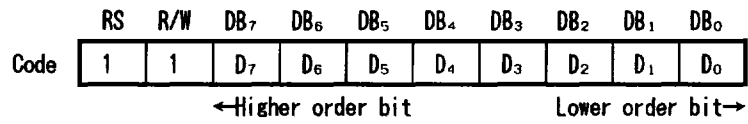

• Read Data from CG or MK RAM

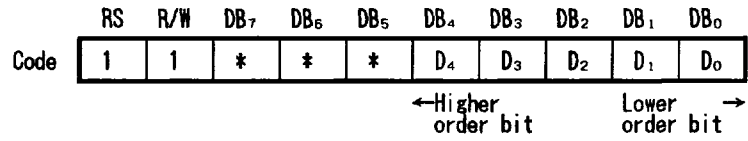

(3-3) Initialization by instruction

If the power supply conditions for the correct operation of the internal reset circuits are not met, the NJU6463 must be initialized by the instruction.

(a) Initialization by Instruction in 8-bit interface length.

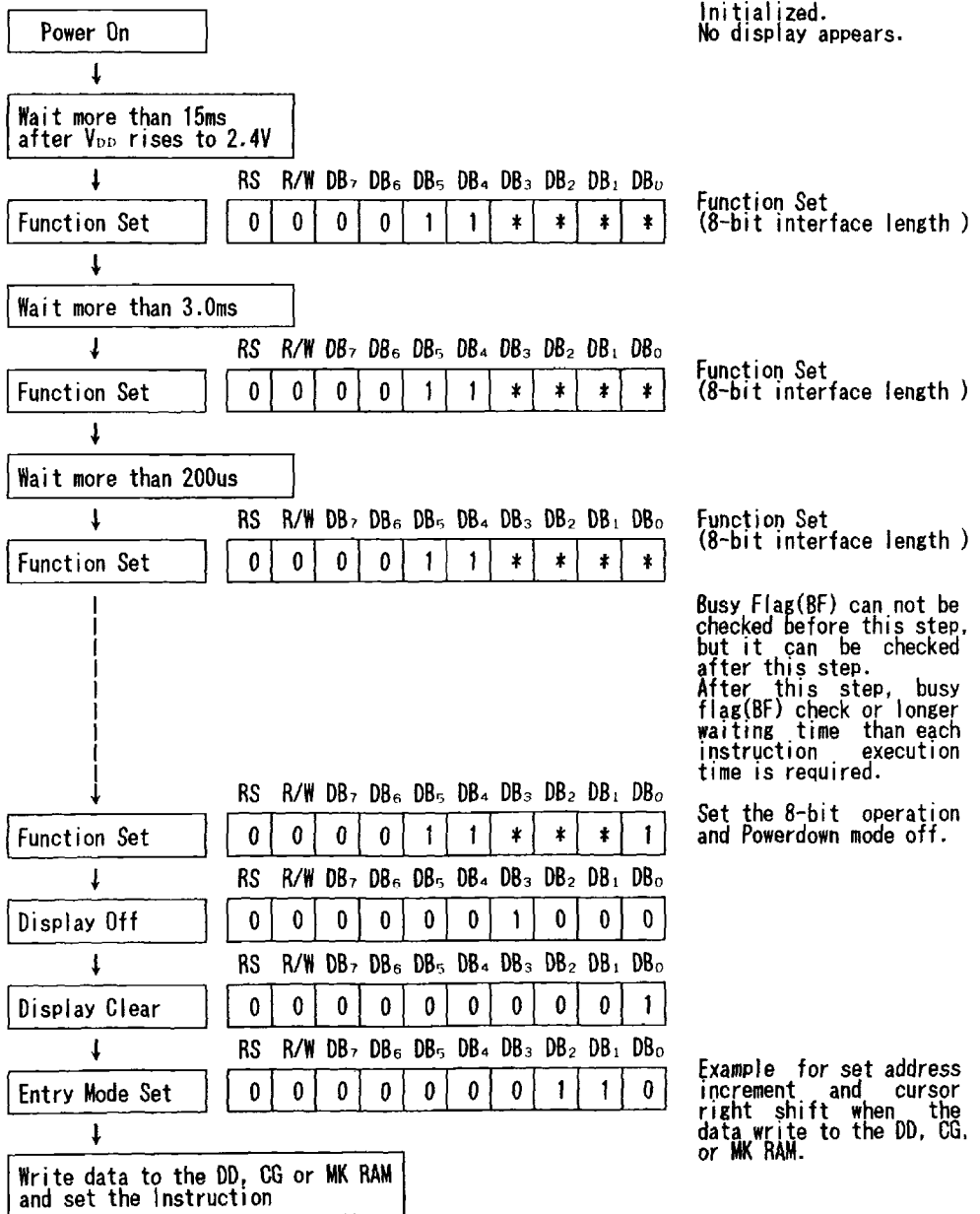

Note: When the Icon display function using, the system should be initialized by software initialization.

(b) Initialization by Instruction in 4-bit interface length

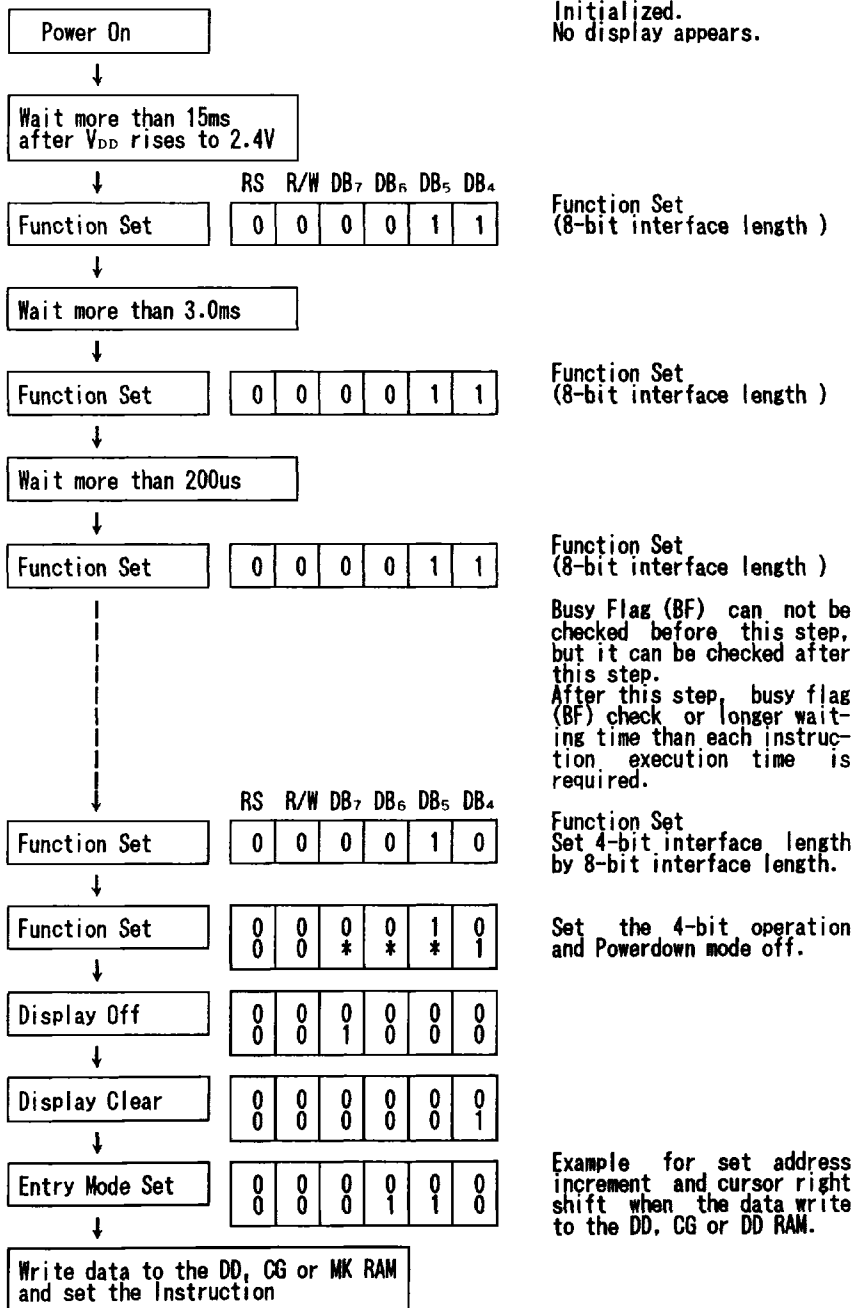

Initialized.
No display appears.

Function Set
(8-bit interface length)

Function Set
(8-bit interface length)

Function Set
(8-bit interface length)

Busy Flag (BF) can not be checked before this step, but it can be checked after this step.
After this step, busy flag (BF) check or longer waiting time than each instruction execution time is required.

Function Set
Set 4-bit interface length by 8-bit interface length.

Set the 4-bit operation and Powerdown mode off.

Example for set address increment and cursor right shift when the data write to the DD, CG or DD RAM.

Note: When the Icon display function using, the system should be initialized by software initialization.

(4) Powerdown Function

NJU6463 incorporates the powerdown mode to decrease the operating current.

The powerdown mode can be set/reset by the function set instruction.

In the powerdown mode, all the character display (16-character 3-line) and icon display turn off and only the static display area operates automatically.

The status of internal circuits at the powerdown mode is shown below :

- Main oscillator stops operation and sub oscillator for the static display starts operation.
- Voltage converter, voltage regulator and buffer amplifire for the bleeder resistance stop the operation.
- The contents of DD RAM, CG RAM and MK RAM are kept.

(5) LCD display

(5-1) Power Supply for LCD Driving

NJU6463 incorporates Voltage converter (tripler or doubler) to generate the LCD driving high voltage, Voltage regulator to adjust the LCD driving voltage, Bleeder resistance and buffer amplifire.

(a) Voltage converter

• Voltage tripler

By connecting the capacitor between C_1^+ and C_1^- , C_2^+ and C_2^- , V_{SS} and V_{5OUT} respectively, two times negative voltage of $V_{DD} - V_{SS}$ output from V_{5OUT} .

• Voltage doubler

By connecting the capacitor between C_2^+ and C_2^- , V_{SS} and V_{5OUT} respectively, and connecting the C_1^+ terminal to C_2^+ terminal, and C_1^- terminal being open, negative voltage of $V_{DD} - V_{SS}$ output from V_{5OUT} .

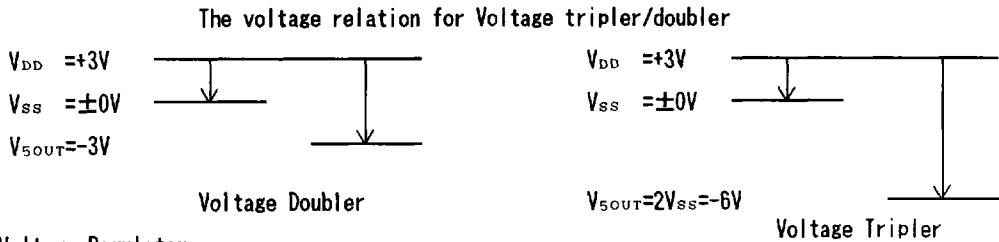

(b) Voltage Regulator

Voltage Regulator incorporates a non-inverting OP-AMP which supplied V_{DD} and V_{5OUT} , and a reference voltage source.

By setting the VR level by connecting R_a and R_b , the regulator which amplifies V_{REF} output the LCD driving voltage to the V_{REG} terminal.

Therefore, the LCD operating voltage can be output between V_{DD} and V_{REG} by setting V_{REF} and the external resistances R_a and R_b .

$$V_{REG} = (1 + R_b/R_a) \cdot V_{REF}$$

$$\text{where, } V_{DD} = 0V \text{ and } |V_{REG}| < |V_{5OUT}|$$

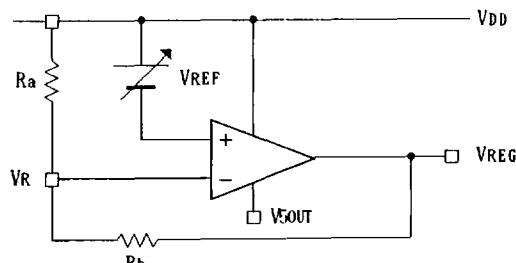

The contrast control function performs V_{REF} value adjustment from 1st step to 16th step by a step setting when the 4-bit data write into the contrast control register by the instruction.

Note : Set the contrast control register to (00)_H when the contrast control function is unused. Use variable resistances to the external resistances R_a , R_b and a thermister if need due to the voltage reference V_{REF} is changed by the lot and operating temperature. Take care the Noise input on the V_R terminal because of it designed in high impedance. Short wiring or sealed wiring are required to avoid the noise input, if necessary.

[The Voltage Reference V_{REF} characteristics]

Supply Voltage : $V_{DD}= 0V$, $V_{SS}= -3V$ Temperature : 25°C

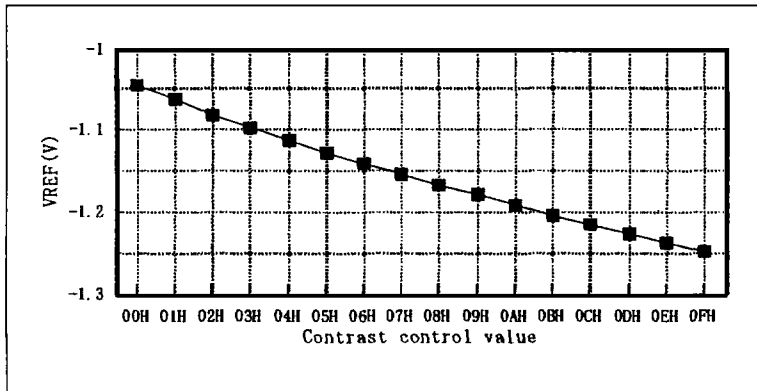

[The LCD Operating Voltage V_{REG} characteristics]

Supply Voltage : $V_{DD}= 0V$, $V_{SS}= -3V$ Voltage Tripler Output : $V_{SOUT}=-9V$
 External Resistances : $R_a = 180k\Omega$, $R_b = 820k\Omega$ Temperature : 25°C

Used Equation : $V_{REG}(XX)_H = (1 + 820k\Omega / 180k\Omega) \cdot V_{REF}(XX)_H$

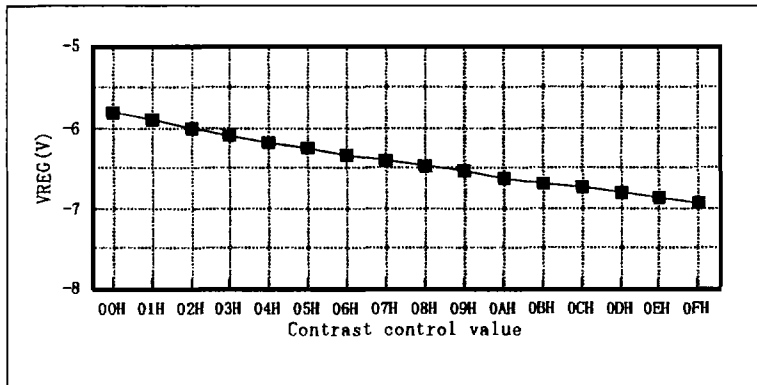

(c) Bleeder Resistance

Each LCD driving voltage (V_1, V_2, V_3, V_4) is generated by the high impedance bleeder resistance buffered by voltage follower OP-AMP to get a enough display characteristics with low operating current.

The bleeder resistance is set 1/6.3 bias suitable for 1/28 duty ratio and $5M\Omega$ resistance in total.

The capacitor connected between V_5 and V_{DD} is needed for stabilizing V_5 . The determination of the each capacitance of C_1, C_2 and C_3 generating for LCD operating voltage, is required to operate with the LCD panel actually. The capacitance for the typical application is shown below :

LCD Driving Voltage vs Duty Ratio

Power supply	Duty Ratio	1/28
	Bias	1/6.3
V_{LCD}		$V_{DD}-V_5$

V_{LCD} is the maximum amplitude for LCD driving voltage.

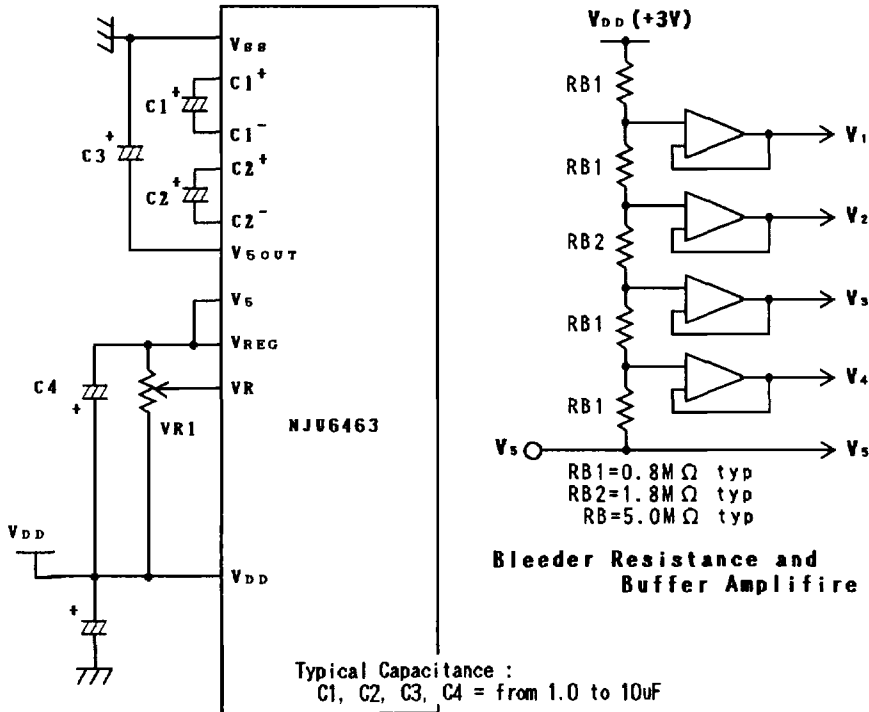

Typical application
for LCD operating voltage generation

Note : Take care the Noise input on the V_R terminal as designed in high impedance. Short wiring or sealed wiring are required to avoid the noise input, if necessary.

(5-2) Relation between oscillation frequency and LCD frame frequency

As the NJU6463 incorporate oscillation capacitor and resistor for CR oscillation, 180kHz oscillation is available without any external components.

The LCD frame frequency example mentioned below is based on 180kHz oscillation.
 (1 clock = 5.56us)

1/28 duty ratio



$$1 \text{ frame} = 5.56(\text{us}) * 82 * 28 = 12.77(\text{ms})$$

$$\text{Frame frequency} = 1 / 12.77(\text{ms}) = 78.3(\text{Hz})$$

(6) Interface with MPU

Interface circuits of NJU6463 can be connected to serial or 4/8-bit parallel. NJU6463 can be interfaced with both of 4/8-bit MPU and the two-time 4-bit or one-time 8-bit data transfer is available.

(6-1) 4-bit MPU interface

When the interface length is 4-bit, the data transfer is performed by 4 lines connected to DB₄ to DB₇ (DB₀ to DB₃ are not used). The data transfer with the MPU is completed by the two-time 4-bit data transfer.

The data transfer is executed in the sequence of upper 4-bit (the data DB₄ to DB₇ at 8-bit length) and lower 4-bit (the data DB₀ to DB₃ at 8-bit length).

The busy flag check can be executed after two-time 4-bit data transfer (1 instruction execution by two-time transfer). In this case, the data of busy flag and address counter contents are also output twice.

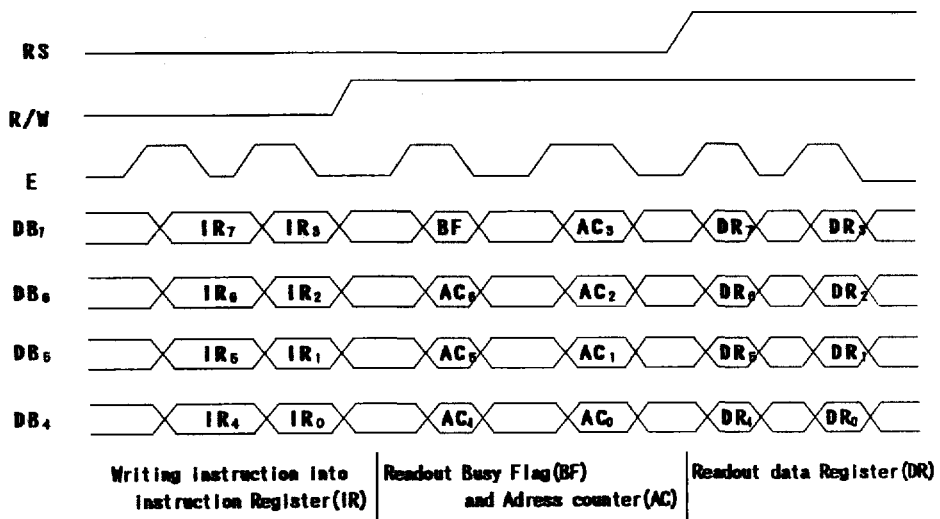
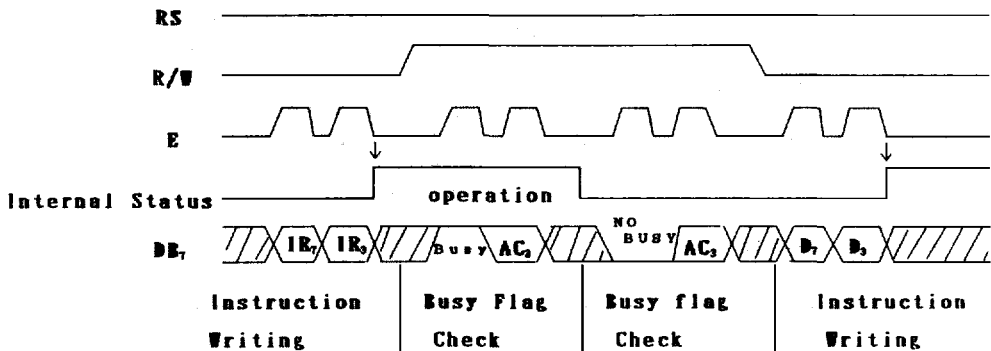

(6-2) 8-bit MPU interface

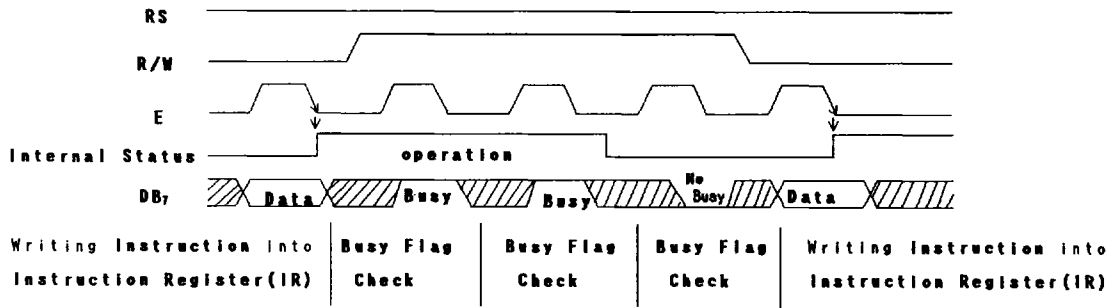

(6-3) Serial interface

Serial interface circuit is activated when the P/S terminal is set to "L" level then the chip select terminal (CS) goes to "L" level. The data input/output is MSB first like as the order of DB₇, DB₆ ... DB₀.

The input data is entered into the shift register synchronized at the rise edge of the serial clock SCL. The shift register converted to parallel data at the CS rise edge input. In case of entering over than 8-bit data, valid data is last 8-bit data.

The output data is exited from the shift register synchronized at the fall edge of the serial clock SCL.

The time chart for the serial interface is shown below.

Note : The level ("L" or "H") of RS and R/W terminals should be set before CS terminal goes to "L" level.

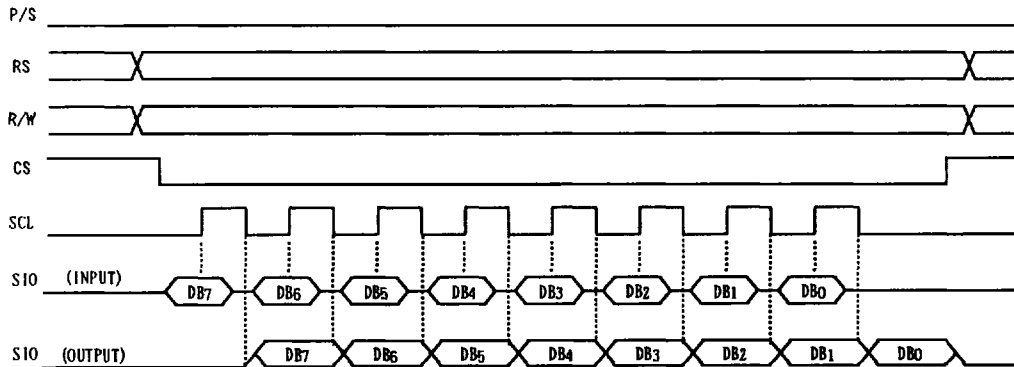

■ ABSOLUTE MAXIMUM RATINGS

 ($T_a=25^{\circ}\text{C}$)

PARAMETER	SYMBOL	RATINGS	UNIT
Supply Voltage	V_{DD}	- 0.3 ~ + 7.0	V
Input Voltage	V_{IN}	- 0.3 ~ $V_{DD}+0.3$	V
Operating Temperature	T_{opr}	- 30 ~ + 80	$^{\circ}\text{C}$
Storage Temperature	T_{stg}	- 55 ~ + 125	$^{\circ}\text{C}$

Note 1) If the LSI are used on condition above the absolute maximum ratings, the LSI may be destroyed. Using the LSI within electrical characteristics is strongly recommended for normal operation. Use beyond the electric characteristics conditions will cause malfunction and poor reliability.

Note 2) Decoupling capacitor should be connected between V_{DD} and V_{SS} due to the stabilized operation for the Voltage converter.

Note 3) All voltage values are specified as $V_{SS} = 0\text{V}$

Note 4) The relation : $V_{DD} > V_{SS}$, $V_{DD} > V_{SS} \geq V_{SOUT}$, $V_{SS} = 0\text{V}$ must be maintained.

■ ELECTRICAL CHARACTERISTICS

 ($V_{DD}=3\text{V} \pm 20\%$, $T_a = -20 \sim +75^{\circ}\text{C}$)

PARAMETER		SYMBOL	CONDITIONS	MIN.	TYP.	MAX.	UNIT	Note
Operating Voltage		V_{DD}		2.4	3.0	3.6	V	
Input Voltage		V_{IH}		$0.8V_{DD}$		V_{DD}	V	5
		V_{IL}				$0.2V_{DD}$	V	5
Output Voltage		V_{OH}	$-I_{OH}=0.205\text{mA}$, $V_{DD}=3\text{V}$	2.0			V	6
		V_{OL}	$I_{OL}=1.6\text{mA}$, $V_{DD}=3\text{V}$			0.5	V	6
Driver On-resist.(COM)		R_{COM}	$\pm I_d=1\mu\text{A}$ (All com term.)			20	$\text{k}\Omega$	9
Driver On-resist.(SEG)		R_{SEG}	$\pm I_d=1\mu\text{A}$ (All seg term.)			30	$\text{k}\Omega$	9
Input Leakage Current		I_{L1}	$V_{IN}=0$ or V_{DD}	-1		1	μA	7
Pull-up MOS Current		$-I_P$	$V_{DD}=3\text{V}$ (All DB terminals)	10	25	50	μA	
Operating Current		I_{DD1}	$V_{DD}=3\text{V}$, $f_{OSC}=\text{Internal Osc.}$ $V_S=-5\text{V}$, during display		T B D		μA	8
		I_{DD2}	$V_{DD}=3\text{V}$, $f_{OSC}=\text{Internal Osc.}$ during access, $t_{CYCE}=5\mu\text{s}$		T B D		μA	8
		I_{DD3}	$V_{DD}=3\text{V}$, $f_{OSC}=\text{Internal Osc.}$ during Powerdown mode		T B D		μA	8
Voltage Converter (Tripler)	Output Voltage	V_{SOUT}	$V_{DD}=3\text{V}$, $I_{OUT}=100\mu\text{A}$, $T_a=25^{\circ}\text{C}$	-4.6	-4.8		V	
	Voltage Efficiency	V_{ef}	$R_L=\infty$	90.0	95.0		%	
Voltage Converter (Doubler)	Output Voltage	V_{SOUT}	$V_{DD}=3\text{V}$, $I_{OUT}=100\mu\text{A}$, $T_a=25^{\circ}\text{C}$		T B D		V	
	Voltage Efficiency	V_{ef}	$R_L=\infty$		T B D		%	
Voltage Regulator	Reference Voltage	V_{REF}	Contrast Control=(00) _H , $T_a=25^{\circ}\text{C}$	TBD	$V_{DD}-1.05$	TBD	V	
	Output Voltage	V_{REG}	$R_L=\infty$, $V_{SOUT}=-6\text{V}$, $T_a=25^{\circ}\text{C}$, $R_a=180\text{k}\Omega$, $R_b=820\text{k}\Omega$, Contrast Control=(00) _H	TBD	$V_{DD}-5.8$	TBD		
Bleeder resistance		R_B	$V_{DD}-V_S=3\text{V}$		5		$\text{M}\Omega$	
Oscillation Frequency		f_{OSC}	$V_{DD}=3\text{V}$, $T_a=25^{\circ}\text{C}$	125	180	235	kHz	
LCD Driving Voltage		V_{LCD}	$V_{LCD}=V_{DD}-V_S$	$V_{DD}-3.0$		$V_{DD}-13.5$	V	10

Note 5) Input/Output structure except LCD driver are shown below:

•Input Terminal Structure

E/SCL, RS, R/W, P/S, SEL, RESET Terminals

TEST Terminal (Pull-Down MOS)

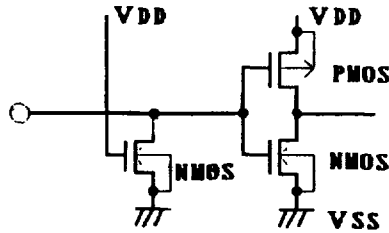
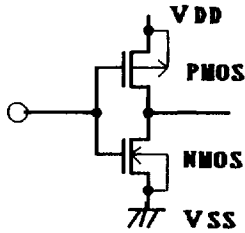

•Input/Output Terminal Structure

DB₀ to DB₇ Terminals

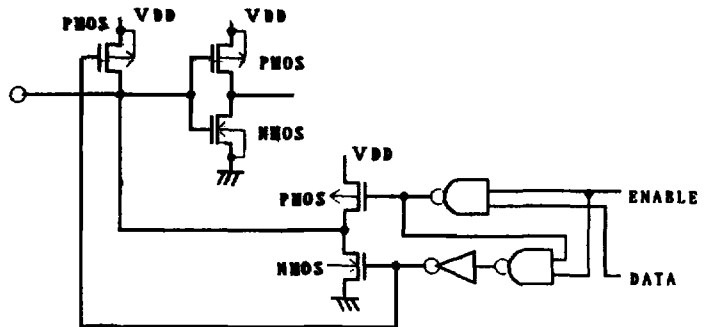

Note 6) Apply to the Output and Input/Output Terminals.

Note 7) Except pull-up resistance current and output driver current.

Note 8) Except Input/output current but including the current flow on bleeder resistance.
If the input level is medium, current consumption will increase due to the penetration current. Therefore, the input level must be fixed to "H" or "L".

Operating Current Measurement Circuit

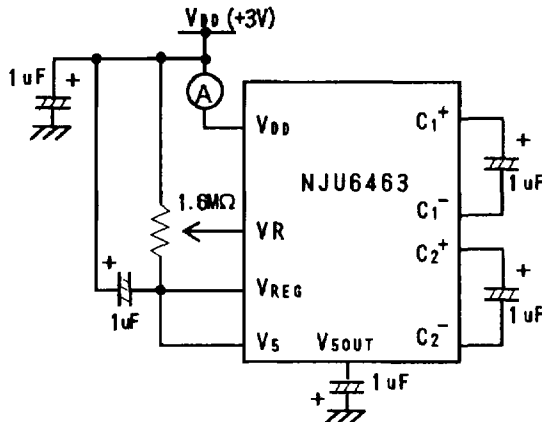

Note 9) R_{COM} and R_{SEG} are the resistance values between power supply terminals (V_{DD} , V_{5OUT}) and each common terminal (COM_1 to COM_{24} , $COMM_1$ to $COMM_4$) and supply voltage (V_{DD} , V_{5OUT}) and each segment terminal (SEG_1 to SEG_{20} , $SEGM_1$ and $SEGM_2$) respectively, and measured when the current I_d is flown on every common and segment terminals at a same time.

Note 10) Apply to the output voltage from each COM and SEG are less than $\pm 0.15V$ against the LCD driving constant voltage (V_{DD} , V_{5OUT}) at no load condition.

Voltage Tripler Measurement Circuit

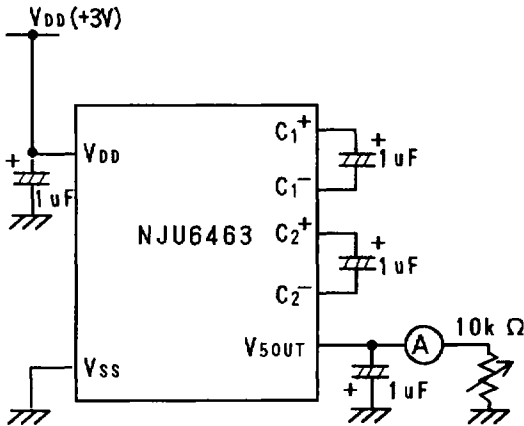

Voltage Doubler Measurement Circuit

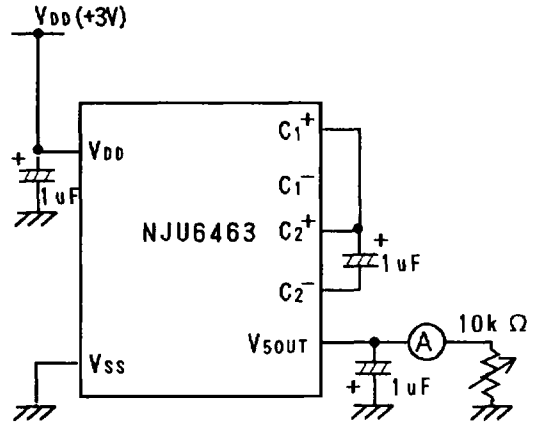

Voltage Tripler/Doubler
Operation Clock Frequency = 10kHz

Bleeder Resistance and Buffer Amplifier

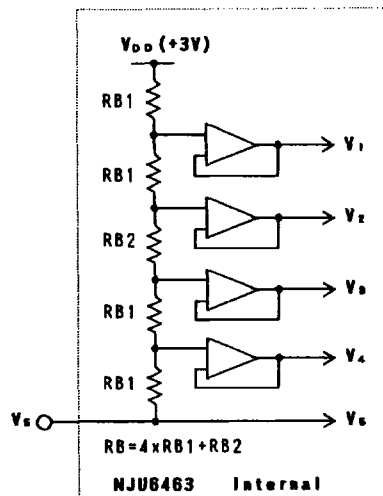

- Bus timing characteristics ($V_{DD} = 3.0V \pm 20\%$, $V_{SS} = 0V$, $T_a = -20 \sim +75^\circ C$)

Write operation (Write from MPU to NJU6463)

PARAMETER	SYMBOL	MIN	MAX	CONDITION	UNIT
Enable cycle time	t_{CYCLE}	1		fig.1	us
Enable pulse width "1" level	P_{WEH}	400			ns
Enable rise time, fall time	t_{Er}, t_{Ef}		20		
Set up time RS, R/W, E	t_{AS}	200			
Address hold time	t_{AH}	200			
Data set up time	t_{DSW}	200			
Data hold Time	t_{H}	200			

Timing Characteristics (Write operation)

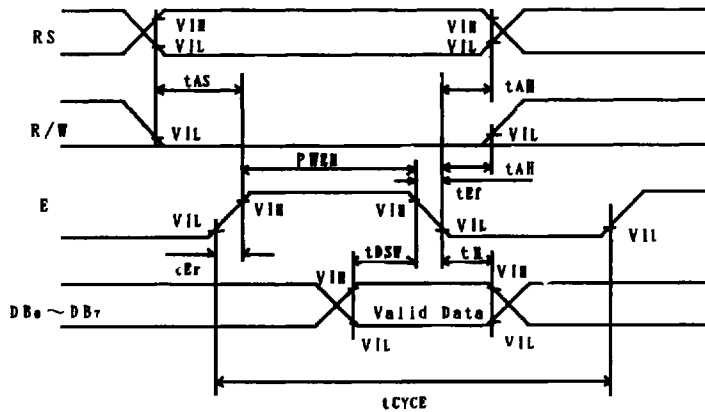

fig. 1

Read operation (Read from NJU6463 to MPU)

PARAMETER	SYMBOL	MIN	MAX	CONDITION	UNIT
Enable cycle time	t_{CVCE}	1		fig.2	us
Enable pulse width "1" level	PW_{EH}	700			ns
Enable rise time, fall time	t_{Er}, t_{Ef}		20		
Set up time RS, R/W, E	t_{AS}	200			
Address hold time	t_{AH}	200			
Data delay time	t_{DDR}		700		
Data hold time	t_{DHR}	200			

 Load Condition of DB0 to DB7 : $CL=100pF$

Timing Characteristics (Read operation)

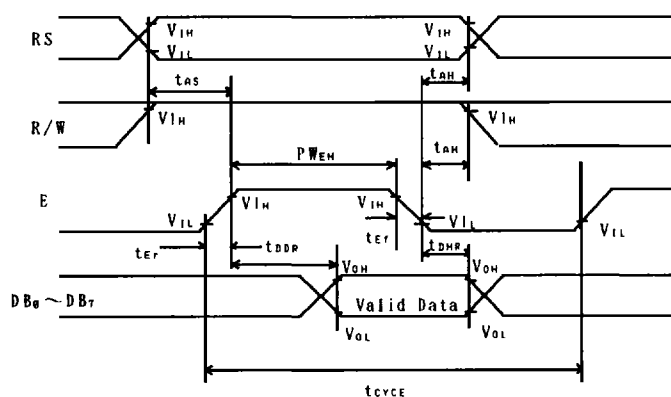

fig. 2

• Serial Interface Sequence

 $(V_{DD} = 3.0V \pm 20\%, V_{SS} = 0V, T_a = -20 \sim +75^\circ C)$

PARAMETER	SYMBOL	MIN	MAX	CONDITION	UNIT
Serial clock cycle time	t_{CYCE}	1		fig.3	μs
Serial clock width	"1" level	t_{SCH}	700		μs
	"0" level	t_{SCL}	300		μs
Serial clock rise and fall Time	t_{SCR}, t_{SCF}		20		μs
Chip select pulse width	PW_{CS}	500			μs
Chip select set up time	t_{CSU}	200			μs
Chip select hold time	t_{CH}	200			μs
Chip Select rise and fall Time	t_{CSR}, t_{CSF}		20		μs
Set up time	RS, R/W - CS	t_{AS}	200		μs
Address hold time	CS - RS, R/W	t_{AH}	200		μs
Serial input data set up time		t_{SISU}	200		μs
Serial input data hold time		t_{SIH}	200		μs
Serial output data delay time			700		μs
Serial output data hold time		t_{SOH}	200	μs	

Serial Interface

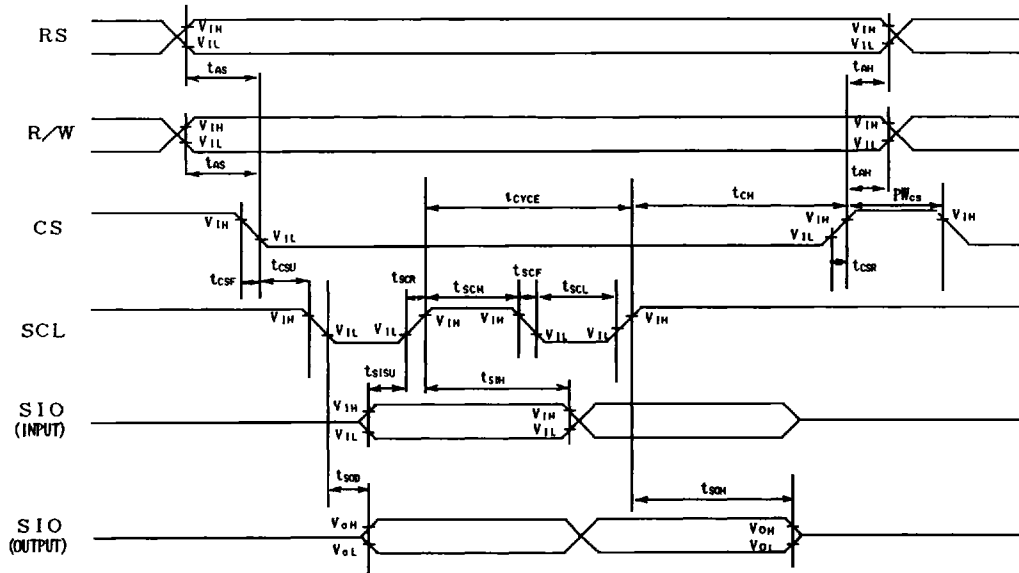
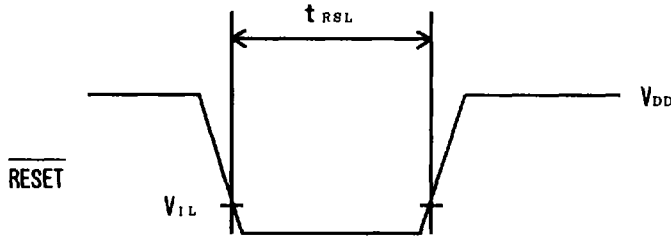

fig. 3

• The Input Condition when using the Hardware Reset Circuit

Input timing



PARAMETER	SYMBOL	CONDITION	MIN	MAX	UNIT
Reset input "0" level width	t_{RSL}	$f_{OSC}=180kHz$	1.2	-	ms

• Power Supply Condition when using the internal initialization circuit ($T_a = -20 \sim +75^{\circ}C$)

PARAMETER	SYMBOL	CONDITION	MIN	MAX	UNIT
Power supply rise time	t_{rDD}		0.1	5	ms
Power supply OFF time	t_{OFF}		1		

Since the internal initialization circuits will not operate normally unless the above conditions are met, in such a case initialize by instruction.
(Refer to initialization by the instruction)

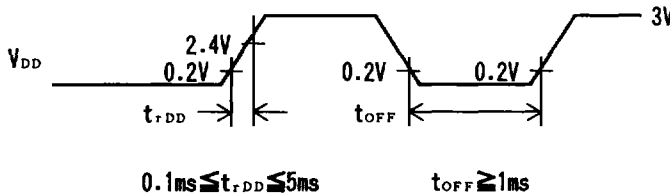

t_{OFF} specifies the power off time in a short period off or cyclical on/off.

■ LCD DRIVING WAVE FORM

1/28 Duty Driving

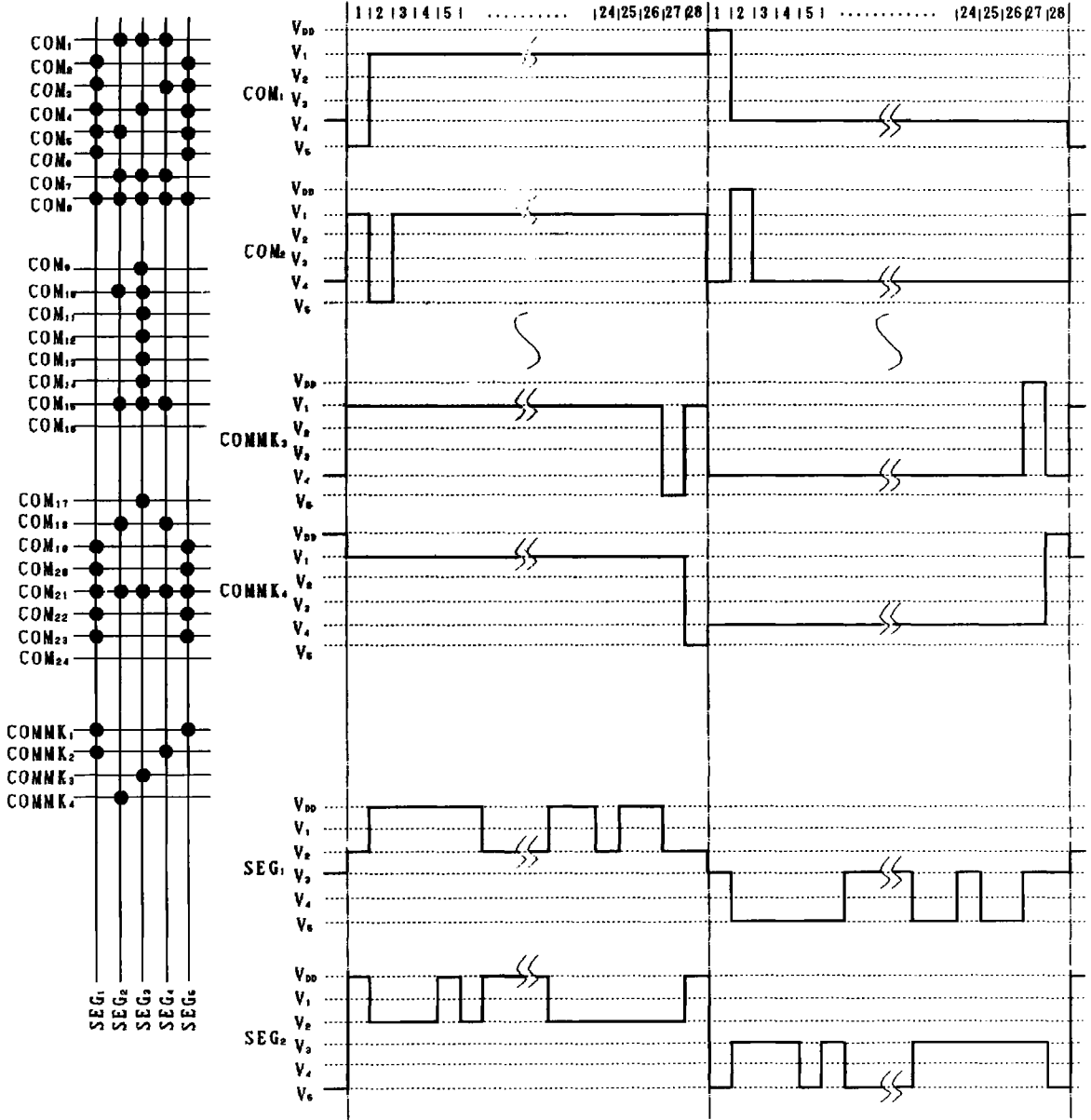

■ APPLICATION CIRCUITS (1)

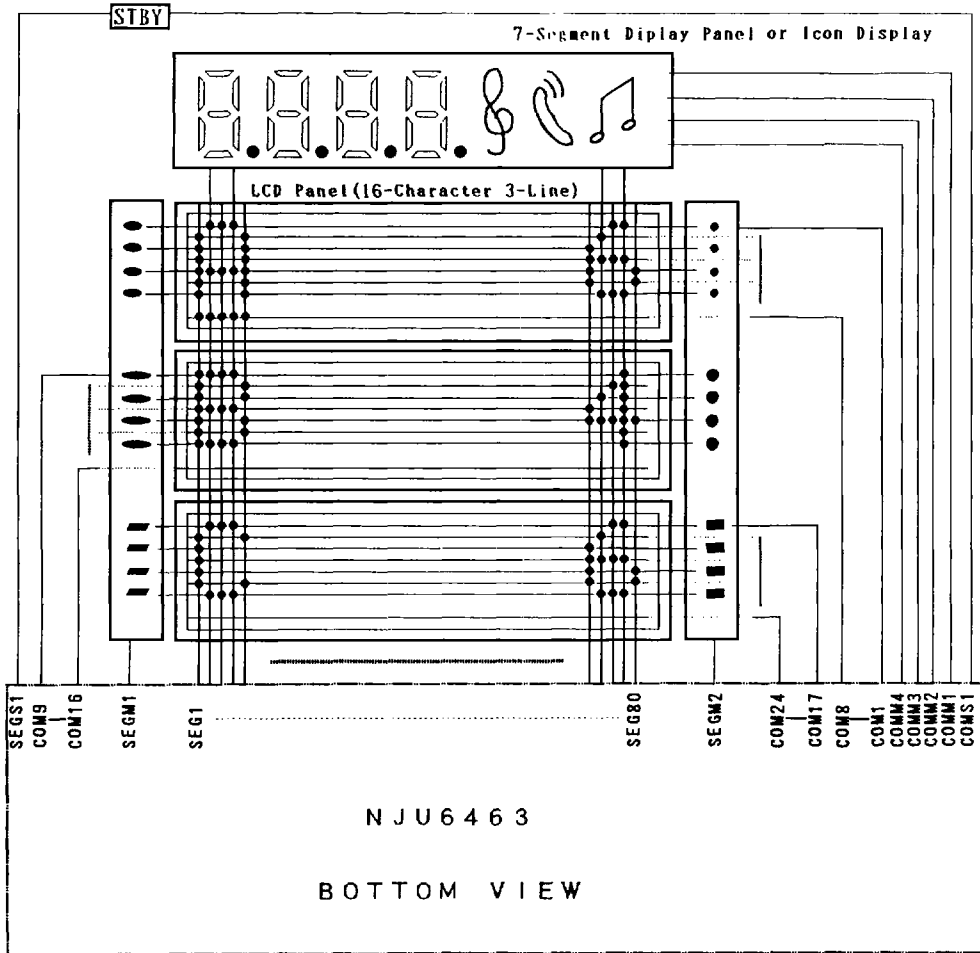

16-character 3-line Display Example
 (The terminal description is "Mode A".)

■ APPLICATION CIRCUITS (2)

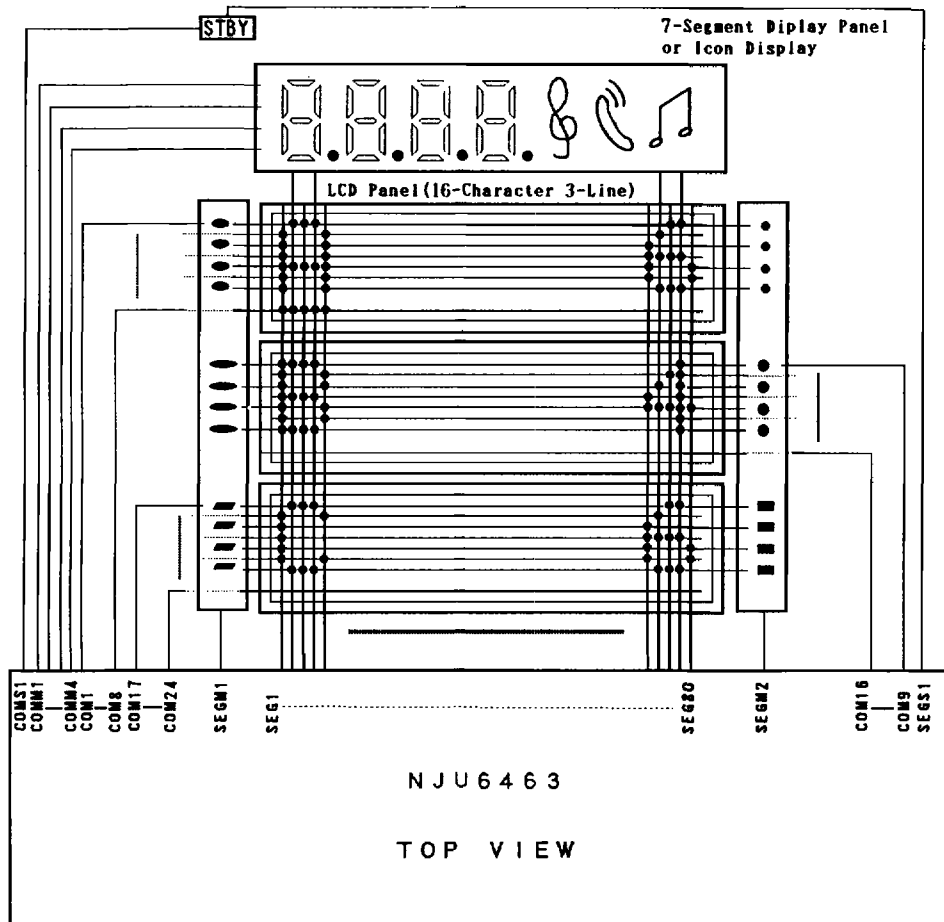

16-character 3-line Display Example
(The terminal description is "Mode B".)