

MITSUBISHI ELEK (LINEAR)

PICTURE-IN-PICTURE SOUND SWITCHING

**DESCRIPTION**

The M51659L is packed in a 24-pin plastic zigzag in-line package. With use of this circuit, the VCR stereo sound processing circuit becomes smaller, because it has a built-in picture-in-picture sound switching circuit and AGC circuit, both in two channels, and does not need many external parts.

**FEATURES**

- Picture-in-picture sound switch
- Built-in AGC circuit
- Stereo (2-channel) construction

**APPLICATIONS**

Video cassette recorders and Hi-Fi video cassette recorders

**RECOMMENDED OPERATING CONDITIONS**

Rated supply voltage .....  $V_{CC}+5V, V_{EE}-6V$   
 Supply voltage .....  $V_{CC}+4.5\sim 5.5V, V_{EE}-6.5\sim -5.5V$

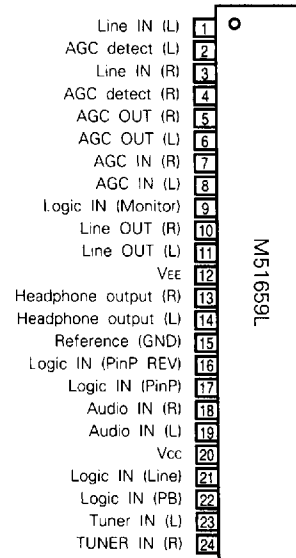
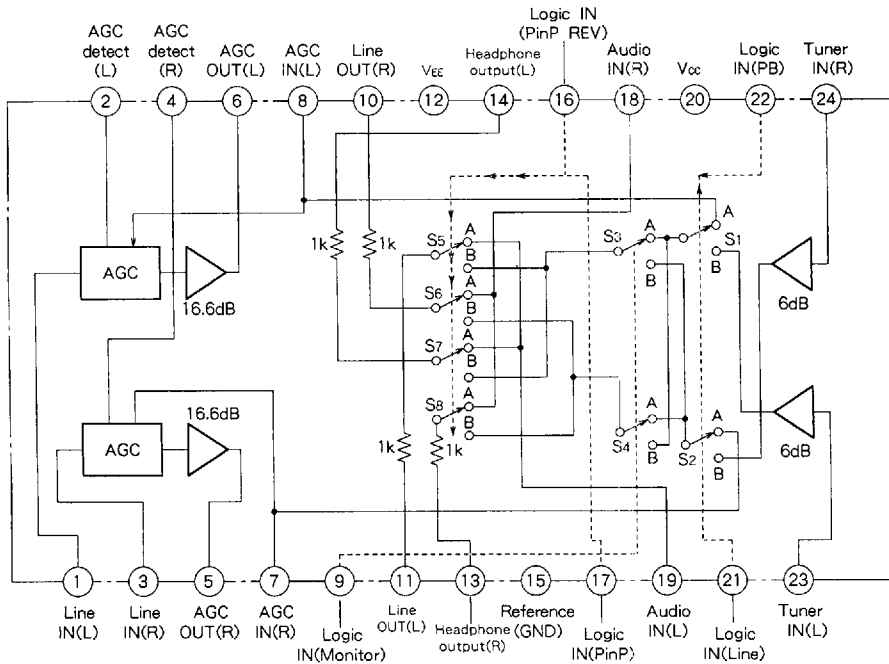
**PIN CONFIGURATION (TOP VIEW)****BLOCK DIAGRAM**

## MITSUBISHI ELEK (LINEAR)

M51659L

## PICTURE-IN-PICTURE SOUND SWITCHING

## ABSOLUTE MAXIMUM RATINGS

Symbol	Parameter	Ratings	Unit
V <sub>CC</sub>	Supply voltage	+7	V
V <sub>EE</sub>		-7	V
I <sub>CC</sub>	Circuit current	60	mA
I <sub>EE</sub>		60	mA
P <sub>d</sub>		800	mW
K <sub>θ</sub>	Thermal derating	8	mW/°C
T <sub>opr</sub>	Operating temperature	-20~75	°C
T <sub>stg</sub>	Storage temperature	-40~125	°C

ELECTRICAL CHARACTERISTICS (T<sub>a</sub> = 25°C, unless otherwise noted)

Symbol	Parameter	Test conditions	Limits			Unit
			Min.	Typ.	Max.	
I <sub>CC</sub>	PB mode no - signal circuit current	No signal	-9.0	15.5	22.0	mA
I <sub>EE</sub>	PB mode no - signal circuit current	No signal	8.5	14.5	20.5	mA
V <sub>OLA</sub>	Line system output signal level	V <sub>in</sub> = -23dBs	-10.0	-8.0	-6.0	dBs
THDL	Line system distortion rate	V <sub>in</sub> = -23dBs, 400Hz HPF, 30kHz LPF	*	0.2	0.6	%
NOL	Line system output noise	R <sub>g</sub> = 2kΩ, BW = 20Hz~20kHz	*	-85	-79	dBs
V <sub>OT</sub>	Tuner system output signal level	V <sub>in</sub> = -14dBs	-11.1	-9.6	-8.1	dBs
THDT	Tuner system distortion rate	V <sub>in</sub> = -14dBs, 400Hz HPF, 30kHz LPF	*	0.05	0.2	%
NOT	Tuner system output noise	R <sub>g</sub> = 2kΩ, BW = 20Hz~20kHz	*	-90	-84	dBs
V <sub>OA</sub>	AUD system output signal level	V <sub>in</sub> = -4.8dBs	-7.4	-6.4	-5.4	dBs
THDA	AUD system distortion rate	V <sub>in</sub> = -4.8dBs, 400Hz HPF, 30kHz LPF	*	0.05	0.1	%
NOA	AUD system output noise	R <sub>g</sub> = 2kΩ, BW = 20Hz~20kHz	*	-90	-84	dBs
V <sub>TH1</sub>	Input threshold voltage 1	Voltage applied when mode is switched.	0.9	1.4	1.9	V
V <sub>TH2</sub>	Input threshold voltage 2	Voltage applied when monitor is switched from L to M.	0.8	1.2	1.6	V
V <sub>TH3</sub>	Input threshold voltage 3	Voltage applied when monitor is switched from M to H.	3.5	3.9	4.3	V

## ELECTRICAL CHARACTERISTICS TEST METHOD

Symbol	⑨ Monitor	⑮ PinP REV	⑰ PinP	⑳ PinP S.C	㉑ PB	SW <sub>1</sub>	SW <sub>2</sub> SW <sub>3</sub>	SW <sub>4</sub> SW <sub>5</sub>	SW <sub>6</sub> SW <sub>7</sub>	Measuring procedure	Note
I <sub>CC</sub>	L	H	H	H	H	OFF	2	2	2	Read the no-signal circuit current with the ammeter during PB.	
I <sub>EE</sub>	L	H	H	H	H	OFF	2	2	2	Read the no-signal circuit current with the ammeter during PB.	6
V <sub>OLA</sub>	L	H L	H	H	H	ON	1	2	2	Measure output signal level during line input.	6
THDL	L	H L	H	H	H	ON	1	2	2	Measure output distortion rate during line input.	6
NOL	L	H L	H	H	H	ON	2	2	2	BW = 20Hz~20kHz	6
V <sub>OT</sub>	L	H L	H	L	H	ON	2	1	2	Measure output signal level during tuner input.	6
THDT	L	H L	H	L	H	ON	2	1	2	Measure output distortion rate during tuner input.	6
NOT	L	H L	H	L	H	ON	2	2	2	BW = 20Hz~20kHz	
V <sub>OA</sub>	L	L	L	H	H	ON	2	2	1	Measure output signal level during AUD input.	
THDA	L	L	L	H	H	ON	2	2	1	Measure output distortion rate during AUD input.	
NOA	L	L	L	H	H	ON	2	2	2	BW = 20Hz~20kHz	

Note: 5 H, 5V; L, 0V.

: 6 Pin ⑨ PinP REV "H," line out; "L," H.P. out.

MODE SWITCH TRUTH VALUE TABLE

⑰ Line,S.C	⑱ PB	S <sub>1</sub>	S <sub>2</sub>	Remark
L	L	A	A	Line
L	H	B	B	Tuner
H	L	A	A	Line
H	H	A	A	Line

⑲ Monitor	S <sub>3</sub>	S <sub>4</sub>	Remark
L	A	A	Stereo
M	A	B	Lch
H	B	A	Rch

⑳ PinP REV	㉑ PinP	S <sub>5</sub>	S <sub>6</sub>	S <sub>7</sub>	S <sub>8</sub>	Remark
L	L	A	A	A	A	Normal
L	H	A	A	B	B	PinP
H	L	A	A	A	A	Normal
H	H	B	B	B	A	PinP REV

Note 7. H: 5V  
M: 2.5V  
L: 0V

TEST CIRCUIT

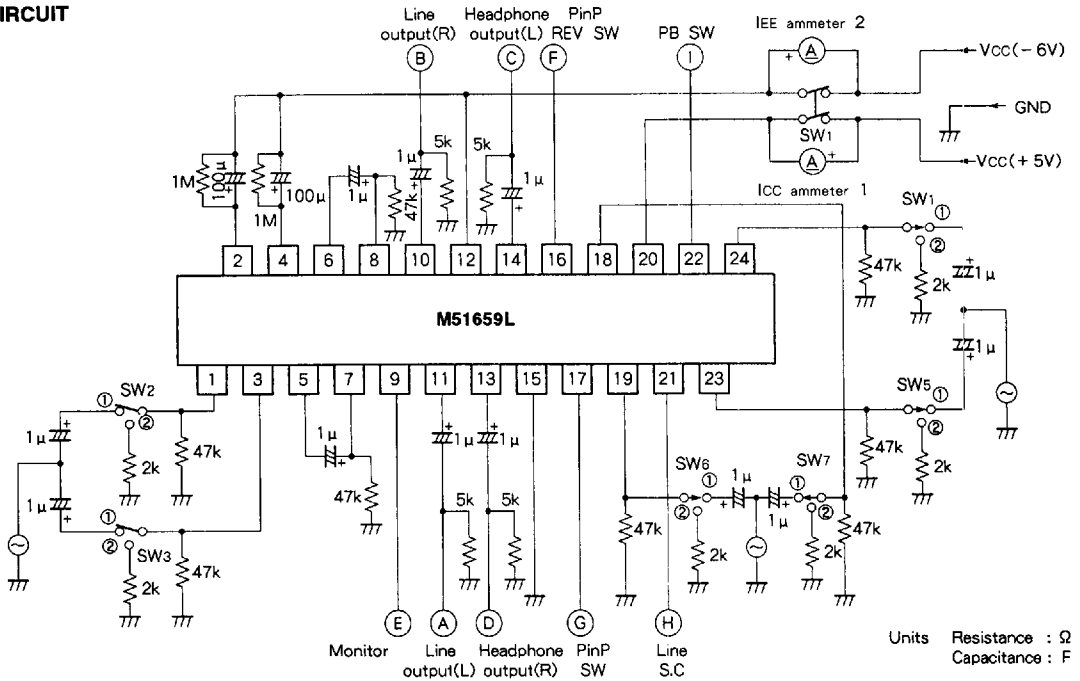

PICTURE-IN-PICTURE SOUND SWITCHING

TYPICAL CHARACTERISTICS (Ta = 25°C, unless otherwise noted)

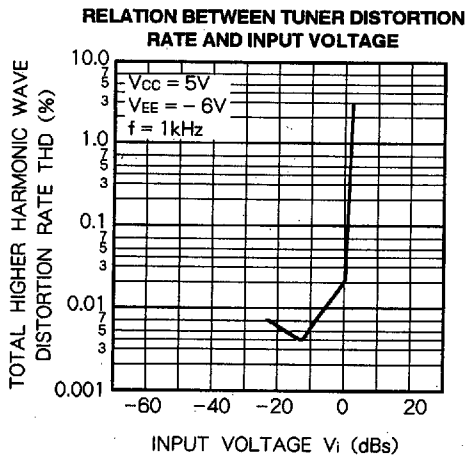
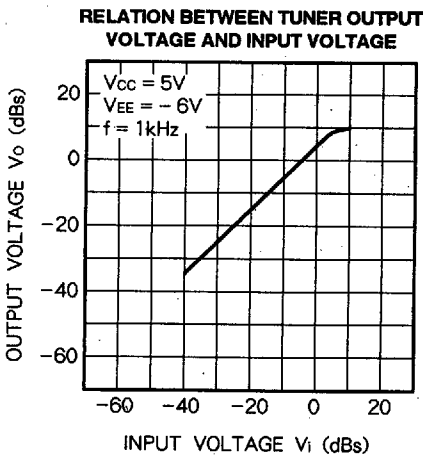
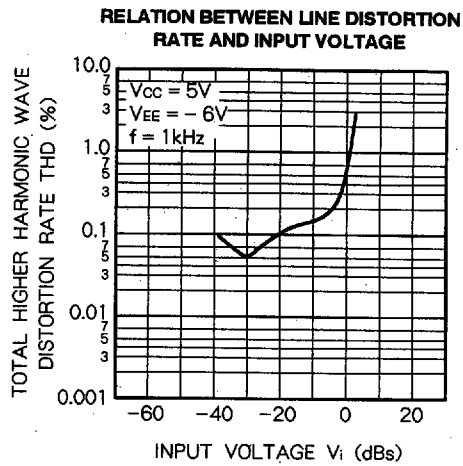
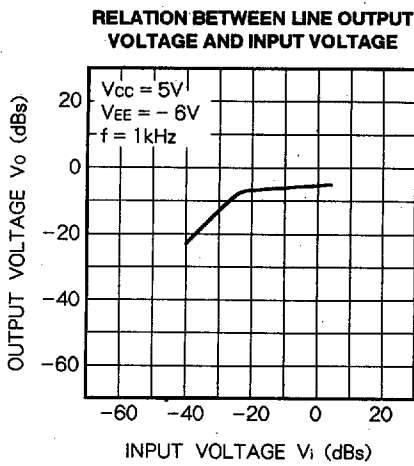
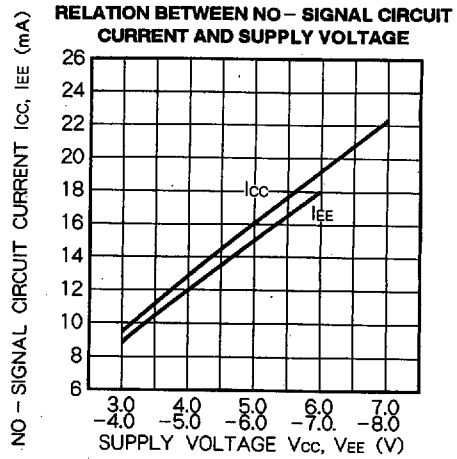
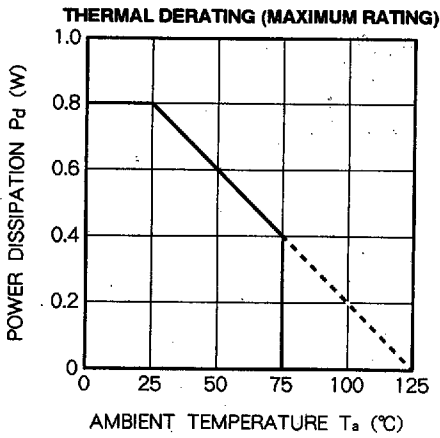

MITSUBISHI ELEK (LINEAR)

PICTURE-IN-PICTURE SOUND SWITCHING

RELATION BETWEEN AUD OUTPUT VOLTAGE AND INPUT VOLTAGE

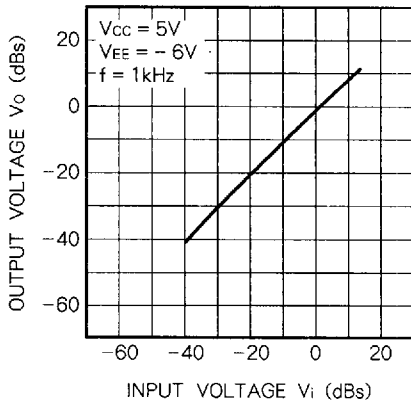

RELATION BETWEEN AUD DISTORTION RATE AND INPUT VOLTAGE

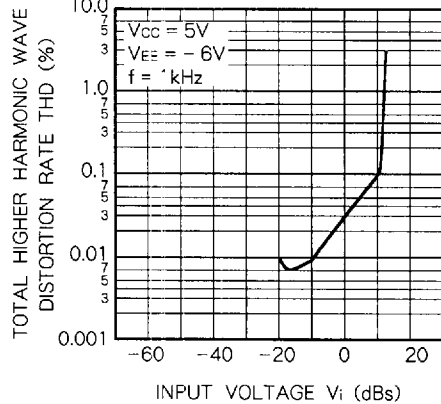

APPLICATION EXAMPLE

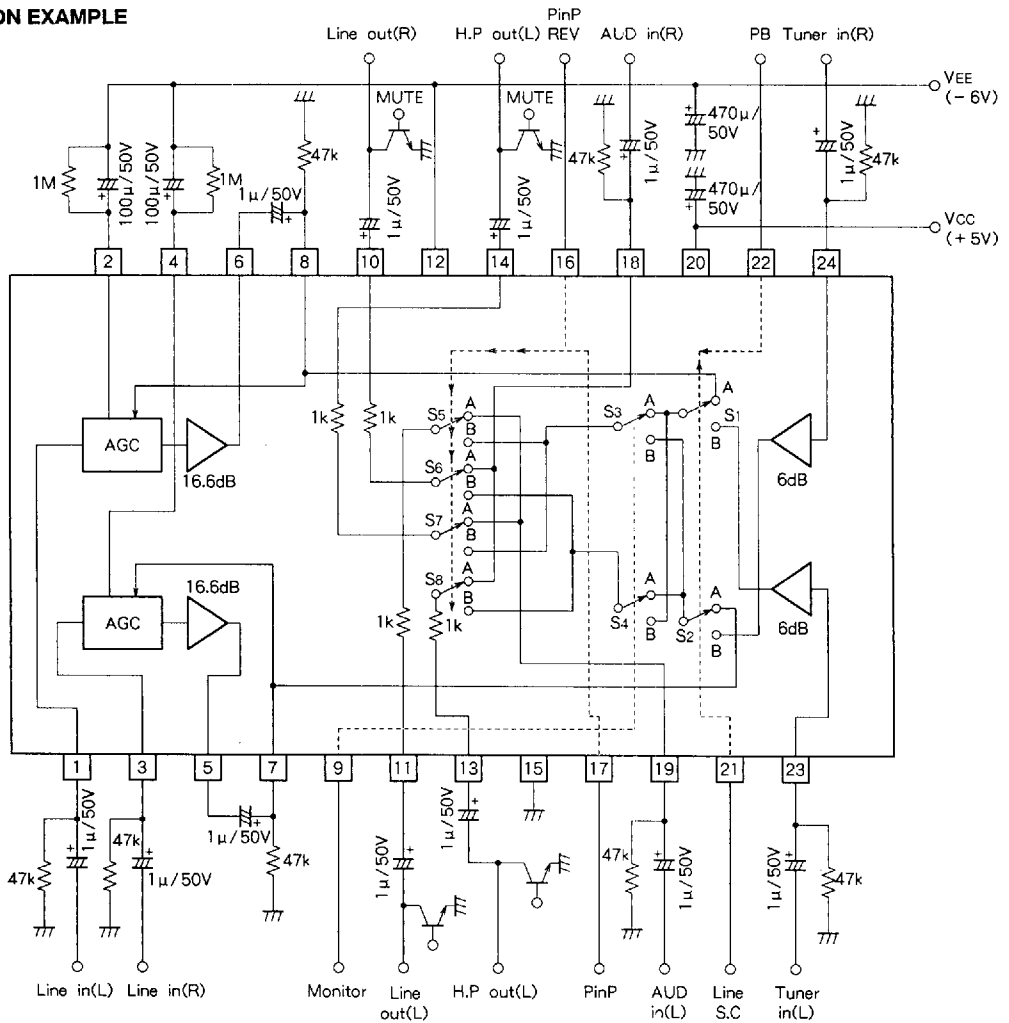

Units Resistance :  $\Omega$   
Capacitance : F

## MITSUBISHI ELEK (LINEAR)

## PICTURE-IN-PICTURE SOUND SWITCHING

## DESCRIPTION OF PIN

Pin No.	Name	Description
①	Line in(L)	Line input pin(L)
②	AGC detection(L)	AGC rectified current voltage pin(Lch)
③	Line in(R)	Line input pin(Rch)
④	AGC detection(R)	AGC rectified current voltage pin(Rch)
⑤	AGC OUT(R)	AGC Amp output pin(Rch)
⑥	AGC OUT(L)	AGC Amp output pin(Lch)
⑦	AGC OUT in(R)	AGC Amp output signal input pin(Rch)
⑧	AGC OUT in(L)	AGC Amp output signal input pin(Lch)
⑨	Monitor	Logic input pin
⑩	Line out(R)	Line output pin(Rch)
⑪	Line out(L)	Line output pin(Lch)
⑫	VEE	Negative supply voltage pin
⑬	H.P out(R)	Headphone output pin(Rch)
⑭	H.P out(L)	Headphone output pin(Lch)
⑮	Vref	Reference pin
⑯	PinP REV	Logic input pin
⑰	PinP	Logic input pin
⑱	AUD in(R)	Audio input pin(Rch)
⑲	AUD in(L)	Audio input pin(Lch)
⑳	Vcc	Positive supply voltage pin
㉑	Line, S.C	Logic input pin
㉒	PB	Logic input pin
㉓	Tuner in(L)	Tuner input pin(Lch)
㉔	Tuner in(R)	Tuner input pin(Rch)