

3.3V 256Kx32 CMOS synchronous graphic RAM

Features

- Organization
  - 131,072 words x 32 bits x 2 banks
- Fully synchronous
  - All signals referenced to positive edge of clock
- Internal pipeline operation
  - Column address can be changed every clock cycle
- Two internal banks controlled by BA (bank select)
- High speed
  - 150/133/100 MHz
  - 6.5/7/9 ns clock access time
- 1024 refresh cycles, 16 ms refresh interval (Auto or Self)
- Auto precharge and Auto refresh modes
- Two color registers
  - Burst read, single write operation
  - LVTTTL compatible I/O
  - 3.3V power supply
  - JEDEC standard package, pinout and function
  - 100-pin PQFP
  - Read/write data masking
  - Programmable burst length (1/2/4/8/full page)
  - Programmable burst sequence (sequential/interleaved)
  - Programmable CAS latency (1/2/3)
  - Graphics features
    - SMRS cycle
    - Block write (8 columns), write per bit

Pin arrangement

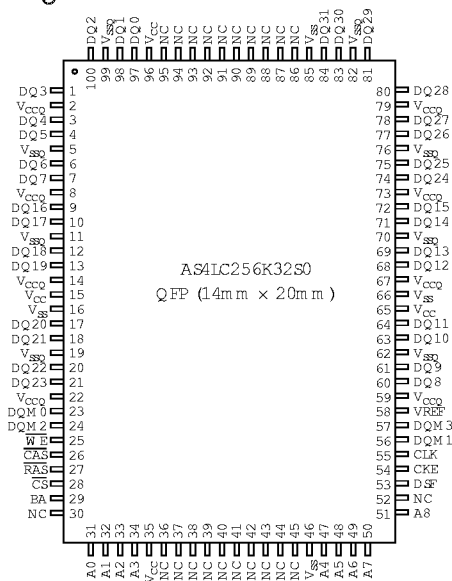

Pin designation

Pin (s)	Description
DQM 0 to DQM 3	Output disable/w rite mask
A0 to A8	Address inputs
BA	Bank select input
DQ 0 to DQ 31	Input/output
$\overline{\text{RAS}}$	Row address strobe
$\overline{\text{CAS}}$	Column address strobe
$\overline{\text{WE}}$	Write enable
$\overline{\text{CS}}$	Chip select
$V_{CC}, V_{CCQ}$	Power (3.3V $\pm$ 0.3V)
$V_{SS}, V_{SSQ}$	Ground
CLK	Clock input
CKE	Clock enable
DSF	Special function enable
VREF	SSTL reference voltage input

SGRAM

Selection guide

	Symbol	-150	-133	-100	Unit
Bus frequency	$f_{m \max}$	150	133	100	MHz
Maximum clock access time	$t_{AC}$	6.5	7	9	ns
Minimum address setup time	$t_{AS}$	2	2.5	2.5	ns
Minimum address hold time	$t_{AH}$	1.5	1.5	1.5	ns
Minimum row cycle time	$t_{RC}$	60	67.5	78	ns
Maximum operating current	$I_{CC1}$	300	275	185	mA
Maximum CMOS standby current, self refresh	$I_{CC6}$	3	3	3	mA



## Functional description

The AS4LC256K32S0 is a high performance 8 megabit CMOS Synchronous Graphics Random Access Memory (SGRAM) organized as 131,072 words  $\times$  32 bits  $\times$  2 banks. Very high bandwidth is achieved using a pipelined architecture where all inputs and outputs are referenced to the rising edge of a common clock. Programmable burst mode can be used to read up to a full page of data without selecting a new column address.

The two internal banks can be alternately accessed (read or write) at the maximum clock frequency for seamless interleaving operations. This provides a significant advantage over asynchronous EDO and fast page mode devices.

This SGRAM product also features a programmable mode register, allowing users to select read latency as well as burst length and type (sequential or interleaved). Lower latency improves first data access in terms of CLK cycles, while higher latency improves maximum frequency of operation. This feature enables flexible performance optimization for a variety of applications.

DRAM commands and functions are decoded from control inputs. Basic commands are as follows:

- Mode register set
- Select column, write
- Auto precharge with read/write
- Special mode register set
- De-activate bank
- Select column, read
- Self refresh
- Deactivate all banks
- Deselect, power down
- Block write
- Select row, activate bank
- CBR refresh
- Write per bit

The 8 Mb SGRAM device is available in a 100-pin PQFP. It operates with a power supply of  $3.3V \pm 0.3V$ . Multiple power and ground pins are provided for low switching noise and EMI. Inputs and outputs are I<sup>2</sup>TTL compatible.

## Logic block diagram

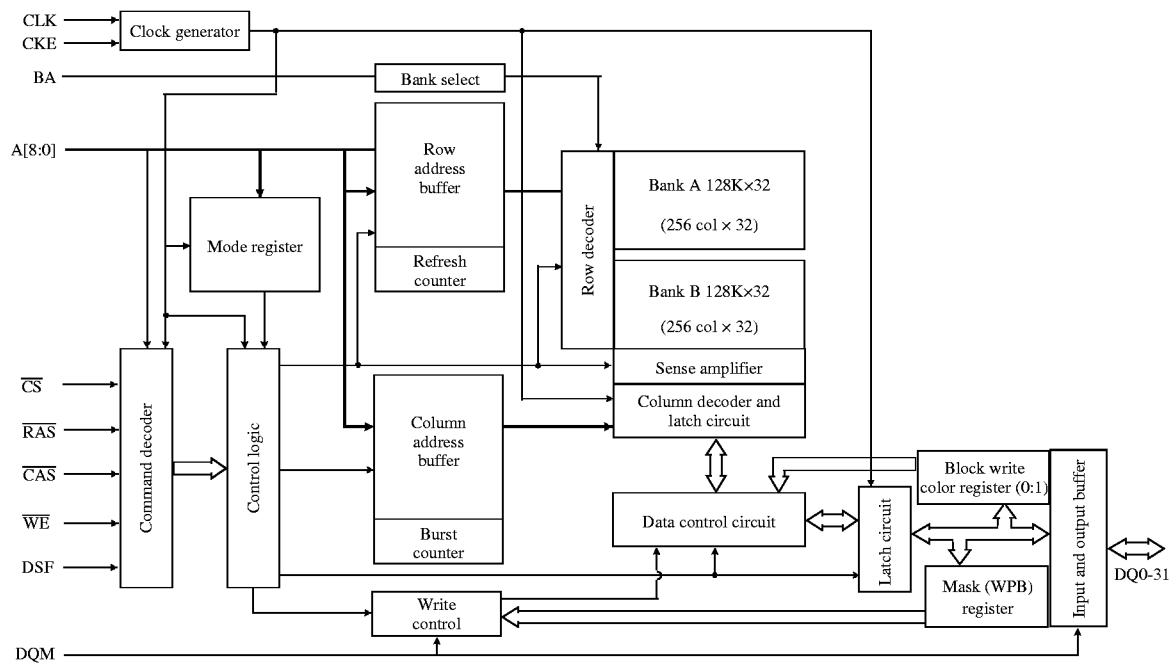

SGRAM



### Recommended operating conditions

Parameter	Symbol	Min	Nominal	Max	Unit
Supply voltage	$V_{CC}, V_{CCQ}$	3.0	3.3	3.6	V
	GND	0.0	0.0	0.0	V
Input voltage	$V_{IH}$	2.0	-	$V_{CC} + 0.3$	V
	$V_{IL}$	-0.5 <sup>†</sup>	-	0.8	V
Output voltage <sup>‡</sup>	$V_{OH}$	2.4	-	-	V
	$V_{OL}$	-	-	0.4	V
Ambient operating temperature	$T_A$	0		70	°C

<sup>†</sup> $V_{IL}$  min = -1.5V for pulse widths less than 5 ns.

<sup>‡</sup> $I_{OH}$  = -2mA, and  $I_{OL}$  = 2mA

Recommended operating conditions apply throughout this document unless otherwise specified.

### Absolute maximum ratings

Parameter	Symbol	Min	Max	Unit
Input voltage	$V_{in}, V_{out}$	-1.0	+4.6	V
Power supply voltage	$V_{CC}, V_{CCQ}$	-1.0	+4.6	V
Storage temperature (plastic)	$T_{SIG}$	-55	+150	°C
Power dissipation	$P_D$	-	1	W
Short circuit output current	$I_{out}$	-	50	mA

Stresses greater than those listed under **Absolute Maximum Ratings** may cause permanent damage to the device. This is a stress rating only and functional operation of the device at these or any other conditions outside those indicated in the operational sections of this specification is not implied. Exposure to absolute maximum rating conditions for extended periods may affect reliability.



## DC electrical characteristics

Parameter	Symbol	Test conditions	-150		-133		-100		Unit	Notes	
			Min	Max	Min	Max	Min	Max			
Input leakage current	$I_{IL}$	$0V \leq V_{in} \leq V_{CC}$ , Pins not under test = 0V	-3	+3	-3	+3	-3	+3	$\mu A$		
Output leakage current	$I_{OL}$	$D_{OUT}$ disabled, $0V \leq V_{OUT} \leq V_{CCQ}$	-3	+3	-3	+3	-3	+3	$\mu A$		
Operating current (one bank active)	$I_{CC1}$	$t_{RC} \geq t_{min}$ , $I_{DL} = 0m A$ , burst length = 1	CL = 3	-	300	-	275	-	185	mA	1
			CL = 2	-	275	-	250	-	175		
Precharge standby current (power down mode)	$I_{CC2P}$	$CKE \leq V_{IL}$ (max), $t_{CK} = 15 ns$	-	3	-	3	-	3	mA		
	$I_{CC2PS}$	$CKE \& CLK \leq V_{IL}$ (max), $t_{CK} = \infty$	-	3	-	3	-	3			
Precharge standby current (non power down mode)	$I_{CC2N}$	$CS \geq V_{IH}$ (min), $CKE \geq V_{IH}$ (min), $t_{CC} = 15 ns$ ; input signals changed once during 30 ns	-	45	-	45	-	45	mA		
	$I_{CC2NS}$	$CLK \leq V_{IL}$ (max), $CKE \geq V_{IH}$ (min), $t_{CK} = \infty$ ; input signals stable	-	20	-	20	-	20			
Active standby current (power down mode)	$I_{CC3P}$	$CKE \leq V_{IL}$ (max), $t_{CK} = 15 ns$	-	3	-	3	-	3	mA		
	$I_{CC3PS}$	$CLK, CKE \leq V_{IL}$ (max), $t_{CK} = \infty$	-	3	-	3	-	3			
Active standby current (non power down mode, one bank active)	$I_{CC3N}$	$CKE \geq V_{IH}$ (min), $CS \geq V_{IH}$ (min), $t_{CK} = 15 ns$ ; input signals changed once during 30 ns	-	50	-	50	-	50	mA		
	$I_{CC3NS}$	$CKE \geq V_{IH}$ (min), $CLK \geq V_{IL}$ (max), $t_{CK} = \infty$ ; input signals stable	-	25	-	25	-	25			
Operating current (burst mode)	$I_{CC4}$	$I_{OL} = 0m A$ , Page burst, All banks activated $t_{CCD} = t_{CCD}$ (min)	CL = 3	-	225	-	200	-	190	mA	1,2
			CL = 2	-	175	-	150	-	140		
Refresh current	$I_{CC5}$	$t_{RC} \geq t_{RC}$ (min)	CL = 3	-	180	-	150	-	150	mA	3
			CL = 2	-	150	-	130	-	130		
Self refresh current	$I_{CC6}$	$CKE \leq 0.2 V$	-	3	-	3	-	3	mA		

\* CL = CAS latency

1 This parameter depends on output loading and cycle rates. Measured with outputs open, inputs only change one time during  $t_{CK}$  (min).2 Assumed  $t_{CCD}$  (min)

3 Refresh period = 16ms



## AC parameters common to all waveforms

Symbol	Parameter	CAS latency	-150		-133		-100		Unit	Notes
			Min	Max	Min	Max	Min	Max		
$t_{RRD}$	Row active to row active delay		6.5	-	7.5	-	10	-	ns	1
$t_{RCD}$	$\overline{RAS}$ to $\overline{CAS}$ delay time		20	-	22.5	-	30	-	ns	1
$t_{RP}$	Row precharge		20	-	22.5	-	30	-	ns	1
$t_{RAS}$	Row active		40	120K	45	120K	60	120K	ns	1
$t_{RC}$	Row cycle time		60	-	67.5	-	90	-	ns	1
$t_{CDL}$	Last data in to new column address delay		1	-	1	-	1	-	CLK	2
$t_{RDL}$	Last data in to row precharge		1	-	1	-	1	-	CLK	2
$t_{BDL}$	Last data in to burst stop		1	-	1	-	1	-	CLK	2
$t_{CCD}$	Column address to column address delay		1	-	1	-	1	-	CLK	3
$t_{CK}$	CLK cycle time	3	6.7	-	7.5	-	10	-	ns	4
		2	10	-	12	-	15	1000		4
$t_{AC}$	CLK to valid output delay	3	-	6.5	-	7.0	-	9.0	ns	4,5
		2	-	7.5	-	10	-	12		4,5
$t_{OH}$	Output data hold time		3.5	-	3.5	-	3.5	-	ns	
$t_{CH}$	CLK high pulse width		3.0	-	3.0	-	3.5	-	ns	6
$t_{CL}$	CLK low pulse width		2.5	-	3.0	-	3.5	-	ns	6
$t_S$	Input setup time		2.0	-	2.5	-	2.5	-	ns	6
$t_H$	Input hold time		1.5	-	1.5	-	1.5	-	ns	6
$t_{SLZ}$	CLK to output in low Z		3	-	3	-	3	-	ns	5
$t_{SHZ}$	CLK to output in high Z		3.5	6.7	3.5	7.5	3.5	10	ns	

- 1 Minimum clock cycles = (Minimum time / clock cycle time) rounded up
- 2 Minimum delay required to complete write.
- 3 Column address change allowed every cycle.
- 4 Parameters dependent on CAS latency.
- 5 If clock rising time > 1ns,  $(tr/2-0.5)$ ns should be added to parameter.
- 6 If  $(tr$  and  $tf)$  > 1ns,  $[(tr+tf)/2-1]$ ns should be added to parameter.



## Operating modes

Command		CKE <sub>n-1</sub>	CKE <sub>n</sub>	$\overline{CS}$	$\overline{RAS}$	$\overline{CAS}$	$\overline{WE}$	DSF	DQM	BA	A8	A7-A0	Note
Mode register set		H	X	L	L	L	L	L	X			Op code	1,2
Special mode register set		H	X	L	L	L	L	H	X			Op code	
Auto refresh		H	H	L	L	L	H	X	X	X	X	X	3
Self refresh	Entry	H	L	L	L	L	H	X	X	X	X	X	3
	Exit	L	H	L	H	H	H	X	X	X	X	X	3
Bank activate		H	X	L	L	H	H	L	X	V		row address	
	w / W PB							H	X	V			
Read	Auto precharge disable	H	X	L	H	L	H	X	X	V	L	column address	4
	Auto precharge enable										H	address	4,5
Write	Auto precharge disable	H	X	L	H	L	L	L	X	V	L	column address	4
	Auto precharge enable										H	address	4,5
Block write	Auto precharge disable	H	X	L	H	L	L	H	X	V	L	column address	
	Auto precharge enable										H	address	
Burst stop		H	X	L	H	H	L	X	X	X	X	X	6
Precharge	Selected bank	H	X	L	L	H	L	X	X	V	L		
	Both banks									X	H		
Clock suspend or active powerdown	Entry	H	L	H	X	X	X	X	X	X	X	X	
	Exit	L	H	L	V	V	V	V	X	X	X	X	
Precharge powerdown mode	Entry	H	L	H	X	X	X	X	X	X	X	X	
	Exit	L	H	H	X	X	X	X	X	X	X	X	
DQM		H	X	X	X	X	X	X	V	X	X	X	7
Deselect device		H	X	H	X	X	X	X	X	X	X	X	
No operation		H	X	L	H	H	H	X	X	X	X	X	

1 OP = operation code  
A0~A8, BA see above.

2 MRS can be issued only when both banks are precharged. A new command can be issued 2 clock cycles after MRS.

3 Auto refresh functions similarly to CBR DRAM refresh. However, precharge is automatic.  
Auto/self refresh can only be issued after both banks are precharged.

4 A8: bank select address. If low during read, write, row active and precharge, bank A is selected.  
If high during those states, bank B is selected. Both banks are selected and A8 is ignored if A7 is high during row precharge.

5 A new read/write command cannot be issued during a burst read/write with auto precharge.  
It must be issued after the end of the burst. A new row active command can be issued after  $t_{RP}$  from the end of the burst.

6 Burst stop command valid at every burst length.

7 DQM sampled at positive edge of CLK. Data-in may be masked at every CLK (Write DQM latency is 0).  
Data-out mask is active 2 CLK cycles after issuance. (Read DQM latency is 2).



## Mode register fields

Register programmed with MRS

Address	BA	A8	A7	A6	A5	A4	A3	A2	A1	A0
Function	Write mode		CR		IT mode		BT	burst length		

RFU = 0 during MRS cycle.

Write burst length

BA	A8	Mode
0	0	Normal
1	0	Multiple burst with single write

Burst type

A3	Type
0	Sequential
1	Interleaved

Color register

A7	Registers
0	One color
1	Two color

CAS latency

A6	A5	A4	Latency
0	0	0	Reserved
0	0	1	1
0	1	0	2
0	1	1	3
1	X	X	Reserved

Burst length

A2	A1	A0	BT = 0
0	0	0	1
0	0	1	2
0	1	0	4
0	1	1	8
1	X	X	Reserved <sup>†</sup>

<sup>†</sup>Burst length = fullpage when A2~A0 = 1.

SGRAM



Burst sequence (burst length = 2)

Initial address					
A0		Sequential		Interleave	
0		0	1	0	1
1		1	0	1	0

Burst sequence (burst length = 4)

Initial address									
A1	A0	Sequential				Interleave			
0	0	0	1	2	3	0	1	2	3
0	1	1	2	3	0	1	0	3	2
1	0	2	3	0	1	2	3	0	1
1	1	3	0	1	2	3	2	1	0

Burst sequence (burst length = 8)

Initial address																				
A2	A1	A0	Sequential							Interleave										
0	0	0	0	1	2	3	4	5	6	7	0	1	2	3	4	5	6	7		
0	0	1	1	2	3	4	5	6	7	0	1	0	3	2	5	4	7	6		
0	1	0	2	3	4	5	6	7	0	1	2	3	0	1	6	7	4	5		
0	1	1	3	4	5	6	7	0	1	2	3	4	2	1	0	7	6	5	4	
1	0	0	4	5	6	7	0	1	2	3	4	5	6	7	0	1	2	3		
1	0	1	5	6	7	0	1	2	3	4	5	6	7	4	7	6	1	0	3	2
1	1	0	6	7	0	1	2	3	4	5	6	7	5	4	2	3	0	1		
1	1	1	7	0	1	2	3	4	5	6	7	6	5	4	3	2	1	0		

SGRAM



## Pin descriptions

Pin	Name	Description
CLK	System clock	All operations synchronized to rising edge of CLK. CLK, driven by the system clock, increments the internal burst counter and controls output registers.
CKE	Clock enable	Controls CLK input. If CKE is high, the next CLK rising edge is valid. If CKE is low, the internal clock is suspended from the next clock cycle and the burst address and output states are frozen. If both banks are idle and CKE goes low, the SGRAM will enter power down mode from the next clock cycle. When in power down mode and CKE is low, no input commands will be acknowledged. To exit power down mode, raise CKE high before the rising edge of CLK.
$\overline{\text{CS}}$	Chip select	Enables or disables device operation by masking or enabling all inputs except CLK, CKE, DQM. Input commands are ignored when $\overline{\text{CS}} = \text{High}$ .
A0~A8	Address	Row and column addresses are multiplexed. Row address: A0~A8 during Active command. Column address: A0~A7 when $\overline{\text{CAS}}$ is active; A8 enables/disables Auto Precharge.
BA	Bank select	Memory cell array is organized in 2 banks. BA selects which internal bank will be active. BA is latched during bank activate, read, write, mode register set, and precharge operations. Asserting BA low selects Bank A; BA high selects Bank B.
$\overline{\text{RAS}}$	Row address strobe	Enables row access and precharge operation. When $\overline{\text{RAS}}$ is low, row address is latched at the rising edge of CLK.
$\overline{\text{CAS}}$	Column address strobe	Enables column access. When $\overline{\text{CAS}}$ is low, column address is latched at the rising edge of CLK.
$\overline{\text{WE}}$	Write enable	Enables write operation and row precharge operation. When $\overline{\text{WE}}$ is low, input data is latched starting from $\overline{\text{CAS}}$ .
DQM 0~3	Output disable/ write mask	Controls I/O buffers. When DQM is high, output buffers are disabled during a read operation and input data is masked during a write operation. DQM latency is 2 clocks for Read and 0 clocks for Write.
DQ 0~DQ 31	Data input/output	Data inputs/outputs are multiplexed. Input mask for Write-per-bit; column address mask when block write is active.
DSE	Special function variable	Enables block write, write-per-bit, and/or special mode register load.
$V_{\text{DD}}/V_{\text{SS}}$	Power supply/ground	Power and ground for core logic and input buffers.
$V_{\text{DDQ}}/V_{\text{SSQ}}$	Data output power/ground	Power and ground for data output buffers.



## Device operation

Command	Pin settings	Description
Power up		<p>The following sequence is recommended prior to normal operation.</p> <ol style="list-style-type: none"> <li>1. Apply power, start clock, and hold all inputs high.</li> <li>2. After power-up, pause for a minimum of 100µs. Drive CKE high prior to a positive clock edge; all others NOP.</li> <li>3. Precharge both banks.</li> <li>4. Perform a minimum of 2 auto refresh cycles to stabilize internal circuitry.</li> <li>5. Perform Mode Register Set command to initialize mode register.</li> </ol>
Mode register set	$\overline{CS} = \overline{RAS} = \overline{CAS} = \overline{WE} = \text{low}; A0 \sim A8 = \text{opcode}$	<p>The mode register stores the user selected opcode for the SGRAM operating modes. The CAS latency, burst length, burst type, test mode and other vendor specific functions are selected/programmed during the Mode Register Set command cycle. The default setting of the mode register is not defined after power-up. Therefore, it is recommended that the power-up and mode register set cycle be executed prior to normal SGRAM operation. Refer to the Mode Register Set table and timing for details.</p>
Special mode register set		<p>Use this command to load the mask and color registers used in block write and masked write cycles. Control information is applied to address inputs; data to be written to color or mask registers is applied to DQs. If A6 = 1, and all other inputs are 0, color register 0 receives DQ data. If A6 = A7 = Mode Register M7 = 1, color register 1 receives DQ data. If A5 = 1 and all other address inputs are 0, mask register receives DQ data.</p>
Device deselect and no operation (NOP)	$\overline{CS} = \text{high}$	<p>The SGRAM is deselected when <math>\overline{CS}</math> is high. <math>\overline{CS}</math> high disables the command and decoder such that RAS, CAS, <math>\overline{WE}</math> and address inputs are ignored. Device deselection is also considered a NOP. The SGRAM also performs a NOP when <math>\overline{RAS}</math>, <math>\overline{CAS}</math>, and <math>\overline{WE} = \text{high}</math>. Since the NOP performs no operation, it may be used as a wait state in performing normal SGRAM functions.</p>
Bank activation	$\overline{CS} = \overline{RAS} = \text{low}; \overline{CAS} = \overline{WE} = \text{high}; A0 \sim A8 = \text{row address}; BA = \text{bank select}$	<p>The SGRAM is configured with two internal banks. Use the Bank Activate command to select a row in one of the two idle banks. Initiate a read or write operation after <math>t_{RCD}</math> (min) from the time of bank activation.</p>
Bank activation with WPB		<p>Write-per-bit is activated during a Bank Activation command. All write or block write cycles to the selected bank/row are masked based on the mask register.</p>
Burst read	$\overline{CS} = \overline{CAS} = A8 = \text{low}; \overline{RAS} = \overline{WE} = \text{high}; BA = \text{bank select}; A0 \sim A7 = \text{column address}$	<p>Use the Burst Read command to access a consecutive burst of data from an active row in an active bank. Burst read can be initiated on any column address of an active row. The burst length, sequence and latency are determined by the mode register setting. The first output data appears after the CAS latency from the read command. The output goes into a high impedance state at the end of the burst (BL = 1, 2, 4, 8) unless a new burst read is initiated to form a gapless output data stream. Terminate the burst with a burst stop command, precharge command to the same bank or another burst read/write.</p>
Burst write	$\overline{CS} = \overline{CAS} = \overline{WE} = A10 = \text{low}; \overline{RAS} = \text{high}; A0 \sim A8 = \text{column address}$	<p>Use the Burst Write command to write data into the SGRAM on consecutive clock cycles to adjacent column addresses. The burst length and addressing mode is determined by the mode register opcode. Input the initial write address in the same clock cycle as the Burst Write command. Terminate the burst with a burst stop command, precharge command to the same bank or another burst read/write. DQM can also be used to mask the input data.</p>



Command	Pin settings	Description
Block write		Use block write to write a single data value to a block of eight consecutive column locations addressed by A7-A3. A Special Mode Register Set command must occur before a block write to assign this data to the color register. Input data on DQs is used to mask specified column/byte combinations within the block.
DQM operation		Use DQM to mask input and output data. It disables the output buffers in a read operation and masks input data in a write operation. The output data is tri-stated 2 clocks after DQM assertion (2 clock latency). Input data is masked on the same clock as DQM assertion (0 clock latency).
Burst stop	$\overline{CS} = \overline{WE} = \text{low}; \overline{RAS} = \text{CAS} = \text{high}$	Use burst stop to terminate burst operation. This command may be used to terminate all legal burst lengths.
Bank precharge	$\overline{CS} = A8 = \overline{RAS} = \overline{WE} = \text{low}; \overline{CAS} = \text{high}; BA = \text{bank select}; A0 \sim A7 = \text{don't care}$	The Bank Precharge command precharges the bank specified by BA. The precharged bank is switched from active to idle state and is ready to be activated again. Assert the precharge command after $t_{RAS}$ (n in) of the bank activate command in the specified bank. The precharge operation requires a time of $t_{RP}$ (n in) to complete.
Precharge all	$\overline{CS} = \overline{RAS} = \overline{WE} = \text{low}; \overline{CAS} = A8 = \text{high}; BA = \text{bank select}; A0 \sim A7 = \text{don't care}$	The Precharge All command may be used to precharge both banks simultaneously. If A8 is high, BA is a don't care and both banks are simultaneously precharged. If A8 is low, BA specifies which bank is to be precharged. Both banks are switched to the idle state on precharge completion.
Auto precharge	$\overline{CS} = \overline{CAS} = \overline{WE} = \text{low}; \overline{RAS} = \overline{WE} = \text{read} = \text{low}; A8 = \text{high}; BA = \text{bank select}; A0 \sim A7 = \text{column address}$	During auto precharge, the SGRAM adjusts internal timing to satisfy $t_{RAS}$ (n in) and $t_{RP}$ for the programmed CAS latency and burst length. Couple the auto precharge with a burst read/write operation by asserting A8 to a high state at the same time the burst read/write commands are issued. At auto precharge completion, the specified bank is switched from active to idle state. Note that no new commands can be issued until the specified bank achieves the idle state.
Clock suspend/ power down mode entry	CKE = low	When CKE is low, the internal clock is frozen or suspended from the next clock cycle and the state of the output and burst address are frozen. If both banks are idle and CKE goes low, the SGRAM enters power down mode at the next clock cycle. When in power down mode, no input commands are acknowledged as long as CKE remains low. To exit power down mode, raise CKE high before the rising edge of CLK.
Clock suspend/ power down mode exit	CKE = high	Resume internal clock operation by asserting CKE high before the rising edge of CLK. Subsequent commands can be issued one clock cycle after the end of the Exit command.



Command	Pin settings	Description
Auto refresh	$\overline{CS} = \overline{RAS} = \overline{CAS} = \text{low};$ $\overline{WE} = \text{CKE} = \text{high};$ $A0 \sim BA = \text{don't care}$	<p>SGRAM storage cells must be refreshed every 64ms to maintain data integrity. Use the Auto Refresh command to accomplish the refreshing of all rows in both banks of the SGRAM. The row address is provided by an internal counter which increments automatically. Auto refresh can only be asserted when both banks are idle and the device is not in the power down mode. The time required to complete the auto refresh operation is <math>t_{RC}</math> (min). Use NOPs in the interim until the auto refresh operation is complete. This is the most common refresh mode. It is typically performed once every 15.6us or in a burst of 1024 auto refresh cycles every 64ms. Both banks will be in the idle state after this operation.</p>
Self refresh	$\overline{CS} = \overline{RAS} = \overline{CAS} = \text{CKE} =$ $\text{low}; \overline{WE} = \text{high}; A0 \sim BA$ $= \text{don't care}$	<p>Self refresh is another mode for refreshing SGRAM cells. In this mode, refresh address and timing are provided internally. Self refresh entry is allowed only when both banks are idle. The external clock and all input buffers with the exception of CKE are disabled in this mode. Exit self refresh by restarting the external clock and then asserting CKE high. NOP's must follow for a time of <math>t_{RC}</math> (min) for the SGRAM to reach the idle state where normal operation is allowed. If burst auto refresh is used in normal operation, burst 1024 auto refresh cycles in immediately after exiting self refresh.</p>



### Mode register set command waveform

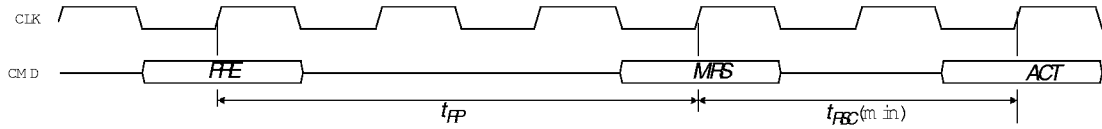

MRS can be issued only when both banks are idle.

### Precharge waveforms

Precharge can be asserted after  $t_{RAS}$  (m in). The selected bank will enter the idle state after  $t_{RP}$ . The earliest assertion of the precharge command without losing any burst data is shown below.

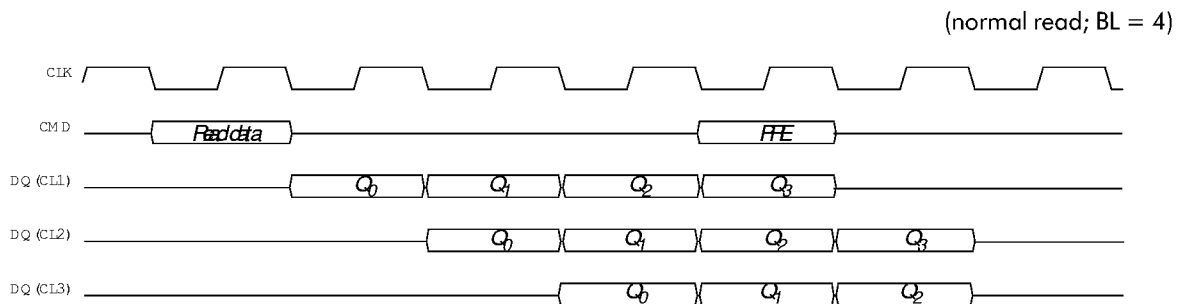
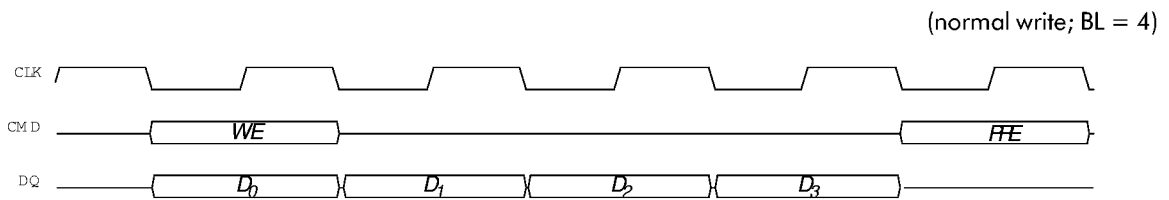

### Auto precharge waveforms

A8 controls the selection of auto precharge during the read or write command cycle.

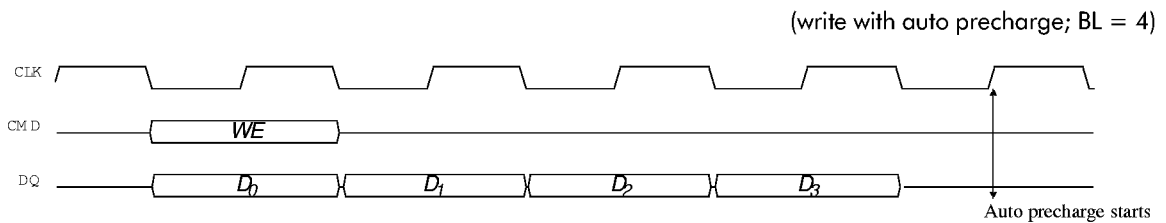



(read with auto precharge; BL = 4)

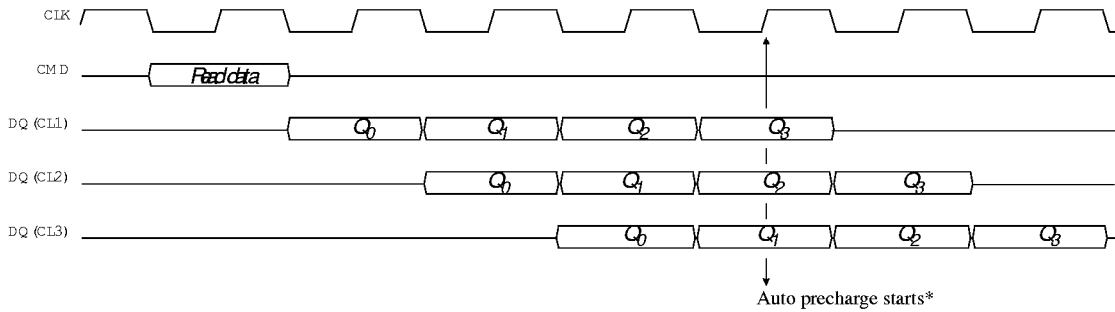

\*The row active command of the precharge bank can be issued after  $t_{RP}$  from this point. The new read/write command of another activated bank can be issued from this point. At burst read/write with auto precharge, CAS interrupt of the same/another bank is illegal.

Clock suspension read waveforms

(BL = 8)

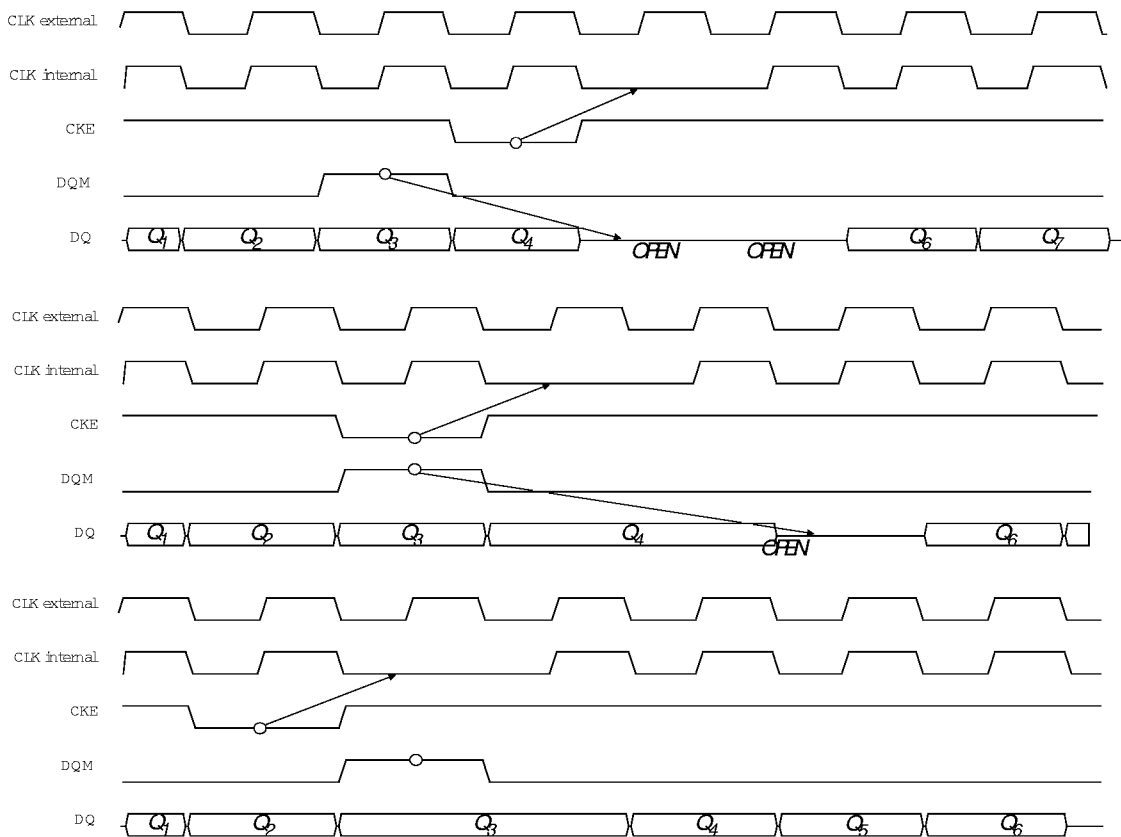

SGRAM



Clock suspension write waveforms

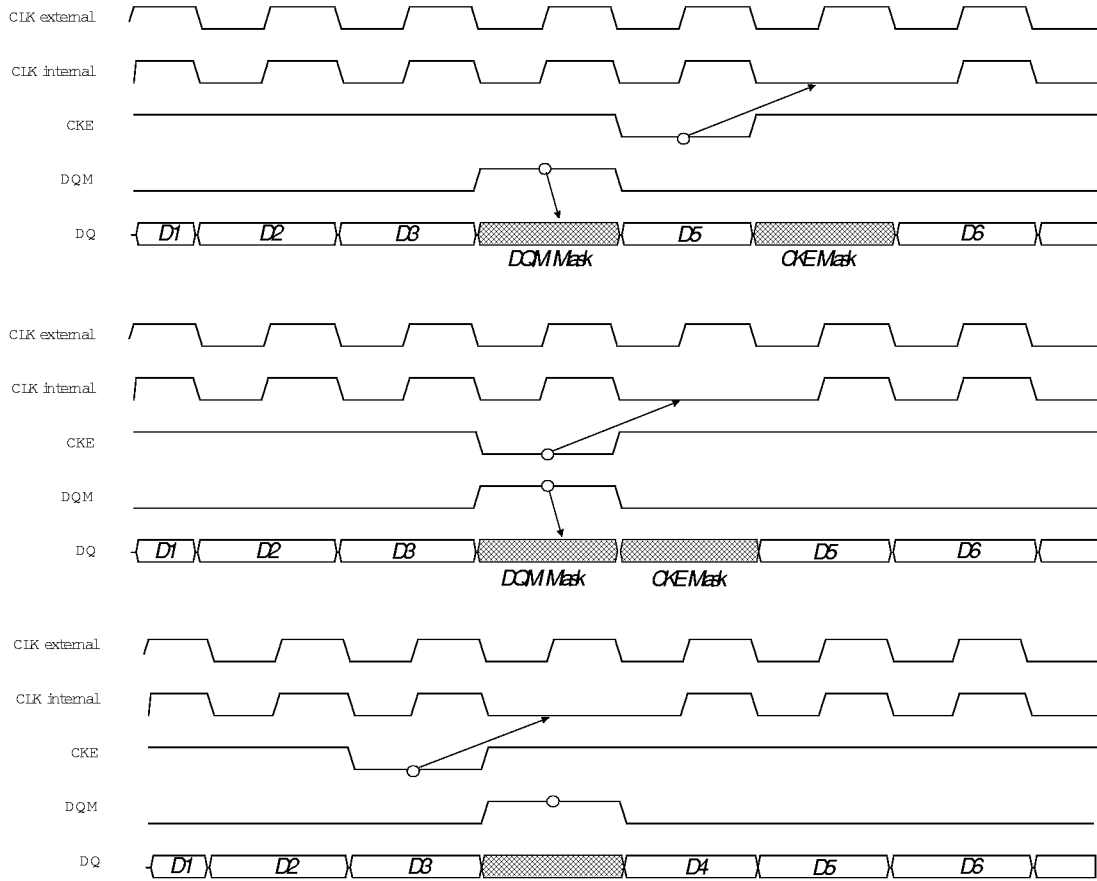

Read/write interrupt timing

read interrupted by read (BL = 4)

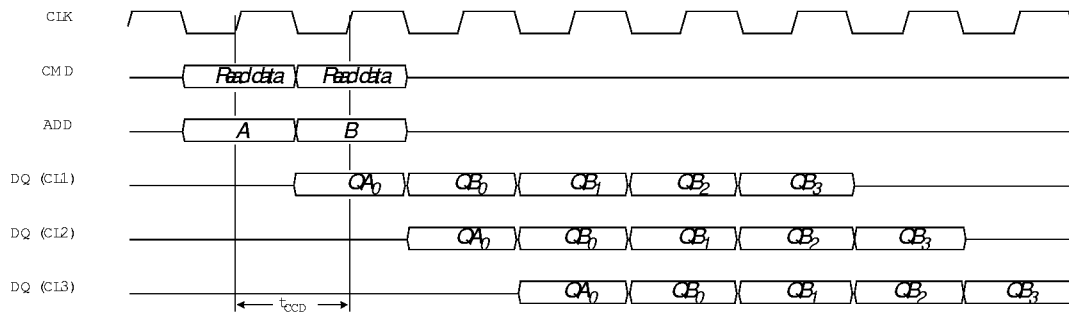

$t_{CD} = \overline{CAS}$  to  $\overline{CAS}$  delay (= 1 CLK)

SGRAM



write interrupted by write (BL = 4)

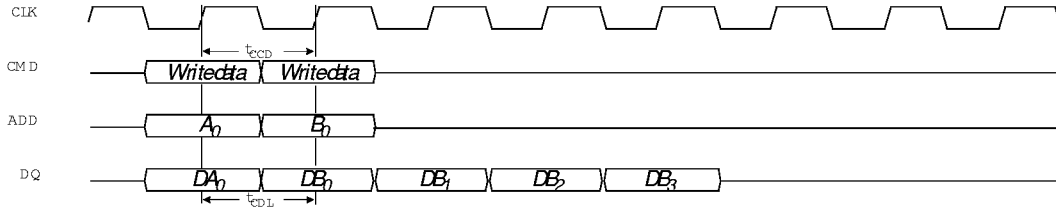

t<sub>CCD</sub> =  $\overline{\text{CAS}}$  to  $\overline{\text{CAS}}$  delay (= 1 CLK)

t<sub>CDL</sub> = last address in to new column address delay (= 1 CLK)

write interrupted by read (BL = 4)

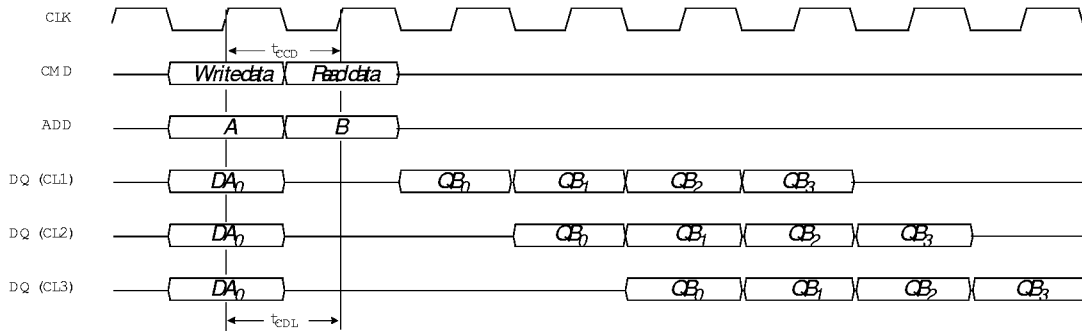

t<sub>CCD</sub> =  $\overline{\text{CAS}}$  to  $\overline{\text{CAS}}$  delay (= 1 CLK)

t<sub>CDL</sub> = last address in to new column address delay (= 1 CLK)

read interrupted by write (CL = 1, BL = 4)

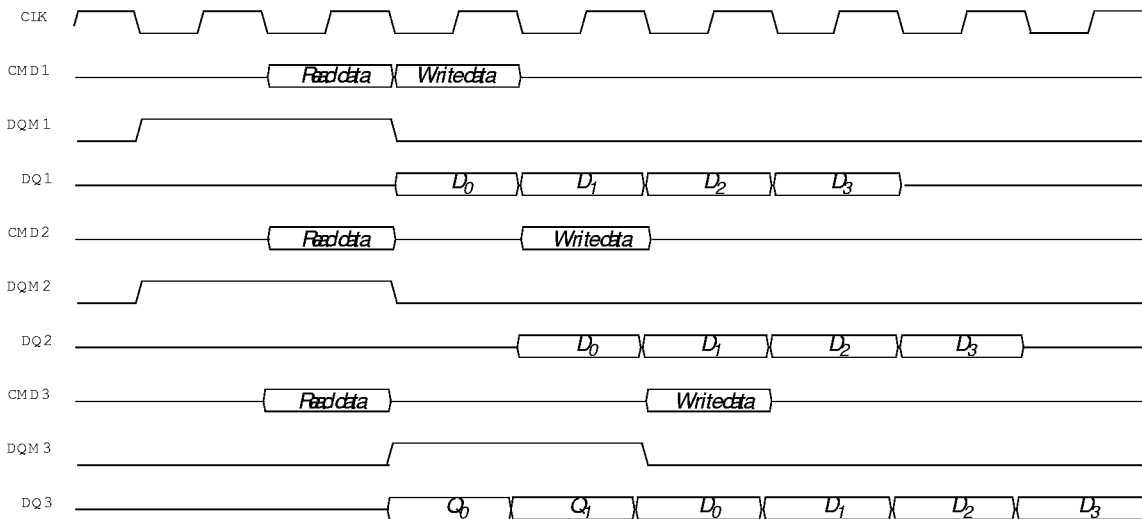

To prevent bus contention, maintain a gap between data in and data out.

SGRAM



read interrupted by write (CL = 2, BL = 4)

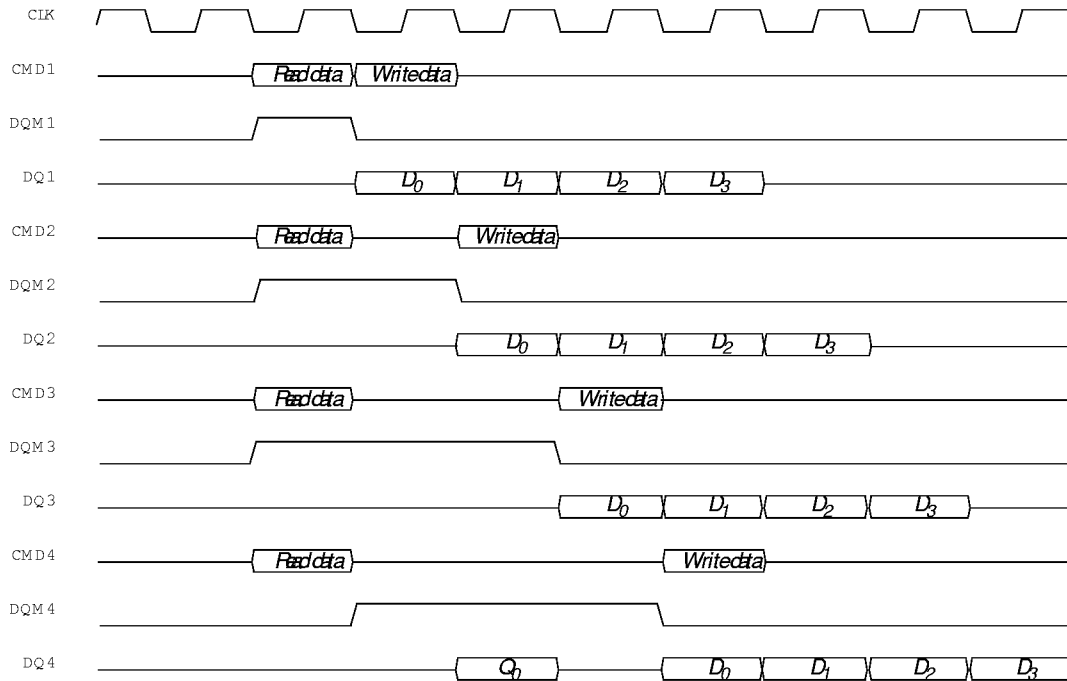

To prevent bus contention, maintain a gap between data in and data out.

read interrupted by write (CL = 3, BL = 4)

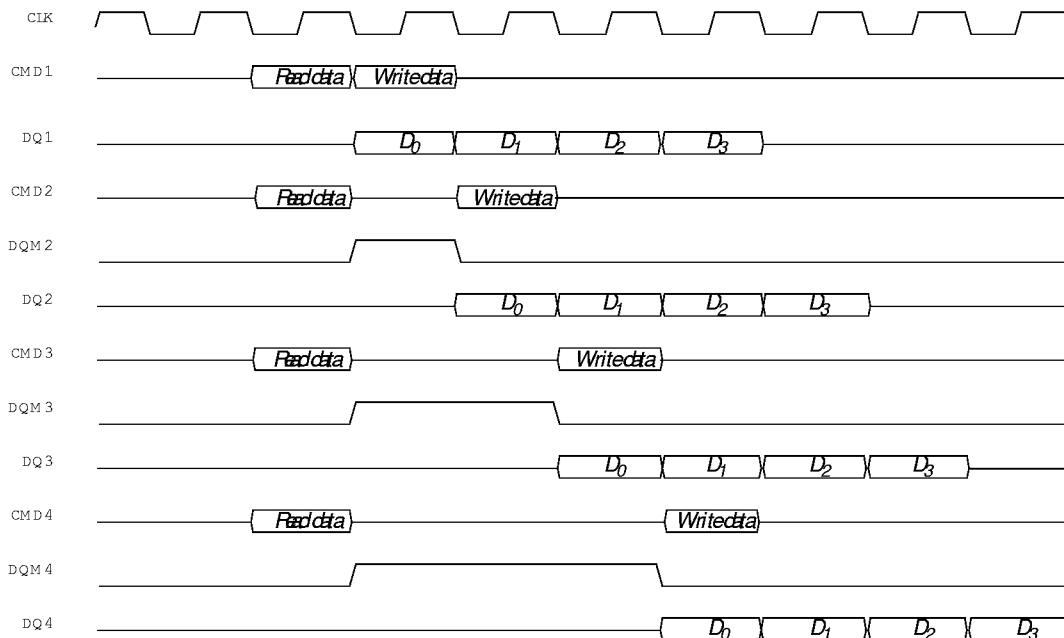

To prevent bus contention, maintain a gap between data in and data out.

SGRAM



### Burst termination

Burst operations may be terminated with a Read, Write, Burst Stop, or Precharge command. When Burst Stop is asserted during the read cycle, burst read data is terminated and the data bus goes to Hi-Z after CAS latency. When Burst Stop is asserted during the write cycle, burst write data is terminated and the data bus goes to Hi-Z simultaneously.

#### Burst stop command waveform

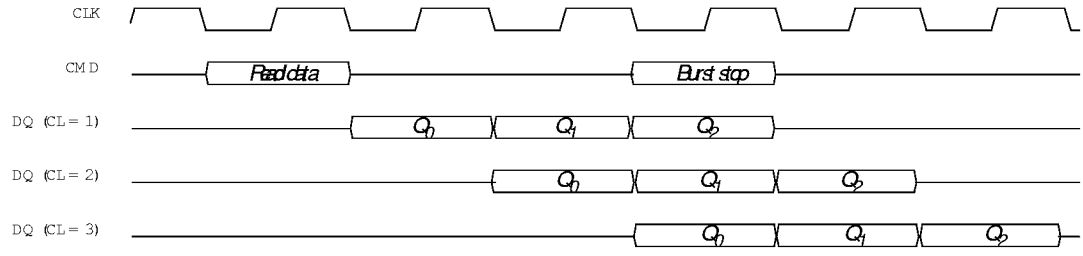

read cycle

write cycle (BL = 8)

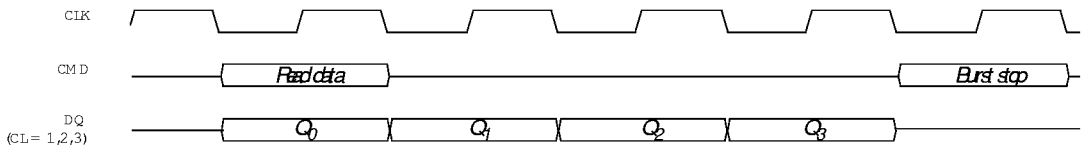

### Precharge termination

A Precharge command terminates a burst read/write operation during the read cycle. The same bank can be activated after meeting  $t_{RP}$ .

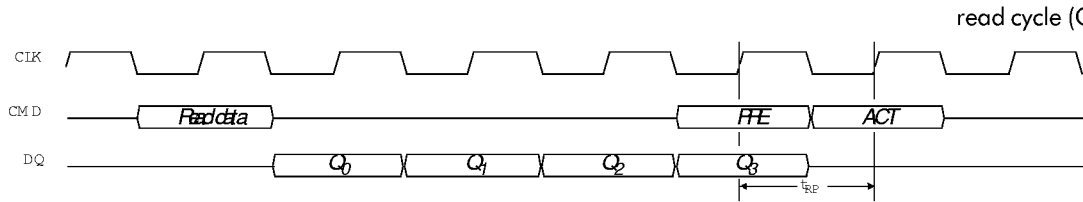

read cycle (CL = 1)

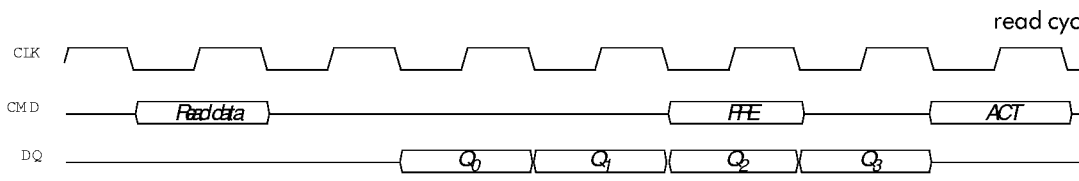

read cycle (CL = 2)

SGRAM



read cycle (CL = 3)

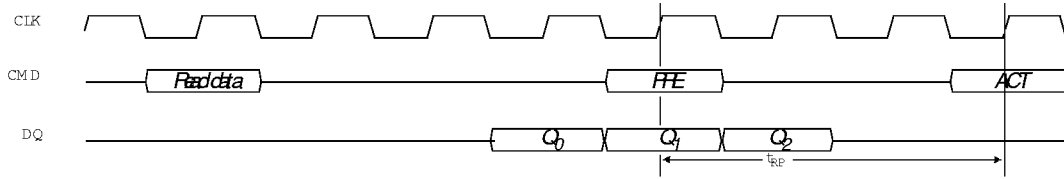

write cycle

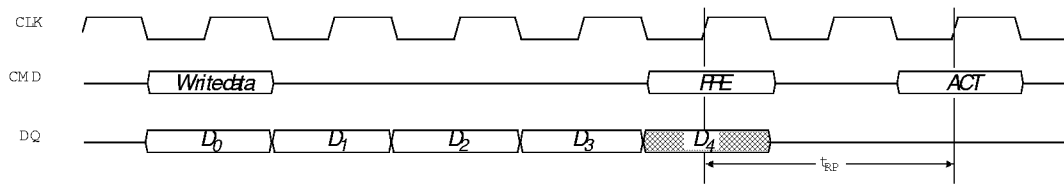

Auto refresh waveform

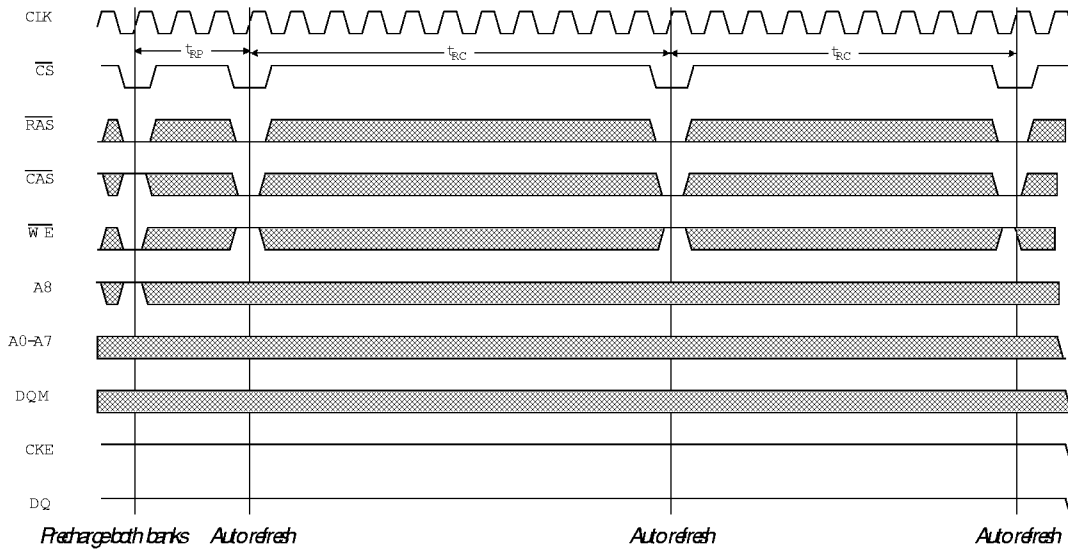



Self refresh waveform

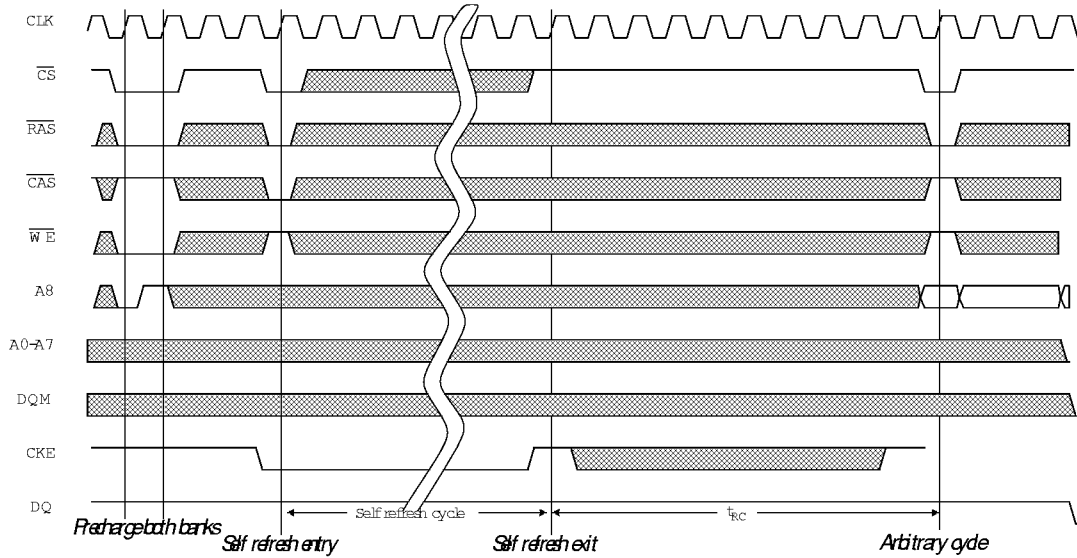

Power down mode waveform

(CL = 3)

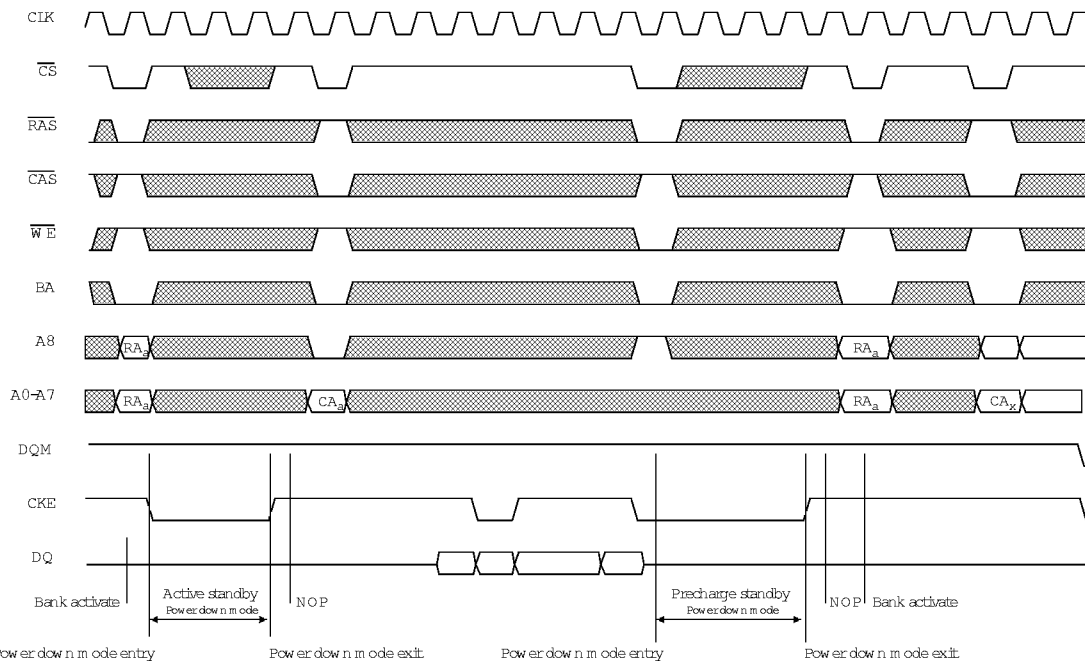

Enter power down mode by pulling CKE low.

All input/output buffers (except CKE buffer) are turned off in power down mode.

When CKE goes high, command and input must be equal to no operation at next CLK rising edge.





Read/write waveform

(BL = 8, CL = 3)

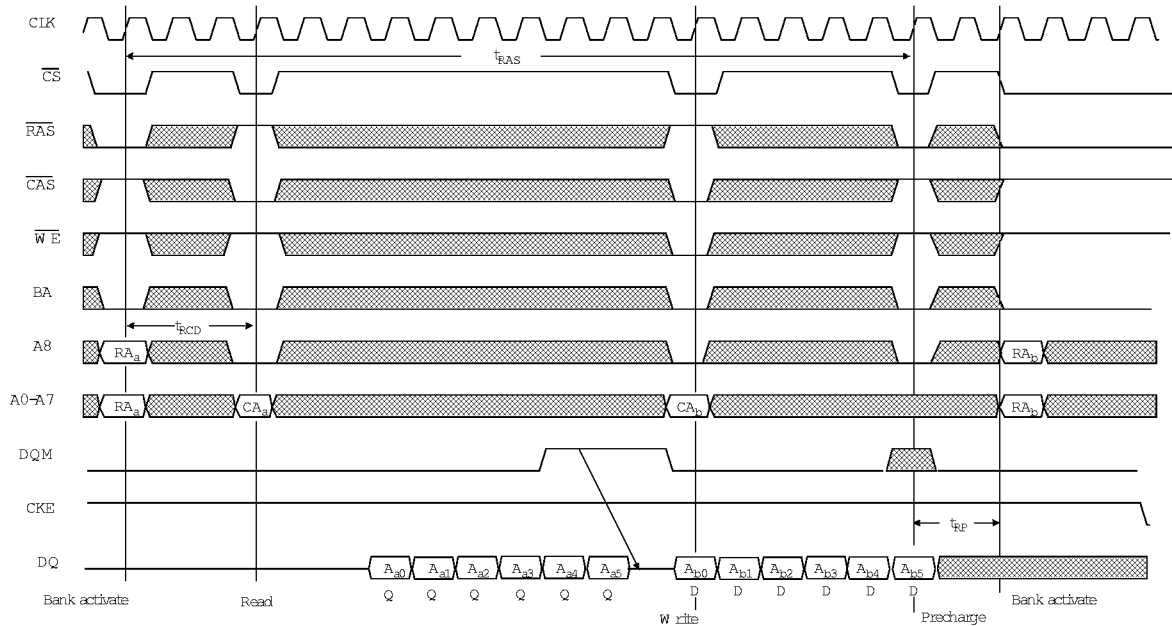

Burst read/single write waveform

(BL = 4, CL = 3)

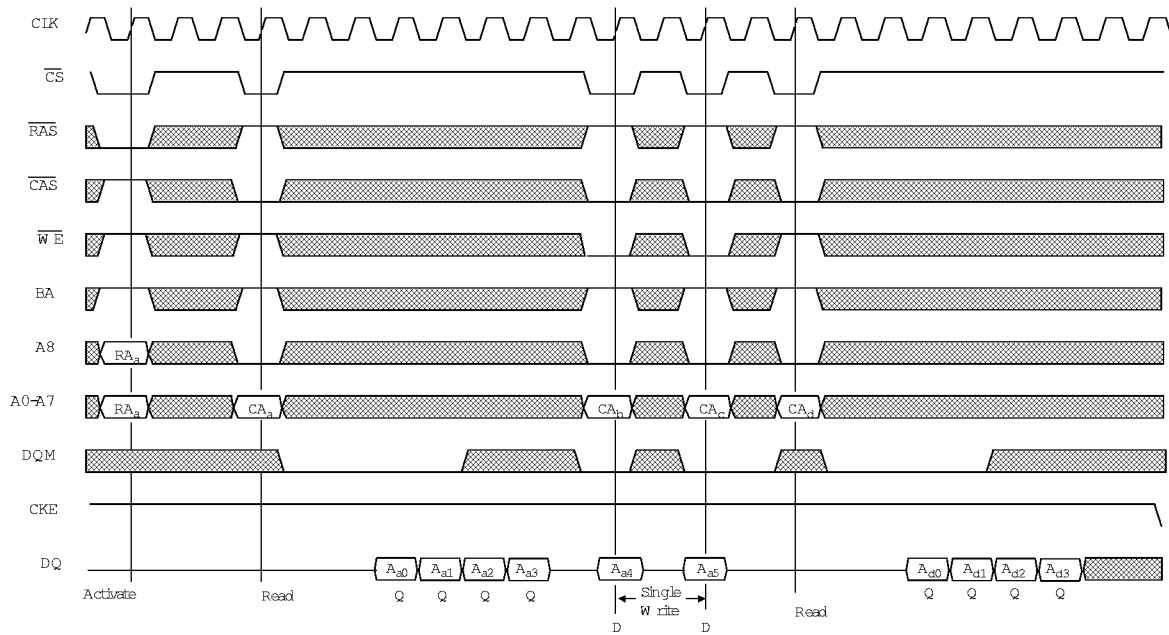

SGRAM



Interleaved bank read waveform

(BL = 4, CL = 3)

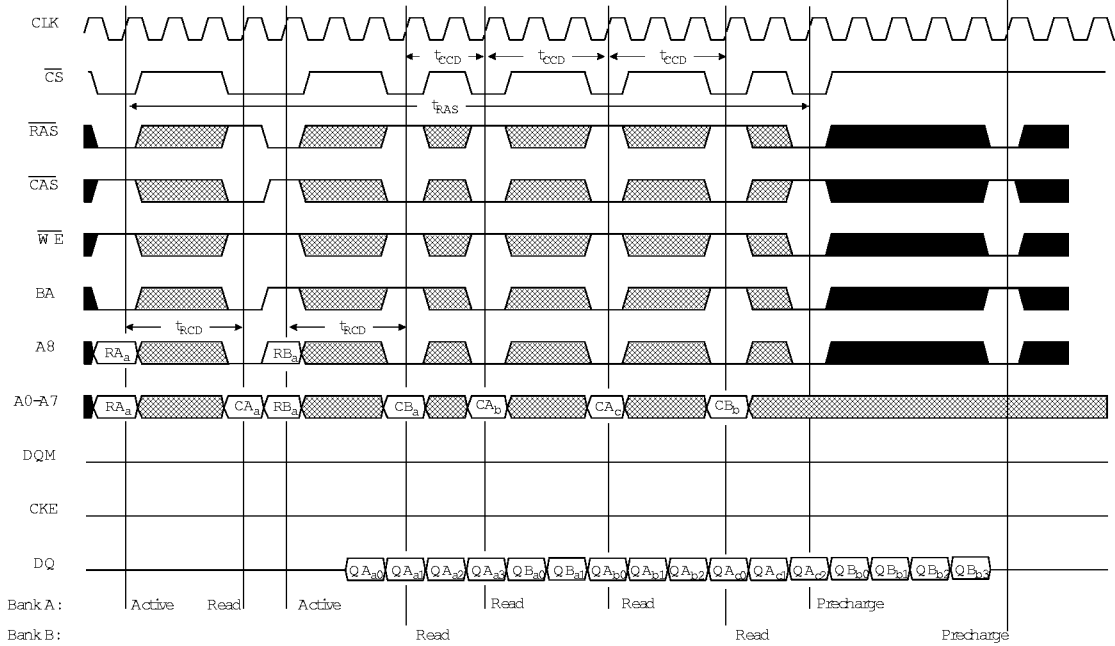

Interleaved bank read waveform

(BL = 4, CL = 3, Autoprecharge)

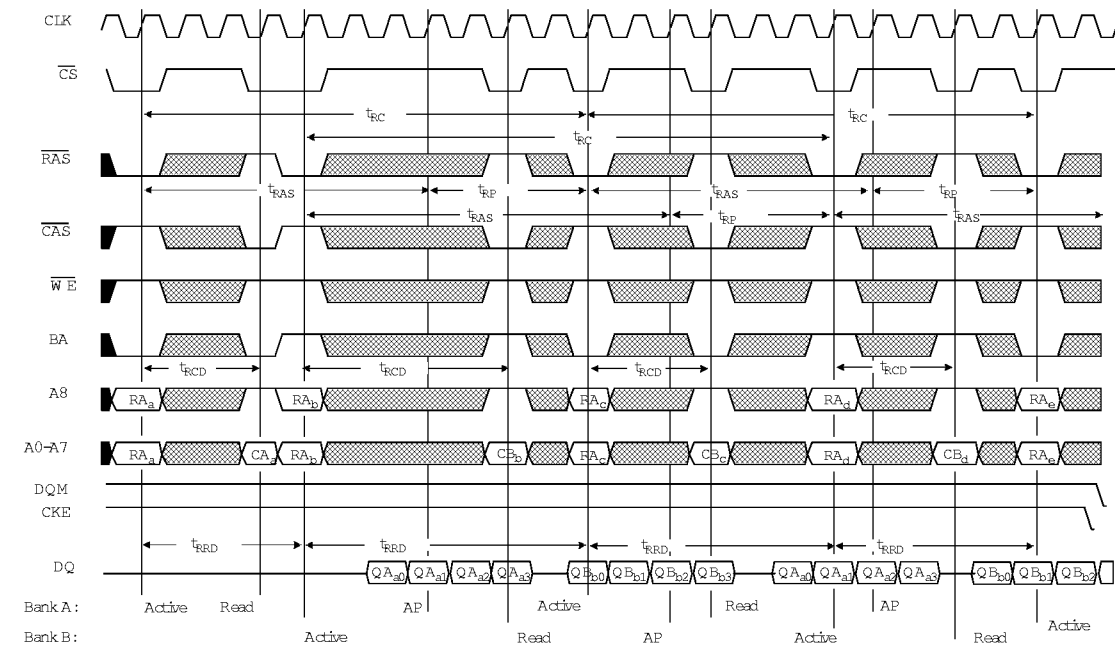

AP = internal precharge begins

SGRAM



Interleaved bank read waveform

(BL = 8, CL = 3)

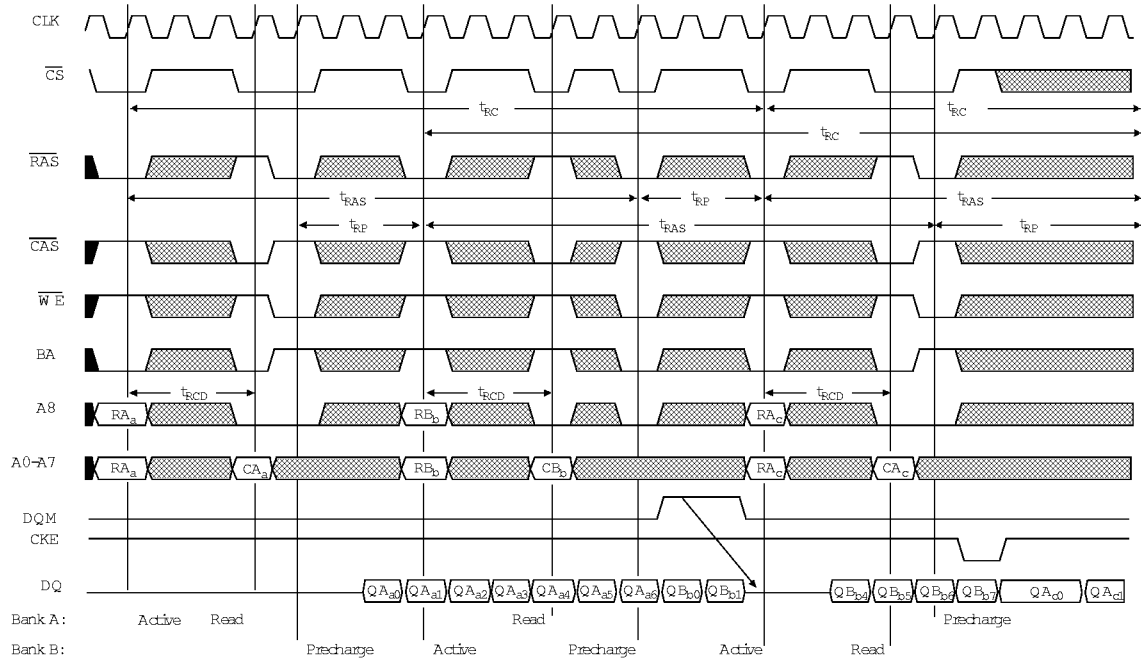

Interleaved bank read waveform

(BL = 8, CL = 3, Autoprecharge)

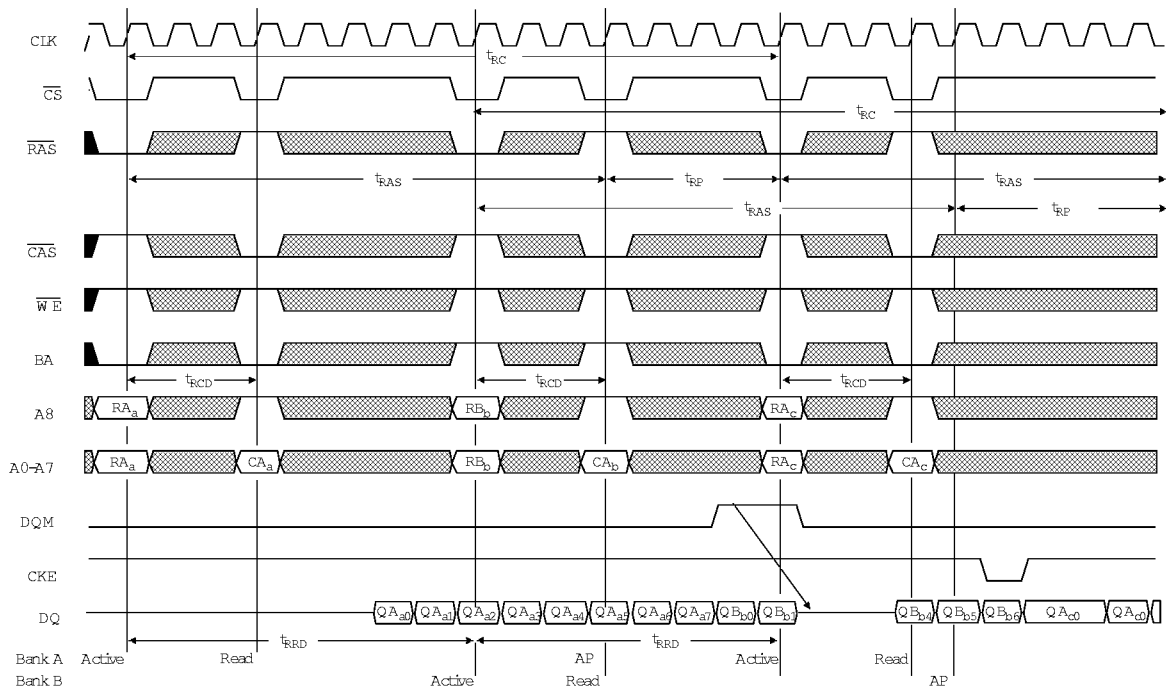

AP = internal precharge begins





Full page interleaved burst read waveform

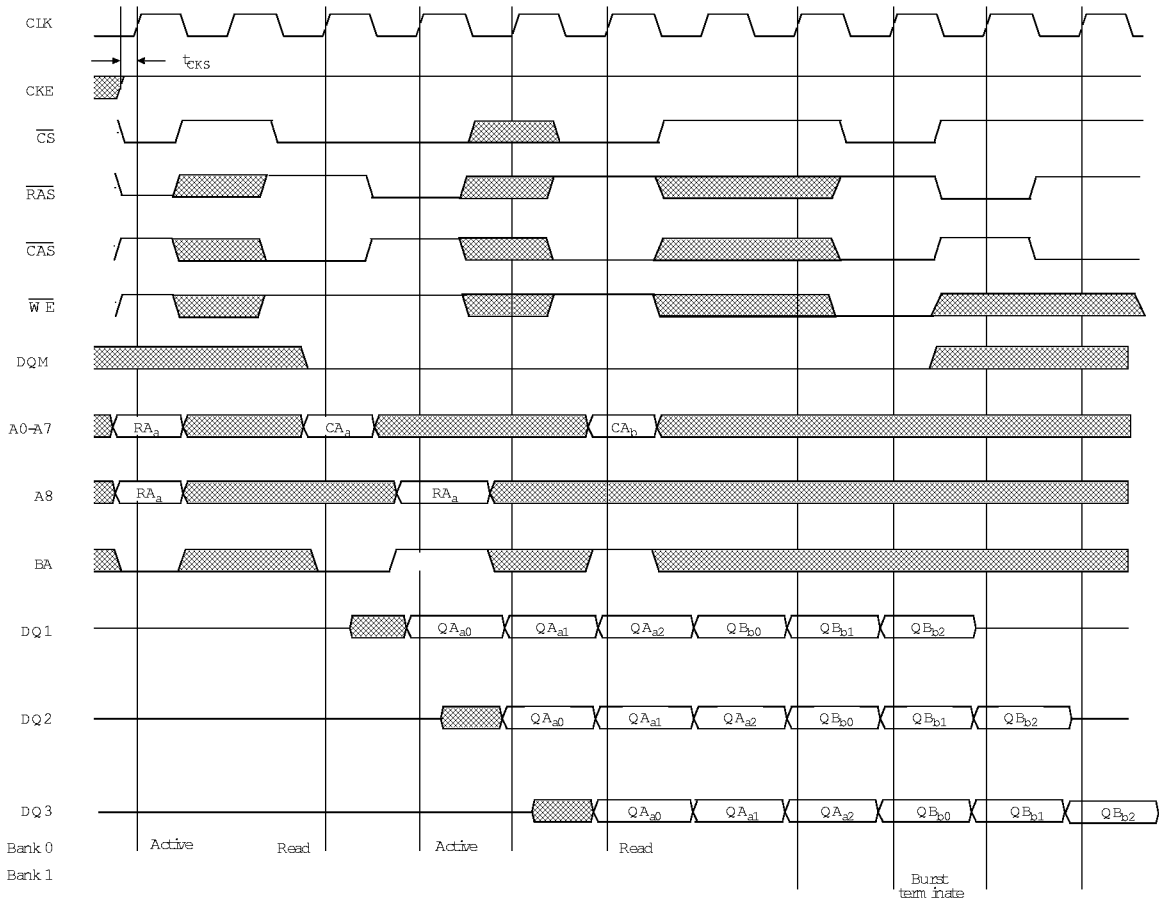

SGRAM



Interleaved bank write waveform

(BL = 8)

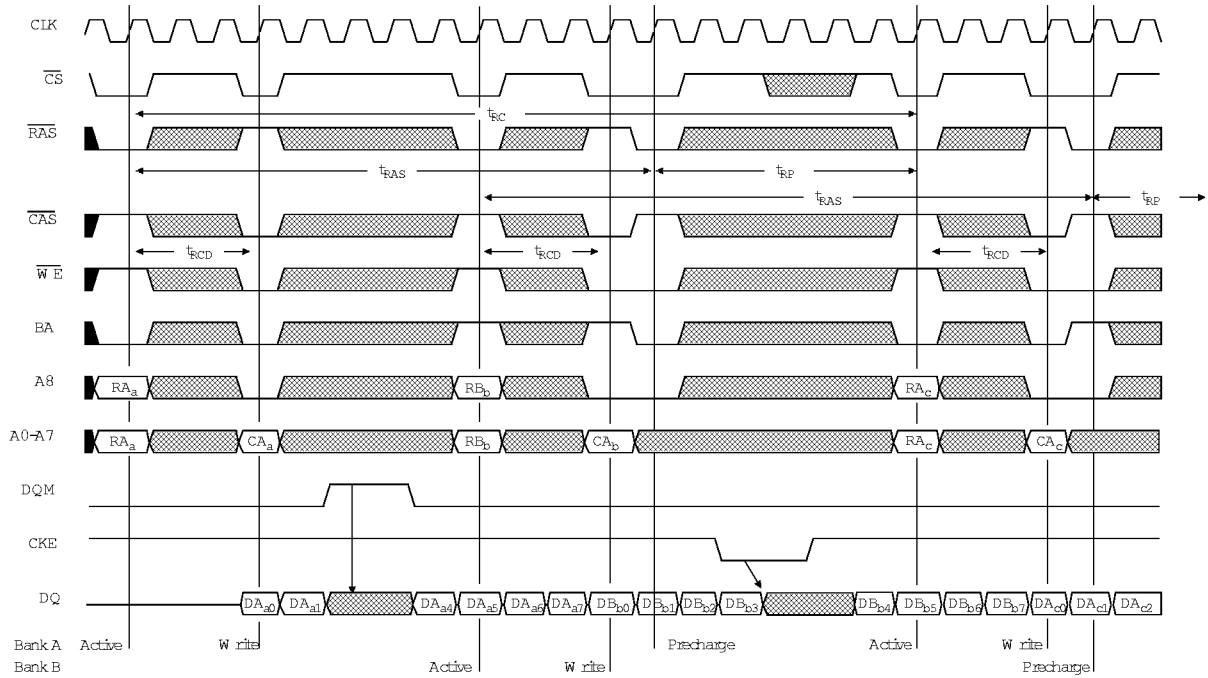

Interleaved bank write

(BL = 8, Autoprecharge)

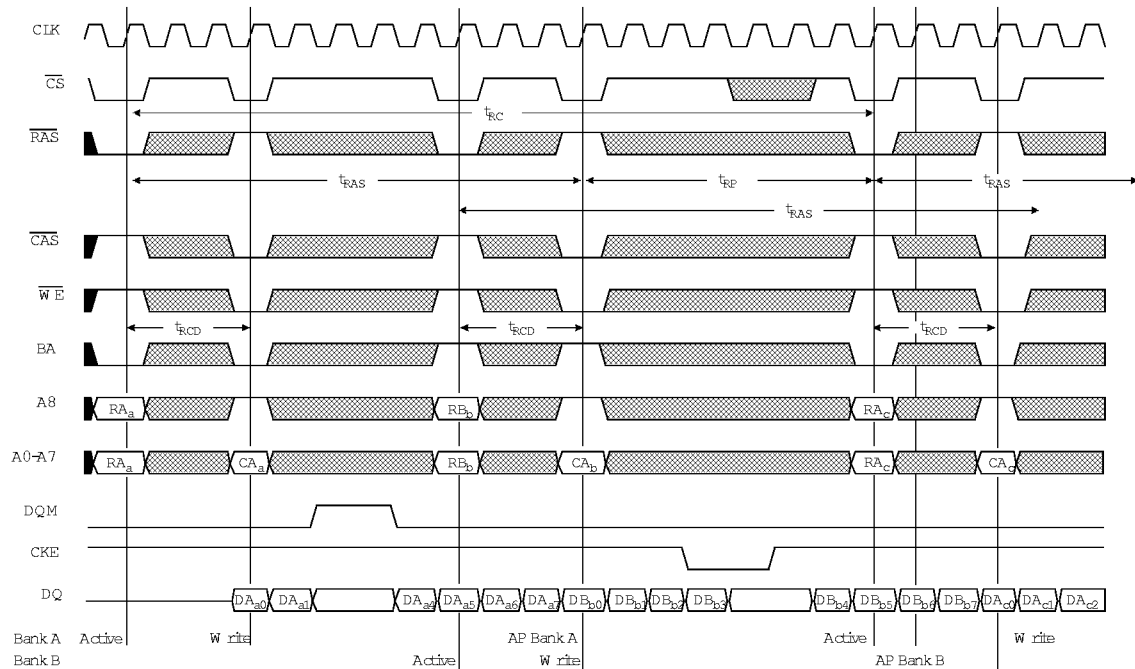

AP = internal precharge begins

SGRAM



Full page burst write waveform

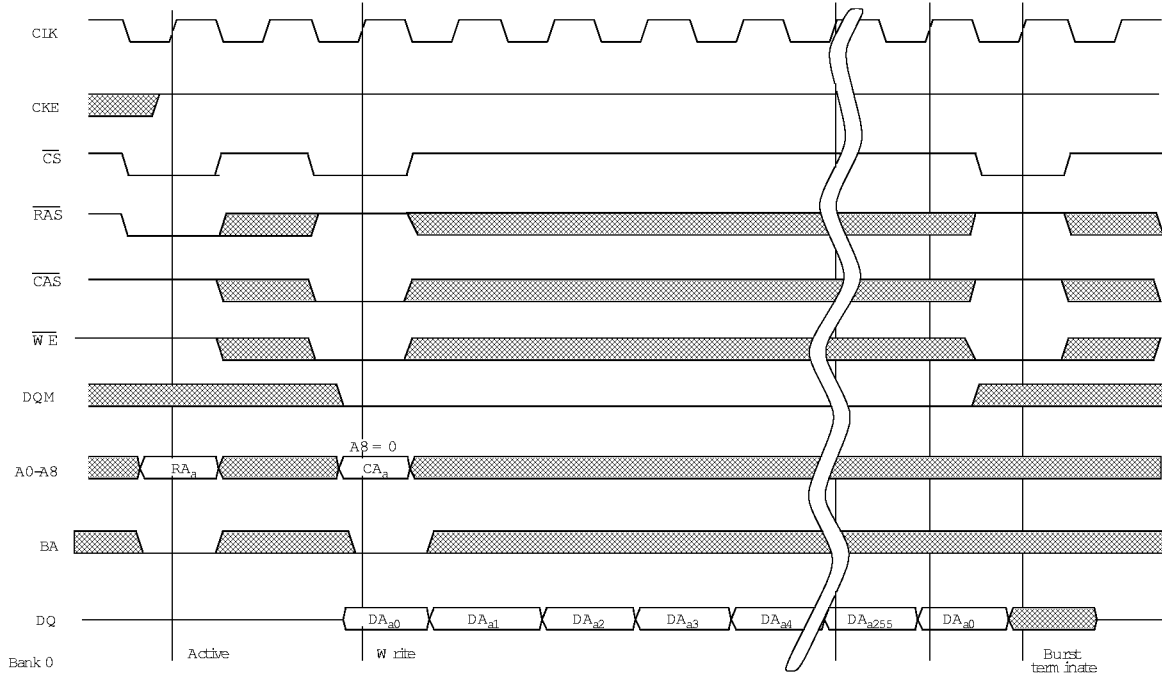

SGRAM



Block write

1 color register

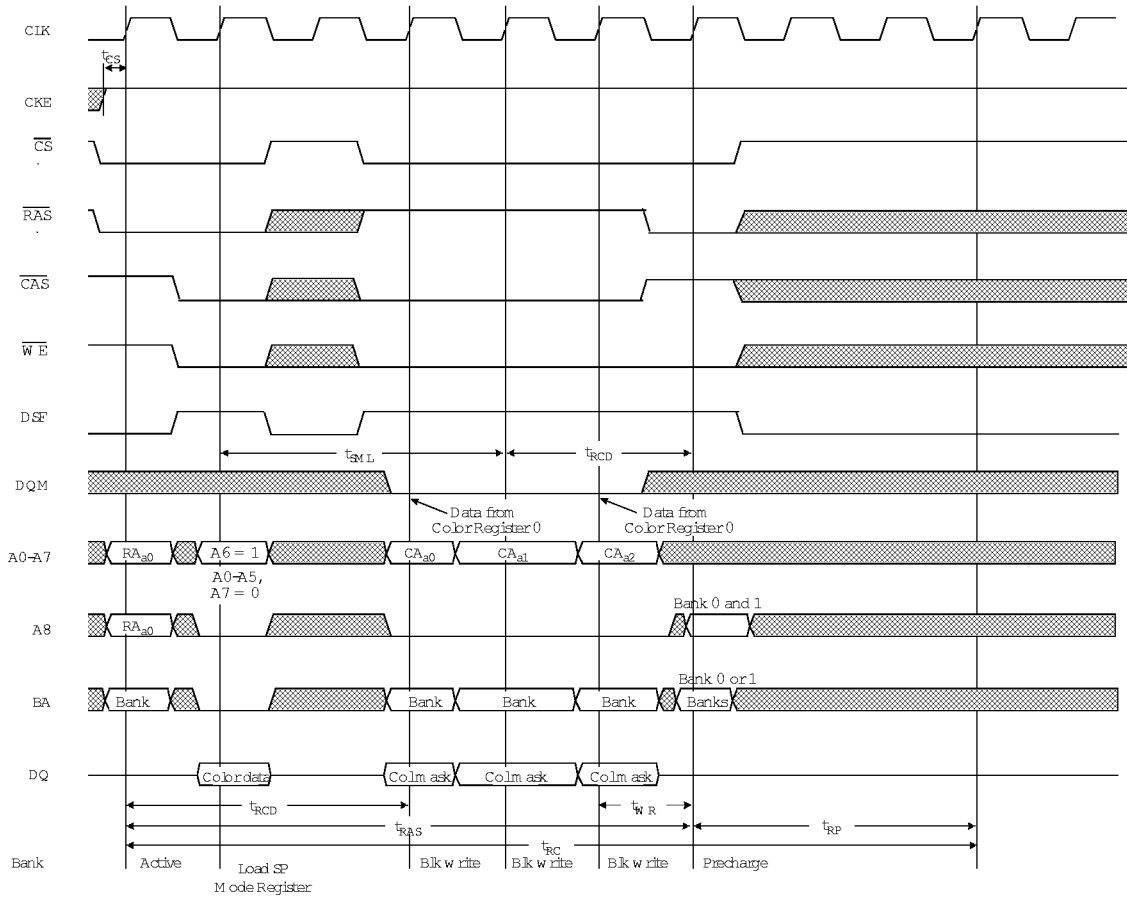



Block write

multiple color register

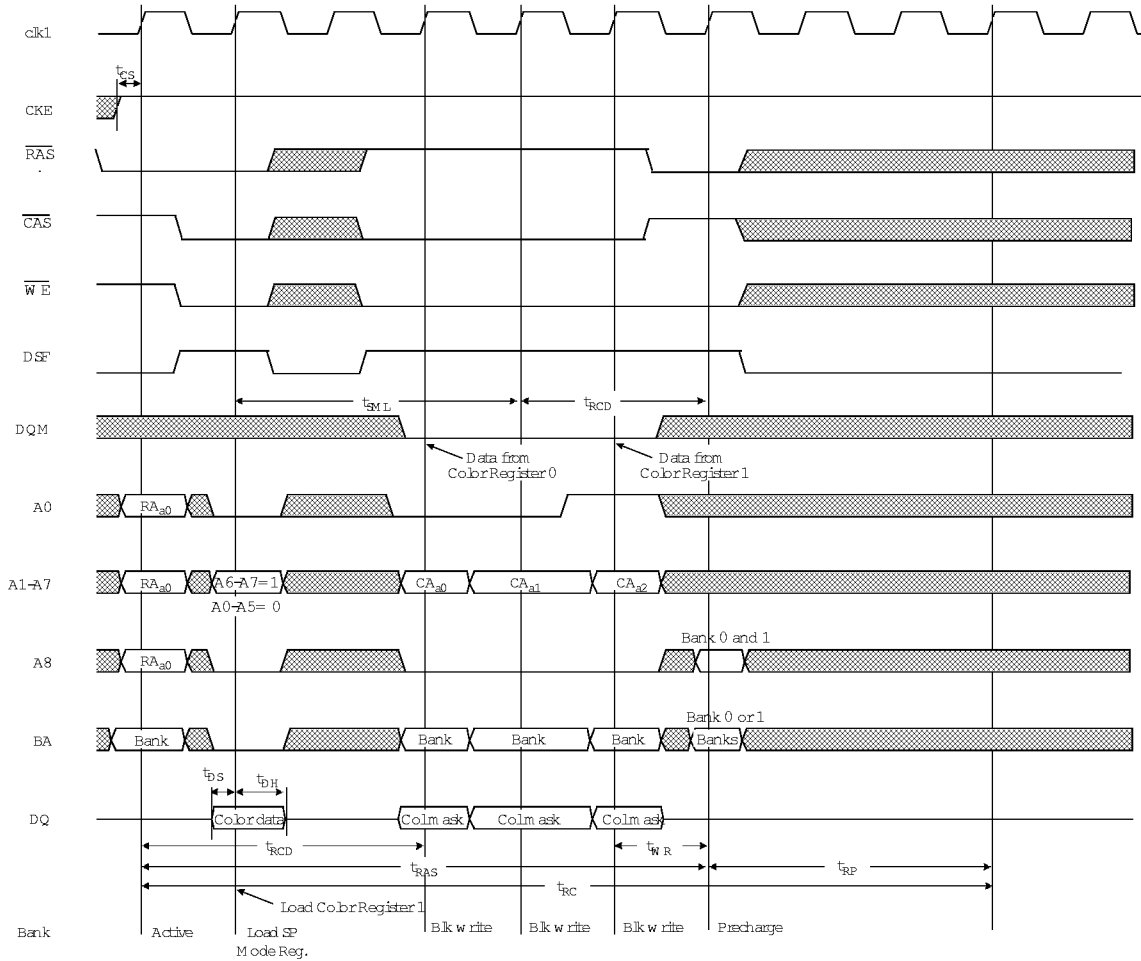

SGRAM



Block write diagram

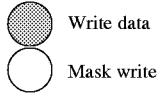

Column mask

- DQ<sub>0-7</sub> Column mask for DQ<sub>0-7</sub>
- DQ<sub>8-15</sub> Column mask for DQ<sub>8-15</sub>
- DQ<sub>16-23</sub> Column mask for DQ<sub>16-23</sub>
- DQ<sub>24-31</sub> Column mask for DQ<sub>24-31</sub>

Write per bit

Mask data = Mask register + DQM

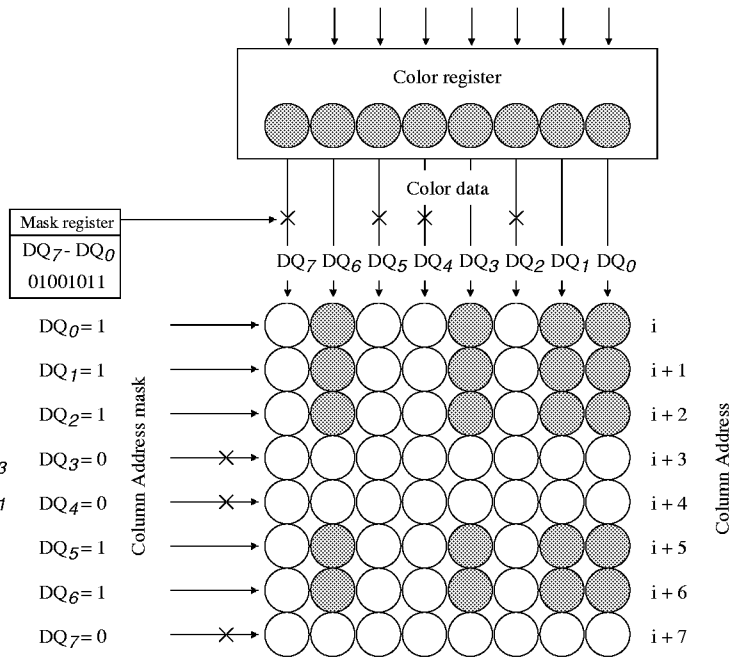

Package dimensions

	(P)QFP	
	Min	Max
A1	0.25	0.45
A2	2.57	2.87
b	0.20	0.40
c	0.10	0.20
D	13.90	14.10
E	19.90	20.10
e	0.65 nominal	
Hd	17.00	17.40
He	23.00	23.40
L	0.65	0.95
L1	1.60 nominal	
α	0°	10°

Dimensions in millimeters

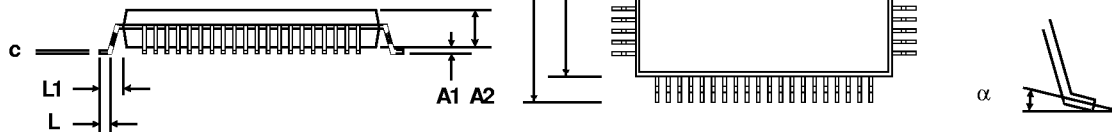

# AS4LC256K32S0



## AC test conditions

- Input reference levels of  $V_{IH} = 2.4V$  and  $V_{IL} = 0.8V$
- Output reference levels = 1.4V
- Input rise and fall times: 1 ns

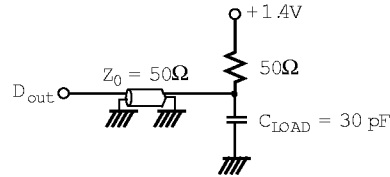

Figure A: Equivalent output load

## Capacitance

$f = 1 \text{ MHz}, T_a = 25^\circ\text{C}, V_{CC} = 3.3V$

Parameter	Symbol	Signals	Max	Unit
Input capacitance	$C_{IN1}$	A0 to BA	5	pF
	$C_{IN2}$	DQM, $\overline{\text{RAS}}$ , $\overline{\text{CAS}}$ , $\overline{\text{WE}}$ , $\overline{\text{CS}}$ , CLK, CKE, DSF	5	pF
I/O capacitance	$C_{I/O}$	DQ0 to DQ31	5	pF

## Part numbering system

AS4	LC	XXXXS0	-XX	XX	C
DRAM prefix	LC = 3.3V CMOS	Device number for synchronous DRAM	1/frequency	Package (device dependent): PQ = PQFP	Commercial temperature range, 0°C to 70 °C

## Ordering codes

Package/Frequency	150 MHz	133 MHz	100 MHz
Plastic PQFP, 100-pin, 14mm x 20mm	AS4LC256K32S0-150PQ	AS4LC256K32S0-133PQ	AS4LC256K32S0-100PQ

SGRAM