

Integrated Low Profile Transceiver Module for Telecom Applications – IrDA Standard



Description

The miniaturized TFDU4201 is an ideal transceiver for applications in telecommunications like mobile phones and pagers. The device is mechanically designed for lowest profile with a height of only 2.8 mm. The infrared transceiver is compatible to the IrDA Low Power physical layer specification version up to a data rate of 115 kbit/s. For higher output intensities with an identical package solution the TFDU4202 is designed.

Package

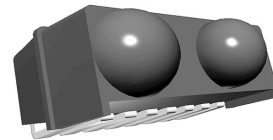

Features

- Package Dimension:
L 7.1 mm x W 4.55 mm x H 2.75 mm
- Compatible to IrDA Low Power Standard
- SMD Side View Soldering
- Lowest Power Consumption
55 μ A, Receive Mode, 1 μ A Shutdown
- Only 30 mA IRED Peak Current During Transmission
- Wide Supply Voltage Range (2.4 V to 3.6 V)
- Operational down to 2.0 V
- Fewest External Components
- Internal Current Control
- Tri-State Output (Rxd)
- High EMI Immunity
- **SD Pin**

Applications

Mobile Phones, Pagers, Personal Digital Assistants (PDA), Handheld Battery Operated Equipment

µFace SIR Selector Guide

Part Number	Main Feature	Rxd Output in Txd Mode	IRED Drive Capability	IrDA Compliance	Power Supply
TFDU4201	Low Power 20 cm/ 30 cm IrDA Standard SD pin	Optical Feedback**) (for e.g. self-test mode)	Internally current controlled, adjusted for $I_e > 4 \text{ mW/sr}$	Low Power SIR, pairs of TFDU4201 operate typically over a range of > 70 cm on axis	One power supply only, due to the very low current consumption no need for split power supply
TFDU4202	Split Power Supply Increased Range 70 cm	Quiet**) necessary for some WinCE® applications, Rxd grounded when $V_{CC} = 0 \text{ V}$	Internally current controlled to cover extended range of 70 cm. Current level can be reduced by an external resistor	Low Power SIR as e.g. TFDU4201, pairs of TFDU4202 operate typically up to full IrDA SIR distance >1 m	Split power supply*) can be used when operated at higher IRED current levels
TFDU4203	Similar to TFDU4201 with increased range 70 cm, SD pin	Quiet**) necessary for some WinCE® applications	Internally current controlled to cover extended range of 70 cm. Current level can be reduced by an external resistor	Low Power SIR as e.g. TFDU4201, pairs of TFDU4203 operate typically up to full IrDA SIR distance >1 m	One power supply only
TFDU4204	Similar to TFDU4202, Logic Input and Output Levels Adapted to 1.8 V Logic	Quiet**) necessary for some WinCE® applications, Rxd output is floating when supply voltage below 0.7 V	Internally current controlled to cover extended range of 70 cm. Current level can be reduced by an external resistor	Low Power SIR as e.g. TFDU4201, pairs of TFDU4204 operate typically up to full IrDA SIR distance >1 m	Split power supply*) can be used when operated at higher IRED current levels

*) Split power supply: The receiver circuit only is connected to a regulated power supply. The high IRED current can be supplied by a less controlled power line or directly from the battery. That feature saves power supply costs. TELEFUNKEN introduced this feature as the world first with the 4000 series

**) Depending on the designs different applications need an optical feedback for test purposes or must be quiet (e.g. in Windows CE® applications).

Ordering Information

Part Number	Qty / Reel	Description
TFDU4201-TR1	750	Orientated in carrier tape for side view in mounting
TFDU4201-TR3	2250	Orientated in carrier tape for side view in mounting

Functional Block Diagram

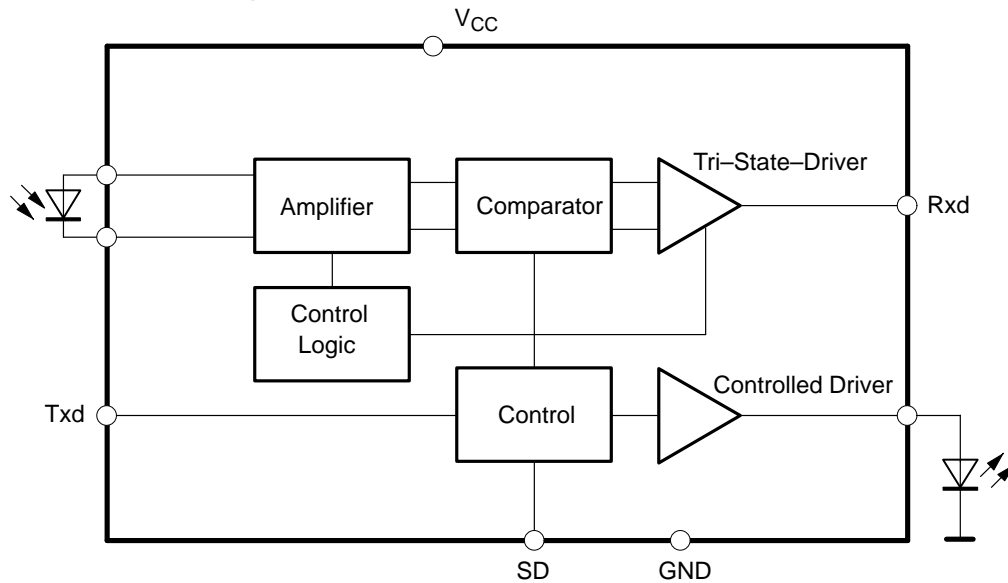

Figure 1. Functional Block Diagram

Pin Description

Pin	Symbol	Description	I/O	Active
1	IRED GND	IRED Cathode, Ground		
2	IRED GND	IRED Cathode, Ground		
3	Rxd	Output, Received Data, tri-state, floating in shutdown mode	O	LOW
4	V _{CC}	Supply Voltage		
5	GND	Ground		
6	GND	Ground		
7	Txd	Input, Transmit data	I	HIGH
8	SD	Shutdown	I	HIGH

Absolute Maximum Ratings

Reference Point Pin 8, unless otherwise noted.

Parameter	Test Conditions	Symbol	Min.	Typ.	Max.	Unit	Remarks
Supply Voltage Range		V_{CC}	-0.5		6	V	
Input Current					10	mA	all pins
Output Sink Current					25	mA	
Power Dissipation		P_{tot}			200	mW	see Figure
Junction Temperature		T_J			125	°C	
Ambient Temperature Range (Operating)		T_{amb}	-25		85	°C	
Storage Temperature Range		T_{stg}	-40		100	°C	
Soldering Temperature	t = 20 s @215°C			215	240	°C	see Vishay Telefunken IrDA Design Guide
Average IRED Current*)		$I_{IRED(DC)}$			125	mA	
Repetitive Pulsed IRED Current*)		$I_{IRED(RP)}$			500	mA	<90 μ s, t_{on} <20%
Transmitter Data Input Voltage		V_{Txd}	-0.5		3.6	V	
Receiver Data Output Voltage		V_{Rxd}	-0.5		$V_{CC}+0.5$	V	
Virtual source size	Method: (1-1/e) encircled energy	d		2		mm	
Compatible to Class 1 operation of IEC 60825 or EN60825 with worst case IrDA SIR pulse pattern, 115.2 kbit/s also in single fault conditions							

*) Note: Maximum values of IRED: Cannot be reached due to implemented current source.



Electrical Characteristics

Tested for the following parameters ($V_{CC} = 2.4\text{ V to }3.6\text{ V}$, 25°C , unless otherwise stated)

Parameter	Test Conditions	Symbol	Min.	Typ.	Max.	Unit	Remarks
Transceiver							
Supported Data Rates	Base band		9.6		115.2	kbit/s	
Supply Voltage Range		V_{CC}	2.4		3.6	V	Operational Down to 2.0 V
Supply Current	$V_{CC} = 2.4\text{ V to }5.5\text{ V}$, $E_e = 0$	I_S		50	80	μA	Receive Mode, full Temperature Range
	$V_{CC} = 2.4\text{ V to }5.5\text{ V}$, 10 klx sunlight	I_S		70	90	μA	
	Shutdown mode $V_{SD} = 0.9 \times V_{CC}$	$I_{S\text{shdown}}$		10 5	100	nA nA	Entire Temperature Range 25°C
IRED Peak Current transmitting	$V_{CC} = 5.5\text{ V}$ $V_{CC} = 2.4\text{ V}$ $V_{CC} = 2.0\text{ V}$	I_{Str}		38 35 31	45 40 35	mA mA mA	SIR Transmit
Transceiver "Power On" Settling Time					50	μs	Time from Switching on V_{CC} to Established Specified Operation

Electrical Characteristics

$V_{CC} = 2.8\text{ V}$, 25°C , unless otherwise stated

Parameter	Test Conditions	Symbol	Min.	Typ.	Max.	Unit	Remarks
Transceiver							
Supply Current	$E_e = 0$	I_S		55	80	μA	Receive Mode, full Temperature Range
	$E_e = 10\text{ klx sunlight}$	I_S		70	90	μA	
	Shutdown mode $V_{SD} = 2.3\text{ V}$, $E_e = 0$, $E_e = 10\text{ klx}$, Standard Illuminant A	$I_{S\text{shdown}}$		10 5 55	100 10	nA nA nA	Entire Temperature Range 25°C
IRED Peak Current transmitting		I_{Str}		30	42	mA	SIR Transmit
Transceiver "Power On" Settling Time					50	μs	Time from Switching on V_{CC} to Established Specified Operation
Logic Input and Output levels							
Input Voltage High	SD, Txd	V_{IH}	2.3			V	
Input Voltage Low	SD, Txd	V_{IL}			0.5	V	
Output Voltage High	Rxd, $I_{OH} = -2\text{ mA}$	V_{OH}	2.3			V	
Output Voltage Low	Rxd, $I_{OL} = 2\text{ mA}$	V_{OL}			0.4	V	

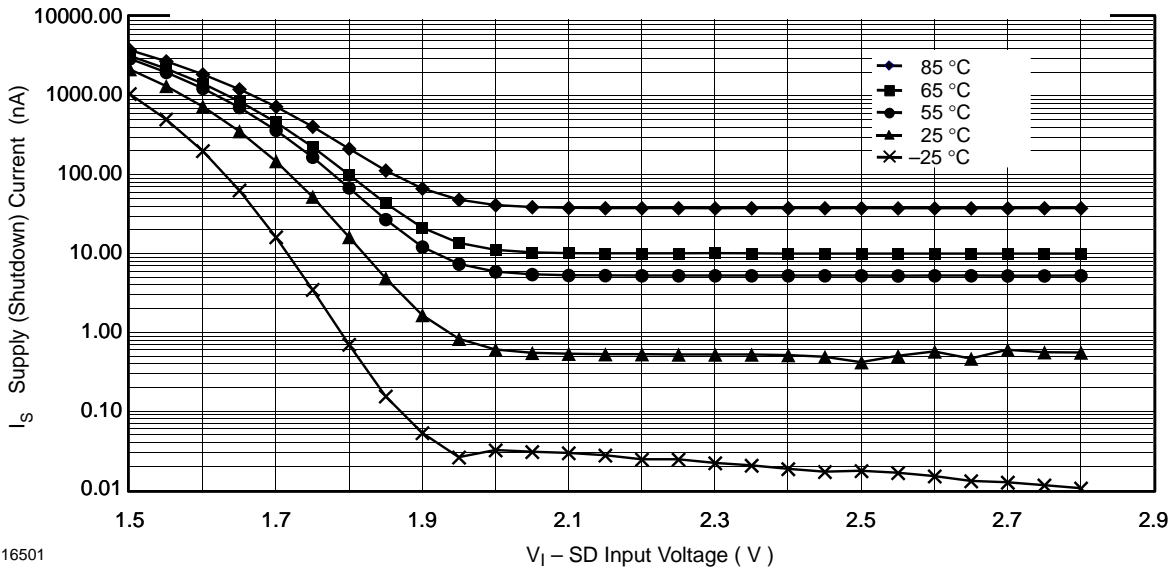

16501

Figure 2. Shutdown Supply Current I_S as a Function of Temperature and Logic Level at SD Input pin (typical device) $V_{CC} = 2.5 V$

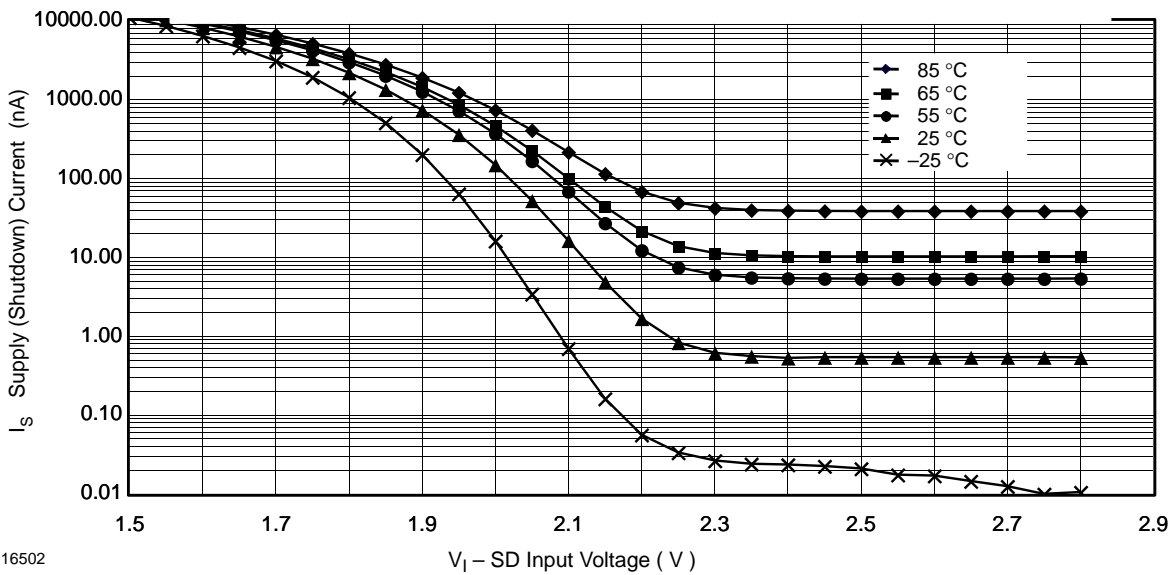

16502

Figure 3. Shutdown Supply Current I_S as a Function of Temperature and Logic Level at SD Input pin (typical device) $V_{CC} = 2.8 V$



Optoelectronic Characteristics

Tested for the following parameters ($V_{CC} = 2.4 \text{ V to } 3.6 \text{ V}$, 25°C , unless otherwise stated)

Parameter	Test Conditions	Symbol	Min.	Typ	Max	Unit	Remarks
Receiver							
Minimum Detection Threshold Irradiance	$ \alpha \leq \pm 15^\circ$ $V_{CC} = 2.0 \text{ V to } 5.5 \text{ V}$	$E_{e, \text{min}}$		25	40	mW/m^2	
Maximum Detection Threshold Irradiance	$ \alpha \leq \pm 90^\circ$ $V_{CC} = 5 \text{ V}$	$E_{e, \text{max}}$	3300	5000		W/m^2	
	$ \alpha \leq \pm 90^\circ$ $V_{CC} = 3 \text{ V}$	$E_{e, \text{max}}$	8000	15000		W/m^2	
Logic Low Receiver Input Irradiance		$E_{e, \text{max, low}}$			4	mW/m^2	
Output Voltage Rxd	Active	V_{OL}		0.5	0.8	V	$C = 15 \text{ pF}$, $R = 2.2 \text{ k}\Omega$
	Non Active	V_{OH}	$V_{CC} - 0.5$			V	$C = 15 \text{ pF}$, $R = 2.2 \text{ k}\Omega$
Output Current Rxd $V_{OL} < 0.8 \text{ V}$					4	mA	
Rise Time @Load: $C = 15 \text{ pF}$, $R = 2.2\text{k}$		t_r	20		200	ns	
Fall Time @Load: $C = 15 \text{ pF}$, $R = 2.2\text{k}$		t_f	20		200	ns	
Rxd Signal Electrical Output Pulse Width	2.4 kbit/s, Input Pulse Width 1.41 μs to 3/16 of bit Duration	t_p	1.4		20	μs	
	115.2 kbit/s, Input Pulse Width 1.41 μs to 3/16 of bit Duration	t_p	1.4		4.5	μs	
Output Delay Time (Rxd), Leading Edge Optical Input to Electrical Output	Output Level = $0.5 \times V_{CC}$ @ 40 mW/m^2	t_{dl}		1	2	μs	
Jitter, Leading Edge of Output Signal	Over a Period of 10 bit, 115.2 kbit/s	t_j			300	ns	
Output Delay Time (Rxd), Trailing Edge Optical Input to Electrical Output	Output Level = $0.5 \times V_{CC}$ 40 mW/m^2	t_{dt}			6.5	μs	
Latency		t_L		100	500	μs	

Optoelectronic Characteristics (continued)

Tested for the following parameters ($V_{CC} = 2.4\text{ V to }3.6\text{ V}$, $-25^{\circ}\text{C to }85^{\circ}\text{C}$, unless otherwise stated)

Parameter	Test Conditions	Symbol	Min.	Typ	Max.	Unit	Remarks
Transmitter							
Logic Low Transmitter Input Voltage		$V_{IL}(\text{Txd})$	0		0.8	V	
Logic High Transmitter Input Voltage		$V_{IH}(\text{Txd})$	2.4		V_{CC}	V	
Controlled Current	$I_e = 5\text{ mW/sr to }70\text{ mW/sr}$ in $ \alpha \leq \pm 15^{\circ}$	I_{F1}	25	30	42	mA	Voltage Range 2.4 V to 5.5 V
Output Radiant Intensity, $ \alpha \leq \pm 15^{\circ}$	$I_{F1} = 25\text{ mA to }42\text{ mA}$	I_e	5	13	70	mW/sr	Current Controlled, 20% duty cycle
Peak Emission Wavelength		λ_p	880		900	nm	
Spectral Emission Bandwidth				60		nm	
Optical Rise/Falltime	115.2 kHz Square Wave Signal (duty cycle 1:1)		1.4		200	ns	
Optical Output Pulse Duration	Input Pulse Duration 1.6 μs			1.6	2.2	μs	
Output Radiant Intensity	Logic Low Level				0.04	$\mu\text{W/sr}$	
Overshoot, Optical					25	%	
Rising Edge Peak to Peak Jitter	Over a Period of 10 bits, Independent of Information Content	t_j			0.2	μs	

Recommended SMD Pad Layout

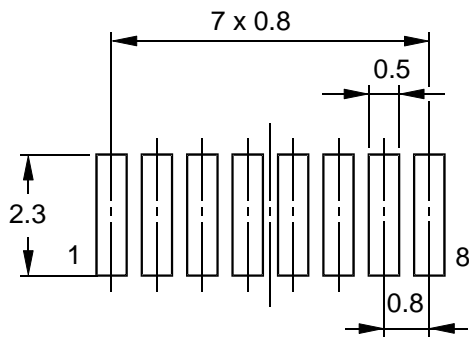

Transceiver leads to be soldered symmetrically on pads

Figure 4. Pad Layout

Current Derating Diagram

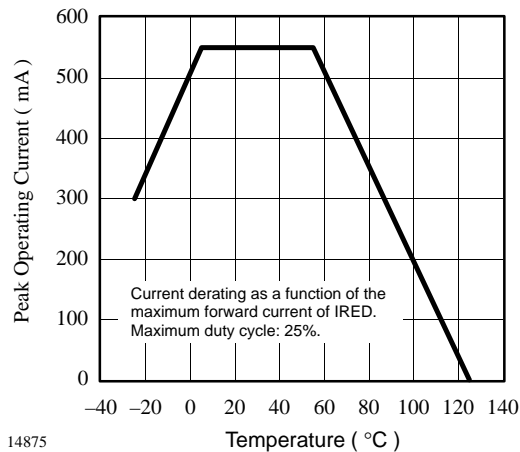
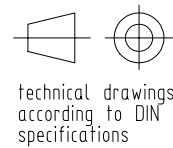
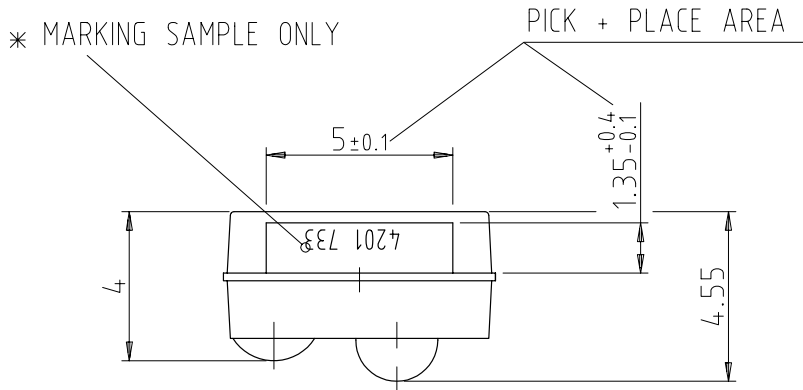
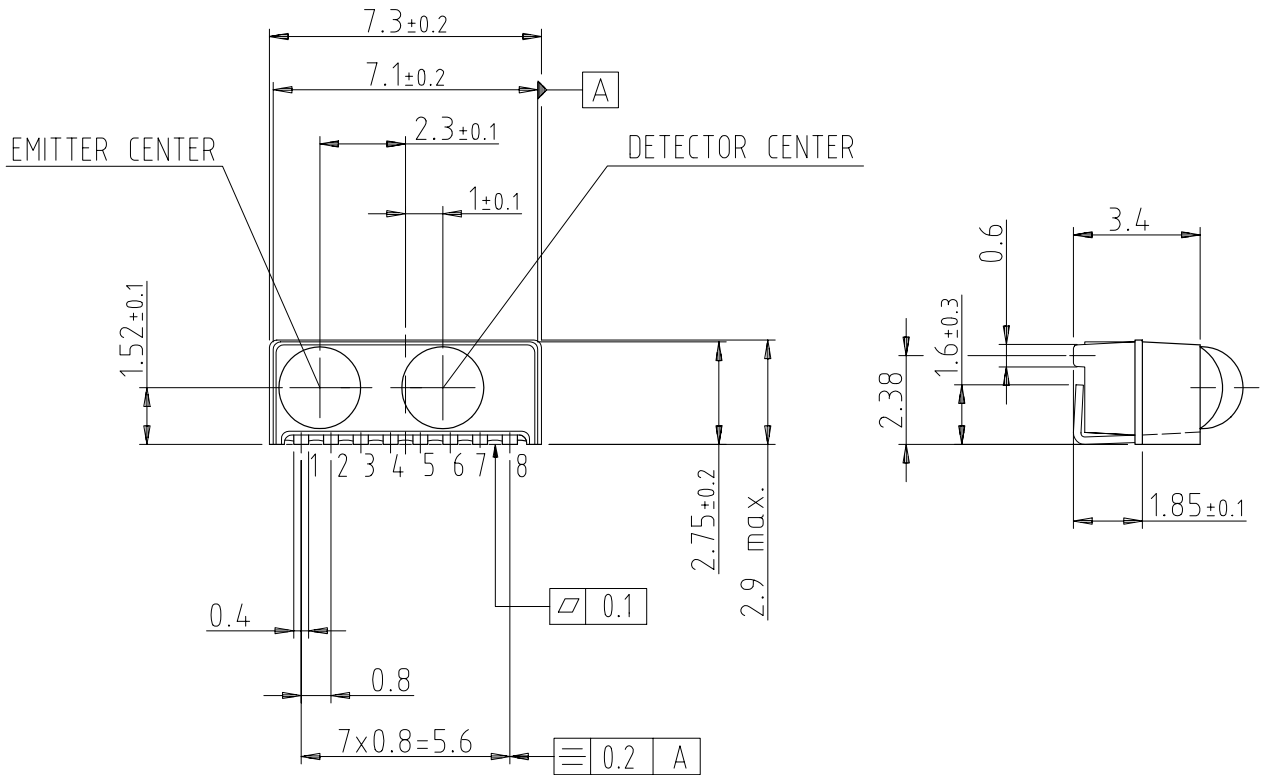

Figure 5. Shows the current derating of the emitter chip as a function of ambient temperature and duty cycle, see absolute maximum ratings. This is for information only. The TFDU4201 has an internal current control. Therefore, most of this curve is not relevant for this device because the higher currents are not intended to be used.

TFDU4201–(Mechanical Dimensions)



* MARKING ORIENTATION
180 DEGREES ALLOWED

14484

Appendix

Application Hints

The TFDU4201 does not need any external component when operated at a “clean” power supply as e.g. two NiCd or NiMH rechargeable batteries in series. In a noisy ambient it is recommended to add a capacitor (and perhaps a resistor) for noise suppression. RF noise picked up from the ambient on the supply lines can be easily suppressed by a 100 nF ceramic capacitor (X7R type is recommended placed close to the V_{CC} pin. Low frequency noise can be suppressed by an RC combination as shown in the schematics. R1 can vary from 0 Ω to 5 Ω . The C1 range is up to 4.7 μ F. During transmission V_{CC} should not drop below the min. power supply voltage. A combination of a tantalum with a ceramics capacitor will be still more efficient in very noisy conditions. However, one should keep in mind a low impedance wiring is more cost efficient than adding larger capacitors.

Shut down

To shut down the TFDU4201 into a standby mode the SD pin has to be set active. For minimizing the shutdown current it is recommended to use a logic high level of $>0.9 \times V_{CC}$

Latency

The receiver is in specified conditions after the defined latency. In a UART related application after that time (typically 50 μ s) the receiver buffer of the UART must be cleared. Therefore the transceiver has to wait at least the specified latency after receiving the last bit before starting the transmission to be sure that the corresponding receiver is in a defined state.

For more application circuits, see IrDC Design Guide and TOIM3...-series data.

Recommended Circuit Diagram

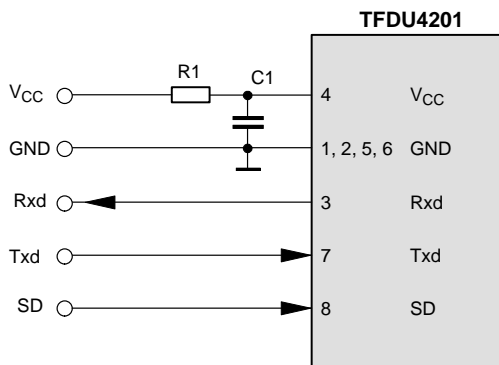

Table 1. Recommended Application Circuit Components *)

Component	Recommended Value	Vishay Part Number
C1	4.7 μ F, 16 V	293D 475X9 016B 2T
R1	5 Ω max	

*) This is a recommendation for a combination to start with to exclude power supply effects. Optimum, from a costs point of view, to work without both.



Revision History:

A1.2, 07/04/1999: New edition

A1.2, 08/07/1999: Correction of typos: 2.4 V instead of 2.7 V in the full context, and missing measurement conditions added.

A1.3, 13/10/2000: Typos corrected

A1.4, 29/01/2001: Typos corrected, storage temperature increased, IRED peak current increased, minimum detection threshold improved, latency increased, output radiation intensity, improved.

Ozone Depleting Substances Policy Statement

It is the policy of **Vishay Semiconductor GmbH** to

1. Meet all present and future national and international statutory requirements.
2. Regularly and continuously improve the performance of our products, processes, distribution and operating systems with respect to their impact on the health and safety of our employees and the public, as well as their impact on the environment.

It is particular concern to control or eliminate releases of those substances into the atmosphere which are known as ozone depleting substances (ODSs).

The Montreal Protocol (1987) and its London Amendments (1990) intend to severely restrict the use of ODSs and forbid their use within the next ten years. Various national and international initiatives are pressing for an earlier ban on these substances.

Vishay Semiconductor GmbH has been able to use its policy of continuous improvements to eliminate the use of ODSs listed in the following documents.

1. Annex A, B and list of transitional substances of the Montreal Protocol and the London Amendments respectively
2. Class I and II ozone depleting substances in the Clean Air Act Amendments of 1990 by the Environmental Protection Agency (EPA) in the USA
3. Council Decision 88/540/EEC and 91/690/EEC Annex A, B and C (transitional substances) respectively.

Vishay Semiconductor GmbH can certify that our semiconductors are not manufactured with ozone depleting substances and do not contain such substances.

We reserve the right to make changes to improve technical design and may do so without further notice.

Parameters can vary in different applications. All operating parameters must be validated for each customer application by the customer. Should the buyer use Vishay Telefunken products for any unintended or unauthorized application, the buyer shall indemnify Vishay Telefunken against all claims, costs, damages, and expenses, arising out of, directly or indirectly, any claim of personal damage, injury or death associated with such unintended or unauthorized use.

Vishay Semiconductor GmbH, P.O.B. 3535, D-74025 Heilbronn, Germany
Telephone: 49 (0)7131 67 2831, Fax number: 49 (0)7131 67 2423