

***THIS DOCUMENT IS FOR MAINTENANCE
PURPOSES ONLY AND IS NOT
RECOMMENDED FOR NEW DESIGNS***

SL6609

DIRECT CONVERSION FSK DATA RECEIVER

This device is an advanced direct conversion receiver for operation up to 470MHz. The device integrates all functions to translate a binary FSK modulated RF signal into a demodulated data stream. Adjacent channel rejection is provided using tuneable gyrator filters. To assist operation in the presence of large interfering signals both RF and audio AGC functions are provided.

The device also includes a 1 volt regulator capable of sourcing up to 5mA, a battery flag and the facility of incorporating a more complex post detection filter off-chip. Both battery flag and data outputs have open collector outputs to ease their interface with other devices.

FEATURES

- Very low power operation - typ 3.0mW
- Single cell operation for most of the device.
- Limited functional blocks operating via an inverter
- Superior sensitivity of -130dBm
- Operation at wide range of paging data rates 512, 1200, 2400 baud
- On chip 1 volt regulator
- Small package offering SSOP

APPLICATIONS

- Credit card pagers
- Watch pagers
- Small form factor pagers i.e. PCMCIA
- Low data rate data receivers i.e. Security/remote control

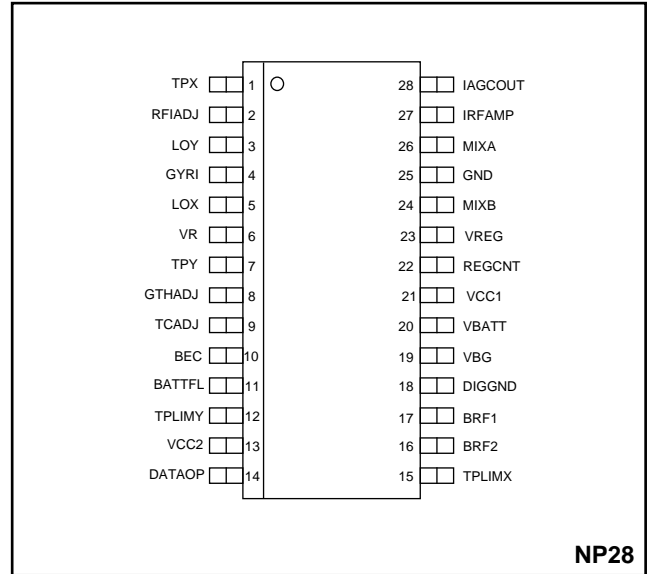

Fig.1 Pin connections

ABSOLUTE MAXIMUM RATINGS

Supply voltage	6V
Storage temperature	-55°C to +150°C
Operating temperature	-20°C to +70°C

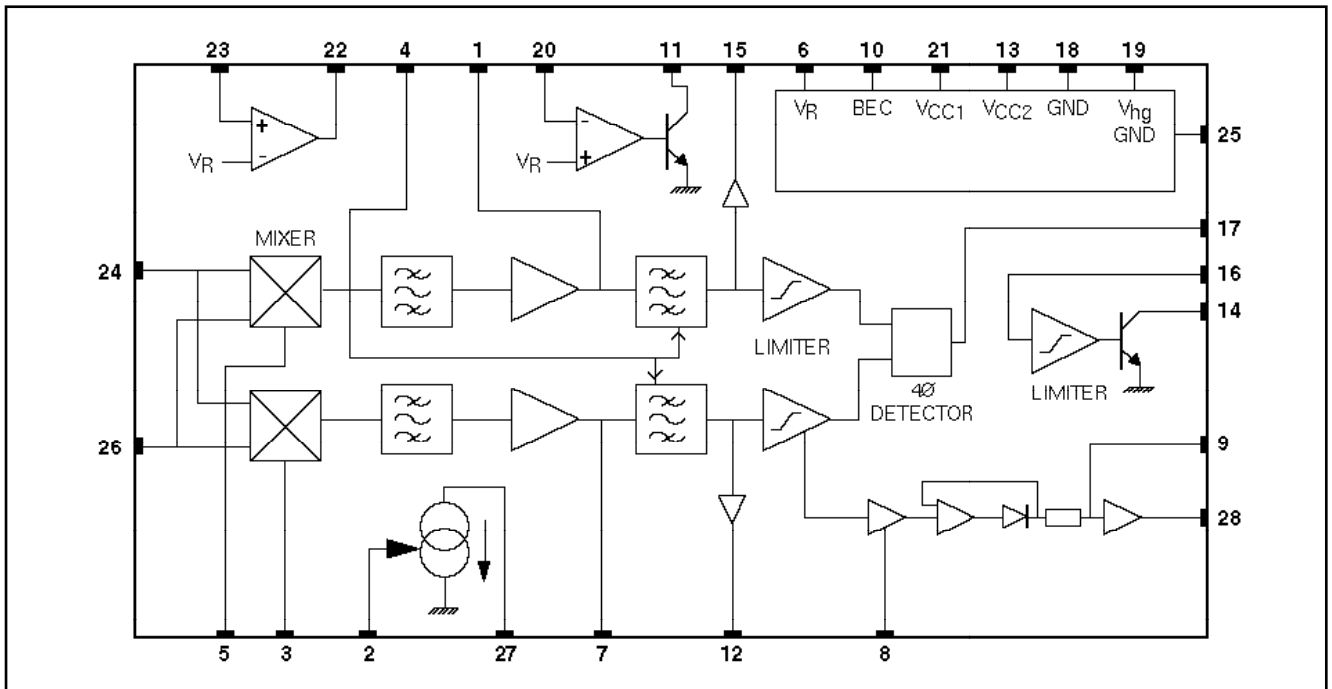

Fig.2 Block diagram of SL6609

SL6609

ELECTRICAL CHARACTERISTICS

These characteristics are guaranteed over the following conditions unless otherwise stated:

Tamb = 25°C, VCC1 = 1.3V, VCC2 = 2.7V

Characteristics	Pin	Value			Units	Comments
		Min	Typ	Max		
VCC1 - Supply voltage	21	0.95	1.3	2.8	V	VCC1 ≤ VCC2 - 0.7 volts
VCC2 - Supply voltage	13	1.8	2.7	3.5	V	
ICC1 - Supply current	21,27,28		1.5	1.8	mA	Includes 500µA IRF. Does not include regulator supply. Audio AGC inactive Batt flag & Data O/P high Pin 27 voltage: 0.3 - 1.3V
ICC2 - Supply current	11,13,14		550	700	µA	
Power down ICC1	21,27,28			1	µA	
Power down ICC2	11,13,14			8	µA	
1 volt regulator	23	0.95	1.0	1.05	V	I Load = 3mA. Ext PNP. β = 100, V _{CE} = 0.1 volt
Band gap voltage reference	19	1.15	1.21	1.27	V	VCC1 > 1.1V
Band gap current source	19			20	µA	
Voltage reference	6	0.93	1.0	1.07	V	
Voltage reference sink/source	6			10	µA	
1 volt regulator load current		0.25	3	5	mA	
Turn on Time			5		mS	Stable data o/p when 3dB above sensitivity. C _{BG} and C _{VR} = 2.2µF
Turn off Time			1		mS	Fall to 10% of steady state current C _{BG} and C _{VR} = 2.2µF
Detector output current	17		+/-4		µA	
RF current source						
Current Source (RFAMP)	27	450	520	600	µA	Pin 27 voltage: 0.3 - 1.3V
Decoder						
Sensitivity		40			µVrms	Signal injected at TPX and TPY B.E.R. ≤ 1 in 30 5KHz deviation @ 500 bits/sec BRF capacitor = 2nF
Output mark space ratio	14	7:9		9:7		
Data O/P Sink Current	14	100		500	µA	Output logic low
Data O/P Leakage Current	14			1.0	µA	Output logic high

ELECTRICAL CHARACTERISTICS

These characteristics are guaranteed over the following conditions unless otherwise stated:

Tamb = 25°C, VCC1 = 1.3V, VCC2 = 2.7V

Characteristics	Pin	Value			Units	Comments
		Min	Typ	Max		
Battery Economy						
Input logic high	10	(V _{CC2} - 0.3)			V	Powered Up
Input logic low	10			0.3	V	Powered Down
Input current	10		0.05	1	µA	Powered Up
Input current	10		6	8	µA	Powered down transient initial
Battery Flag Input						
Input current	20			1	µA	
Battery Flag Output						
Battfl Sink Current	11	100		500	µA	(VBATT-VR) > 20mV
Battfl leakage current	11			1	µA	(VBATT-VR) < -20mV
Mixers						
Gain to "IF Test"		34		41	dB	LO inputs driven in parallel with 50mVRMS @ 50MHZ. IF = 2KHz
RF input impedance	24, 26					See Figs.8a, 8b
LO input impedance	3, 5					See Fig.9
LO DC bias voltage	3, 5				V	Equal to Pin 21 (VCC1)
Audio AGC						
Max Audio AGC Sink Current	28	45	65	85	µA	

RECEIVER CHARACTERISTICS (GPS Demonstration board)

Measurement conditions unless stated V_{CC1} = 1.3V, V_{CC2} = 2.7V, LNA = 18dB Gain, 2dB Noise figure,

Carrier frequency 153MHz, BER 1 in 30, Tamb = 25°C

Characteristics	Pin	Value			Units	Comments
		Min	Typ	Max		
Sensitivity		-130	-127.5	-125	dBm	512 bps f = 4.5kHz LO = -18dBm
		-128	-125.5	-123	dBm	1200 bps f = 4kHz LO = -18dBm
Intermodulation		54	55		dB	512 bps f = 4.5kHz LO = -18dBm
Adjacent channel		68	72.5		dB	512 bps f = 4.5kHz LO = -18dBm Channel spacing 25kHz
Centre frequency acceptance		+/- 2.0	+/- 2.5 +/-2		kHz	512 bps f = 4.5kHz
					kHz	1200 bps f = 4kHz LO = -18dBm
Deviation acceptance			+/- 2.5 +/-2		kHz	512 bps f = 4.5kHz
					kHz	1200 bps f = 4kHz LO = -18dBm

SL6609

RECEIVER CHARACTERISTICS (GPS Demonstration board)

Measurement conditions unless stated $V_{CC1} = 1.3V$, $V_{CC2} = 2.7V$, LNA = 18dB Gain, 2dB Noise figure,
Carrier frequency 282MHz, BER 1 in 30, Tamb = 25°C

Characteristics	Pin	Value			Units	Comments
		Min	Typ	Max		
Sensitivity		-130	-128.5	-125	dBm	512 bps f = 4.5kHz LO = -15dBm
		-128	-126	-123	dBm	1200 bps f = 4.0kHz LO = -15dBm
Intermodulation		54	55.5		dB	512 bps f = 4.5kHz LO = -15dBm
Adjacent channel		68	72		dB	512 bps f = 4.5kHz LO = -15dBm Channel spacing 25kHz
Centre frequency acceptance		+/- 2.0	+/- 2.5 +/-2		kHz kHz	512 bps f = 4.5kHz 1200 bps f = 4kHz LO = -15dBm
Deviation acceptance			+/- 2.5 +/-2		kHz kHz	512 bps f = 4.5kHz 1200 bps f = 4kHz LO = -15dBm

RECEIVER CHARACTERISTICS

Measurement conditions unless stated $V_{CC1} = 1.3V$, $V_{CC2} = 2.7V$, LNA = 18dB Gain, 2dB Noise figure,
Carrier frequency 470MHz, BER 1 in 30, Tamb = 25°C

Characteristics	Pin	Value			Units	Comments
		Min	Typ	Max		
Sensitivity		-127	-125	-122	dBm	1200 bps f = 4kHz LO = -15dBm
Intermodulation		50	53		dB	1200 bps f = 4kHz LO = -15dBm
Adjacent channel		65	70		dB	1200 bps f = 4kHz LO = -15dBm Channel spacing 25kHz
Centre frequency acceptance			+/- 2		kHz	1200 bps f = 4kHz LO = -15dBm
Deviation acceptance			+/- 2		kHz	1200 bps f = 4kHz LO = -15dBm

OPERATION OF SL6609

The SL6609 is a Direct Conversion Receiver designed for use up to 470MHz. It is available in a 28 pin SSOP package and it integrates all the facilities required for the conversion of an RF FSK signal to a base-band data signal.

Low Noise Amplifier

To achieve optimum performance it is necessary to incorporate a Low Noise RF Amplifier at the front end of the receiver. This is easily biased using the on chip voltage and current sources provided.

All voltages and current sources used for bias of the RF amplifier, receiver and mixers should be RF decoupled using suitable capacitors (see fig.4 for a suitable Low-Noise-Amplifier).

Local Oscillator

The Local Oscillator signal is applied to the device in phase quadrature. This can be achieved with the use of two RC networks operating at the -3dB/45° transfer characteristic, giving a full 90° phase differential between the LO ports of the device. Each LO port of the device also requires an equal level of drive from the Oscillator. (see Fig.5).

Gyrator Filters

The on chip filters include an adjustable gyrator filter. This may be adjusted with the use of an additional resistor between pin 4 and GND. This allows flexibility of filter characteristics and also allows for compensation for possible process variations.

Audio AGC

The Audio AGC fundamentally consists of a current sink which is controlled by the audio (baseband data) signal. It has three parameters that may be controlled by the user. These are the Attack (turn on) time, Decay (duration) time and Threshold level (see Fig.6 and 7). See Application note for details.

Regulator

The on chip regulator must be used in conjunction with a suitable PNP transistor to achieve regulation. As the transistor forms part of the regulator feedback loop the transistor should exhibit the following characteristics:-

$$H_{FE} > = 100 \text{ for } V_{CE} > = 0.1V$$

Pin Number	Pin Name	Pin Description
1	TPX	X channel pre-gyrator filter test-point. This can be used for input and output
2	RFIADJ	RF current source adjustment pin
3	LOY	LO input channel Y
4	GYRI	Gyrator current adjust pin
5	LOX	LO input channel X
6	VR	VREF 1.0 V internal signal ground
7	TPY	Y channel pre-gyrator filter test point, input or output
8	GTHADJ	Audio AGC gain and threshold adjust. RSSI signal indicator
9	TCADJ	Audio AGC time constant adjust
10	BEC	Battery economy control
11	BATTFL	Battery flag output
12	TPLIMY	Y channel limiter (post gyrator filter) test point, output only
13	VCC2	Supply connection
14	DATAOP	Data output pin
15	TPLIMX	X channel limiter (post gyrator filter) test point, output only
16	BRF2	Bit rate filter 2, input to data output stage
17	BRF1	Bit rate filter 1, output from detector
18	DIG GND	Digital ground
19	VBG	Bandgap voltage output
20	VBATT	Battery flag input voltage
21	VCC1	Supply connection
22	REGCNT	1V regulator control external PNP drive
23	VREG	1V regulator output voltage
24	MIXB	Mixer input B
25	GND	Ground
26	MIXA	Mixer input A
27	IRFAMP	Current source for external LNA. Value of current output will decrease at high mixer input signal levels due to RF AGC
28	IAGCOUT	Audio AGC output current

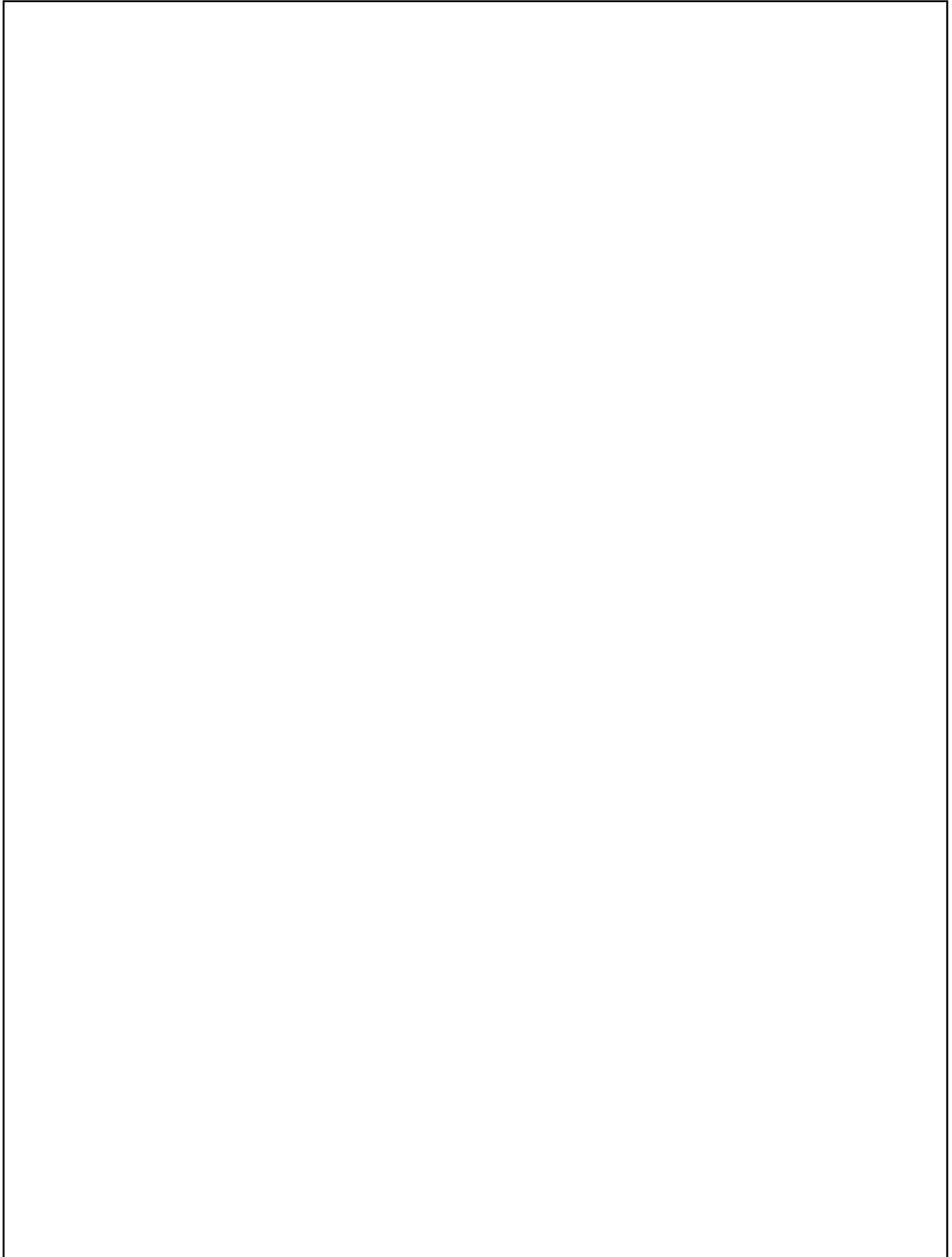

Fig.3 Application circuit board

COMPONENTS LIST FOR APPLICATION BOARD At 282MHz, 25kHz Channel Spacing.**Resistors**

R1	open circuit
R2	open circuit
R3	220
R4	100k
R5	1k
R6	1k
R7	220
R8	open circuit
R9	220k
R10	1M
R11	100k ⁽⁶⁾
R12	not used
R13	2k7
R14	4k7
R15	4k7
R16	33k
R17	not used ⁽³⁾
R18	0R ⁽³⁾
R19	10k
R20	680
R21	1k
R22	open circuit

Capacitors

C1	1n
C2	2p7
C3	4p7
C4	1n
C5	2p7
C6	2u2
C7	1n
C8	100n
C9	1n ⁽²⁾
C10	2u2
C11	100n
C12	1n
C13	1n
C14	1n
C15	1n
C16	1n
C17	1n
C17a	1n

Notes

1. The values of R13 is determined by the set-up procedure. See Application Note.
2. The value of C9 is determined by the output data rate. Use 2nF for 512bps, 1nF for 1200bps and 470pF for 2400bps.
3. R17 (See figure.6) forms a part of the audio AGC circuit and is determined by the voltage drop required to make the diode D1, conduct to give the RF attenuation required. R17 should be sufficiently large to ensure the voltage at pin 28 does not drop below 200mV. The maximum AGC current expected is 85µA. For the characteristics of the audio AGC current source see figure 7. If the audio AGC is not required then the current source (Pin 28) may be disabled by connecting Pin 9 (TCADJ) to VR (pin 6) and by connecting Pin 28

C18	1n
C19	not used
C20	1n
C21	1n
C22	not used
C23	1n
C24	1n
C25	1n
C26	5p6 ⁽⁴⁾
C27	1n
C28	1n
C29	100p
C30	2u2
C31	2u2
C32	4p7
C33	4p7
C34	3p3
C35	not used
VC1	1-10p
VC2	1-10p
VC3	1-10p

Inductors

L1	100n ⁽⁴⁾
L2	not used
L3	470n
L4	39n
L5	680n

Active Components

Q1	FMMT589
Q2	BFT25A
Q3	BFT25A
Q4	not used
Q5	BFT25A
D1	Panasonic MA862 ⁽⁵⁾

Misc

T1	30nH 1:1 Coilcraft M1686-A
Xtal	5th Overtone 94.075MHz

(IAGCOUT) to Vcc1., (R18). The voltage at Pin 8 may still be used as an RSSI. R9, C8, C14, C19, R17 and D1 may then be omitted. See figure.6 for AGC component values.

4. L1 and C26 form the low noise matching network for the RF amplifier. The values given are for the RF amplifier specified in the Applications Circuit with no Audio AGC connected. i.e. R17 and D1 omitted.
5. Suggested diode for use with the Audio AGC circuit (see figure.6) (D1 is not included on the general demonstration circuit).
6. The value of R11 is dependent on the data output load. R11 should allow sufficient current to drive the data output load.

SL6609

COMPONENTS LIST FOR APPLICATION BOARD At 470MHz, 25kHz Channel Spacing.
(LO circuit is 50 network as in Fig.5 - crystal oscillator not specified)

Resistors

R1	open circuit	C14	1n
R2	open circuit	C15	1n
R3	100	C16	1n
R4	100k	C17	1n
R5	100	C18	1n
R6	100	C19	not used
R7	100	C20	1n
R8	open circuit	C21	1n
R9	220k	C22	not used
R10	1M	C23	not used
R11	100k ⁽²⁾	C24	1n
R12	300 ⁽³⁾	C25	1n
R13	open circuit ⁽¹⁾	C26	2.2pF ⁽⁵⁾
R14	4k7	C27	not used
R15	4k7	C28	not used
R16	33k	C29	100p
R17	open circuit ⁽⁴⁾	C30	2u2
R18	0R ⁽⁴⁾	C31	2u2
R22	open circuit	C34	not used
		VC1	1-3pF

Capacitors

C1	1n
C2	3.3pF
C3	1n
C4	1n
C5	3.9pF
C6	2u2
C7	1n
C8	100n
C9	1n ⁽²⁾
C10	2u2
C11	100n
C12	1n
C13	1n

Inductors

L1	39nH ⁽⁵⁾
L2	short circuit
T1	18nH 2 Turn 1:1 (Coilcraft) Q4123-A

Active Components

Q1	Zetex FM589
Q2	Philips BFT25A
Q3	Not Used
Q4	Philips BFT25A ⁽³⁾
Q5	Philips BFT25A
D1	Panasonic MA862 ⁽⁶⁾

Notes

1. The values of R13 is determined by the set-up procedure. See Application Note.
2. The value of "C9" is determined by the output data rate. Use 2nF for 512bps, 1nF for 1200bps and 470pF for 2400bps.
3. R12 & Q4 form a dummy load for the regulator. Permitted load currents for the regulator are 250µA to 5mA. The 1V regulator (output pin 23) can be switched off by connecting pin 23 directly to VCC2. Q1, Q4, R12 and C12 must then be omitted
4. R17 forms a part of the audio AGC circuit (see figure 6) and is determined by the voltage drop required to make the PIN diode D1, conduct to give the RF attenuation required. R17 should be sufficiently large to ensure the voltage at pin 28 does not drop below 200mV. The maximum AGC current expected is 85µA. For the characteristics of the audio AGC current source see figure 7. If the audio AGC is not required then the current source (Pin 28) may be disabled by connecting Pin 9 (TCADJ) to VR (pin 6) and by connecting Pin 28 (IAGCOUT) to Vcc1., (R18). The voltage at Pin 8 may still be used as an RSSI. R9, C8, C14, C19, R17 and D1 may then be omitted.
5. L1and C26 form the low noise matching network for the RF amplifier. The values given are for the RF amplifier specified in the Applications Circuit with no Audio AGC connected. i.e. R17 and D1 omitted.
6. Suggested diode for use with the Audio AGC circuit (D1 is not included on the general demonstration circuit).
7. The value of R11 is dependent on the data output load. R11 should allow sufficient current to drive the data output load.

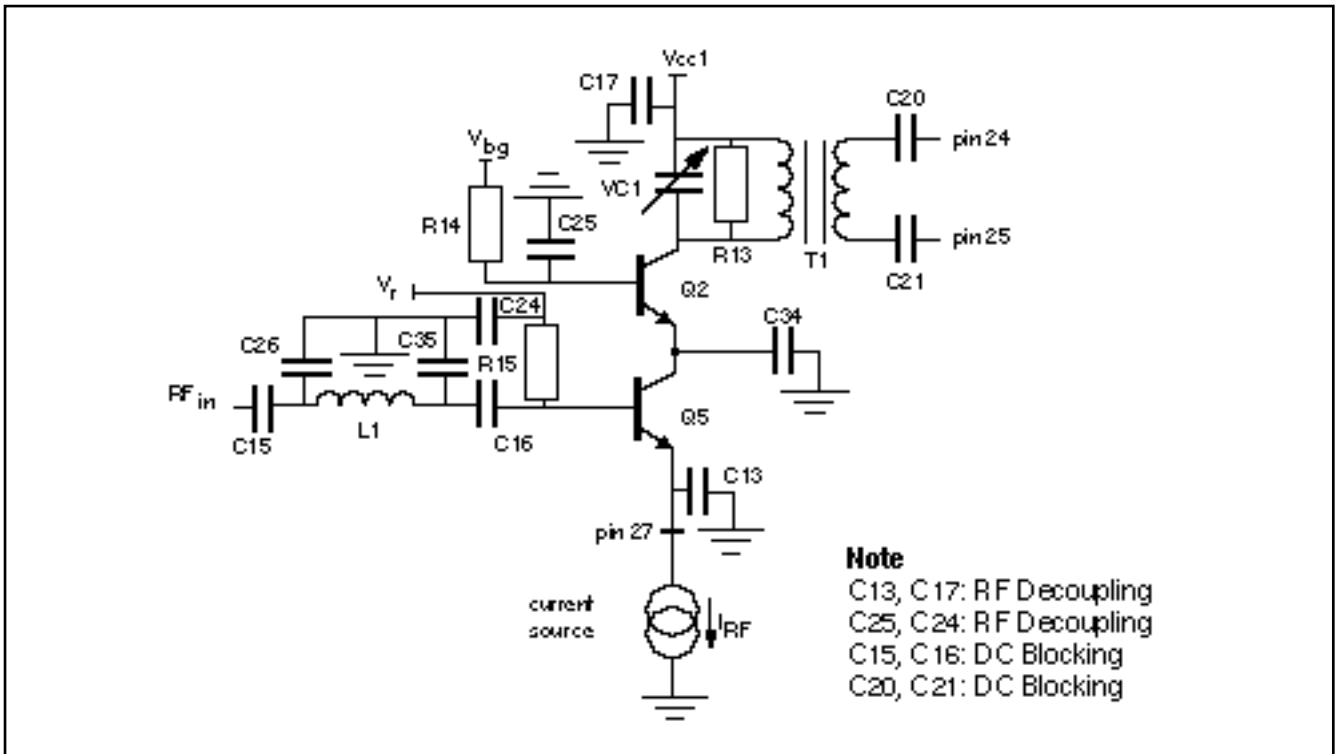

Fig.4 RF Amplifier

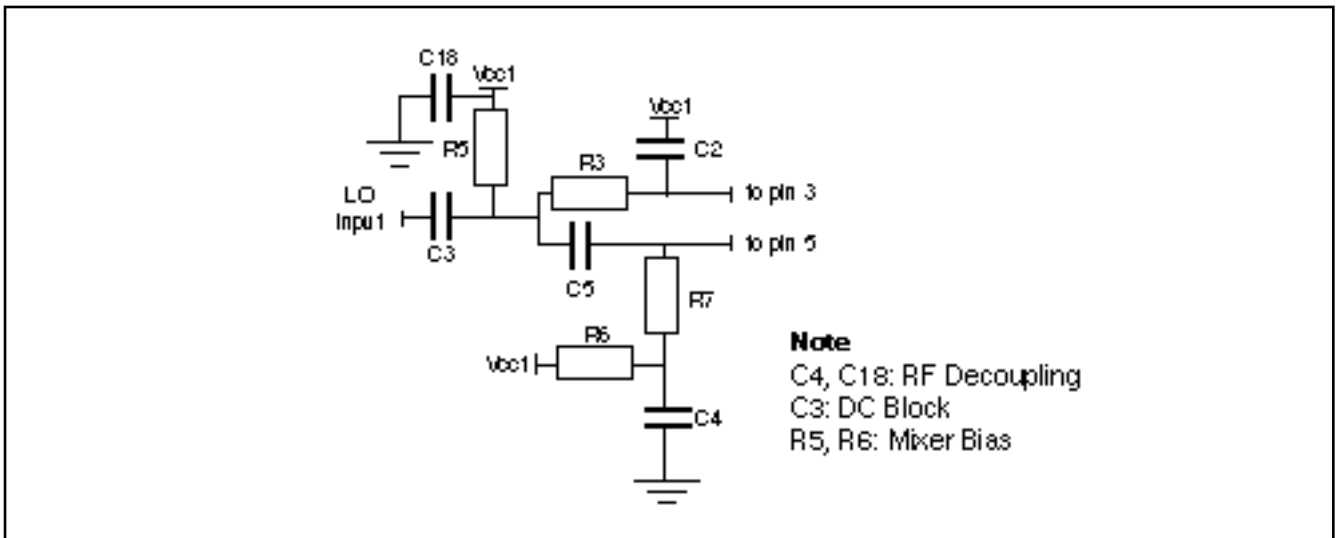

Fig.5 LO Network

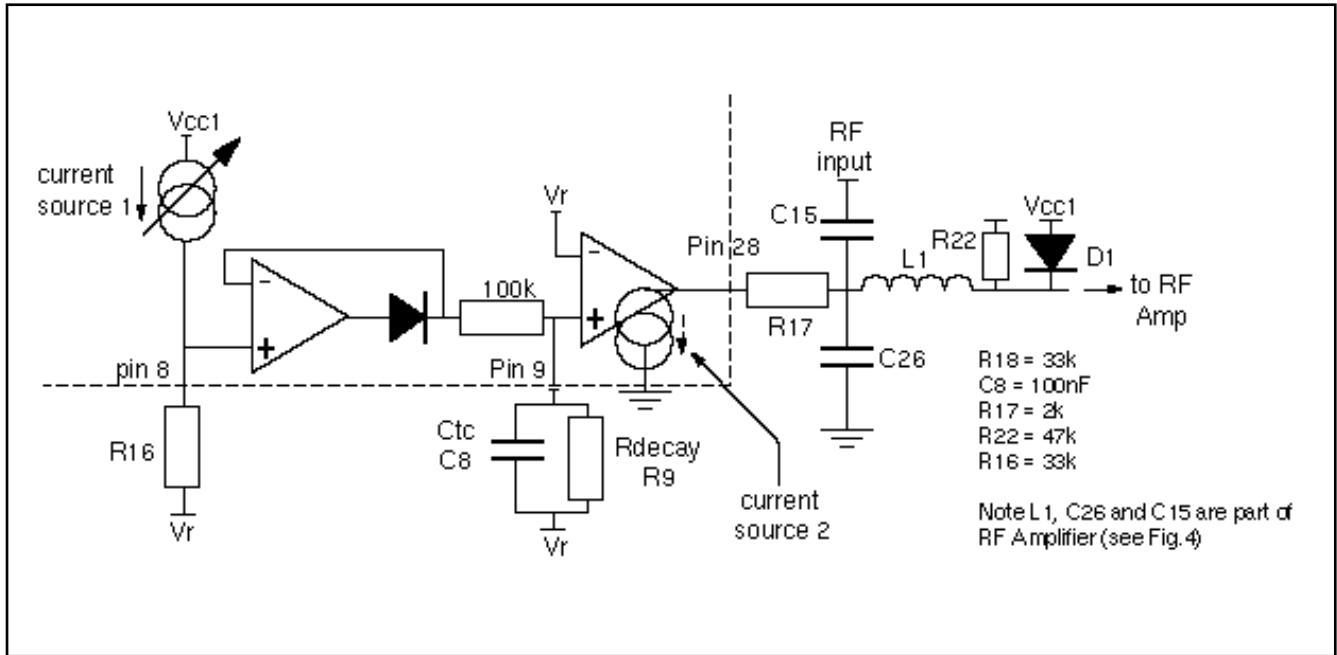

Fig.6 AGC Schematic

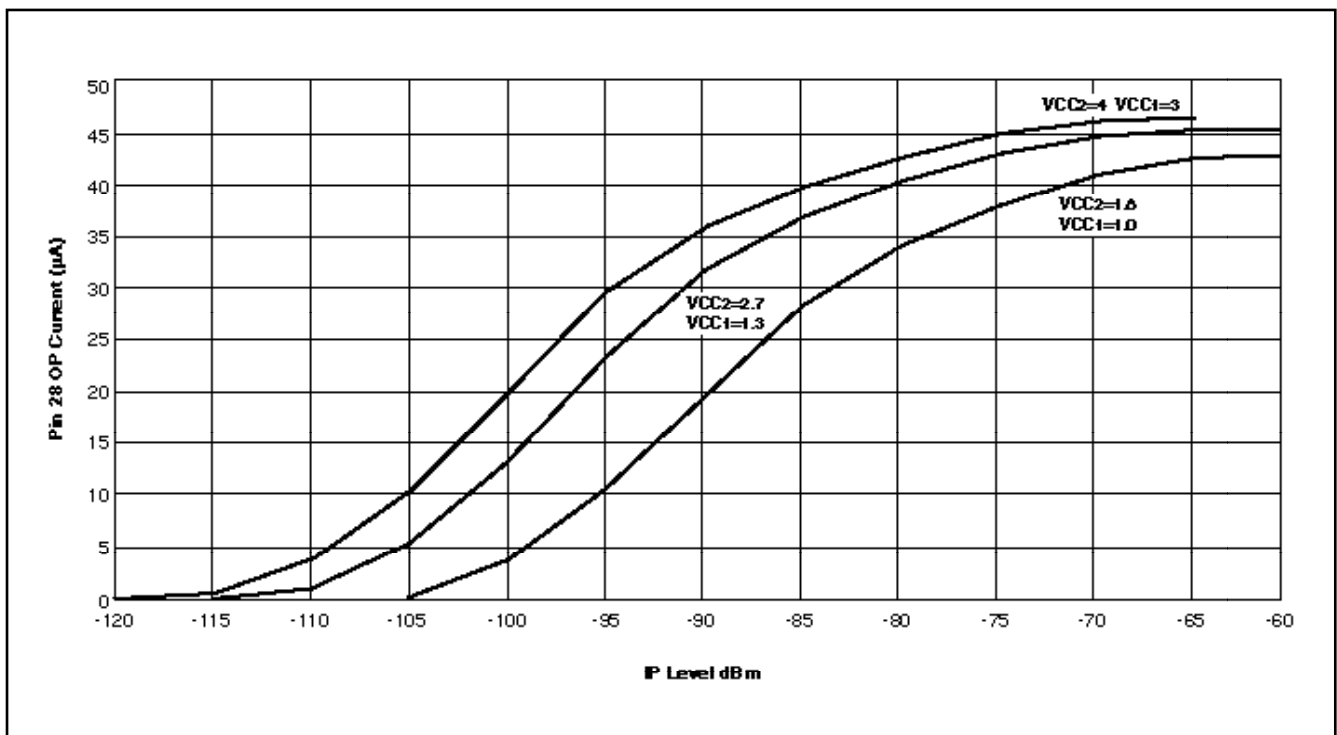

Fig.7 Audio AGC current vs. IP power at 25°C

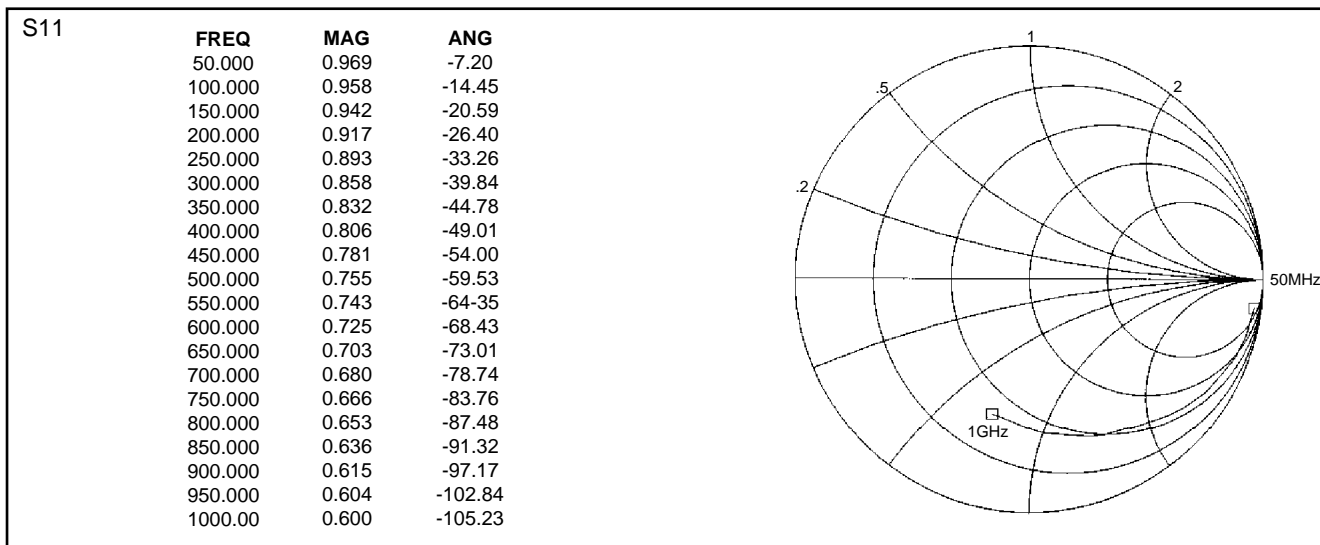

Fig.8a SL6609 Mixer A input S-Parameters

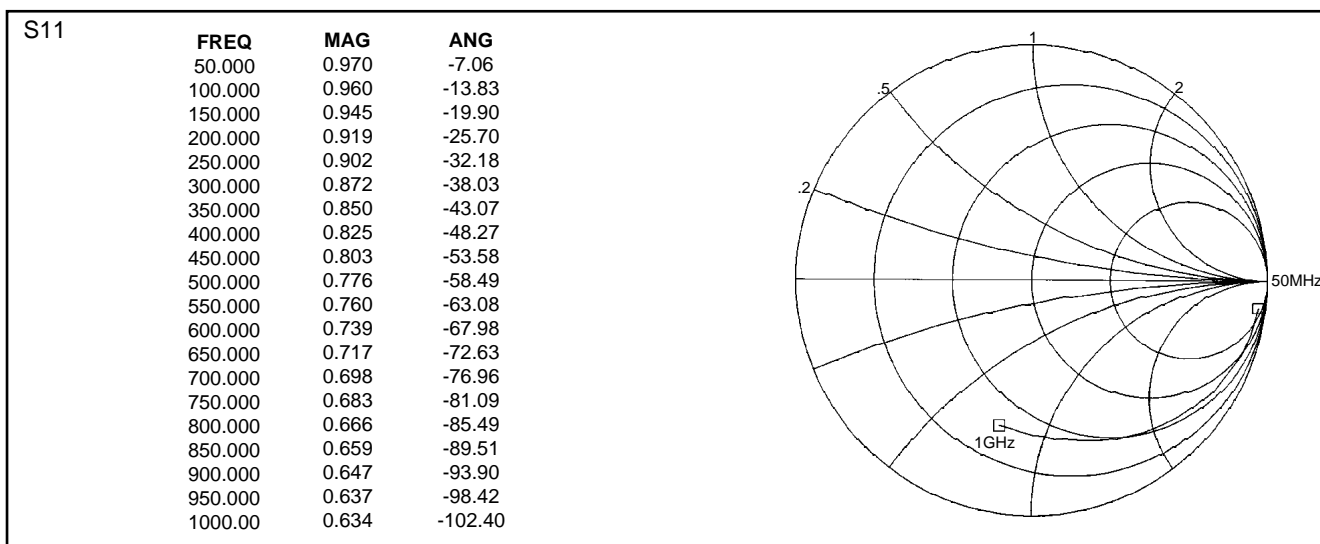

Fig.8b SL6609 Mixer B input S-Parameters

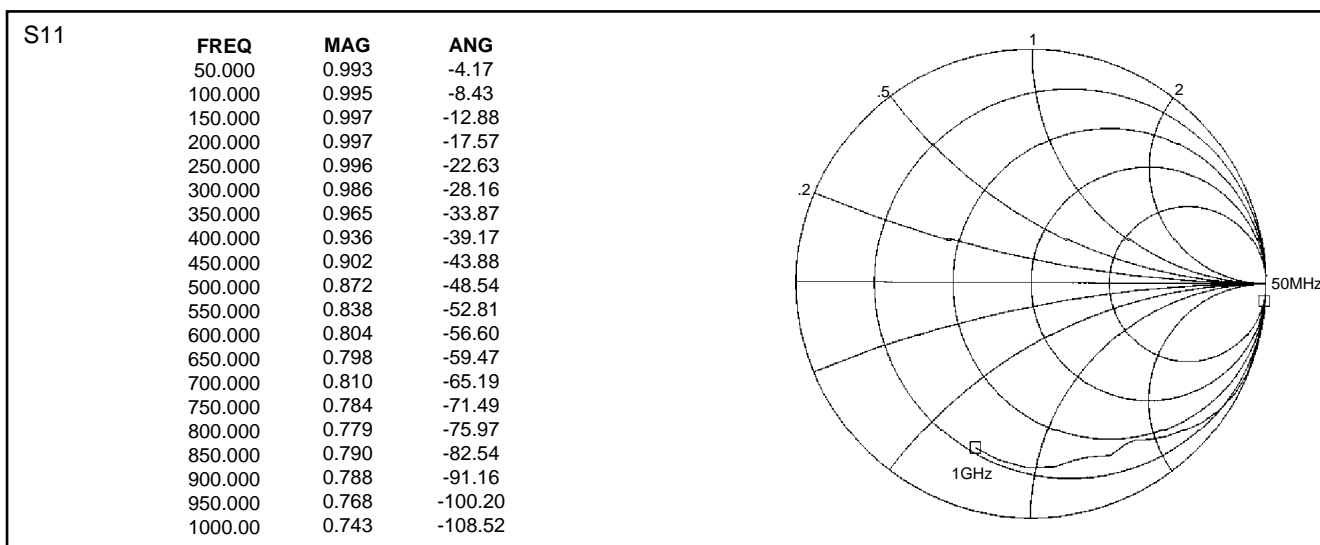

Fig.9 SL6609 LO X,Y inputs S-Parameters

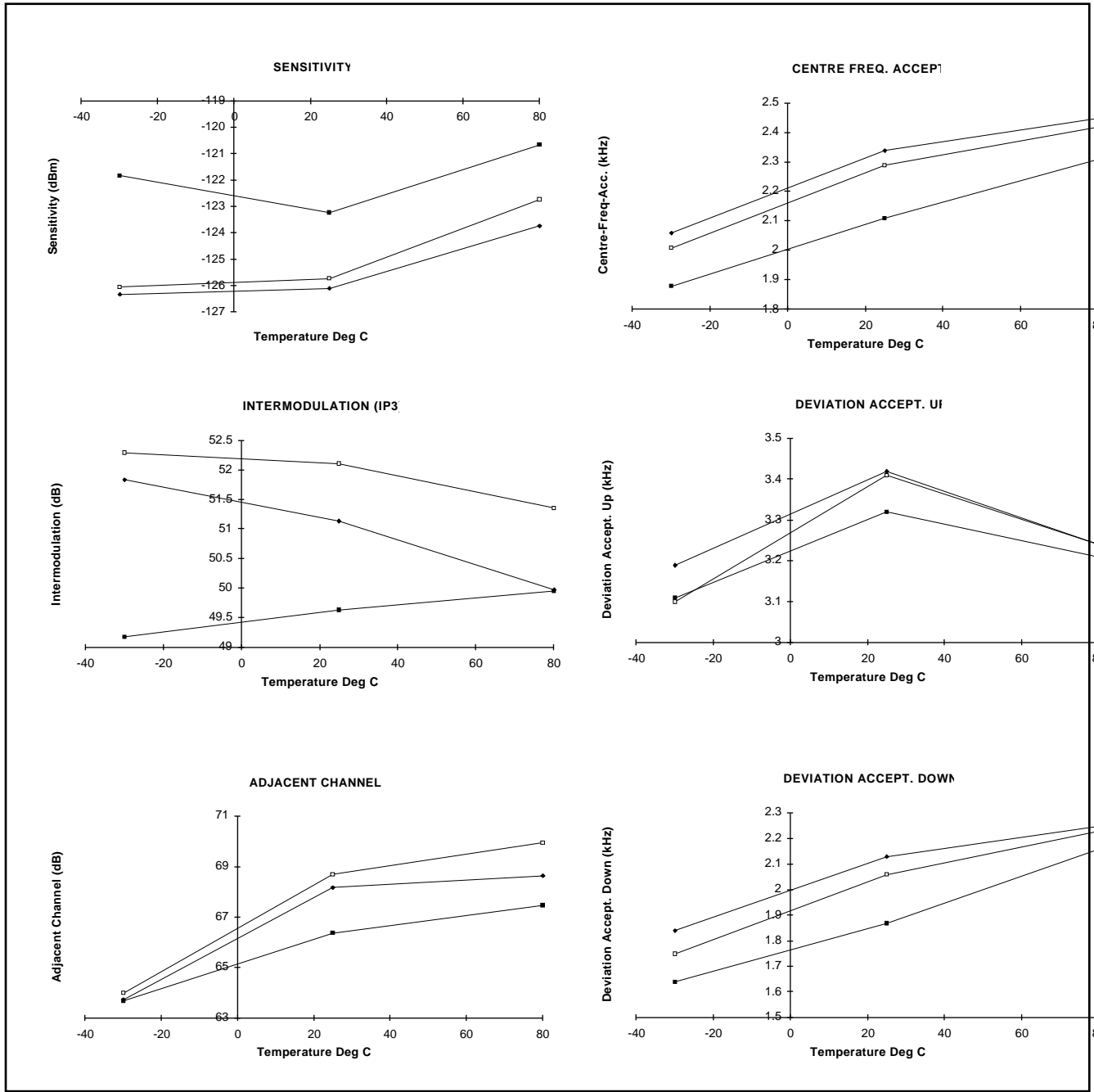
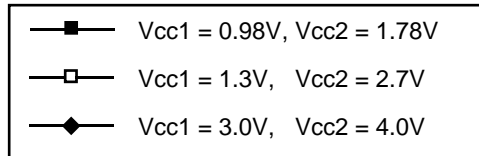

Fig.10 AC parameters vs. supply and temperature

Conditions:- 282MHz GPS demonstration board i.e. 18dB LNA, 2dB noise figure, carrier frequency 282MHz, 1200bps baud rate, 4kHz deviation frequency BER 1 in 30.



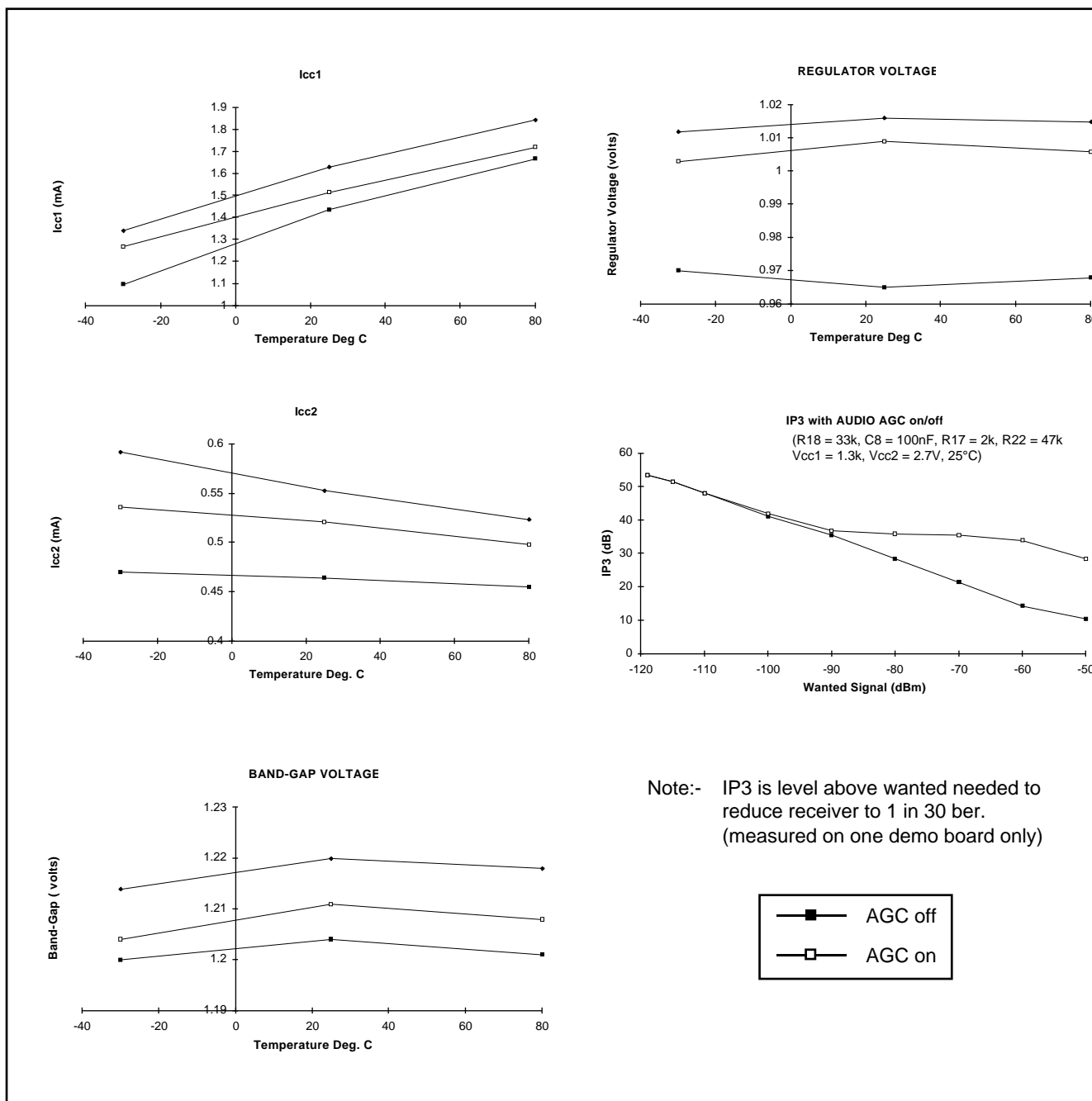
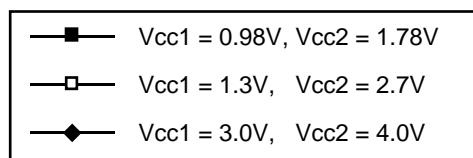

Fig.11 DC parameters vs. supply and temperature (IP3 vs audio AGC both on and off)

Conditions:- ICC1 includes 500µA LNA current but does not include the regulator supply (audio AGC inactive). ICC2 measured with BATT FLAG and DATA O/P HIGH, Fc = 282MHz.



SL6609

SL6609

PACKAGE DETAILS

Dimensions are shown thus: mm (in)

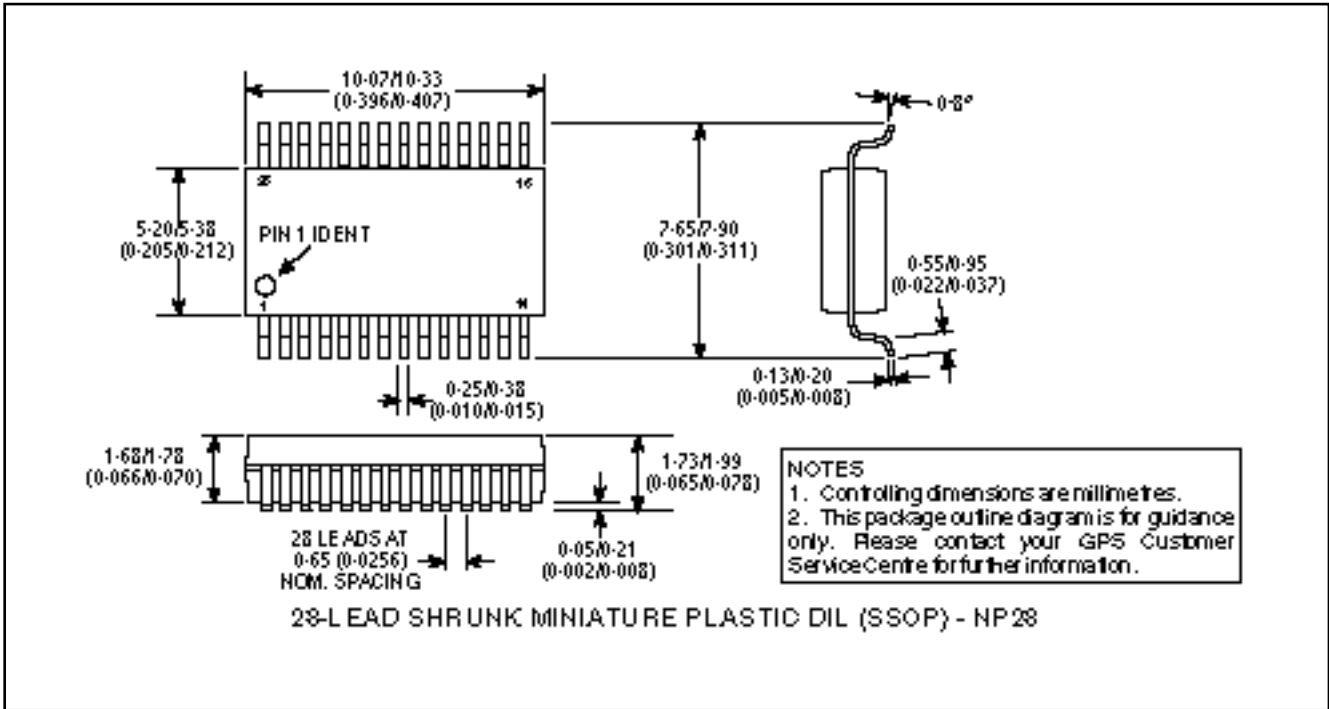

ORDERING INFORMATION

- SL6609 / KG / NPDS - SSOP devices in anti-static sticks
- SL6609 / KG / NPDE - SSOP devices in tape and reel



HEADQUARTERS OPERATIONS
GEC PLESSEY SEMICONDUCTORS
Cheney Manor, Swindon,
Wiltshire SN2 2QW, United Kingdom.
Tel: (0793) 518000
Fax: (0793) 518411

GEC PLESSEY SEMICONDUCTORS
P.O. Box 660017
1500 Green Hills Road,
Scotts Valley, California 95067-0017,
United States of America.
Tel: (408) 438 2900
Fax: (408) 438 5576

CUSTOMER SERVICE CENTRES

- **FRANCE & BENELUX** Les Ulis Cedex Tel: (1) 64 46 23 45 Fax: (1) 64 46 06 07
- **GERMANY** Munich Tel: (089) 3609 06-0 Fax: (089) 3609 06-55
- **ITALY** Milan Tel: (02) 66040867 Fax: (02) 66040993
- **JAPAN** Tokyo Tel: (03) 5276-5501 Fax: (03) 5276-5510
- **NORTH AMERICA** Scotts Valley, USA Tel (408) 438 2900 Fax: (408) 438 7023.
- **SOUTH EAST ASIA** Singapore Tel: (65) 3827708 Fax: (65) 3828872
- **SWEDEN** Stockholm, Tel: 46 8 702 97 70 Fax: 46 8 640 47 36
- **UK, EIRE, DENMARK, FINLAND & NORWAY**
Swindon Tel: (0793) 518510 Fax: (0793) 518582

These are supported by Agents and Distributors in major countries world-wide.

© GEC Plessey Semiconductors 1994 Publication No. DS3821 Issue No. 2.7 April 1994

This publication is issued to provide information only which (unless agreed by the Company in writing) may not be used, applied or reproduced for any purpose nor form part of any order or contract nor to be regarded as a representation relating to the products or services concerned. No warranty or guarantee express or implied is made regarding the capability, performance or suitability of any product or service. The Company reserves the right to alter without prior knowledge the specification, design or price of any product or service. Information concerning possible methods of use is provided as a guide only and does not constitute any guarantee that such methods of use will be satisfactory in a specific piece of equipment. It is the user's responsibility to fully determine the performance and suitability of any equipment using such information and to ensure that any publication or data used is up to date and has not been superseded. These products are not suitable for use in any medical products whose failure to perform may result in significant injury or death to the user. All products and materials are sold and services provided subject to the Company's conditions of sale, which are available on request.



**For more information about all Zarlink products
visit our Web Site at
www.zarlink.com**

Information relating to products and services furnished herein by Zarlink Semiconductor Inc. trading as Zarlink Semiconductor or its subsidiaries (collectively "Zarlink") is believed to be reliable. However, Zarlink assumes no liability for errors that may appear in this publication, or for liability otherwise arising from the application or use of any such information, product or service or for any infringement of patents or other intellectual property rights owned by third parties which may result from such application or use. Neither the supply of such information or purchase of product or service conveys any license, either express or implied, under patents or other intellectual property rights owned by Zarlink or licensed from third parties by Zarlink, whatsoever. Purchasers of products are also hereby notified that the use of product in certain ways or in combination with Zarlink, or non-Zarlink furnished goods or services may infringe patents or other intellectual property rights owned by Zarlink.

This publication is issued to provide information only and (unless agreed by Zarlink in writing) may not be used, applied or reproduced for any purpose nor form part of any order or contract nor to be regarded as a representation relating to the products or services concerned. The products, their specifications, services and other information appearing in this publication are subject to change by Zarlink without notice. No warranty or guarantee express or implied is made regarding the capability, performance or suitability of any product or service. Information concerning possible methods of use is provided as a guide only and does not constitute any guarantee that such methods of use will be satisfactory in a specific piece of equipment. It is the user's responsibility to fully determine the performance and suitability of any equipment using such information and to ensure that any publication or data used is up to date and has not been superseded. Manufacturing does not necessarily include testing of all functions or parameters. These products are not suitable for use in any medical products whose failure to perform may result in significant injury or death to the user. All products and materials are sold and services provided subject to Zarlink's conditions of sale which are available on request.

Purchase of Zarlink's I²C components conveys a licence under the Philips I²C Patent rights to use these components in an I²C System, provided that the system conforms to the I²C Standard Specification as defined by Philips.

Zarlink and the Zarlink Semiconductor logo are trademarks of Zarlink Semiconductor Inc.

Copyright 2001, Zarlink Semiconductor Inc. All Rights Reserved.

TECHNICAL DOCUMENTATION - NOT FOR RESALE
