

Metal (Oxide) Film Fusing Resistors

Type: **ERQH**
(Flame retardative hermetic type)

Type: **ERQC**
(Flameproof bath-tub type, Axial leads)

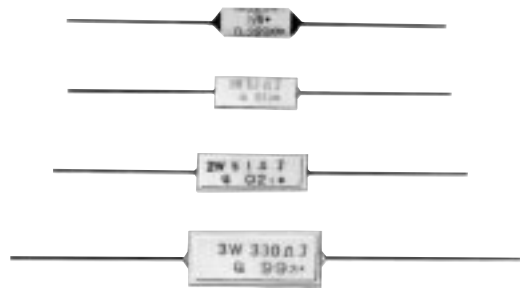

■ **Features**

- **Accurate Fusing Characteristic**
Accurate fusing characteristic can be applied to safety circuit in wide range of electronic equipment
- **Flameproof**
Safety flameproof construction in a ceramic tube or case
- **Hot Spot Temperature**
The temperature of resistor surface shall not exceed 600 °C (1112 °F)
- **Uniform Quality Reliable**
An exclusive automated process-developed, built, and used only by Matsushita and severe quality control system results in uniform quality and consistent performance in reliability
- **High Dielectric Withstanding Voltage**
Resistor may withstand a high potential up to 1000 V

■ **Construction**

Flame-retardant, hermetically sealed

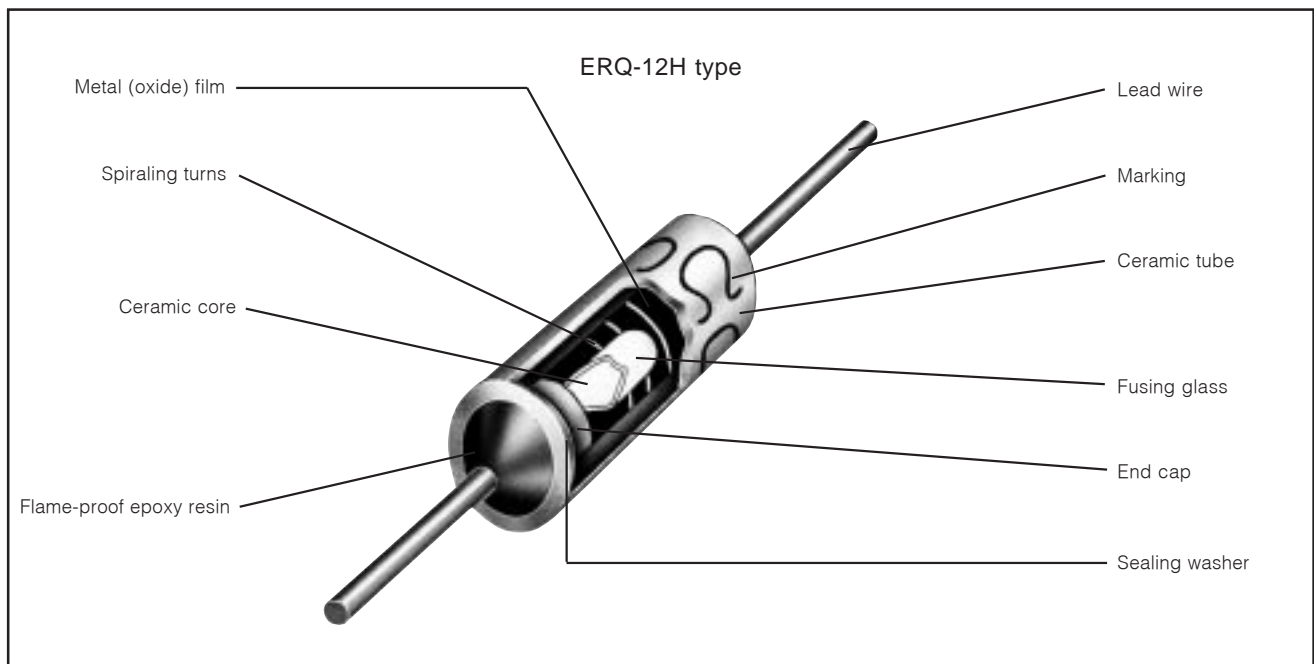

Design and specifications are each subject to change without notice. Ask factory for the current technical specifications before purchase and/or use. Should a safety concern arise regarding this product, please be sure to contact us immediately.

Explanation of Part Numbers

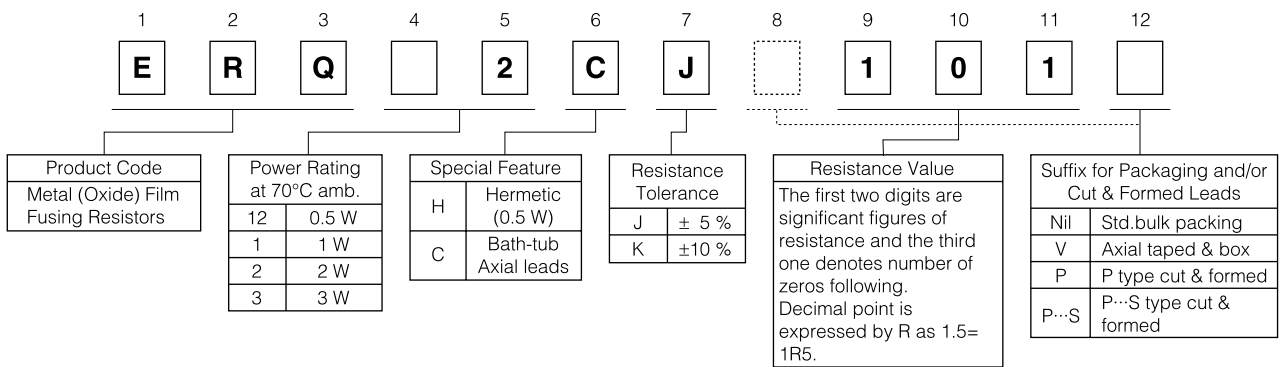

The above example shows a standard bath-tub type Metal (Oxide) Film Fusing Resistors, 2 W power rating, resistance value of 100 Ω, tolerance of 5 %, and package of standard bulk packing.

Ratings

Type	Power Rating at 70 °C (W)	Maximum Overload Voltage	Dielectric With-standing Voltage(V)	Resistance Tolerance (%)	Resistance Range (Ω)		Standard Resistance Values	Marking Method on Body	T.C.R. [$\times 10^{-6}/^{\circ}\text{C}$] (ppm/°C)]	Mass (Weight) [g/pc.]
					min.	max.				
ERQ12H	0.5	3 times of RCWV ⁽¹⁾	AC 1000	K (±10)	0.22	0.82	E12	Stamp	±500	0.73
				J (± 5)	1	3.9 k	E24			
ERQ1C	1	2.5 times of RCWV	AC 1000	K (±10)	0.33	0.82	E12			
				J (± 5)	1	1 k	E24			
ERQ2C	2		AC 1000	K (±10)	0.33	0.82	E12			
				J (± 5)	1	1 k	E24			
ERQ3C	3	AC 1000	K (±10)	0.33	0.82	E12				
			J (± 5)	1	3.3 k	E24				

(1) Rated Continuous Working Voltage (RCWV) shall be determined from $RCWV = \sqrt{\text{Power Rating} \times \text{Resistance Value}}$

Maximum Open Circuit Voltage

Referring to the maximum value of the voltage applied between terminals of the resistor when the resistor is opened in an electric circuit, it is defined by type and resistance.

Please stay within the specified voltage. (Please refer to ER115 page)

Power Derating Curve

For resistors operated in ambient temperatures above 70 °C, power rating shall be derated in accordance with the right figure.

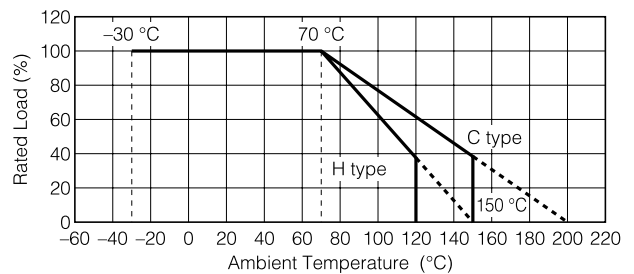

Explanation of marking

Type 12H Black stamp

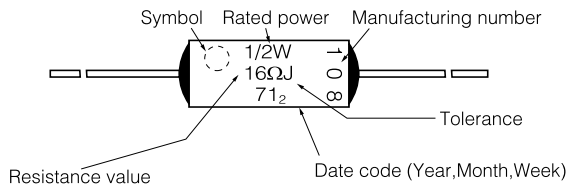

Type C Red stamp

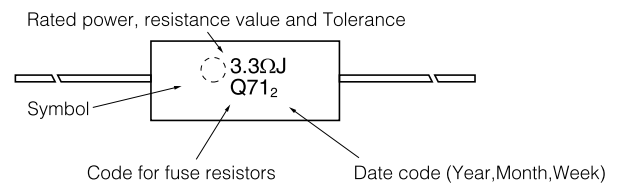

Dimensions in mm (not to scale)

Type	Dimensions (mm)				
	L	ϕD	ℓ	ϕd	A
ERQ12H	12.0 \pm 1.5	5.3 \pm 1.0	28.5 \pm 3.0	0.65 \pm 0.05	—
ERQ1C	13.0 \pm 1.0	—	25.0 \pm 4.0	0.65 \pm 0.05	5.5 \pm 1.0
ERQ2C	18.0 \pm 1.0	—	25.0 \pm 4.0	0.80 \pm 0.05	6.4 \pm 1.0
ERQ3C	22.0 \pm 1.0	—	32.0 \pm 4.0	0.80 \pm 0.05	9.5 \pm 1.0

Type ERQ12H

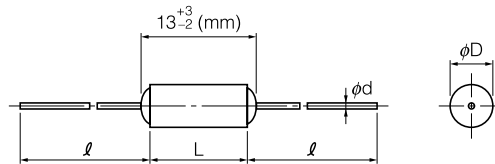

Type ERQC

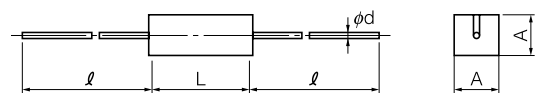

Cut & Formed Type

Type "P"

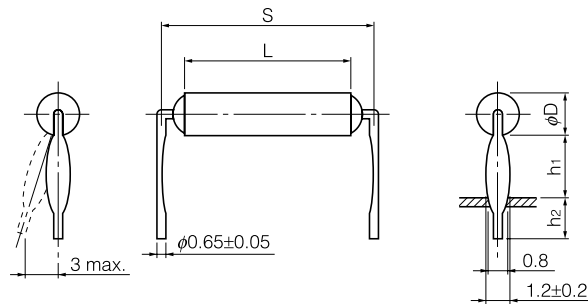

Unit: mm

Part No.	L	ϕD	S	h_1	h_2
ERQ12H□□□□P	12.0 \pm 1.5	$\phi 5.3 \pm 1.0$	17.5 \pm 1.5	5.85 \pm 1.50	4.0 \pm 1.0

Type "P...S"

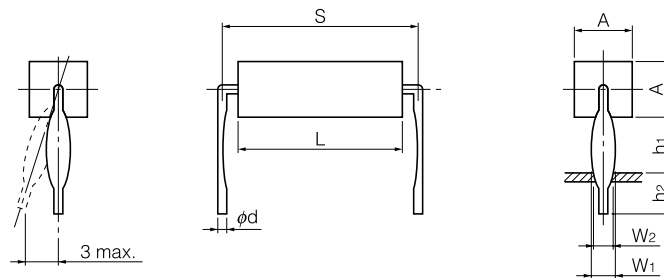

Unit: mm

Part No.	L	S	ϕd	A	h_1	h_2	W_1	W_2
ERQ1C□P□□□S (1 W)	13.0 \pm 1.0	20.0 \pm 2.0	0.65 \pm 0.10	5.5 \pm 1.0	6.0 \pm 1.5	4.0 \pm 1.0	1.2 \pm 0.2	0.8
ERQ2C□P□□□S (2 W)	18.0 \pm 1.0	25.0 \pm 2.0	0.80 \pm 0.10	6.4 \pm 1.0	5.8 \pm 1.5	4.0 \pm 1.0	1.4 \pm 0.2	1

Design and specifications are each subject to change without notice. Ask factory for the current technical specifications before purchase and/or use. Should a safety concern arise regarding this product, please be sure to contact us immediately.

■ Axial Taping Specifications
Type ERQ12H

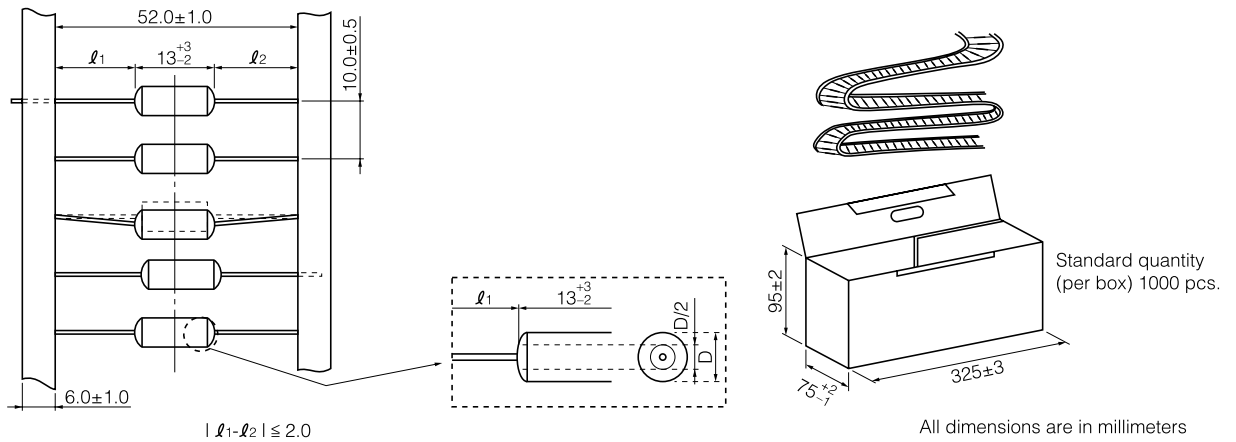

■ Packaging Methods
Contact factory packaging methods. (Type ERQC)

■ Performance Specifications

Characteristics	Specifications	Test Methods
Flame-Retardancy	Not have any specimens which burn with flaming combustion time for more than 10 seconds after each application of the test flame.	The test flame is placed to remain for 15 seconds and removed for 15 seconds. The test shall be repeated until resistor has been subjected to 5 applications of the test flame.
Fusing Characteristics	When resistors are tested using the specified circuit, the resistors shall meet the requirements specified respectively. (Refer to ER114 page)	Tested on individual specified circuit, using stable power supply.
Maximum open circuit voltage	When resistors are tested using the specified circuit, the resistors shall meet the requirements specified respectively. (Refer to ER115 page)	Tested on individual specified circuit.

Design and specifications are each subject to change without notice. Ask factory for the current technical specifications before purchase and/or use. Should a safety concern arise regarding this product, please be sure to contact us immediately.

■ Fusing characteristics for ERQH, C type

(unit : sec)

ERQ12H type		Multiple of the power rating (times)						
		10	12	16	20	25	30	40
Resistance value	0.22 to 0.82 (Ω)	/	/	/	/	≤ 30	≤ 25	≤ 10
	1.0 to 4.3 (Ω)	/	/	/	≤ 45	≤ 25	≤ 20	≤ 10
	4.7 to 16 (Ω)	/	≤ 180	≤ 90	≤ 45	≤ 25	≤ 20	≤ 10
	18 to 47 (Ω)	≤ 150	≤ 120	≤ 60	≤ 45	≤ 15	≤ 10	≤ 7
	51 to 200 (Ω)	/	/	/	/	≤ 45	≤ 25	≤ 10
	220 to 620 (Ω)	/	/	/	≤ 45	≤ 30	≤ 20	≤ 10
	680 to 3.9 k (Ω)	/	≤ 180	≤ 90	≤ 45	≤ 25	/	/

(unit : sec)

ERQ1C type		Multiple of the power rating (times)					
		10	12	16	20	25	30
Resistance value	0.33 to 0.91 (Ω)	/	≤ 300	≤ 180	≤ 40	≤ 20	≤ 10
	1.0 to 3.9 (Ω)	/	≤ 90	≤ 45	≤ 15	≤ 7	≤ 7
	4.3 to 16 (Ω)	≤ 90	≤ 60	≤ 30	≤ 10	≤ 7	≤ 7
	18 to 47 (Ω)	≤ 60	≤ 30	≤ 15	≤ 10	≤ 7	≤ 7
	51 to 180 (Ω)	/	/	≤ 90	≤ 20	≤ 15	≤ 10
	200 to 620 (Ω)	/	/	≤ 60	≤ 20	≤ 7	≤ 7
	680 to 1 k (Ω)	/	≤ 90	≤ 60	≤ 10	≤ 7	≤ 7

(unit : sec)

ERQ2C type		Multiple of the power rating (times)					
		10	12	16	20	25	30
Resistance value	0.33 to 0.91 (Ω)	/	/	≤ 90	≤ 30	≤ 15	≤ 7
	1.0 to 3.9 (Ω)	/	≤ 90	≤ 45	≤ 20	≤ 15	≤ 7
	4.3 to 30 (Ω)	/	≤ 45	≤ 30	≤ 10	≤ 7	≤ 7
	33 to 47 (Ω)	≤ 45	≤ 30	≤ 20	≤ 10	≤ 7	≤ 7
	51 to 180 (Ω)	/	≤ 120	≤ 60	≤ 20	≤ 10	≤ 7
	200 to 620 (Ω)	/	≤ 90	≤ 30	≤ 10	≤ 7	≤ 7
	680 to 1 k (Ω)	≤ 60	≤ 30	≤ 20	≤ 10	≤ 7	≤ 7

(unit : sec)

ERQ3C type		Multiple of the power rating (times)					
		10	12	16	20	25	30
Resistance value	0.33 to 0.91 (Ω)	/	/	≤ 240	≤ 90	≤ 45	≤ 20
	1.0 to 3.9 (Ω)	/	/	≤ 240	≤ 90	≤ 20	≤ 15
	4.3 to 20 (Ω)	≤ 300	≤ 120	≤ 60	≤ 20	≤ 15	≤ 15
	22 to 91 (Ω)	≤ 100	≤ 60	≤ 30	≤ 15	≤ 15	≤ 15
	100 to 200 (Ω)	/	≤ 180	≤ 90	≤ 30	≤ 20	≤ 15
	220 to 3.3 k (Ω)	/	≤ 90	≤ 60	≤ 20	≤ 15	≤ 15

Design and specifications are each subject to change without notice. Ask factory for the current technical specifications before purchase and/or use. Should a safety concern arise regarding this product, please be sure to contact us immediately.

Maximum open circuit voltage for ERQH, C type

Maximum open circuit voltage

Referring to the maximum value of the voltage applied between terminals of the resistor when the resistor is opened in an electric circuit, it is defined by type and resistance. Please stay within the specified voltage. Shall be confirmed carefully in actual circuit before use.



Testing circuit

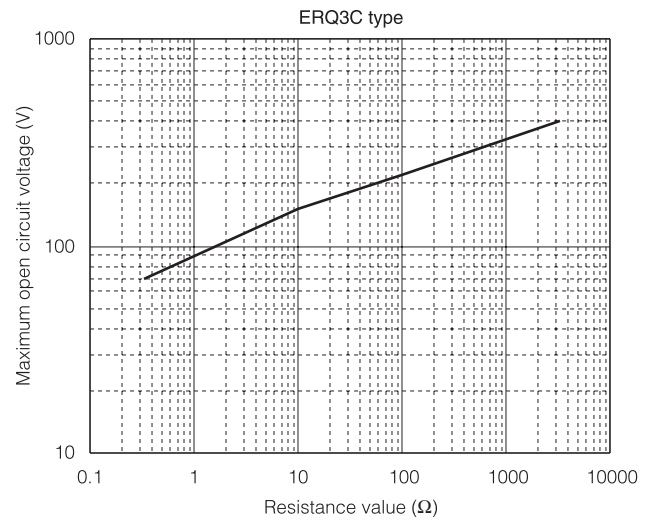
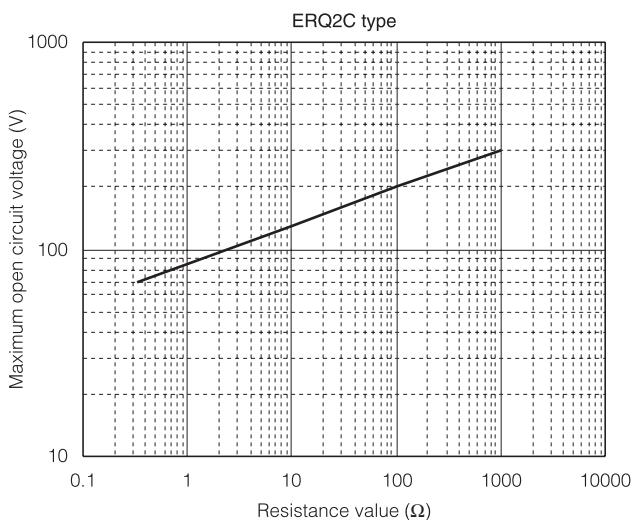
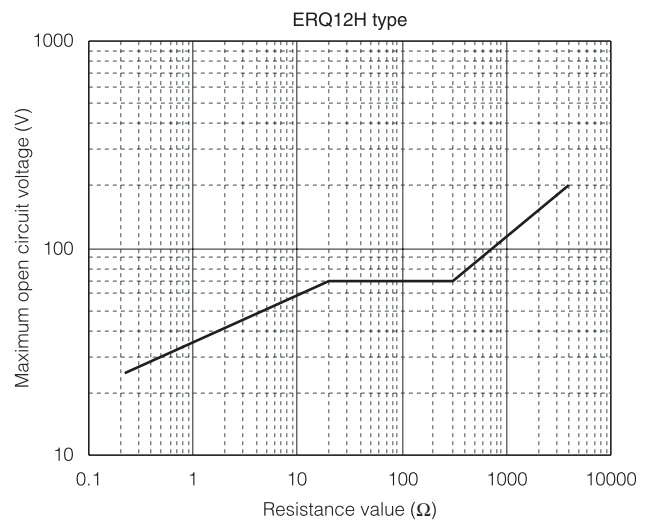
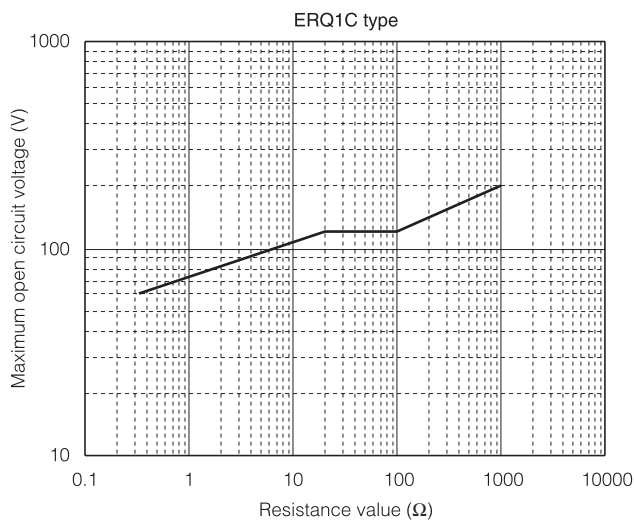

Design and specifications are each subject to change without notice. Ask factory for the current technical specifications before purchase and/or use. Should a safety concern arise regarding this product, please be sure to contact us immediately.

⚠ Cautions for Safety

The following are precautions for individual products. Please also refer to the precautions common to Fixed Resistors shown on page ER3 of this catalog.

1. Checking the fusing conditions
 - 1) Fusing characteristics differ depending on the type, shape, and resistance. Check the fusing conditions before selecting the type of Metal (Oxide) Film Fusing Resistors (hereafter called the Fusing Resistors) to be used.
 - 2) Use the Fusing Resistors under the maximum open circuit voltage. Otherwise, arcing may occur when a voltage much higher than the rated one is applied in the event of an abnormality in the circuit, or when a high voltage is applied after fusing.
2. Checking for pulse voltage, impact voltage, and transient voltage

Make sure to evaluate and check the Fusing Resistors mounted on your product if they are to be mounted on a circuit that generates an impact voltage, or if there is a possibility that the transient phenomenon (significantly high voltage applied in a short time) may occur or that a pulse voltage with a high peak voltage may be applied. Make sure to consult our sales staff before using the Fusing Resistors under special conditions.
3. Conditions of use in a steady state

Make sure that the load conditions have a sufficient allowance for the power derating curve. The characteristics of the Fusing Resistors are set by using a constant voltage circuit.

(Data for Reference)

■ Pulse Characteristics (Usual)

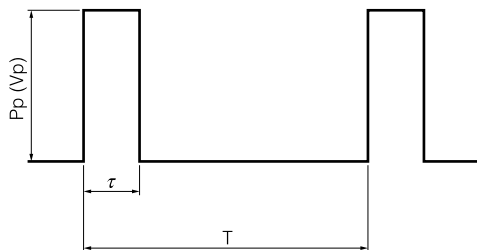

- P_p : Pulse limit power (W)
- V_p : Pulse limit voltage (V)
- τ : Pulse continuous time (s)
- T : Period (s)
- V_R : Rated voltage (V)
- P : Rated power (W)
- R : Resistance value (Ω)
- $V_{p\ max.}$: Max. pulse limit voltage (V)

Withstand pulse limit power is calculated by the next method.

$$P_p = K \cdot P \cdot T/\tau$$

$$V_p = \sqrt{K \cdot P \cdot R \cdot T/\tau}$$

Reference to the right about a fixed number of $V_{p\ max.}$

Type	K	$V_{p\ max.}$ (V)
ERQ12H	0.60	200
ERQ1C	0.30	200
ERQ2C	0.25	300
ERQ3C	0.20	300

- $T > 1(s) \rightarrow T = 1(s)$
- $T/\tau > 100 \rightarrow T/\tau = 100$
- $P_p < P \rightarrow P$ stands for P_p
($V_p < V_R \rightarrow V_R$ stands for V_p)
- Added voltage $\leq V_{p\ max.}$
- P_p or V_p is reference value
Conditions : Pulse added time=1000 h
Resistance change= $\pm 5\%$
Room temperature

Design and specifications are each subject to change without notice. Ask factory for the current technical specifications before purchase and/or use. Should a safety concern arise regarding this product, please be sure to contact us immediately.

■ Fusing Characteristics (Constant Voltage Circuit)

(Fusing specification is refer to ER114 page)

ERQ12H

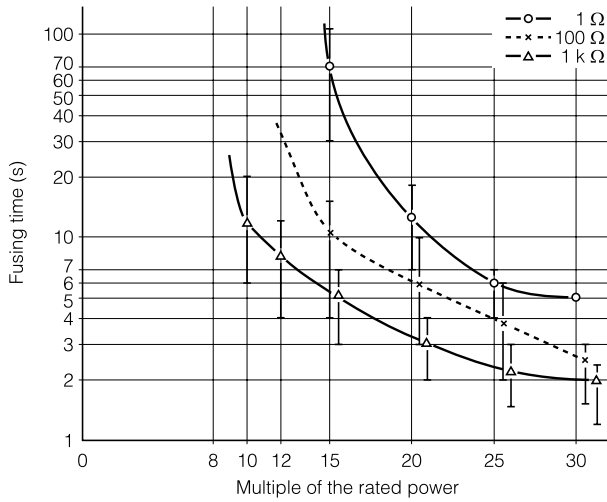

ERQ1C

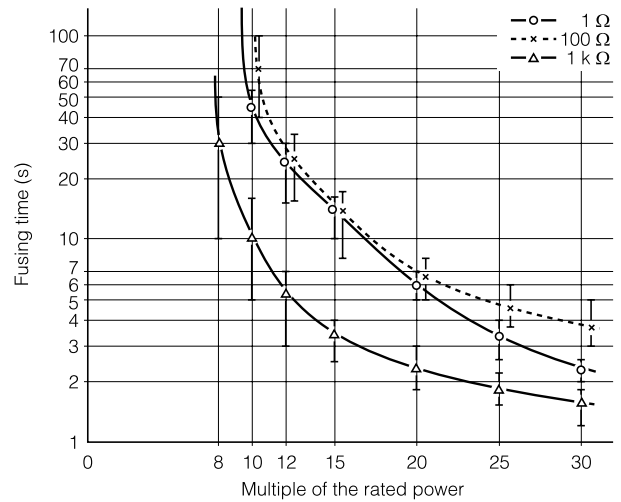

ERQ2C

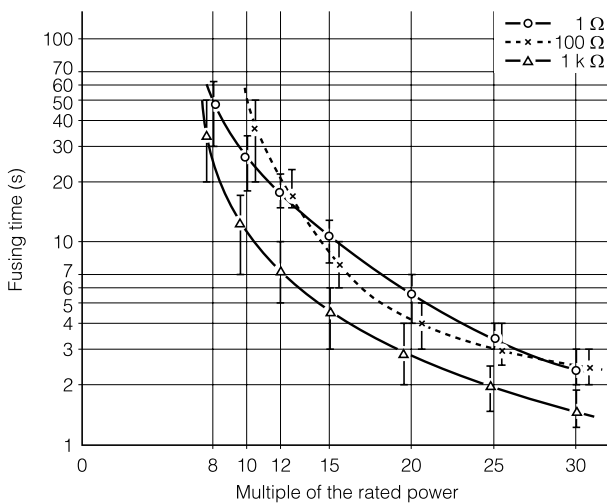

ERQ3C

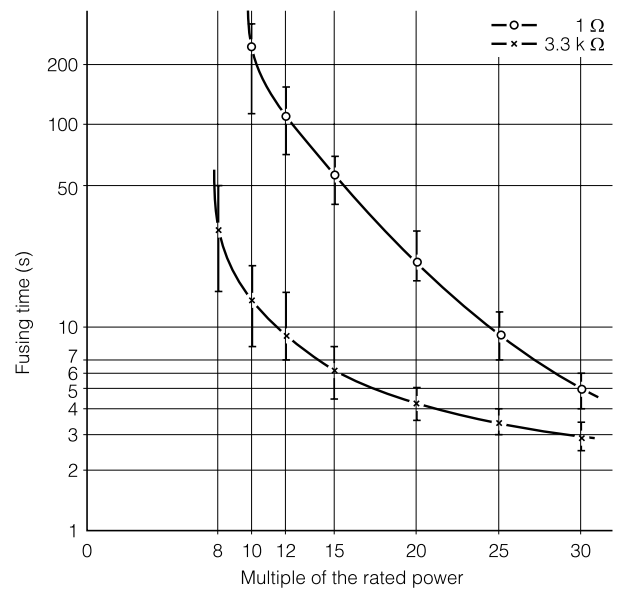

■ Hot Spot Temperature (for Reference)

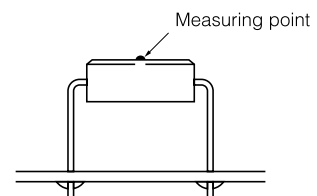
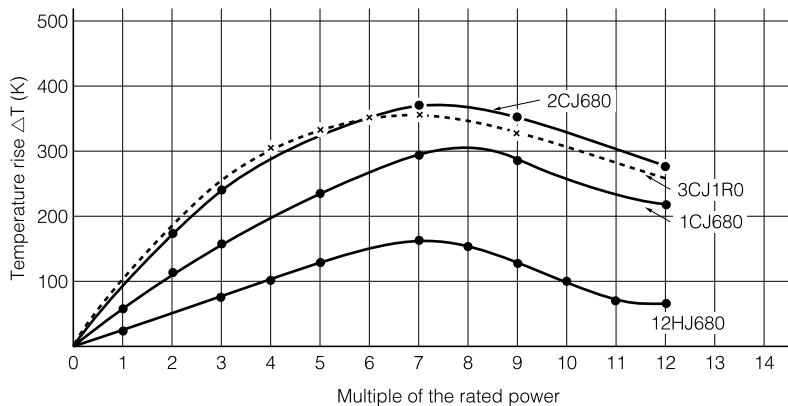

Design and specifications are each subject to change without notice. Ask factory for the current technical specifications before purchase and/or use. Should a safety concern arise regarding this product, please be sure to contact us immediately.

⚠ Caution for Safety

(Common precautions for Fixed Resistors)

- When using our products, no matter what sort of equipment they might be used for, be sure to make a written agreement on the specifications with us in advance. The design and specifications in this catalog are subject to change without prior notice.
- Do not use the products beyond the specifications described in this catalog.
- This catalog explains the quality and performance of the products as individual components. Before use, check and evaluate their operations when installed in your products.
- Install the following systems for a failsafe design to ensure safety if these products are to be used in equipment where a defect in these products may cause the loss of human life or other significant damage, such as damage to vehicles (automobile, train, vessel), traffic lights, medical equipment, aerospace equipment, electric heating appliances, combustion/gas equipment, rotating equipment, and disaster/crime prevention equipment.
 - * Systems equipped with a protection circuit and a protection device
 - * Systems equipped with a redundant circuit or other system to prevent an unsafe status in the event of a single fault

(1) Precautions for use

- These products are designed and manufactured for general purpose and standard use in general electronic equipment (e.g. AV equipment, home electric appliances, office equipment, information and communication equipment)
- These products are not intended for use in the following special conditions. Before using the products, carefully check the effects on their quality and performance, and determine whether or not they can be used.
 1. In liquid, such as water, oil, chemicals, or organic solvent
 2. In direct sunlight, outdoors, or in dust
 3. In salty air or air with a high concentration of corrosive gas, such as Cl₂, H₂S, NH₃, SO₂, or NO₂
 4. In an environment where strong static electricity or electromagnetic waves exist
 5. In an environment where these products cause dew condensation
 6. Sealing or coating of these products or a printed circuit board on which these products are mounted, with resin or other materials
- These products generate Joule heat when energized. Carefully position these products so that their heat will not affect the other components.
- Carefully position these products so that their temperatures will not exceed the category temperature range due to the effects of neighboring heat-generating components. Do not mount or place heat-generating components or inflammables, such as vinyl-coated wires, near these products .
- Note that non-cleaning solder, halogen-based highly active flux, or water-soluble flux may deteriorate the performance or reliability of the products.
- Carefully select a flux cleaning agent for use after soldering. An unsuitable agent may deteriorate the performance or reliability. In particular, when using water or a water-soluble cleaning agent, be careful not to leave water residues. Otherwise, the insulation performance may be deteriorated.

(2) Precautions for storage

The performance of these products, including the solderability, is guaranteed for a year from the date of arrival at your company, provided that they remain packed as they were when delivered and stored at a temperature of 5 °C to 35 °C and a relative humidity of 45 % to 85 %.

Even within the above guarantee periods, do not store these products in the following conditions. Otherwise, their electrical performance and/or solderability may be deteriorated, and the packaging materials (e.g. taping materials) may be deformed or deteriorated, resulting in mounting failures.

1. In salty air or in air with a high concentration of corrosive gas, such as Cl₂, H₂S, NH₃, SO₂, or NO₂
2. In direct sunlight

<Package markings>

Package markings include the product number, quantity, and country of origin. In principle, the country of origin should be indicated in English.