

The SL6619 is an advanced Direct Conversion FSK Data Receiver for operation up to 450 MHz. The device integrates all functions to convert a binary FSK modulated RF signal into a demodulated data stream.

Adjacent channel rejection is provided using tuneable gyrator filters. RF and audio AGC functions assist operation when large interfering signals are present and an automatic frequency control (AFC) function is provided to extend centre frequency acceptance.

Features

- Very Low Power Operation from Single Cell
- Superior Sensitivity
- Operation at 512, 1200 and 2400 Baud
- On Chip 1 Volt Regulator
- 1mm Height Miniature Package
- Automatic Frequency Control Function
- Programmable Post Detection Filter
- AGC Detection Circuitry
- Power Down Function
- Battery Strength Indicator

Applications

- Pagers, including Credit Card, PCMCIA and Watch Pagers
- Low Data Rate Receivers, e.g. Security Systems

Ordering Information		
SL6619/KG/TP1N	32 Pin TQFP	Trays
SL6619/KG/TP1Q	32 Pin TQFP	Tape & Reel
SL6619/KG/TP2Q	32 Pin TQFP*	Tape & Reel
SL6619/KG/TP2N	32 Pin TQFP*	Trays

*Pb Free Matte Tin

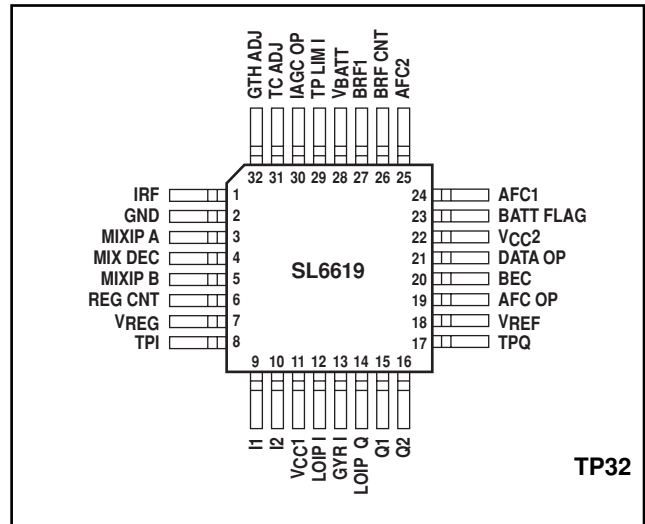

Figure 1 Pin identification diagram (top view). See Table 1 for pin descriptions

ABSOLUTE MAXIMUM RATINGS

Storage temperature	-55°C to +150°C
Operating temperature	-10°C to +55°C
Maximum voltage on any pin w.r.t. any other pin, subject to the following conditions:	+4V
Current, pin 3 (MIXIP), pin 5 (MIXPB), pin 12 (LOIP I) and pin 14 (LOIPB)	<5ma
Most negative voltage on any pin	-0.5V w.r.t. gnd

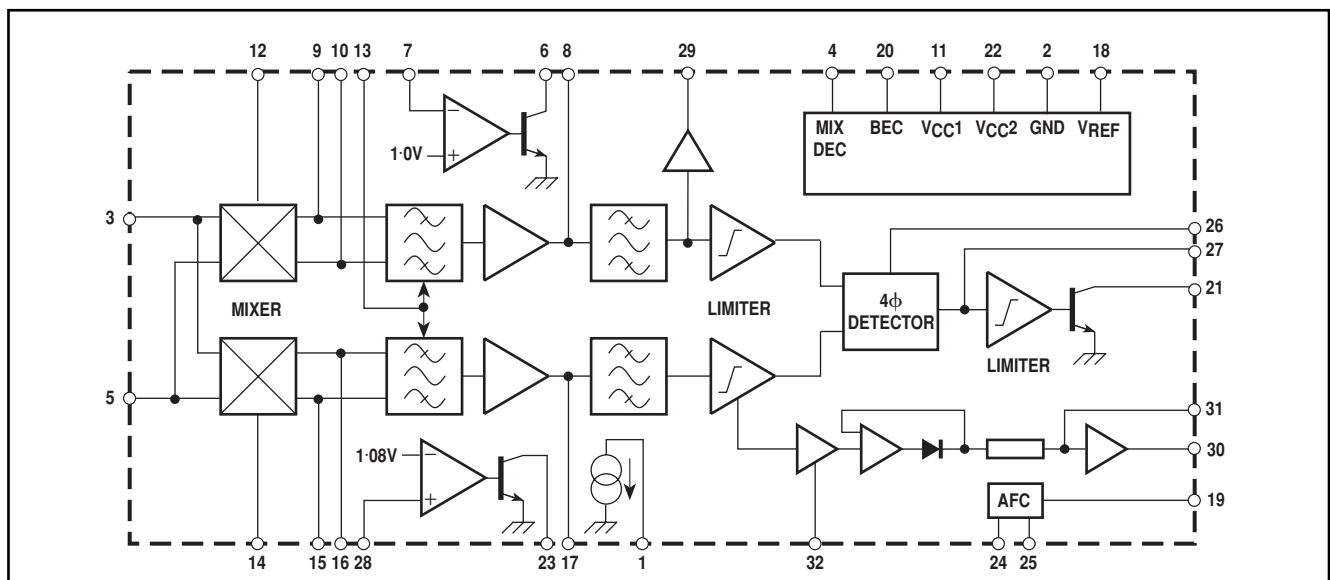

Figure 2 - Block diagram of SL6619

Zarlink Semiconductor Inc.

Zarlink, ZL and the Zarlink Semiconductor logo are trademarks of Zarlink Semiconductor Inc.

Copyright 1998 - 2005, Zarlink Semiconductor Inc. All Rights Reserved.

Pin number	Pin name	Pin description
1	IRF	LNA current source
2	GND	Ground
3	MIXIP A	Mixer input A
4	MIX DEC	Mixer biasing decouple
5	MIXIP B	Mixer input B
6	REG CNT	1V regulator control external PNP drive
7	VREG	1V regulator output voltage
8	TPI	I channel pre-yrator filter test point.
9	I1	Mixer output, I channel
10	I2	Mixer output, I channel
11	VCC1	Positive supply 1
12	LOIP I	LO input channel I
13	GYRI	Gyrator current adjust pin
14	LOIP Q	LO input channel Q
15	Q1	Mixer output, Q channel
16	Q2	Mixer output, Q channel
17	TPQ	Q channel pre-yrator filter test point
18	VREF	Reference voltage
19	AFC OP	AFC output
20	BEC	Battery economy control
21	DATA OP	Data output pin
22	VCC2	Positive supply 2
23	BATT FLAG	Battery flag output
24	AFC1	AFC characteristic defining pin
25	AFC2	AFC characteristic defining pin
26	BRF CNT	Bit rate filter control
27	BRF1	Bit rate filter 1, output from detector
28	VBATT	Battery flag input voltage
29	TP LIM I	I channel limiter (post gyrator filter) test point, output only
30	IAGC OP	Audio AGC output current
31	TC ADJ	Audio AGC time constant adjust
32	GTH ADJ	Audio AGC gain and threshold adjust. RSSI signal indicator

Table 1 - SL6619 pin descriptions

Electrical Characteristics (1)

Electrical Characteristics (1) are guaranteed over the following range of operating conditions unless otherwise stated

$$T_{AMB} = +25^{\circ}\text{C}, V_{CC1} = 1.3\text{V}, V_{CC2} = 2.7\text{V}$$

Characteristic	Pin	Value			Units	Conditions
		Min.	Typ.	Max.		
Supply voltage, V_{CC1}	11	0.95	1.3	2.7	V	$V_{CC1} \leq V_{CC2} - 0.8\text{V}$ Including IRF $I_{LOAD} = 3\text{mA}$, external PNP ($\beta \geq 100$, $V_{CE} = 0.1\text{V}$) External PNP ($h_{FE} \geq 100$, $V_{CE} = 0.1\text{V}$) PTAT, voltage on pin 1 = 0.3V and 1.3V Typical temperature coefficient = +0.1mV/°C
Supply voltage, V_{CC2}	22	1.9	2.7	3.5	V	
Supply current, I_{CC1}	11	1.20	1.60	2.2	mA	
Supply current, I_{CC2}	22	260	350	460	μA	
1 volt regulator, V_{REG}	7	0.95	1.0	1.05	V	
1 volt regulator load current	7	0.25		3	mA	
LNA current source, IRF	1	375	500	700	μA	
Reference voltage, V_{REF}	18	1.15	1.25	1.31	V	
V_{REF} source current	18			20	μA	
V_{REF} sink current	18			1.0	μA	
Data Amplifier						
DATA OP sink current	21	25			μA	Output logic low, pin 21 voltage = 0.3V Output logic high, pin 21 voltage = V_{CC2} Preamble at 1200 baud, $\Delta f = 4\text{kHz}$, pin 26 = 0V, BRF capacitor = 560pF, DATA OP pullup resistor = 200k Ω
DATA OP leakage current	21			1.0	μA	
Output mark:space ratio	21	7:9		9:7		
Battery Economy						
Power down I_{CC1}	11		0.5	10	μA	Pin 20 = logic low Pin 20 = logic low Powered up Powered down Powered up Powered down
Power down I_{CC2}	22		2.0	10	μA	
BEC input logic high	20	$V_{CC2} - 0.3\text{V}$		V_{CC2}	V	
BEC input logic low	20	0		0.3	V	
BEC input current	20	-1.0		1.0	μA	
BEC input current	20	-1.0		1.0	μA	
Battery Flag						
V_{BATT} trigger point	28	1.04	1.08	1.12	V	Current sunk by pin 23 = 1 μA Pin 28 voltage = 1.04V Pin 28 voltage = 1.12V Pin 28 voltage = 1.14V
BATT FLAG sink current	23			1.0	μA	
BATT FLAG sink current	23	1.0			μA	
BATT FLAG sink current	23	25			μA	
V_{BATT} input voltage	28			2.0	V	
V_{BATT} input current	28	-1.0		1.0	μA	$V_{BATT} = 1.14\text{V}$
V_{BATT} input current	28	-1.0		1.0	μA	$V_{BATT} = 1.04\text{V}$

SL6619 Data Sheet

Electrical Characteristics (1) (Cont.)

Electrical Characteristics (1) are guaranteed over the following range of operating conditions unless otherwise stated

$$T_{AMB} = +25^{\circ}\text{C}, V_{CC1} = 1.3\text{V}, V_{CC2} = 2.7\text{V}$$

Characteristic	Pin	Value			Units	Conditions
		Min.	Typ.	Max.		
Mixers						
LO DC bias voltage	12,14		V_{CC1}		V	
Gain to TPI	3,5,8,12	38	42	46	dB	LO inputs (12, 14) driven in quadrature: 45mVrms at 450MHz, CW. Mixer inputs (3, 5) driven differentially: 0.45mVrms at 450.004MHz, CW.
Gain to TPQ	3,5,14,17	38	42	46	dB	As gain to TPI
Match of gain to TPI and TPQ	3,5,8,12,14,17	-1	0	+1	dB	As gain to TPI
Audio AGC						
IAGC OP max. sink current	30		40		μA	TPI, TPQ signals limiting
IAGC OP leakage current	30			1	μA	No signal applied
AFC						
AFC DC current, I_{AFC4k5}	19		0.0		μA	$f_C = f_{LO} + 4.5\text{kHz}$, CW
AFC DC current	19	$I_{AFC4k5} + 0.2$	$I_{AFC4k5} + 0.7$		μA	$f_C = f_{LO} + 2.5\text{kHz}$, CW
AFC DC current	19		$I_{AFC4k5} - 0.9$	$I_{AFC4k5} - 0.2$	μA	$f_C = f_{LO} + 6.5\text{kHz}$, CW
Bit Rate Filter Control						
BRF CNT input logic high	26	$V_{CC2} - 0.3$		V_{CC2}	V	2400 baud
BRF CNT input logic low	26	0		0.1	V	1200 baud
Tristate I/P current window	26	-0.4		+0.4	μA	512 baud
BRF 1 output current	27		3.5		μA	Pin 26 logic high
BRF 1 output current	27		1.7		μA	Pin 26 logic low
BRF 1 output current	27		0.74		μA	Pin 26 logic tristate (open circuit)
BRF CNT input high current	26	-7.5		+7.5	μA	
BRF CNT input low current	26	-7.5		+7.5	μA	

Electrical Characteristics (2)

Electrical Characteristics (2) are guaranteed over the following range of operating conditions unless otherwise stated. Characteristics are tested at room temperature only and are guaranteed by characterisation test or design.

$$T_{AMB} = -10^{\circ}\text{C to } +55^{\circ}\text{C}, V_{CC1} = 1.4\text{V to } 2.0\text{V}, V_{CC2} = 2.3\text{V to } 3.2\text{V}, V_{CC1} < V_{CC2} - 0.8\text{V}$$

Characteristic	Pin	Value			Units	Conditions
		Min.	Typ.	Max.		
Supply voltage, V_{CC1}	11	0.95	1.3	2.7	V	$V_{CC1} \leq V_{CC2} - 0.8\text{V}$ at $\geq 25^{\circ}\text{C}$ only Including IRF $I_{LOAD} = 3\text{mA}$, external PNP ($\beta \geq 100$, $V_{CE} = 0.1\text{V}$) External PNP ($h_{FE} \geq 100$, $V_{CE} = 0.1\text{V}$) PTAT, voltage on pin 1 = 0.3V and 1.3V Typical temperature coefficient = $+0.1\text{mV}/^{\circ}\text{C}$ Stable data O/P when 3dB above sensitivity. $C_{VREF} = 2.2\mu\text{F}$ Fall to 10% of steady state I_{CC1} . $C_{VREF} = 2.2\mu\text{F}$
Supply voltage, V_{CC2}	22	1.9	2.7	3.5	V	
Supply current, I_{CC1}	11		1.60	2.4	mA	
Supply current, I_{CC2}	22		350	510	μA	
1 volt regulator, V_{REG}	7	0.93	1.0	1.05	V	
1 volt regulator load current	7	0.25		3	mA	
LNA current source, IRF	1	375	500	800	μA	
Reference voltage, V_{REF}	18	1.13	1.25	1.33	V	
V_{REF} source current	18			18	μA	
V_{REF} sink current	18			0.8	μA	
Turn-on time			5		ms	
Turn-off time			1		ms	
Data Amplifier						
DATA OP sink current	21	22			μA	Output logic low, pin 21 voltage = 0.3V Output logic high, pin 21 voltage = V_{CC2} Preamble at 1200 baud, $\Delta f = 4\text{kHz}$, pin 26 = 0V, BRF capacitor = 560pF, DATA OP pullup resistor = 200k Ω
DATA OP leakage current	21			1.5	μA	
Output mark:space ratio	21	7:9		9:7		
Battery Economy						
Power down I_{CC1}	11		0.5	12	μA	Pin 20 = logic low Pin 20 = logic low Powered up Powered down Powered up Powered down
Power down I_{CC2}	22		2.0	12	μA	
BEC input logic high	20	$V_{CC2} - 0.3\text{V}$		V_{CC2}	V	
BEC input logic low	20	0		0.3	V	
BEC input current	20	-1.0		1.5	μA	
BEC input current	20	-1.0		1.5	μA	
Battery Flag						
V_{BATT} trigger point	28	1.04	1.08	1.12	V	Current sunk by pin 23 = 1 μA Pin 28 voltage = 1.04V Pin 28 voltage = 1.12V Pin 28 voltage = 1.14V $V_{BATT} = 1.14\text{V}$ $V_{BATT} = 1.04\text{V}$
BATT FLAG sink current	23			2	μA	
BATT FLAG sink current	23	2			μA	
BATT FLAG sink current	23	20			μA	
V_{BATT} input voltage	28			2.0	V	
V_{BATT} input current	28	-1.5		1.5	μA	
V_{BATT} input current	28	-1.5		1.5	μA	

Electrical Characteristics (2) (Cont.)

Electrical Characteristics (2) are guaranteed over the following range of operating conditions unless otherwise stated. Characteristics are tested at room temperature only and are guaranteed by characterisation test or design.

$$T_{AMB} = -10^{\circ}\text{C to } +55^{\circ}\text{C}, V_{CC1} = 1.4\text{V to } 2.0\text{V}, V_{CC2} = 2.3\text{V to } 3.2\text{V}, V_{CC1} < V_{CC2} - 0.8\text{V}$$

Characteristic	Pin	Value			Units	Conditions
		Min.	Typ.	Max.		
Mixers						
LO DC bias voltage	12,14		V_{CC1}		V	
Gain to TPI	3,5,8,12	35	42	46	dB	LO inputs (12, 14) driven in quadrature: 45mVrms at 450MHz, CW. Mixer inputs (3, 5) driven differentially: 0.45mVrms at 450.004MHz, CW.
Gain to TPQ	3,5,14,17	35	42	46	dB	As gain to TPI
Match of gain to TPI and TPQ	3,5,8,12,14,17	-1.5	0	+1.5	dB	As gain to TPI
Audio AGC						
IAGC OP max. sink current	30	15	40	80	μA	TPI, TPQ signals limiting
IAGC OP leakage current	30			2	μA	No signal applied
AFC						
AFC DC current, I_{AFC4k5}	19		0.0		μA	$f_C = f_{LO} + 4.5\text{kHz}$, CW
AFC DC current	19	$I_{AFC4k5} + 0.1$	$I_{AFC4k5} + 0.7$		μA	$f_C = f_{LO} + 2.5\text{kHz}$, CW
AFC DC current	19		$I_{AFC4k5} - 0.9$	$I_{AFC4k5} - 0.1$	μA	$f_C = f_{LO} + 6.5\text{kHz}$, CW
Bit Rate Filter Control						
BRF CNT input logic high	26	$V_{CC2} - 0.3$		V_{CC2}	V	2400 baud
BRF CNT input logic low	26	0		0.1	V	1200 baud
Tristate I/P current window	26	-0.4		+0.4	μA	512 baud
BRF 1 output current	27		3.5		μA	Pin 26 logic high
BRF 1 output current	27		1.7		μA	Pin 26 logic low
BRF 1 output current	27		0.74		μA	Pin 26 logic tristate (open circuit)
BRF CNT input high current	26	-10		+10	μA	
BRF CNT input low current	26	-10		+10	μA	

Receiver Characteristics (450MHz)

Receiver Characteristics (450MHz) are guaranteed over the following range of operating conditions unless otherwise stated. Characteristics are not tested but are guaranteed by characterisation test or design. All measurements made using the characterisation circuit Fig. 5. See Application Note AN137 for details of test method.

$T_{AMB} = -10^{\circ}\text{C}$ to $+55^{\circ}\text{C}$, $V_{CC1} = 1.04\text{V}$ to 2.0V , $V_{CC2} = 2.3\text{V}$ to 3.2V , $V_{CC1} < V_{CC2} - 0.8\text{V}$, carrier frequency = 450MHz , BER = 1 in 30, AFC open loop. LNA gain set such that an RF signal of -73dBm at the LNA input, offset from the LO by 4kHz , gives a typical IF signal level of 300mV p-p at TPI and TPQ. LNA noise figure $< 2\text{dB}$

Characteristic	Value			Units	Conditions	
	Min.	Typ.	Max.			
Sensitivity		-128		dBm	512bps, $\Delta f = 4.5\text{kHz}$	
		-126	-122	dBm	1200bps, $\Delta f = 4.0\text{kHz}$	
		-123	-119	dBm	2400bps, $\Delta f = 4.5\text{kHz}$. LO = -15dBm	
Intermodulation, IM3		57		dB	512bps, $\Delta f = 4.5\text{kHz}$	
	50	55		dB	1200bps, $\Delta f = 4.0\text{kHz}$	
	48	53		dB	2400bps, $\Delta f = 4.5\text{kHz}$. LO = -15dBm . Channel spacing 25kHz	
Adjacent Channel		74		dB	512bps, $\Delta f = 4.5\text{kHz}$	
	62.5	72		dB	1200bps, $\Delta f = 4.0\text{kHz}$	
	60	69		dB	2400bps, $\Delta f = 4.5\text{kHz}$. LO = -15dBm . Channel spacing 25kHz	
Deviation Acceptance	Up	+1.9		kHz	512bps, $\Delta f = 4.5\text{kHz}$, no AFC	
	Down	-2.5		kHz	512bps, $\Delta f = 4.5\text{kHz}$, no AFC	
	Up	+1.8	+3.0	+4.6	kHz	1200bps, $\Delta f = 4.0\text{kHz}$, no AFC
	Down	-2.7	-2.3	-1.7	kHz	1200bps, $\Delta f = 4.0\text{kHz}$, no AFC
	Up	+1.7	+2.5	+4.6	kHz	2400bps, $\Delta f = 4.5\text{kHz}$, no AFC
	Down	-3	-2.3	-1.7	kHz	2400bps, $\Delta f = 4.5\text{kHz}$, no AFC
Centre Frequency Acceptance		± 2.8		kHz	512bps, $\Delta f = 4.5\text{kHz}$, no AFC	
	± 2.0	± 2.5	± 2.9	kHz	1200bps, $\Delta f = 4.0\text{kHz}$, no AFC	
	± 2.0	± 2.5	± 3.2	kHz	2400bps, $\Delta f = 4.5\text{kHz}$, no AFC	
AFC Capture Range (AFC Closed Loop)		± 4		kHz	512bps, $\Delta f = 4.5\text{kHz}$. All at sensitivity $+3\text{dB}$ or above	
		± 3.5		kHz	1200bps, $\Delta f = 4.0\text{kHz}$. All at sensitivity $+3\text{dB}$ or above	
		± 4		kHz	2400bps, $\Delta f = 4.5\text{kHz}$. All at sensitivity $+3\text{dB}$ or above	

Receiver Characteristics (280MHz)

Receiver Characteristics (280MHz) are guaranteed over the following range of operating conditions unless otherwise stated. Characteristics are not tested but are guaranteed by characterisation test or design. All measurements made using the characterisation circuit Fig. 5. See Application Note AN137 for details of test method.

$T_{AMB} = -10^{\circ}\text{C}$ to $+55^{\circ}\text{C}$, $V_{CC1} = 1.04\text{V}$ to 2.0V , $V_{CC2} = 2.3\text{V}$ to 3.2V , $V_{CC1} < V_{CC2} - 0.8\text{V}$, carrier frequency = 280MHz, BER = 1 in 30, AFC open loop. LNA gain set such that an RF signal of -73dBm at the LNA input, offset from the LO by 4kHz, gives a typical IF signal level of 300mV p-p at TPI and TPQ. LNA noise figure $< 2\text{dB}$

Characteristic	Value			Units	Conditions	
	Min.	Typ.	Max.			
Sensitivity	-128	-129	-124	dBm	512bps, $\Delta f = 4.5\text{kHz}$	
	-127	-127	-124	dBm	1200bps, $\Delta f = 4.0\text{kHz}$	
	-127	-124	-121	dBm	2400bps, $\Delta f = 4.5\text{kHz}$. LO = -15dBm	
Intermodulation, IM3	52	57	60	dB	512bps, $\Delta f = 4.5\text{kHz}$	
	49	56	60	dB	1200bps, $\Delta f = 4.0\text{kHz}$	
	49	53.5	57	dB	2400bps, $\Delta f = 4.5\text{kHz}$. LO = -15dBm . Channel spacing 25kHz	
Adjacent Channel	62.5	74	80	dB	512bps, $\Delta f = 4.5\text{kHz}$	
	60	72	80	dB	1200bps, $\Delta f = 4.0\text{kHz}$	
	60	70	77	dB	2400bps, $\Delta f = 4.5\text{kHz}$. LO = -15dBm . Channel spacing 25kHz	
Deviation Acceptance		+1.9		kHz	512bps, $\Delta f = 4.5\text{kHz}$, no AFC	
		-2.5		kHz	512bps, $\Delta f = 4.5\text{kHz}$, no AFC	
	Up	+1.8	+3.0	+4.6	kHz	1200bps, $\Delta f = 4.0\text{kHz}$, no AFC
	Down	-2.7	-2.3	-1.7	kHz	1200bps, $\Delta f = 4.0\text{kHz}$, no AFC
	Up	+1.7	+2.5	+4.6	kHz	2400bps, $\Delta f = 4.5\text{kHz}$, no AFC
	Down	-3.0	-2.3	-1.7	kHz	2400bps, $\Delta f = 4.5\text{kHz}$, no AFC
Centre Frequency Acceptance		± 2.8		kHz	512bps, $\Delta f = 4.5\text{kHz}$, no AFC	
	± 2.0	± 2.5	± 2.9	kHz	1200bps, $\Delta f = 4.0\text{kHz}$, no AFC	
	± 2.0	± 2.5	± 3.2	kHz	2400bps, $\Delta f = 4.5\text{kHz}$, no AFC	
AFC Capture Range (AFC Closed Loop)		± 4		kHz	512bps, $\Delta f = 4.5\text{kHz}$. All at sensitivity +3dB or above	
		± 3.5		kHz	1200bps, $\Delta f = 4.0\text{kHz}$. All at sensitivity +3dB or above	
		± 4		kHz	2400bps, $\Delta f = 4.5\text{kHz}$. All at sensitivity +3dB or above	
1MHz Blocking	67	75	78	dB	512bps, $\Delta f = 4.5\text{kHz}$	
	65	75	76	dB	1200bps, $\Delta f = 4.0\text{kHz}$	
	65	75	76	dB	2400bps, $\Delta f = 4.5\text{kHz}$. LO = -15dBm	

Operation of SL6619

Low Noise Amplifier

To achieve optimum performance it is necessary to incorporate a Low Noise RF Amplifier at the front end of the receiver. This is easily biased using the on-chip voltages and current source provided. All voltages and current sources used for bias of the RF amplifier, receiver and mixers should be RF decoupled using 1nF capacitors. The receiver also requires a stable Local Oscillator at the required channel frequency.

Local Oscillator

The Local Oscillator signal is applied to the device in phase quadrature. This can be achieved with the use of two RC networks operating at their $-3\text{dB}/45^\circ$ transfer characteristic. The RC characteristics for I and Q channels are combined to give a full 90° phase differential between the LO ports of the device. Each LO port also requires an equal level of drive from the oscillator. This is achieved by forming the two RC networks into a power divider.

Gyrator Filters

The on-chip filters include an adjustable gyrator filter. This may be adjusted by changing the value of the resistor connected between pin 13 and GND. This allows adjustment of the filters' cutoff frequency and allows for compensation for possible process variations.

Audio AGC (Fig. 3)

The Audio AGC consists of a current sink which is controlled by the audio (baseband) signal. It has three parameters that may be controlled by the user. These are the attack (turn on) time, decay (duration) time and threshold level. The attack time is simply determined by the value of the external capacitor connected to TCADJ. The external capacitor is in series with an internal $100\text{k}\Omega$ resistor and the time constant of this circuit dictates the attack time of the AGC.

$$\text{i.e. } t_{\text{ATTACK}} = 100\text{k}\Omega \times C18$$

The decay time is determined by the external resistor connected in parallel with the capacitor CTC. The decay time is simply

$$t_{\text{DECAY}} = R17 \times C18$$

When a large audio (baseband) signal is incident on the input to the AGC circuit, the variable current source is turned on. This causes a voltage drop across R13. The voltage potential between V_{REF} and the voltage on pin 31 causes a current to flow in pin 30. This charges up C18 through the $100\text{k}\Omega$ internal resistor. As the voltage across the capacitor increases, a current source is turned on and this sinks current from pin 32. The current sink on pin 32 can be used to drive

the external AGC circuit by causing a PIN diode to conduct, reducing the signal to the RF amplifier.

RF AGC

The RF AGC is an automatic gain control loop that protects the mixer's RF inputs, Pins 3 and 5, from large out of band RF signals. The loop consists of an RF received signal strength indicator which detect the signal at the inputs of the mixers. This RSSI signal is then used to control the LNA current source (pin 1).

Regulator

The on-chip regulator should be used in conjunction with a suitable PNP transistor to achieve regulation. As the transistor forms part of the regulator feedback loop the transistor should exhibit the following characteristics:

$$H_{\text{FE}} > 100 \text{ for } V_{\text{CE}} > 0.1\text{V}$$

If no external transistor is used, the maximum current sourcing capability of the regulator is limited to $30\mu\text{A}$.

Automatic Frequency Control (Fig. 4)

The Automatic Frequency Control consists of a detection circuit which gives a current output at AFC OP whose magnitude and sign is a function of the difference between the local oscillator (f_{LO}) and carrier frequencies (f_{C}). This output current is then filtered by an off-chip integrating capacitor. The integrator's output voltage is used to control a voltage control crystal oscillator. This closes the AFC feedback loop giving the automatic frequency control function. For an FSK modulated incoming RF carrier, the AFC OP current's polarity is positive, i.e. current is sourced for $f_{\text{LO}} < f_{\text{C}} < f_{\text{LO}} + 4\text{kHz}$ and negative, i.e. current is sunk, for $f_{\text{LO}} > f_{\text{C}} > f_{\text{LO}} - 4\text{kHz}$. The magnitude of the AFC OP current is a function of frequency offset and the transmitted data's bit stream. If the carrier frequency, (f_{C}), equals the local oscillator frequency, (f_{LO}) then the magnitude of the current is zero.

BIT RATE FILTER CONTROL

The logic level on pin 26 controls the cutoff frequency of the 1st order bit rate for a given bit rate filter capacitor at pin 27. This allows the cutoff frequency to be changed between f_{C} , $2f_{\text{C}}$ and $0.43f_{\text{C}}$ through the logic level on pin 26. This function is achieved by changing the value of the current in the 4ϕ detector's output stage. A logic zero (0V to 0.1V) on pin 26 gives a cutoff frequency of f_{C} a logic one ($V_{\text{CC}2} - 0.3\text{V}$ to $V_{\text{CC}2}$) gives a cut off frequency of $2f_{\text{C}}$ and an open circuit at pin 26 gives a cutoff frequency of $0.43f_{\text{C}}$.

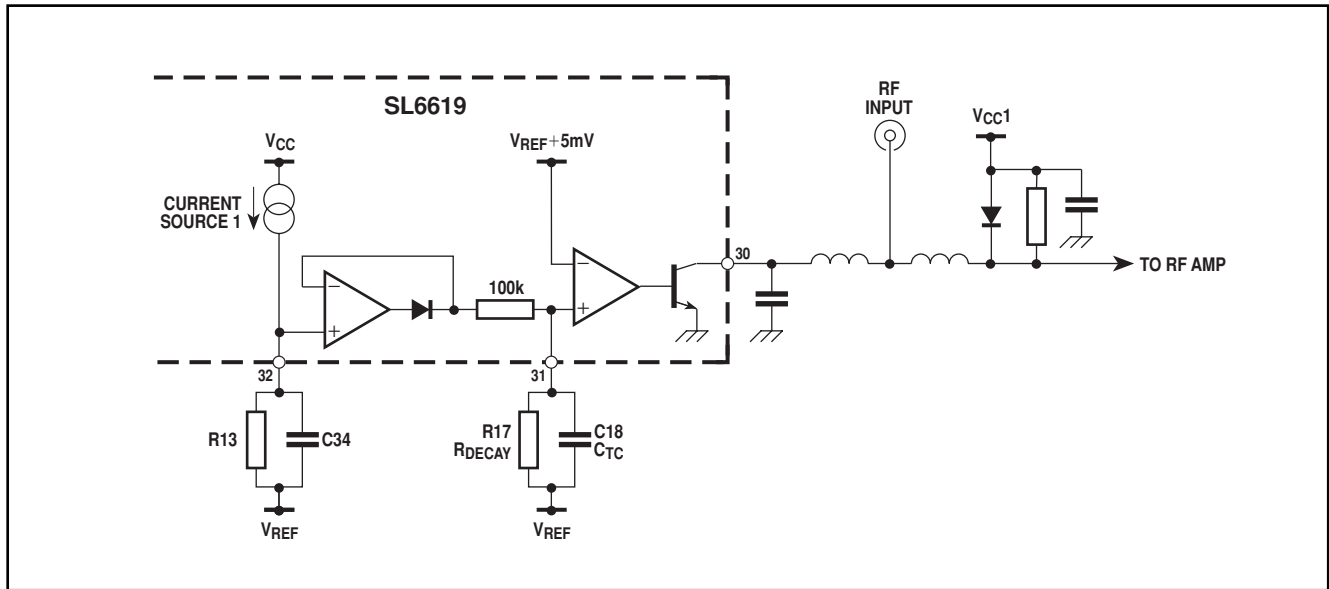

Figure 3 - AGC schematic

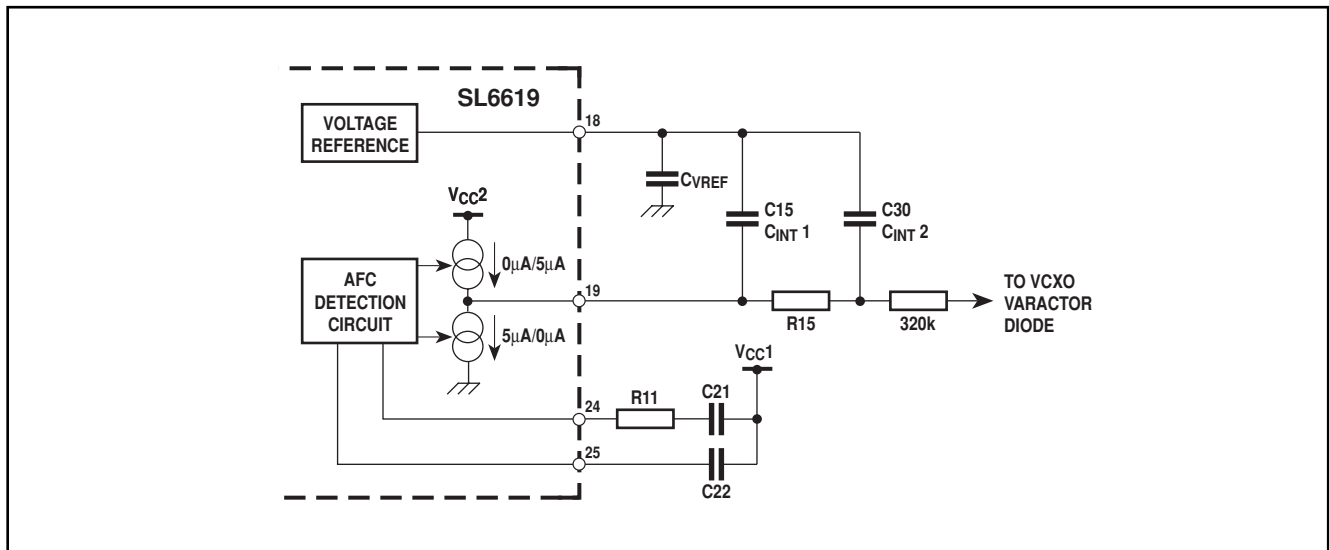

Figure 4 - AFC schematic

Peak deviation (kHz)	Baud rate (bps)	Component (Fig. 4)		
		C22	C21	R11
3.5	512, 1200, 2400	750pF	2.0nF	15kΩ
4	512, 1200, 2400	560pF	1.5nF	15kΩ
4.5	512, 1200, 2400	510pF	1.3nF	15kΩ
5	512, 1200, 2400	470pF	1.2nF	15kΩ
5.5	512, 1200, 2400	430pF	1.1nF	15kΩ

Table 2 - AFC defining components

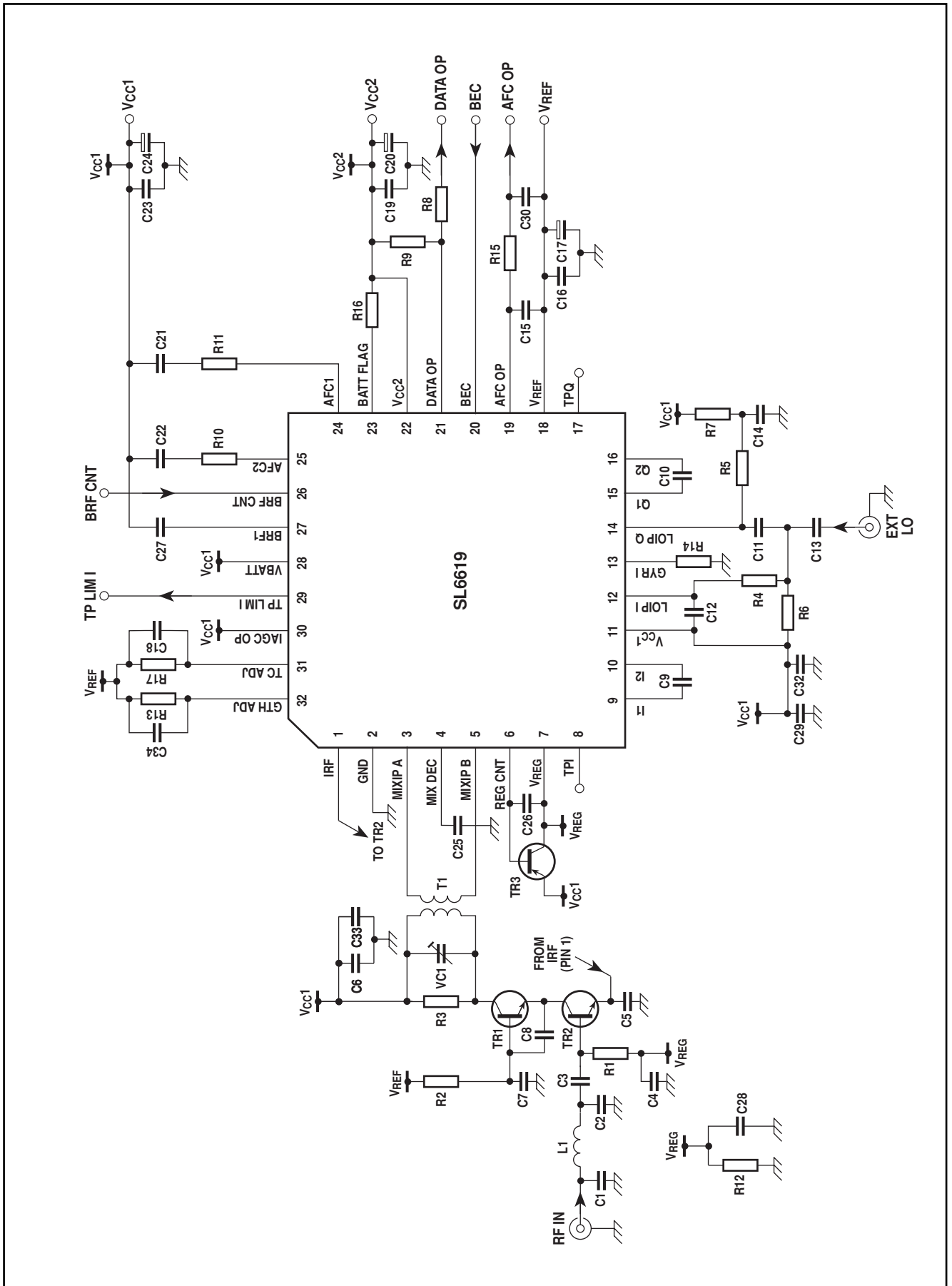

Figure 5 - SL6619 characterisation circuit (see Tables 3 and 4 for component values)

Resistors		Capacitors		Capacitors (cont.)		Inductors	
R1	4.7k Ω	C1	12pF	C18	100nF	L1	56nH
R2	4.7k Ω	C2	O/C	C19	1nF	T1	30nH 1:1, Coilcraft M1686-A
R3	2k Ω	C3	220nF	C20	2.2 μ F	Transistors	
R4	100 Ω	C4	1nF	C21	1.5nF	TR1	Toshiba 2SC5065
R5	100 Ω	C5	1nF	C22	560pF	TR2	Toshiba 2SC5065
R6	100 Ω	C6	1nF	C23	1nF	TR3	FMMT589 (Zetex ZTX550)
R7	100 Ω	C7	1nF	C24	2.2 μ F		
R8	430k Ω	C8	3.3pF	C25	100nF		
R9	220k Ω	C9	4.7nF	C26	100nF		
R10	S/C	C10	4.7nF	C27	560pF		
R11	15k Ω	C11	4.7pF	C28	1nF		
R12	2k Ω	C12	5.6pF	C29	1nF		
R13	33k Ω	C13	1nF	C30	1nF		
R14	180k Ω	C14	1nF	C32	100nF		
R15	430k Ω	C15	1nF	C33	100nF		
R16	220k Ω	C16	1nF	C34	100nF		
R17	220k Ω	C17	2.2 μ F	VC1	3-10pF		

Table 3 - Component list for 280MHz characterisation board

Resistors		Capacitors		Capacitors (cont.)		Inductors	
R1	4.7k Ω	C1	O/C	C18	100nF	L1	47nH
R2	4.7k Ω	C2	O/C	C19	1nF	T1	16nH 1:1, Coilcraft Q4123-A
R3	1.8k Ω	C3	1nF	C20	2.2 μ F	Transistors	
R4	100 Ω	C4	1nF	C21	1.5nF	TR1	Philips BFT25A
R5	100 Ω	C5	1nF	C22	560pF	TR2	Philips BFT25A
R6	100 Ω	C6	1nF	C23	1nF	TR3	FMMT589 (Zetex ZTX550)
R7	100 Ω	C7	1nF	C24	2.2 μ F		
R8	430k Ω	C8	3.3pF	C25	100nF		
R9	220k Ω	C9	4.7nF	C26	100nF		
R10	S/C	C10	4.7nF	C27	560pF		
R11	15k Ω	C11	3.9pF	C28	1nF		
R12	2k Ω	C12	3.3pF	C29	1nF		
R13	33k Ω	C13	1nF	C30	1nF		
R14	180k Ω	C14	1nF	C32	100nF		
R15	430k Ω	C15	1nF	C33	100nF		
R16	220k Ω	C16	1nF	C34	100nF		
R17	220k Ω	C17	2.2 μ F	VC1	3-10pF		

Table 4 - Component list for 450MHz characterisation board

TYPICAL DC PARAMETERS (FIGS. 6 TO 8)

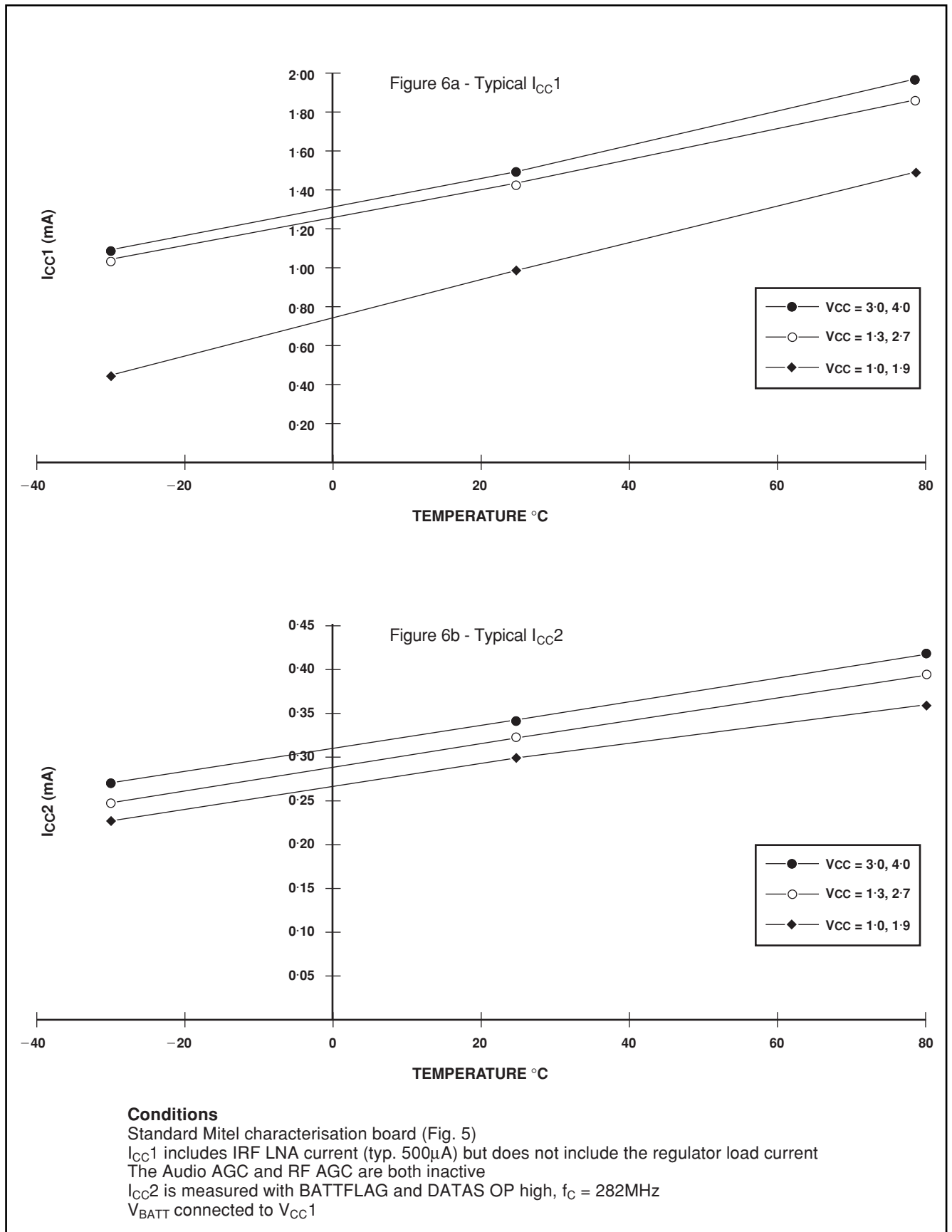

Figure 6 - Typical I_{CC1} and I_{CC2} v. supply and temperature

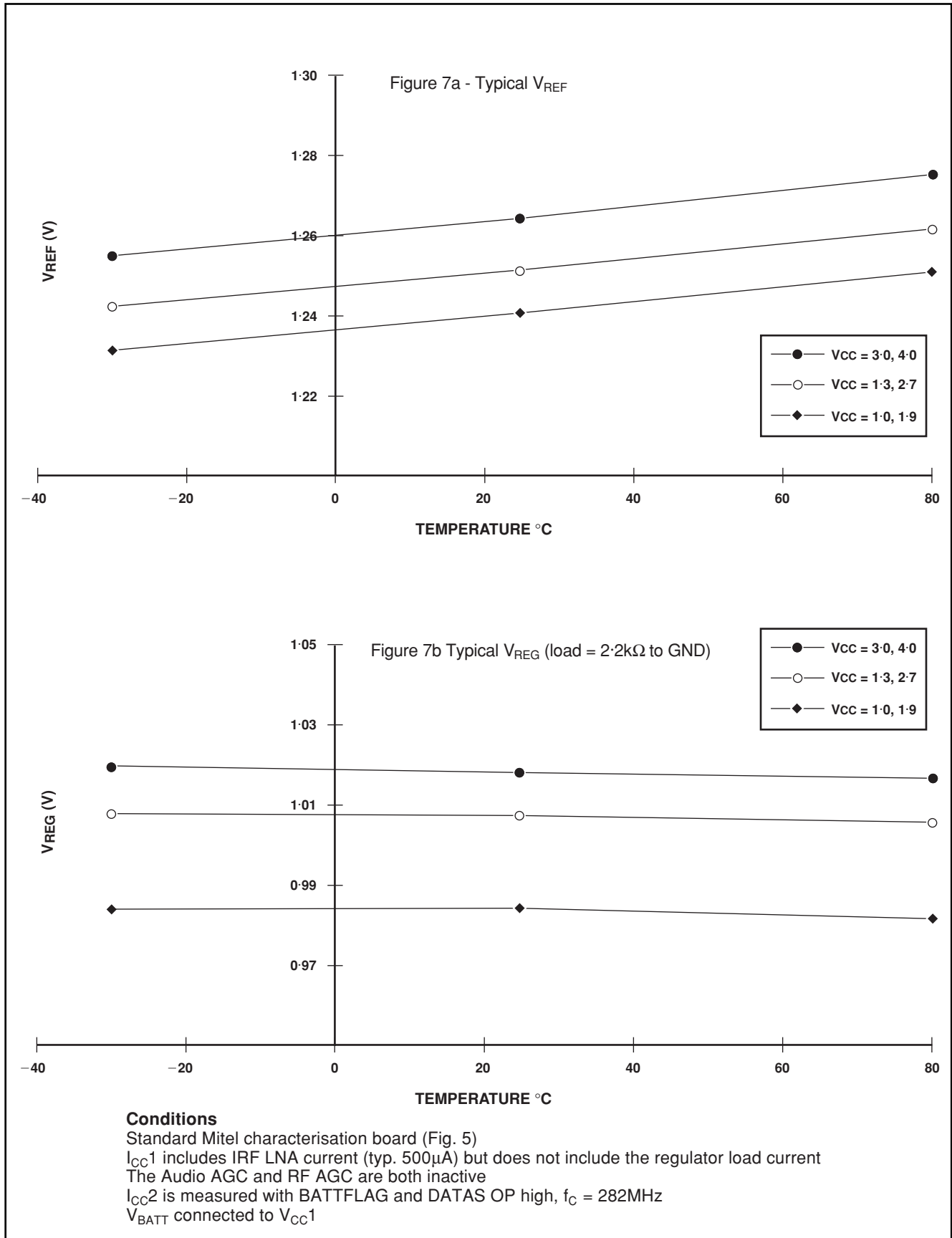

Figure 7 - Typical V_{REF} and V_{REG} v. supply and temperature

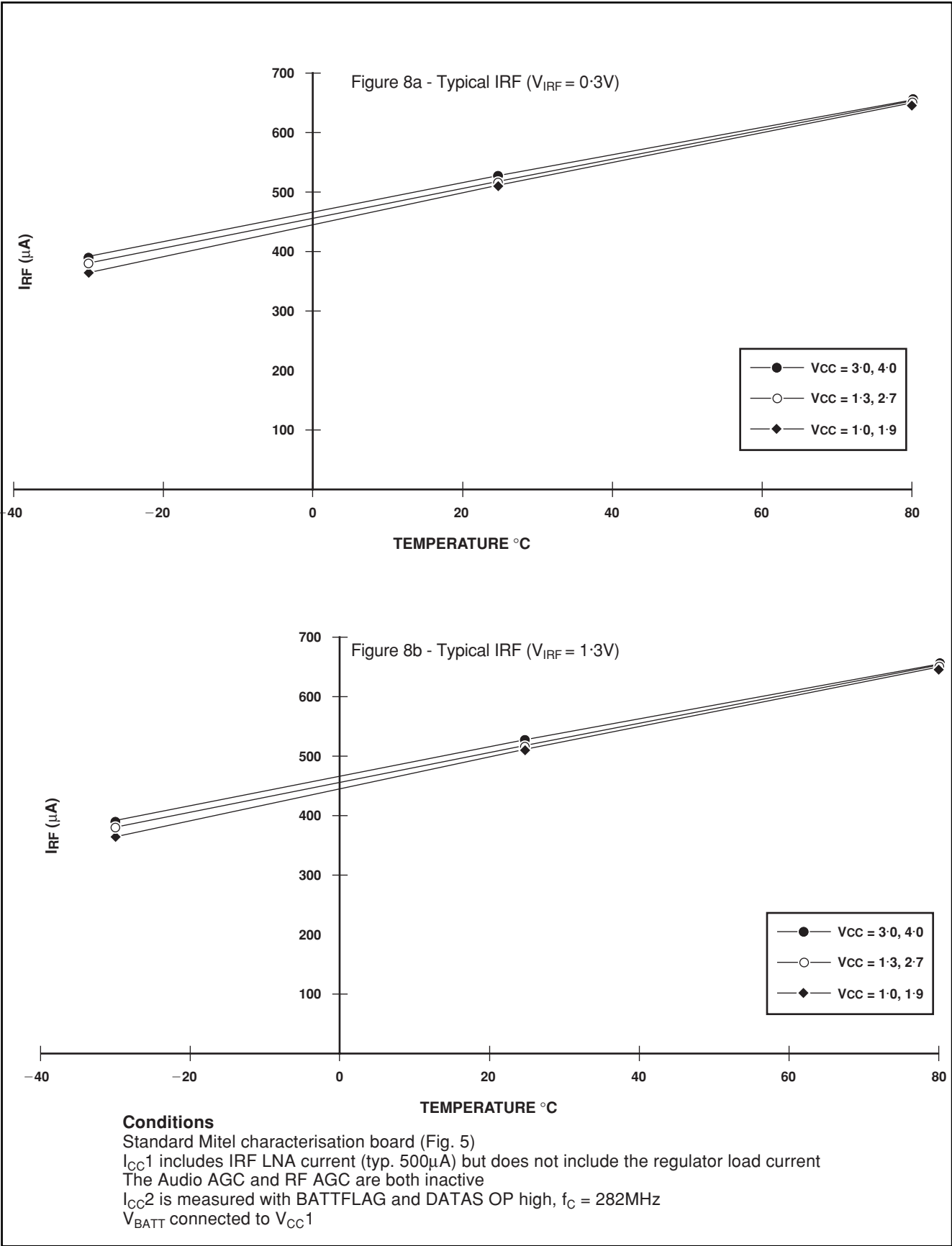

Figure 8 - Typical I_{RF} v. supply and temperature

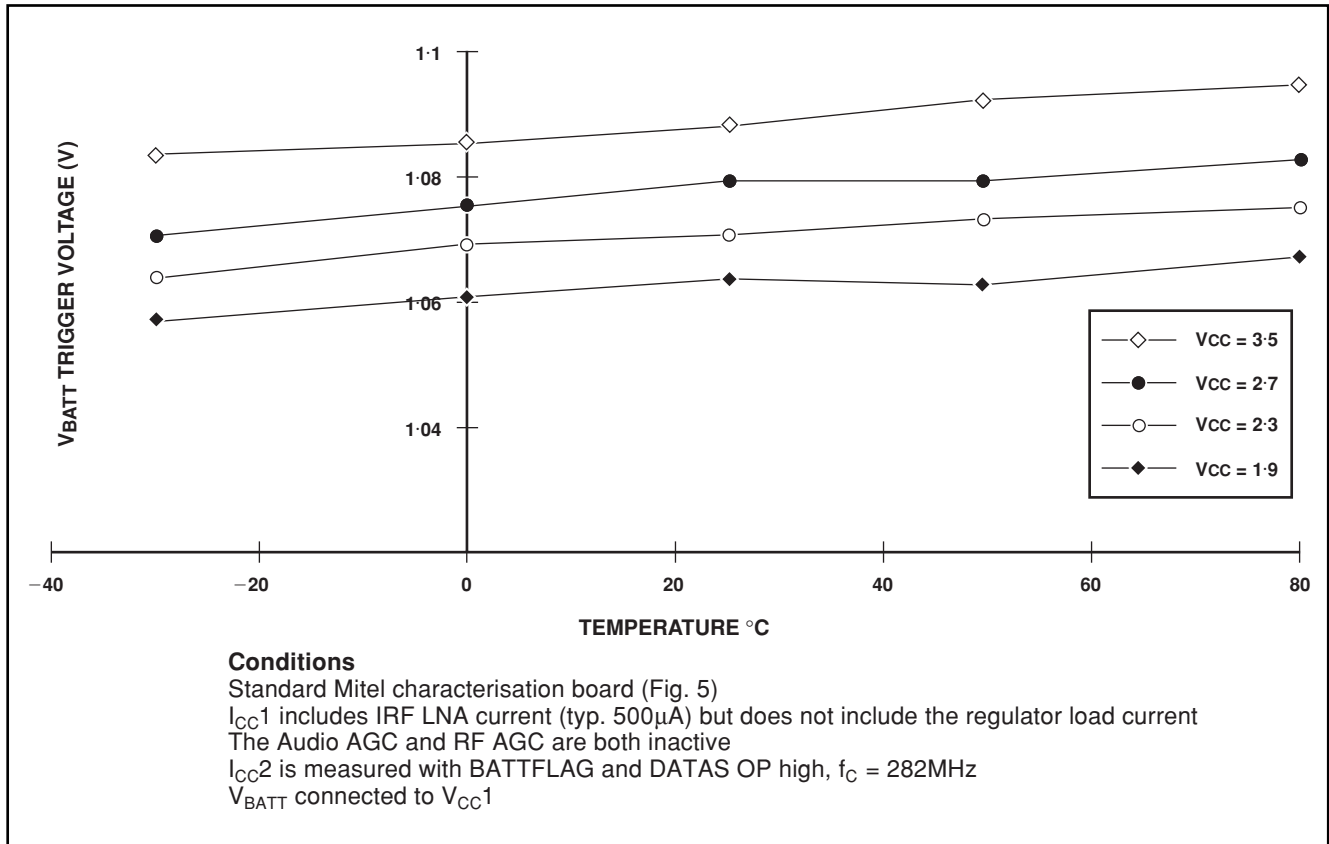

Figure 9 - Typical battery flag trigger voltage (V_{BATTFLAG} = V_{CC}/2) v. supply and temperature

TYPICAL AC PARAMETERS (FIGS. 10 TO 13)

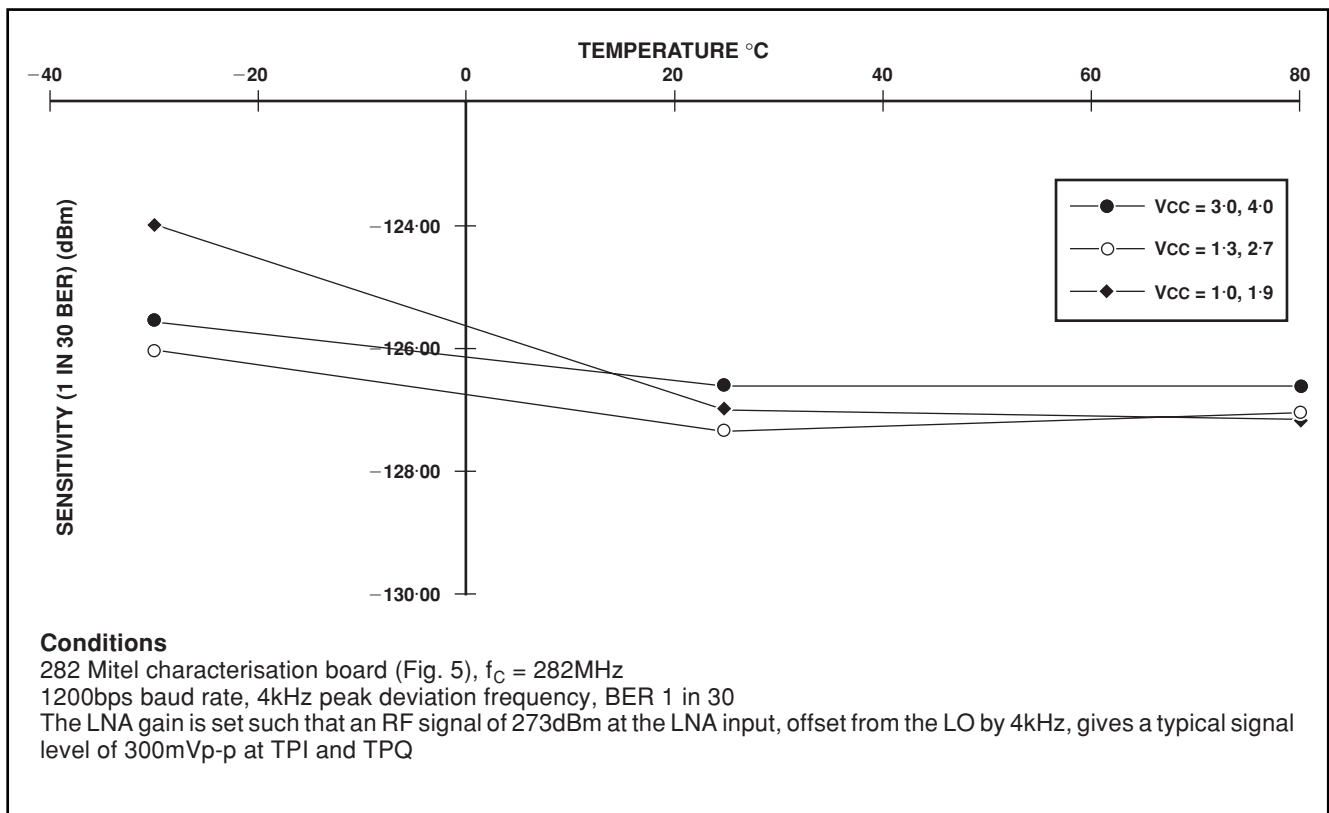

Figure 10 - Typical sensitivity v. supply and temperature

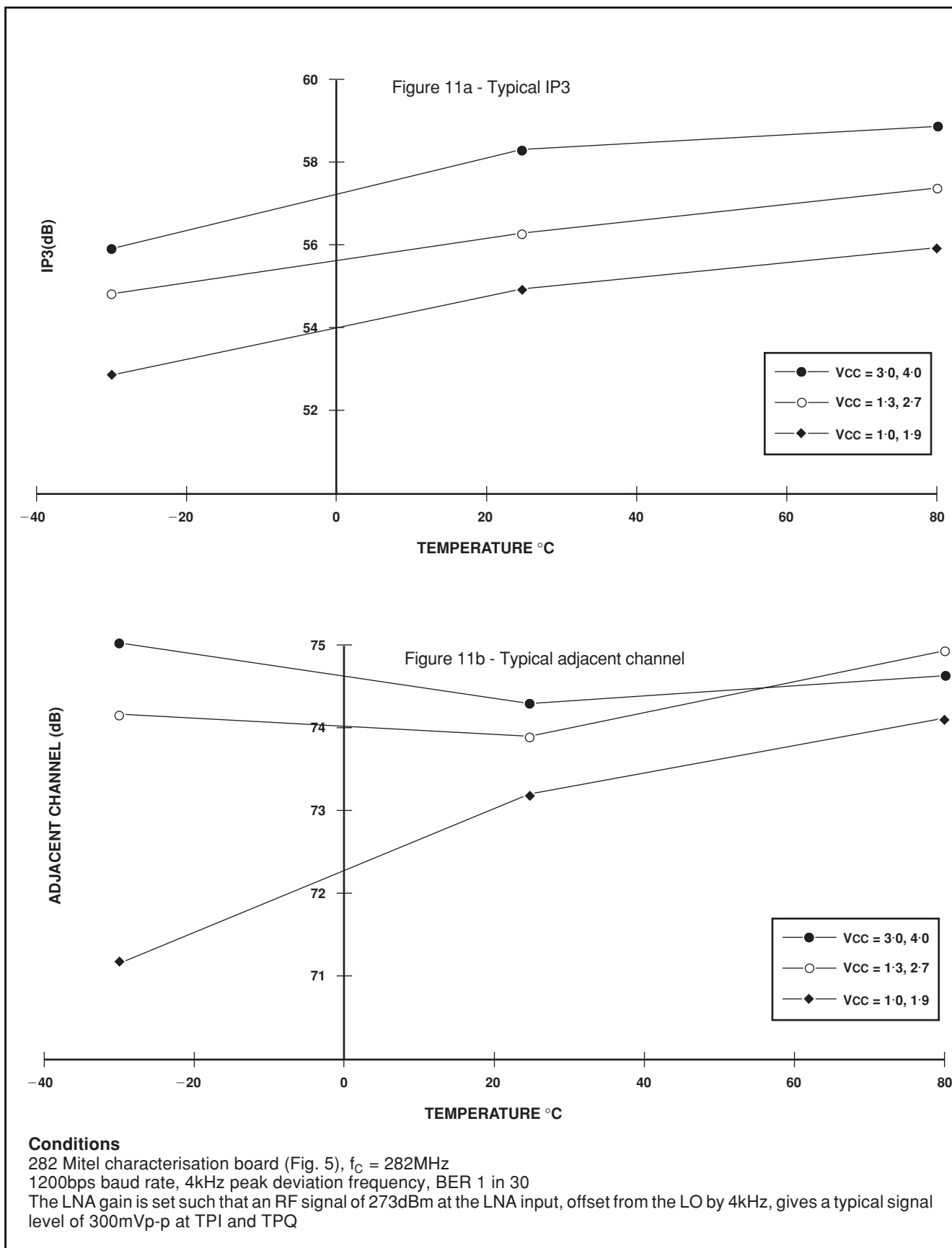

Figure 11 - Typical IP3 and adjacent channel v. supply and temperature

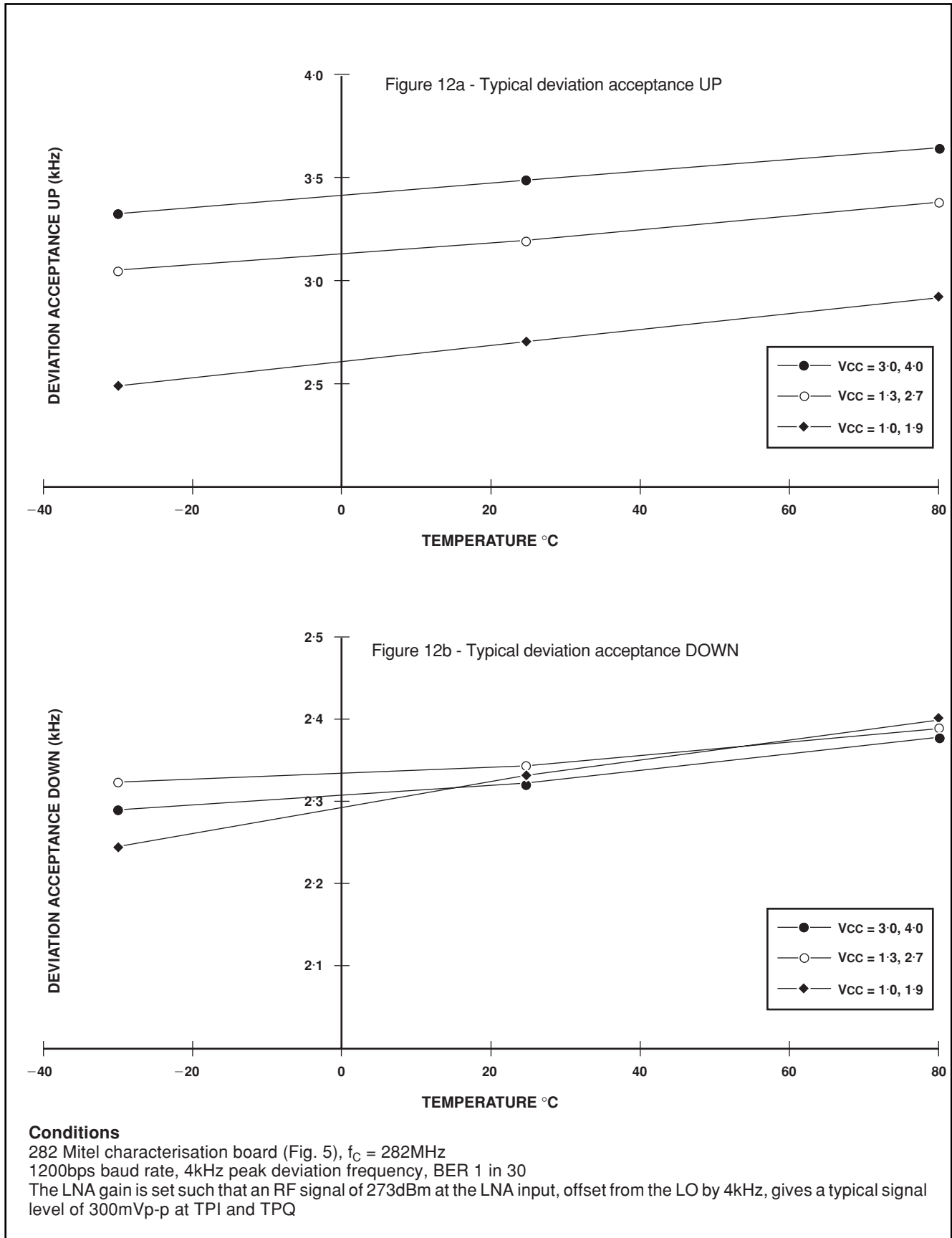
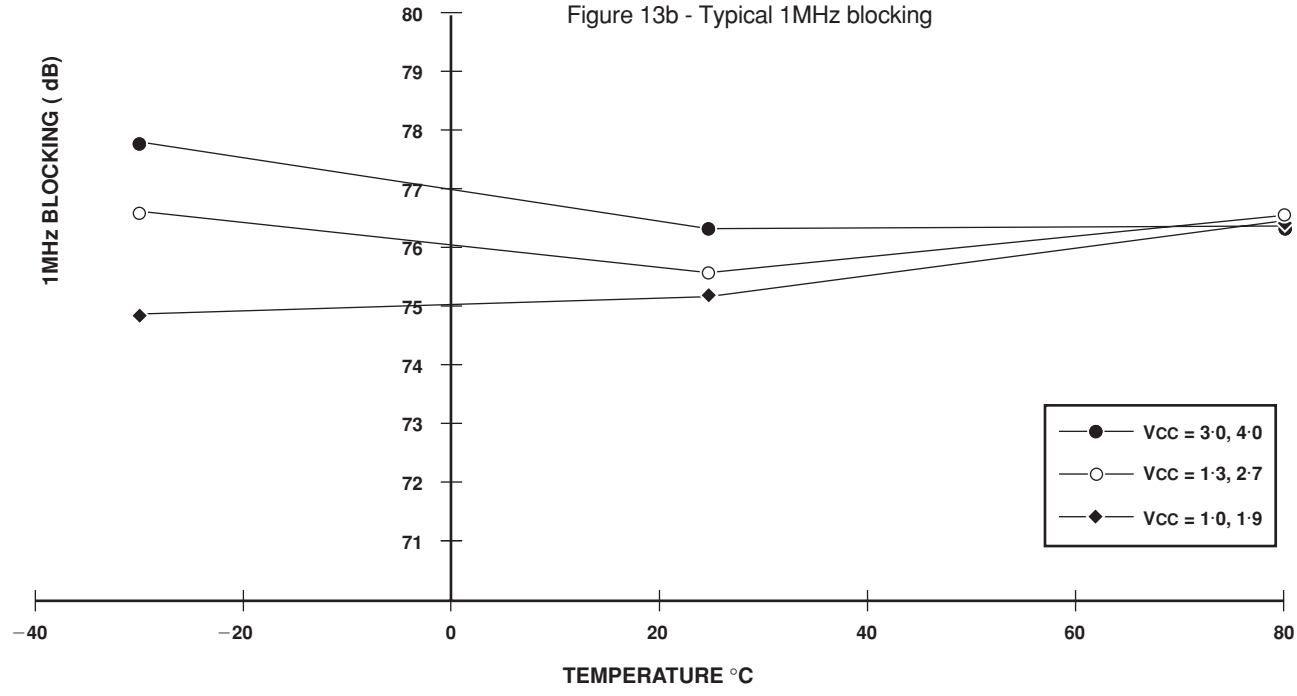
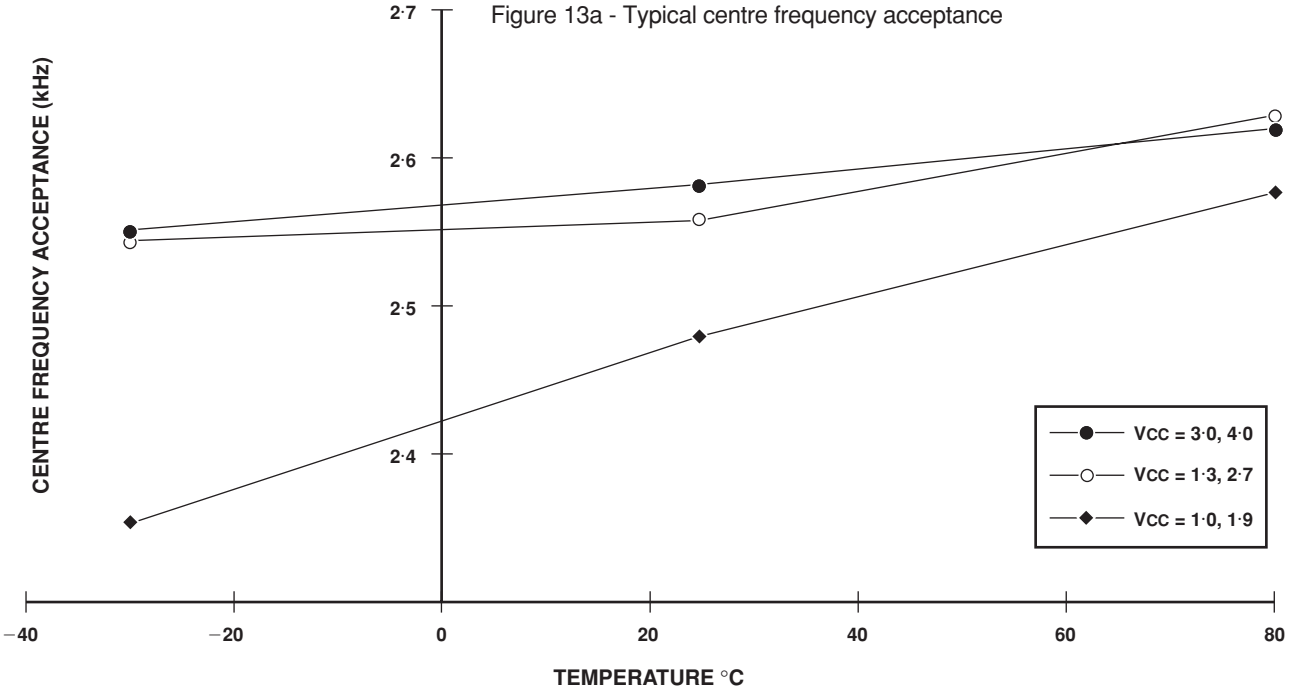
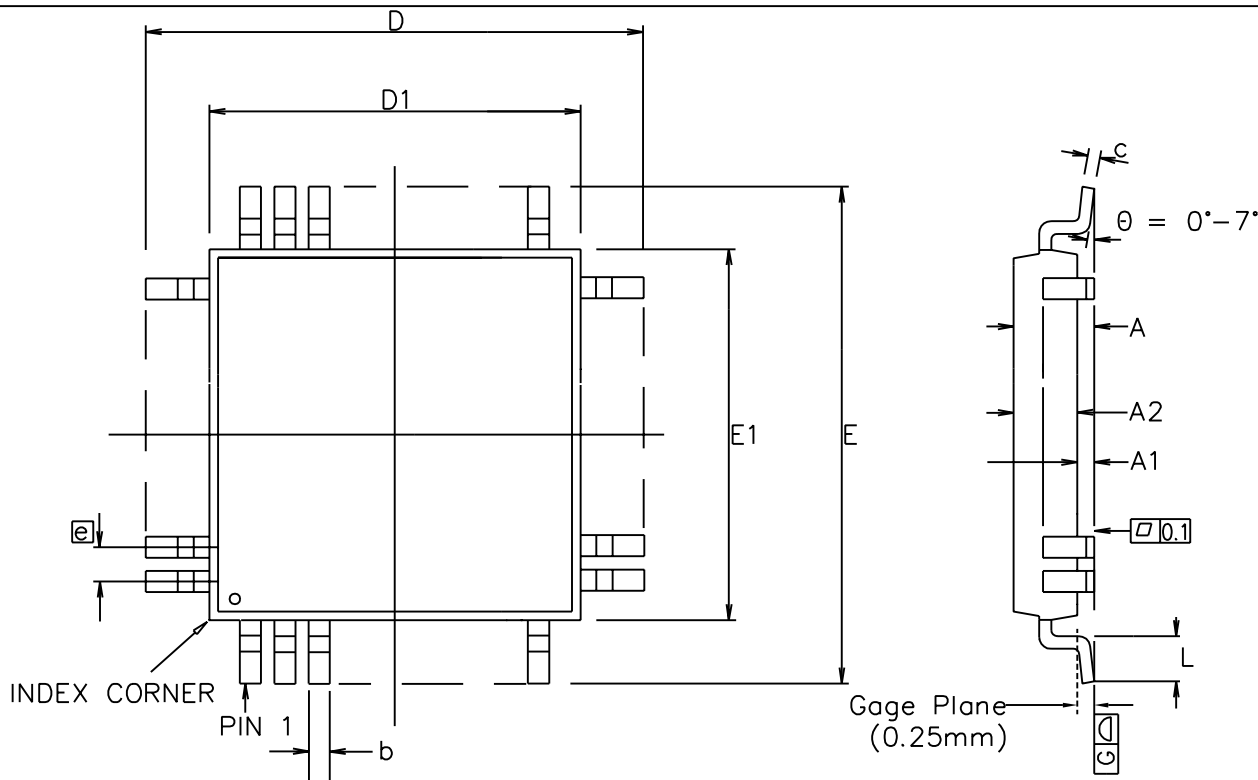

Figure 12 - Typical deviation acceptance v. supply and temperature



Conditions
282 Mitel characterisation board (Fig. 5), $f_C = 282\text{MHz}$
1200bps baud rate, 4kHz peak deviation frequency, BER 1 in 30
The LNA gain is set such that an RF signal of 273dBm at the LNA input, offset from the LO by 4kHz, gives a typical signal level of 300mVp-p at TPI and TPQ

Figure 13 - Typical centre frequency acceptance and 1MHz blocking v. supply and temperature



Symbol	Control Dimensions in millimetres		Altern. Dimensions in inches	
	MIN	MAX	MIN	MAX
A	---	1.20	---	0.047
A1	0.05	0.15	0.002	0.006
A2	0.95	1.05	0.037	0.041
D	9.00 BSC		0.354 BSC	
D1	7.00 BSC		0.276 BSC	
E	9.00 BSC		0.354 BSC	
E1	7.00 BSC		0.276 BSC	
L	0.45	0.75	0.018	0.030
e	0.80 BSC		0.031 BSC	
b	0.30	0.45	0.012	0.018
c	0.09	0.20	0.004	0.008
Pin features				
N	32			
ND	8			
NE	8			
NOTE	SQUARE			

Conforms to JEDEC MS-026 ABA Iss. C

Notes:

1. Pin 1 indicator may be a corner chamfer, dot or both.
2. Controlling dimensions are in millimeters.
3. The top package body size may be smaller than the bottom package body size by a max. of 0.15 mm.
4. Dimension D1 and E1 do not include mould protusion.
5. Dimension b does not include dambar protusion.
6. Coplanarity, measured at seating plane G, to be 0.10 mm max.

This drawing supersedes 418/ED/51612/001 (Swindon)

© Zarlink Semiconductor 2002 All rights reserved.					Package Code	QD
ISSUE	1	2	3		Previous package codes	Package Outline for 32 lead TQFP (7 x 7 x 1.0mm) 2.0mm Footprint
ACN	201348	207076	212439		TP / F	
DATE	25Oct96	6Jul99	25Mar02			
APPRD.					GPD00233	



**For more information about all Zarlink products
visit our Web Site at
www.zarlink.com**

Information relating to products and services furnished herein by Zarlink Semiconductor Inc. or its subsidiaries (collectively "Zarlink") is believed to be reliable. However, Zarlink assumes no liability for errors that may appear in this publication, or for liability otherwise arising from the application or use of any such information, product or service or for any infringement of patents or other intellectual property rights owned by third parties which may result from such application or use. Neither the supply of such information or purchase of product or service conveys any license, either express or implied, under patents or other intellectual property rights owned by Zarlink or licensed from third parties by Zarlink, whatsoever. Purchasers of products are also hereby notified that the use of product in certain ways or in combination with Zarlink, or non-Zarlink furnished goods or services may infringe patents or other intellectual property rights owned by Zarlink.

This publication is issued to provide information only and (unless agreed by Zarlink in writing) may not be used, applied or reproduced for any purpose nor form part of any order or contract nor to be regarded as a representation relating to the products or services concerned. The products, their specifications, services and other information appearing in this publication are subject to change by Zarlink without notice. No warranty or guarantee express or implied is made regarding the capability, performance or suitability of any product or service. Information concerning possible methods of use is provided as a guide only and does not constitute any guarantee that such methods of use will be satisfactory in a specific piece of equipment. It is the user's responsibility to fully determine the performance and suitability of any equipment using such information and to ensure that any publication or data used is up to date and has not been superseded. Manufacturing does not necessarily include testing of all functions or parameters. These products are not suitable for use in any medical products whose failure to perform may result in significant injury or death to the user. All products and materials are sold and services provided subject to Zarlink's conditions of sale which are available on request.

Purchase of Zarlink's I²C components conveys a licence under the Philips I²C Patent rights to use these components in and I²C System, provided that the system conforms to the I²C Standard Specification as defined by Philips.

Zarlink, ZL and the Zarlink Semiconductor logo are trademarks of Zarlink Semiconductor Inc.

Copyright Zarlink Semiconductor Inc. All Rights Reserved.

TECHNICAL DOCUMENTATION - NOT FOR RESALE
