

SN54ALS832A, SN54AS832B, SN74ALS832A, SN74AS832B HEX 2-INPUT OR DRIVERS

SDAS017C - DECEMBER 1982 - REVISED JANUARY 1995

- High Capacitive-Drive Capability
- 'ALS832A Has Typical Delay Time of 4.8 ns ($C_L = 50$ pF) and Typical Power Dissipation of 4.5 mW Per Gate
- 'AS832B Has Typical Delay Time of 3.2 ns ($C_L = 50$ pF) and Typical Power Dissipation of Less Than 13 mW Per Gate
- Package Options Include Plastic Small-Outline (DW) Packages, Ceramic Chip Carriers (FK), and Standard Plastic (N) and Ceramic (J) 300-mil DIPs

description

These devices contain six independent 2-input OR drivers. They perform the Boolean functions $Y = A + B$ or $Y = \bar{A} \cdot \bar{B}$ in positive logic.

The SN54ALS832A and SN54AS832B are characterized for operation over the full military temperature range of -55°C to 125°C . The SN74ALS832A and SN74AS832B are characterized for operation from 0°C to 70°C .

FUNCTION TABLE
(each driver)

INPUTS		OUTPUT
A	B	Y
H	X	H
X	H	H
L	L	L

logic symbol

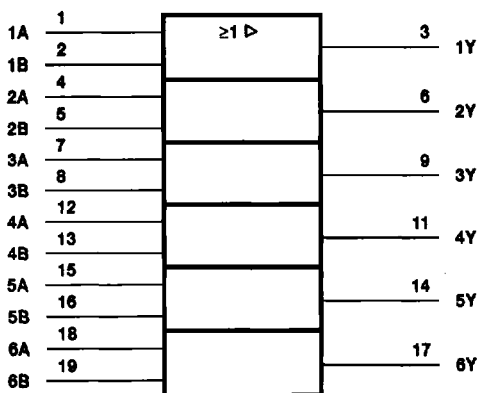

† This symbol is in accordance with ANSI/IEEE Std 91-1984 and IEC Publication 617-12.

SN54ALS832A, SN54AS832B ... J PACKAGE
SN74ALS832A, SN74AS832B ... DW OR N PACKAGE
(TOP VIEW)

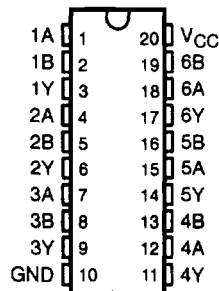

SN54ALS832A, SN54AS832B ... FK PACKAGE
(TOP VIEW)

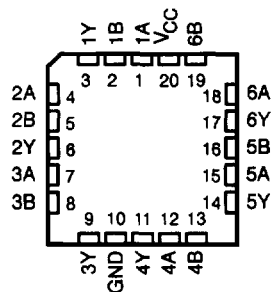

logic diagram (positive logic)

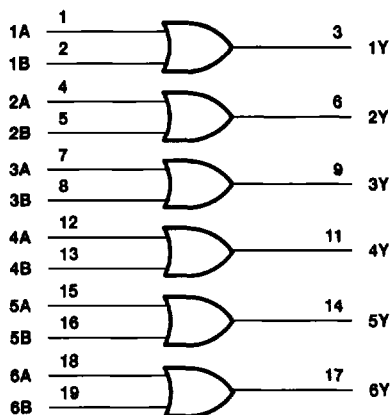

PRODUCTION DATA information is current as of publication date. Products conform to specifications per the terms of Texas Instruments standard warranty. Production processing does not necessarily include testing of all parameters.

 **TEXAS
INSTRUMENTS**

POST OFFICE BOX 655303 • DALLAS, TEXAS 75265

Copyright © 1995, Texas Instruments Incorporated

SN54ALS832A, SN54AS832B, SN74ALS832A, SN74AS832B HEX 2-INPUT OR DRIVERS

SDAS017C - DECEMBER 1982 - REVISED JANUARY 1995

absolute maximum ratings over operating free-air temperature range (unless otherwise noted)†

Supply voltage, V_{CC}	7 V
Input voltage, V_I	7 V
Operating free-air temperature range, T_A : SN54ALS832A	-55°C to 125°C
SN74ALS832A	0°C to 70°C
Storage temperature range	-65°C to 150°C

† Stresses beyond those listed under "absolute maximum ratings" may cause permanent damage to the device. These are stress ratings only, and functional operation of the device at these or any other conditions beyond those indicated under "recommended operating conditions" is not implied. Exposure to absolute-maximum-rated conditions for extended periods may affect device reliability.

recommended operating conditions

		SN54ALS832A			SN74ALS832A			UNIT
		MIN	NOM	MAX	MIN	NOM	MAX	
V_{CC}	Supply voltage	4.5	5	5.5	4.5	5	5.5	V
V_{IH}	High-level input voltage	2			2			V
V_{IL}	Low-level input voltage			0.7			0.8	V
I_{OH}	High-level output current			-12			-15	mA
I_{OL}	Low-level output current			12			24	mA
T_A	Operating free-air temperature	-55		125	0		70	°C

electrical characteristics over recommended operating free-air temperature range (unless otherwise noted)

PARAMETER	TEST CONDITIONS	SN54ALS832A			SN74ALS832A			UNIT
		MIN	TYP‡	MAX	MIN	TYP‡	MAX	
V_{IK}	$V_{CC} = 4.5 V$, $I_I = -18 mA$			-1.5			-1.5	V
V_{OH}	$V_{CC} = 4.5 V$ to $5.5 V$, $I_{OH} = -0.4 mA$	$V_{CC} - 2$			$V_{CC} - 2$			V
	$V_{CC} = 4.5 V$	$I_{OH} = -3 mA$	2.4	3.2	2.4	3.2		
		$I_{OH} = -12 mA$	2					
V_{OL}	$V_{CC} = 4.5 V$	$I_{OH} = -15 mA$	2					
		$I_{OL} = 12 mA$	0.25	0.4	0.25	0.4	V	
		$I_{OL} = 24 mA$	0.35			0.5		
I_I	$V_{CC} = 5.5 V$, $V_I = 7 V$			0.1			0.1	mA
I_{IH}	$V_{CC} = 5.5 V$, $V_I = 2.7 V$			20			20	μA
I_{IL}	$V_{CC} = 5.5 V$, $V_I = 0.4 V$			-0.1			-0.1	mA
$I_{OS}^§$	$V_{CC} = 5.5 V$, $V_O = 2.25 V$	-20		-112	-30		-112	mA
I_{CCH}	$V_{CC} = 5.5 V$, $V_I = 4.5 V$		6	9		6	9	mA
I_{CCL}	$V_{CC} = 5.5 V$, $V_I = 0$		9.5	16		9.5	16	mA

‡ All typical values are at $V_{CC} = 5 V$, $T_A = 25°C$.

§ The output conditions have been chosen to produce a current that closely approximates one half of the true short-circuit output current, I_{OS} .



POST OFFICE BOX 655303 • DALLAS, TEXAS 75265

SN54ALS832A, SN54AS832B, SN74ALS832A, SN74AS832B HEX 2-INPUT OR DRIVERS

SDAS017C - DECEMBER 1982 - REVISED JANUARY 1995

switching characteristics (see Figure 1)

PARAMETER	FROM (INPUT)	TO (OUTPUT)	V _{CC} = 4.5 V to 5.5 V, C _L = 50 pF, R _L = 500 Ω, T _A = MIN to MAX†				UNIT
			SN54ALS832A		SN74ALS832A		
			MIN	MAX	MIN	MAX	
t _{PLH}	A or B	Y	1	13	2	9	ns
t _{PHL}			1	11	1	8	

† For conditions shown as MIN or MAX, use the appropriate value specified under recommended operating conditions.

absolute maximum ratings over operating free-air temperature range (unless otherwise noted)‡

Supply voltage, V _{CC}	7 V
Input voltage, V _I	7 V
Operating free-air temperature range, T _A : SN54AS832B	-55°C to 125°C
SN74AS832B	0°C to 70°C
Storage temperature range	-65°C to 150°C

‡ Stresses beyond those listed under "absolute maximum ratings" may cause permanent damage to the device. These are stress ratings only, and functional operation of the device at these or any other conditions beyond those indicated under "recommended operating conditions" is not implied. Exposure to absolute-maximum-rated conditions for extended periods may affect device reliability.

recommended operating conditions§

		SN54AS832B			SN74AS832B			UNIT
		MIN	NOM	MAX	MIN	NOM	MAX	
V _{CC}	Supply voltage	4.5	5	5.5	4.5	5	5.5	V
V _{IH}	High-level input voltage	2			2			V
V _{IL}	Low-level input voltage	0.8			0.8			V
I _{OH}	High-level output current	-40			-48			mA
I _{OL}	Low-level output current	40			48			mA
T _A	Operating free-air temperature	-55	125		0	70		°C

§ These high sink- or source-current devices are not recommended for use above 40 MHz.



POST OFFICE BOX 655303 • DALLAS, TEXAS 75265

2-627

SN54ALS832A, SN54AS832B, SN74ALS832A, SN74AS832B HEX 2-INPUT OR DRIVERS

SDAS017C - DECEMBER 1982 - REVISED JANUARY 1985

electrical characteristics over recommended operating free-air temperature range (unless otherwise noted)

PARAMETER	TEST CONDITIONS	SN54AS832B		SN74AS832B		UNIT		
		MIN	TYP†	MAX	MIN		TYP†	MAX
V_{IK}	$V_{CC} = 4.5 V$, $I_I = -18 mA$			-1.2			V	
V_{OH}	$V_{CC} = 4.5 V$ to $5.5 V$, $I_{OH} = -2 mA$	$V_{CC} - 2$		$V_{CC} - 2$		V		
	$V_{CC} = 4.5 V$	$I_{OH} = -3 mA$	2.4	3.2	2.4		3.2	
		$I_{OH} = -40 mA$	2					
V_{OL}	$V_{CC} = 4.5 V$	$I_{OL} = 40 mA$	0.25	0.5			V	
		$I_{OL} = 48 mA$			0.35	0.5		
I_I	$V_{CC} = 5.5 V$, $V_I = 7 V$			0.1	0.1		mA	
I_{IH}	$V_{CC} = 5.5 V$, $V_I = 2.7 V$			20	20		μA	
I_{IL}	$V_{CC} = 5.5 V$, $V_I = 0.4 V$			-0.5	-0.5		mA	
$I_{O\ddagger}$	$V_{CC} = 5.5 V$, $V_O = 2.25 V$	-50	-200	-50	-200		mA	
I_{CCH}	$V_{CC} = 5.5 V$, $V_I = 4.5 V$			11	17	11	17	mA
I_{CCL}	$V_{CC} = 5.5 V$, $V_I = 0$			22	36	22	36	mA

† All typical values are at $V_{CC} = 5 V$, $T_A = 25^\circ C$.

‡ The output conditions have been chosen to produce a current that closely approximates one half of the true short-circuit output current, I_{OS} .

switching characteristics (see Figure 1)

PARAMETER	FROM (INPUT)	TO (OUTPUT)	$V_{CC} = 4.5 V$ to $5.5 V$, $C_L = 50 pF$, $R_L = 500 \Omega$, $T_A = MIN$ to MAX §				UNIT
			SN54AS832B		SN74AS832B		
			MIN	MAX	MIN	MAX	
t_{PLH}	A or B	Y	1	7.5	1	6.3	ns
t_{PHL}			1	7	1	6.3	

§ For conditions shown as MIN or MAX, use the appropriate value specified under recommended operating conditions.



POST OFFICE BOX 855303 • DALLAS, TEXAS 75285

PARAMETER MEASUREMENT INFORMATION
SERIES 54ALS/74ALS AND 54AS/74AS DEVICES

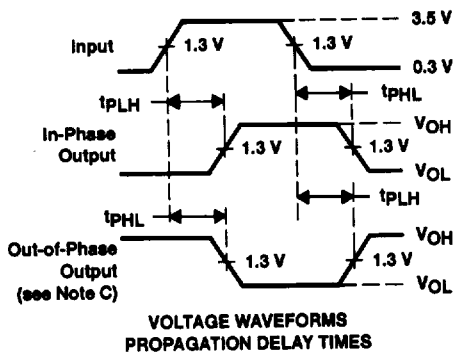
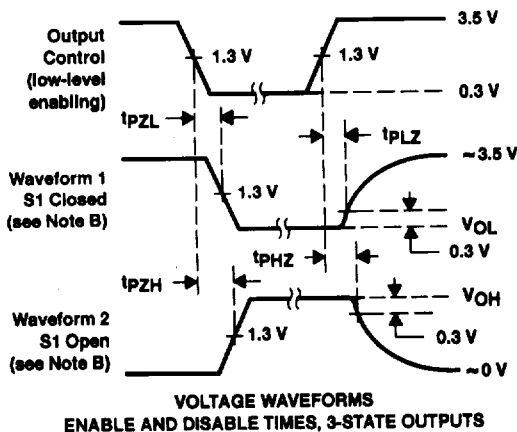
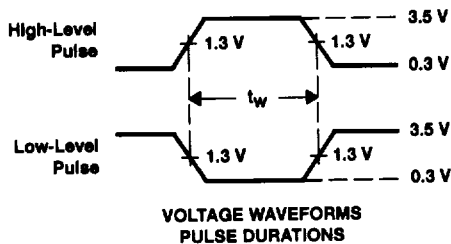
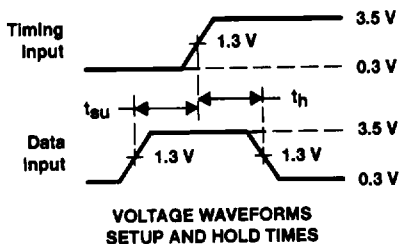
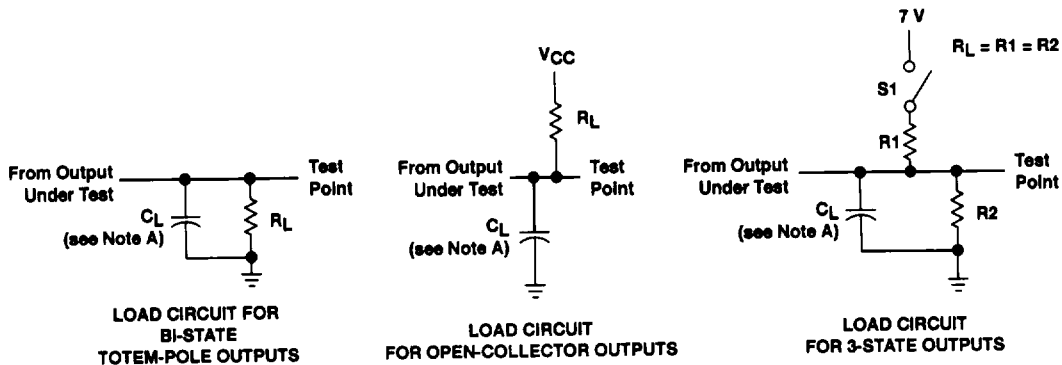

- NOTES: A. C_L includes probe and jig capacitance.
B. Waveform 1 is for an output with internal conditions such that the output is low except when disabled by the output control. Waveform 2 is for an output with internal conditions such that the output is high except when disabled by the output control.
C. When measuring propagation delay items of 3-state outputs, switch S_1 is open.
D. All input pulses have the following characteristics: $PRR \leq 1$ MHz, $t_r = t_f = 2$ ns, duty cycle = 50%.
E. The outputs are measured one at a time with one transition per measurement.

Figure 1. Load Circuits and Voltage Waveforms