

### HCSL 7 x 5mm 2.5V Oscillator

Freq: 0.016 MHz to 670 MHz

Rev. 06/30/2015

#### Features

- ULTRA Low Jitter
- Low Cost
- XPRESS Delivery
- Frequency Resolution to six decimal places
- Stabilities to  $\pm 20$  PPM
- 20 to +70°C or -40 to +85°C operating temperatures
- Tri-State Enable / Disable Feature
- Industry Standard Package, Footprint & Pin-Out
- Fully RoHS compliant
- Gold over Nickel Termination Finish
- Serial ID with Comprehensive Traceability



#### Applications

- ANY application requiring a high performance HCSL oscillator
- SONET
- Ethernet
- Storage Area Network
- Broadband Access
- Microprocessors / DSP / FPGA
- Industrial Controllers
- Test and Measurement Equipment

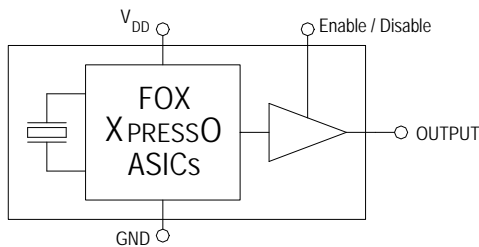

For more information -- Click on the drawing

#### Description

The Fox XpressO-ULTRA Crystal Oscillator is a breakthrough in configurable Frequency Control Solutions. XpressO-ULTRA utilizes a family of proprietary ASICs, designed and developed by Fox, with a key focus on noise reduction technologies.

The 4<sup>th</sup> order Delta Sigma Modulator reduces noise to the levels that are comparable to traditional Bulk Quartz and SAW oscillators. The ASICs family has the ability to select the output type and supply voltage.

With the XpressO-ULTRA lead-time, low cost, low noise, wide frequency range, excellent ambient performance, XpressO-ULTRA is an excellent choice over the conventional technologies.

Finished XpressO-ULTRA parts are 100% final tested.

#### Contents

	page
Model Selection & Part Number Guide	2
Electrical Characteristic	3
Absolute Maximums	3
Output Wave Characteristics	4
Phase Noise	5
Jitter	5
Pin Assignment	6
Recommended Circuit	6
Reflow	6
Mechanical Drawing and Pad Layout	7
Tape and Reel Specification	8
Label	8
Traceability – LOT Number & Serial Identification	9
Mechanical Test	10
Other XpressO Series Links	11
Fox Contact Information	11

**Model Selection Guide & Fox Part Number**

**STEP #1:** Customer selects the Model Description and provides to Fox Customer Service

Model Description

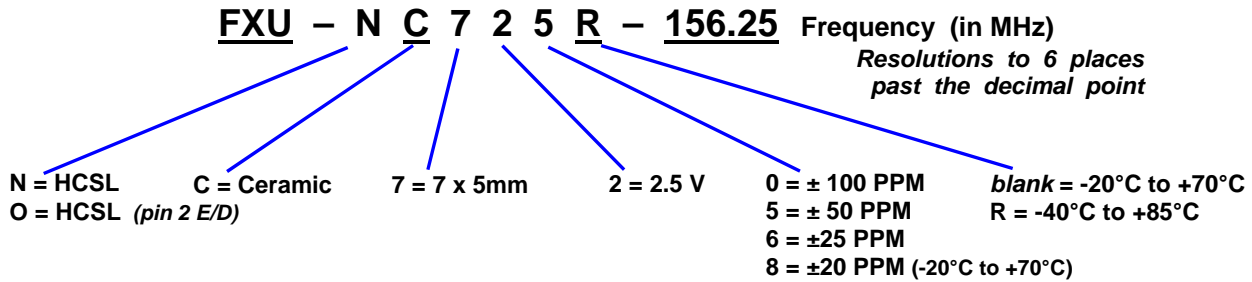

**STEP #2:** The Fox Customer Service team provides a customer specific Part Number for use on their Bill Of Materials (BOM).

Fox Part Number (The assigned Fox Part Number must be on the BOM – not the above Model Description)  
(This will ensure receipt of the proper part)

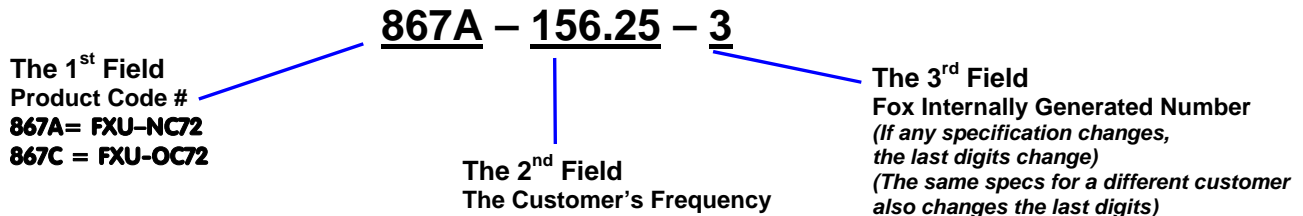

This example, **FXU-NC725R-156.25** = HCSL Output, Ceramic, 7 x 5mm Package, 2.5V, ±50 PPM Stability, -40 to +85°C Temperature Range, at 156.25 MHz

<b>Electrical Characteristics</b>			
<b>Parameters</b>	<b>Symbol</b>	<b>Condition</b>	<b>Maximum Value</b> (unless otherwise noted)
Frequency Range	F <sub>O</sub>		0.016 MHz to 670 MHz
Frequency Stability <sup>1</sup>		0.016 MHz to 670 MHz	100, 50, 25, 20 <sup>2</sup> PPM
Temperature Range	T <sub>O</sub>	Standard operating Optional operating	-20°C to +70°C -40°C to +85°C
	T <sub>STG</sub>	Storage	-55°C to +125°C
Supply Voltage	V <sub>DD</sub>	Standard	2.5 V ± 5%
Input Current (@ Standard Load)	I <sub>DD</sub>	0.016 MHz to 400 MHz 400+ MHz to 670 MHz	102 mA 112 mA
Output Load		Standard	50 Ohms to GND TYP.
Start-Up Time	T <sub>S</sub>		10 mS
Output Enable / Disable Time			100 nS
Moisture Sensitivity Level	MSL	JEDEC J-STD-020	1
Termination Finish			Au

Note 1 – Stability is inclusive of 25°C tolerance, operating temperature range, input voltage change, load change, 1 year aging at 25°C, shock and vibration.

2 – ±20 PPM stability -20°C to +70°C only.

<b>Absolute Maximum Ratings</b> (Useful life may be impaired. For user guidelines only, not tested)			
<b>Parameters</b>	<b>Symbol</b>	<b>Condition</b>	<b>Maximum Value</b> (unless otherwise noted)
Input Voltage	V <sub>DD</sub>		-0.5V to +5.0V
Operating Temperature	T <sub>AMAX</sub>		-55°C to +85°C
Storage Temperature	T <sub>STG</sub>		-55°C to +125°C
Junction Temperature			125°C
ESD Sensitivity	HBM	Human Body Model	1 kV

Output Wave Characteristics			
Parameters	Symbol	Condition	Maximum Value (unless otherwise noted)
Low Output Voltage	$V_{OL}$	0.016 MHz to 670 MHz	0 V to 0.2 V
High Output Voltage	$V_{OH}$	0.016 MHz to 670 MHz	0.55 V to 0.95 V
Output Symmetry		0.016 MHz to 670 MHz 50% $V_{P-P}$	45% ~ 55%
Output Enable <sup>Note1</sup> (PIN # 1) Voltage	$V_{IH}$		$\geq 70\% V_{DD}$
Output Disable <sup>Note1</sup> (PIN # 1) Voltage	$V_{IL}$		$\leq 30\% V_{DD}$
Cycle Rise Time	$T_R$	0.016 MHz to 670 MHz 20%~80% $V_{P-P}$	315 pS
Cycle Fall Time	$T_F$	0.016 MHz to 670 MHz 80%~20% $V_{P-P}$	315 pS

<sup>Note1</sup> An optional PIN # 2 as Enable / Disable is available – see Model Selection Guide (page 2)

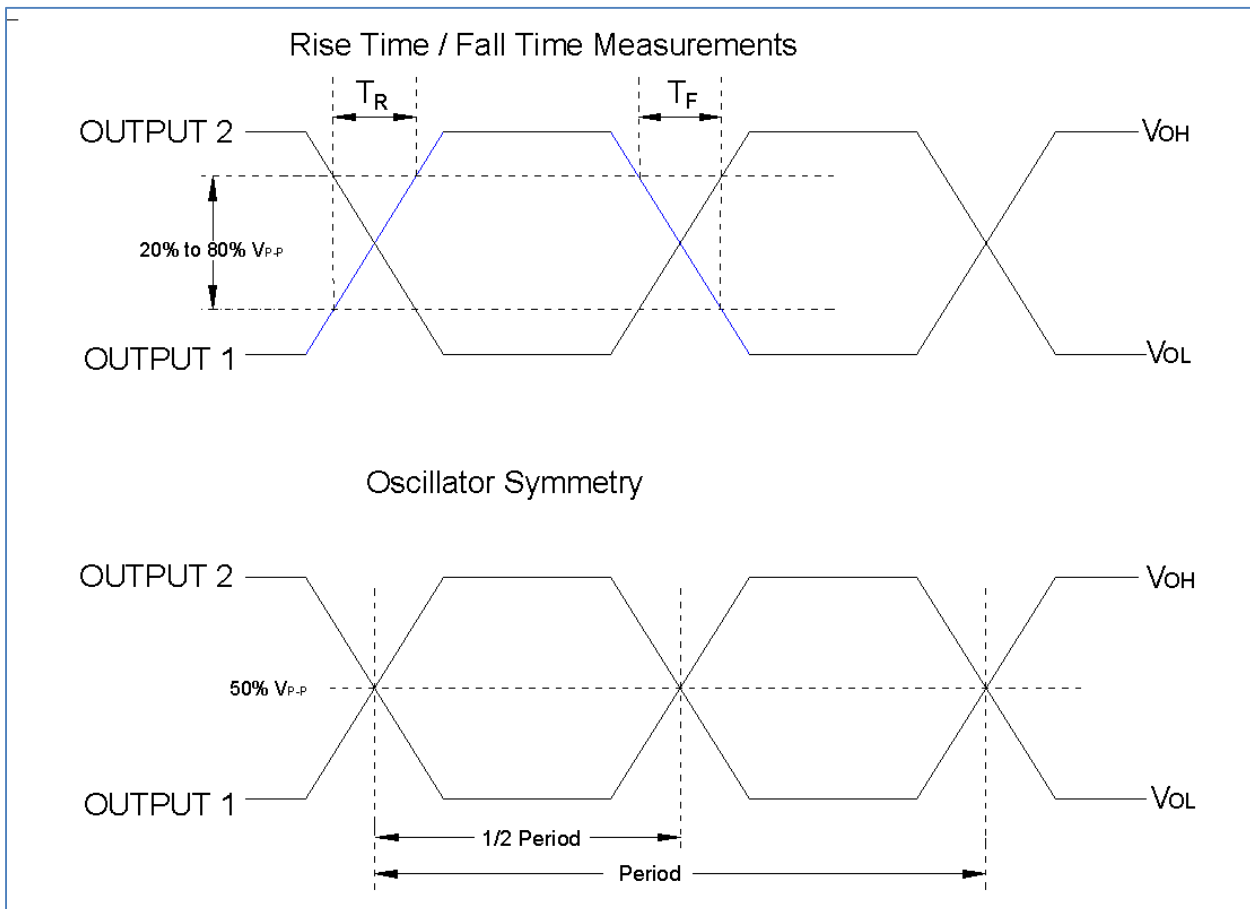

### Phase Noise (typical measurement at 156.25 MHz)

Agilent E5052A Signal Source Analyzer

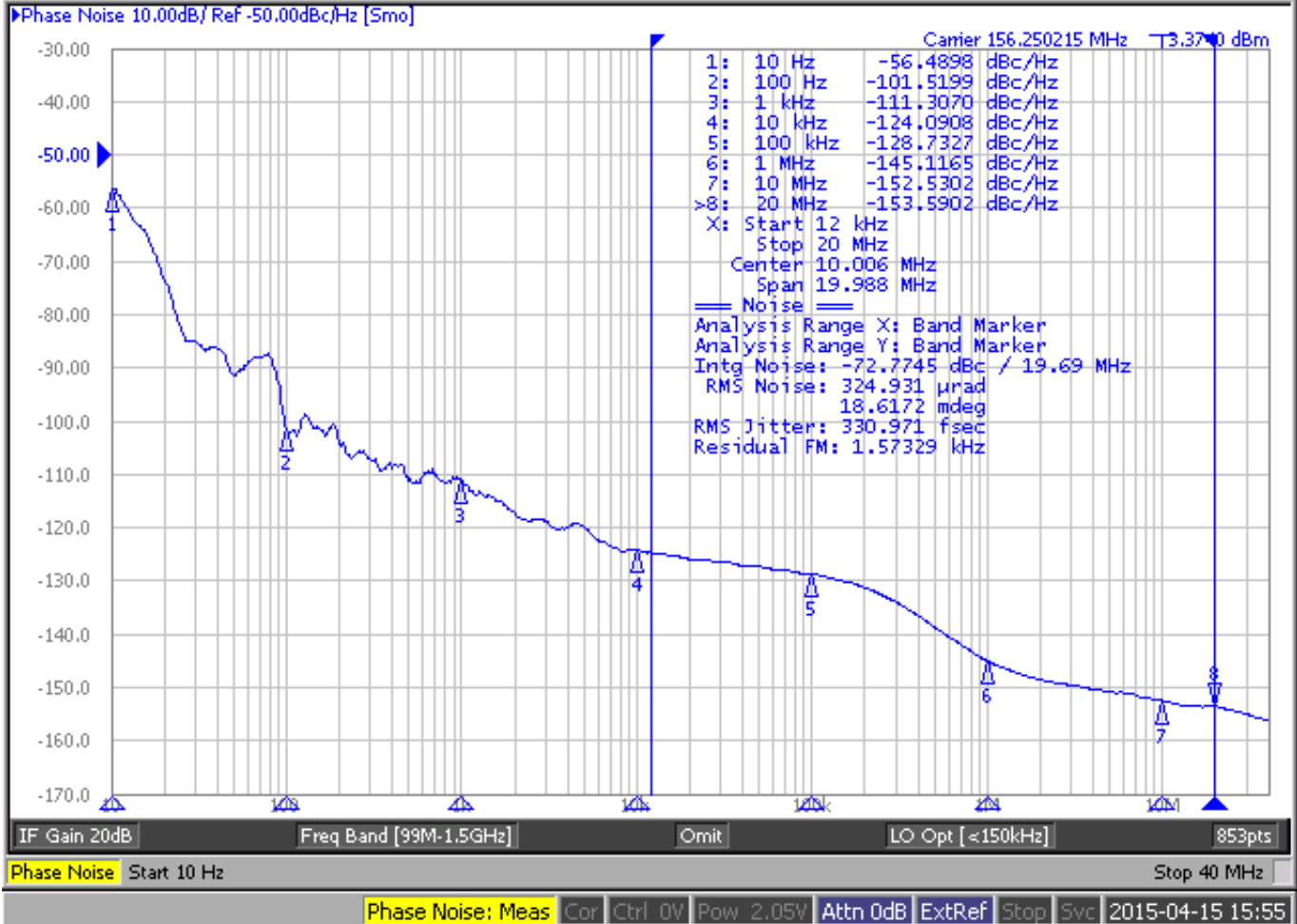

Jitter is frequency dependent. Below are typical measured values for 156.25 MHz.  
 (Consult Fox Tech Support for other frequencies.)

### HCSL Phase Jitter & Time Interval Error (TIE)

Frequency	Phase Jitter (pS) (12kHz to 20MHz)	TIE (pS) (sigma of jitter distribution)
156.25 MHz	0.33	1.5

**Phase Jitter** is integrated from Agilent 5052A Signal Noise Analyzer; measured directly into 50 ohm input;  $V_{DD} = 2.5V$ .

**TIE** was measured on LeCroy LeCroy SDA-6000A Digital Storage Scope, directly into 50 ohm input, with Amherst M1 software;  $V_{DD} = 2.5V$ .

Per **MJSQ spec** (Methodologies for Jitter and Signal Quality specifications)

### LVPECL Random & Deterministic Jitter Composition

Frequency	Random (Rj) (pS RMS)	Deterministic (Dj) (pS P-P)	Total Jitter (Tj) (14 x Rj) + Dj
156.25 MHz	0.7	4.0	15.0

**Rj and Dj**, measured on LeCroy SDA-6000A Digital Storage Scope, directly into 50 ohm input, with Amherst M1 software.

Per **MJSQ spec** (Methodologies for Jitter and Signal Quality specifications)



### Pin Description and Recommended Circuit

Pin #	Name	Type	Function
1	E / D <sup>1</sup>	Logic	Enable / Disable Control of Output (0 = Disabled)
2	NC <sup>2</sup>		No Connection – Leave OPEN
3	GND	Ground	Electrical Ground for V <sub>DD</sub>
4	Output	Output	HCSL Oscillator Output
5	Output 2	Output	Differential HCSL Output
6	V <sub>DD</sub> <sup>3</sup>	Power	Power Supply Source Voltage

#### NOTES:

- <sup>1</sup> Includes pull-up resistor to V<sub>DD</sub> to provide output when the pin (1) is No Connect. (Also see note 2)
- <sup>2</sup> An optional pin # 2 Enable / Disable is available.
- <sup>3</sup> Installation should include a 0.1μF bypass capacitor placed between V<sub>DD</sub> (Pin 6) and GND (Pin 3) to minimize power supply line noise.

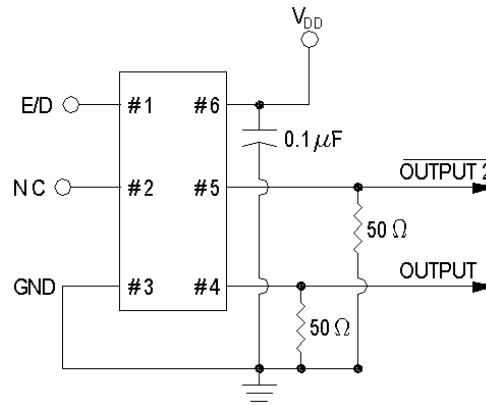
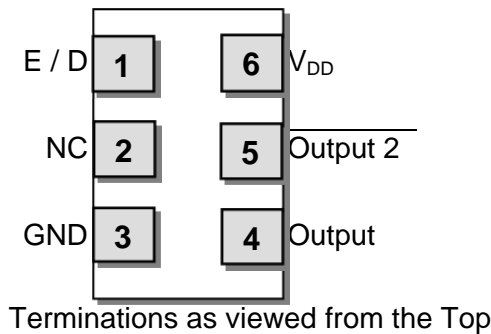

### Enable / Disable Control

Pin # 1 (state)	Output (Pin # 4, Pin # 5)
OPEN (No Connection)	ACTIVE Output
"1" Level $V_{IH} \geq 70\% V_{DD}$	ACTIVE Output
"0" Level $V_{IL} \leq 30\% V_{DD}$	High Impedance

### Soldering Reflow Profile (2 times Maximum at 260°C for 10 seconds MAX)

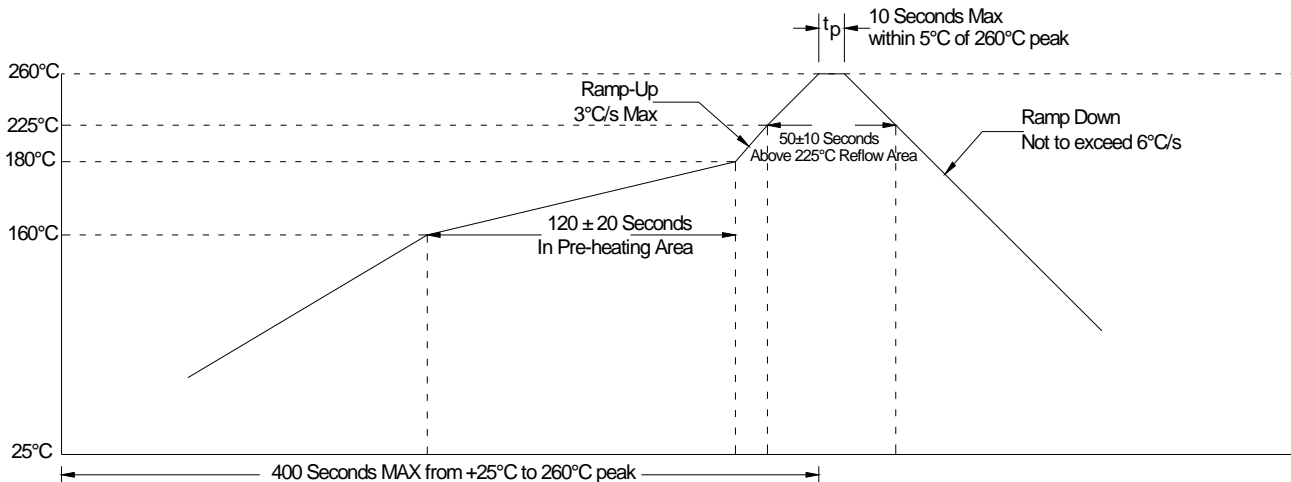

### Mechanical Dimensional Drawing & Pad Layout

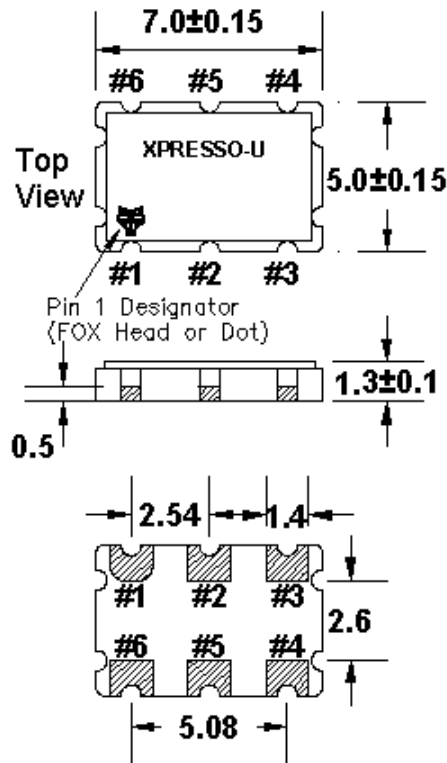

**Actual part marking is depicted.**

See **Traceability** (pg. 9) for more information

### Recommended Solder Pad Layout

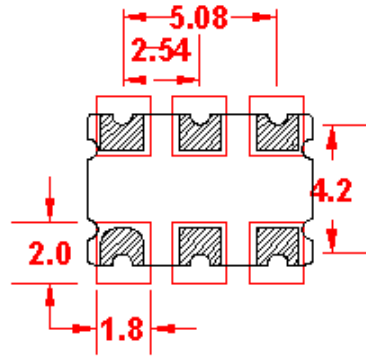

#### Pin Connections

- |          |                     |
|----------|---------------------|
| #1) E/D* | #4) Output          |
| #2) NC*  | #5) Output 2        |
| #3) GND  | #6) V <sub>DD</sub> |

\* An optional PIN # 2 as Enable / Disable is available  
– see Model Selection Guide (page 2)

Drawing is for reference to critical specifications defined by size measurements. Certain non-critical visual attributes, such as side castellations, reference pin shape, etc. may vary

### Tape and Reel Dimensions

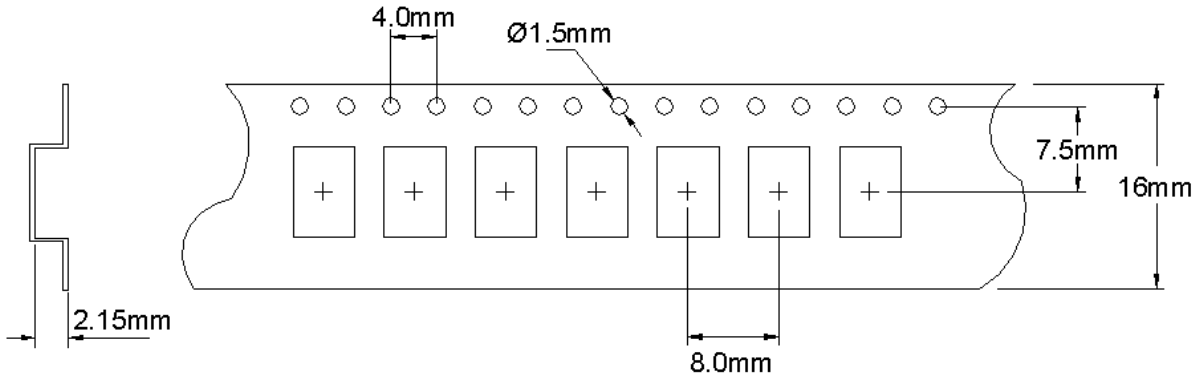

### 1k Reel Dimensions in mm

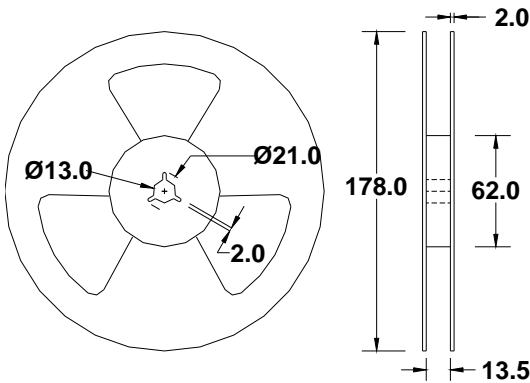

### 2k Reel Dimensions in mm

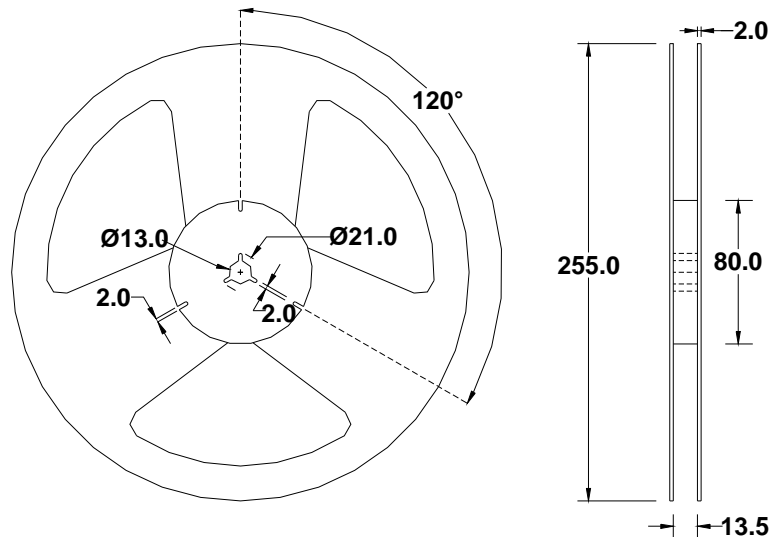

### Labeling (Reels and smaller packaging are labeled with the below)

- Fox Part Number: 867A-156.25-3 →
- Quantity: 2000 pieces →
- Description: FXU-NC725R-156.25 →
- Date Code 1335 →  
(YYWW 2013 35<sup>th</sup> wk)
- LOT # 24435 →

Product label for SKU 867A-156.25-3 showing barcode, quantity (2000), description (FXU-NC725R-156.25), date code (1335), lot (24435), and RoHS compliance information.

## Traceability – LOT Number & Serial Identification

### LOT Number

The LOT Number has direct ties to the customer purchase order. The LOT Number is stored internally in non-volatile memory. XPRESSO-ULTRA parts are packaged in Cut Tape or Tape and Reel and placed in an ESD bag. The package label containing the Lot number is affixed to the ESD bag, and in the case of Tape and Reel it is attached to the reel as well

It is recommended that the XPRESSO-ULTRA parts remain in this ESD bag during storage for protection and identification.

If the parts become separated from the label showing the LOT Number, it can be retrieved from inside one of the parts, and the information that can be obtained is listed below:

- Customer Purchase Order Number
- Internal Fox Sales Order Number
- Dates that the XPRESSO-ULTRA part was shipped from the factory
- The assigned customer part number
- The specification that the part was designed for

---

### Serial Identification

The Serial ID is the individualized information about the configuration of that particular XPRESSO-ULTRA part. The Serial ID is unique for each and every XPRESSO-ULTRA part, and can be read by special Fox equipment.

With the Serial ID, the below information can be obtained about that individual, XPRESSO-ULTRA part:

- Equipment that the XPRESSO-ULTRA part was configured on
- Raw material used to configure the XPRESSO-ULTRA part
- Traceability of the raw material back to the foundries manufacturing lot
- Date and Time that the part was configured
- Any optimized electrical parameters based on customer specifications
- Electrical testing of the actual completed part
- Human resource that was monitoring the configuration of the part

Fox has equipment placed at key Fox locations World Wide to read the Lot Identification and Serial Number of any XPRESSO-ULTRA part produced and can then obtain the information from above within 24 hours

**Mechanical Testing**

<b>Parameter</b>	<b>Test Method</b>
Mechanical Shock	MIL-STD-202 Method 213 Condition C
Mechanical Vibration	MIL-STD-202 Method 204 5g's for 20 minutes 12 cycles of each 3 orientations: X, Y, Z
High Temperature Operating Life (HTOL)	Under Power @ 125°C for 1000 Hours
Hermetic Seal	MIL-STD-202F: Method 112D Test condition C He pressure: 4 ±1 kgf / cm <sup>2</sup> 2 Hour soak



[XpressO-ULTRA Home](#)

[XpressO-ULTRA XOs](#)

[XpressO Brochure](#)

Patent Numbers:  
US 6,664,860, US 5,960,403, US 5,952,890; US 5,960,405; US 6,188,290;  
Foreign Patents: R.S.A. 98/0866, R.O.C. 120851; Singapore 67081, 67082; EP 0958652  
China ZL 98802217.6, Malaysia MY-118540-A, Philippines 1-1998-000245, Hong Kong #HK1026079, Mexico #232179  
US and Foreign Patents Pending  
XpressO® Fox Electronics

#### Contact Information

[\(USA\)-Worldwide Headquarters](#)

Tel: 888-GET-2-FOX

Outside US: +1.239.693.0099,

Fax: +1.239.693.1554

Email: [www.foxonline.com/email.htm](http://www.foxonline.com/email.htm)

[Fox EMEA](#)

Tel: +44.1283.568153

Email: [www.foxonline.com/email.htm](http://www.foxonline.com/email.htm)

[Fox Singapore](#)

Tel: +886-2-22073427,

Email: [www.foxonline.com/email.htm](http://www.foxonline.com/email.htm)

The above specifications, having been carefully prepared and checked, is believed to be accurate at the time of publication; however, no responsibility is assumed by Fox Electronics for inaccuracies.

