

**4N51, 4N52**  
**67023 4N53, 4N54**      HERMETIC , NUMERIC AND HEXADECIMAL  
 DISPLAYS



11/19/03

**Features:**

- Conforms to MIL-PRF-87157
- Three character options  
 Numeric, Hexadecimal or Over range
- 4 X 7 dot matrix character
- Memory latch/decoder/driver is TTL compatible
- Categorized for luminous intensity

**Applications:**

- High reliability systems
- Instrumentation panels
- Communication equipment
- Medical equipment
- Harsh environments

**DESCRIPTION**

The **4N51, 4N52, 4N53 and 4N54** series are solid state numeric and hexadecimal displays for use in high reliability applications. The displays feature an on-board decoder/driver and memory (except 4N53). These displays are hermetically sealed and conform to MIL-PRF-87157, the general specification for light emitting diode displays. The character height is 0.290" (7.37mm).

The 4N51 is a numeric display which decodes positive BCD logic into the numbers "0-9", a "-" sign, a right-hand decimal point, and a test pattern (all LED's on).

The 4N52 is the same as the 4N51, but the decimal point is located on the left side of the device.

The 4N53 is an over range device which displays "±1" and a right-hand decimal point. This display is typically driven using external switching transistors.

The 4N54 is a hexadecimal display which decodes positive BCD logic into 16 characters "0-9, A-F". Input is provided to blank the display (all LED's off) without losing the contents of the memory.

**ABSOLUTE MAXIMUM RATINGS**

Supply Voltage (4N51, 4N52, 4N54) .....	-0.5 V to 7 V
Voltage Applied to Input Logic, DP and Enable Pins .....	-0.5 V to 7 V
Voltage Applied to Blanking Input (4N54 only).....	-0.5 V to 7 V
Forward Current, Each LED (4N53 only).....	10 mA
Reverse Voltage, Each LED (4N53 only) .....	4 V
Storage Temperature .....	-65°C to +125°C
Operating Free-Air Temperature Range.....	-55°C to +100°C
Lead Solder Temperature (10seconds, 1/16" below seating plane).....	260°C

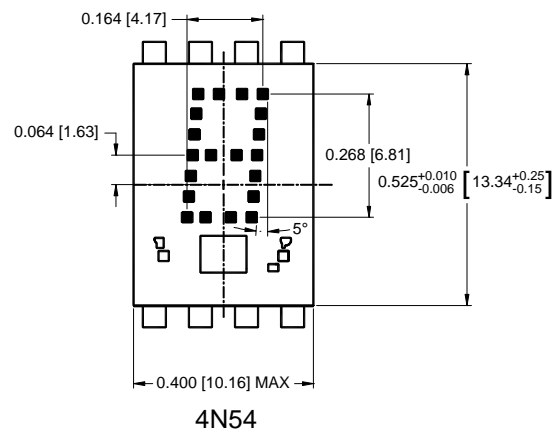
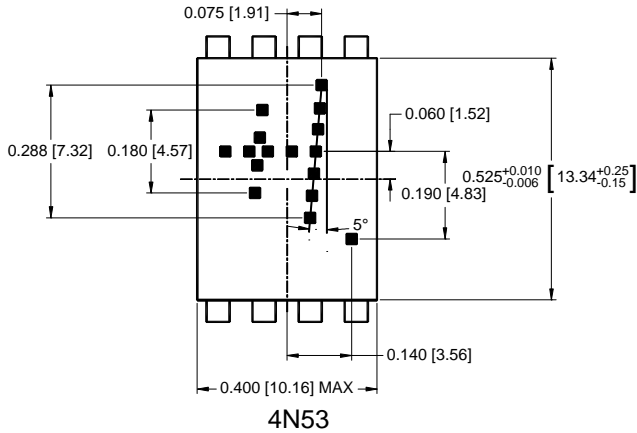
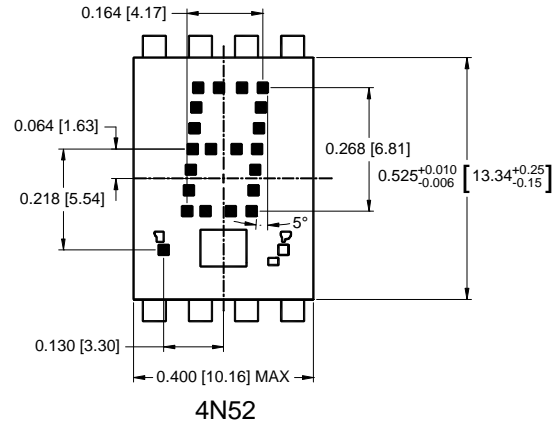
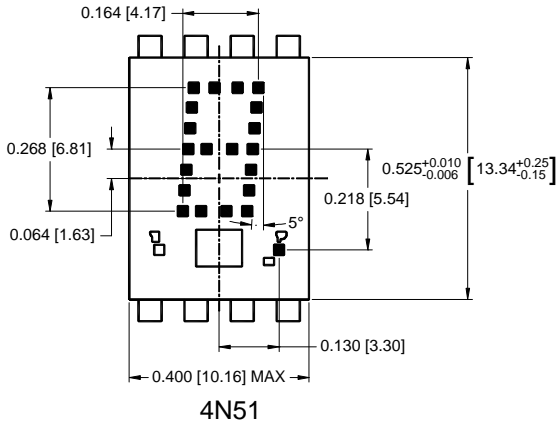

ALL TOLERANCES ARE  $\pm 0.008$  [0.20] UNLESS OTHERWISE SPECIFIED

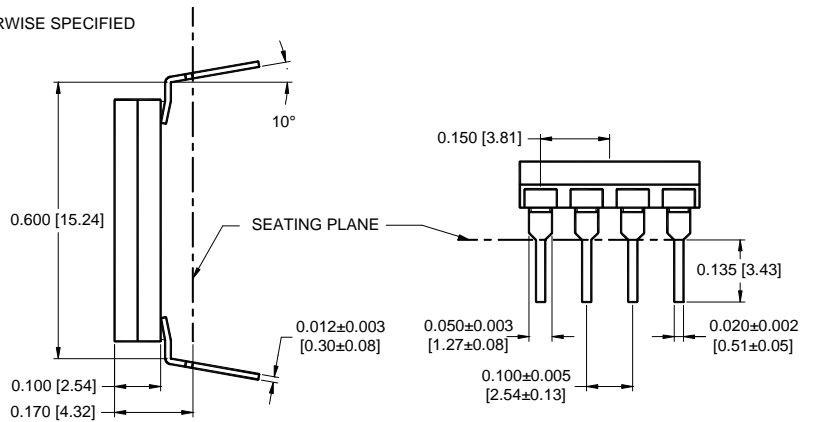
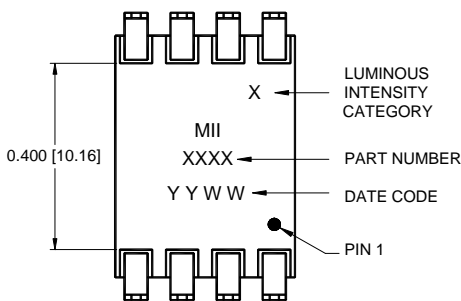

ALL TOLERANCES ARE  $\pm 0.015$  UNLESS OTHERWISE SPECIFIED

ALL DIMENSIONS ARE IN INCHES [MILLIMETERS].

\*JEDEC Registered Data

**4N51, 4N52,  
67023 4N53, 4N54**

**HERMETIC, NUMERIC AND HEXADECIMAL DISPLAYS**

11/19/03

**\*ELECTRICAL OPTICAL CHARACTERISTICS**

T<sub>A</sub> = -55°C to +100°C unless otherwise specified.

PARAMETER	SYMBOL	MIN	TYP	MAX	UNITS	TEST CONDITIONS	NOTE
Supply Current	4N51 4N52 4N54	I <sub>CC</sub>		112 112 112	170 170 170	mA V <sub>CC</sub> = 5.5V Numeral 5 and DP lighted	1
Power Dissipation	4N51 4N52 4N53 4N54	P <sub>T</sub>		560 560 280 560	935 935 320 935	mW V <sub>CC</sub> = 5.5V Numeral 5 and DP lighted	1, 3
Luminous Intensity per LED	4N51 4N52 4N53 4N54	I <sub>V</sub>	40 40 45 40	85 85 85 85		μcd V <sub>CC</sub> = 5V, T <sub>A</sub> = 25°C V <sub>CC</sub> = 5V, T <sub>A</sub> = 25°C I <sub>F</sub> = 10mA, T <sub>A</sub> = 25°C V <sub>CC</sub> = 5V, T <sub>A</sub> = 25°C	2
Forward Voltage per LED	4N53	V <sub>F</sub>		1.6	2.0	V I <sub>F</sub> = 10mA	
Logic Low-Level Input Voltage	4N51 4N52 4N54	V <sub>IL</sub>			0.8 0.8 0.8	V V <sub>CC</sub> = 4.5V	
Logic High-Level Input Voltage	4N51 4N52 4N54	V <sub>IH</sub>	2 2 2			V V <sub>CC</sub> = 4.5V	
Enable Low-Voltage; Data Being Entered	4N51 4N52 4N54	V <sub>EL</sub>			0.8 0.8 0.8	V V <sub>CC</sub> = 4.5V	
Enable High-Voltage; data not being entered	4N51 4N52 4N54	V <sub>EH</sub>	2 2 2			V V <sub>CC</sub> = 4.5V	
Blanking Low-Voltage display not blanked	4N54	V <sub>BL</sub>			0.8	V V <sub>CC</sub> = 4.5V	
Blanking High-Voltage display not blanked	4N54	V <sub>BH</sub>	3.5			V V <sub>CC</sub> = 4.5V	
Leak Rate	ALL				5x10 <sup>-8</sup>	cc/sec	
Blanking Low-Level Input Current	4N54	I <sub>BL</sub>			50	mA V <sub>CC</sub> = 5.5V, V <sub>BL</sub> = 0.8V	
Blanking High-Level Input Current	4N54	I <sub>BH</sub>			1.0	mA V <sub>CC</sub> = 5.5V, V <sub>BH</sub> = 4.5V	
Logic Low-Level Input Current	4N51 4N52 4N54	I <sub>IL</sub>			-1.6	mA V <sub>CC</sub> = 5.5V, V <sub>IL</sub> = 0.4V	
Logic High-Level Input Current	4N51 4N52 4N54	I <sub>IH</sub>			+100	μA V <sub>CC</sub> = 5.5V, V <sub>IH</sub> = 2.4V	
Enable Low-Level Input Current	4N51 4N52 4N54	I <sub>EL</sub>			-1.6	mA V <sub>CC</sub> = 5.5V, V <sub>EL</sub> = 0.4V	
Enable High-Level Input Current	4N51 4N52 4N54	I <sub>EH</sub>			+130	μA V <sub>CC</sub> = 5.5V, V <sub>EH</sub> = 2.4V	
Wavelength at Peak Emission	ALL	λ <sub>P</sub>		655		nm T <sub>A</sub> = 25°C	
Dominant Wavelength	ALL	d		640		nm T <sub>A</sub> = 25°C	2
Forward Voltage per LED	4N53	V <sub>F</sub>		1.6	2.0	V I <sub>F</sub> = 10mA	
Weight	ALL			1		gm	

**NOTES:**

1. All typical values at V<sub>CC</sub> = 5.0 volts, t<sub>A</sub> = 25°C.
2. The dominant wavelength, λ<sub>d</sub> is a single wavelength that defines the saturated color of monochromatic light, as derived from the CIE chromaticity diagram.
3. For 4N53 test conditions, I<sub>F</sub> = 10mA, all diodes lit.

\*JEDEC Registered Data

**4N51, 4N52, 4N54 Logic**

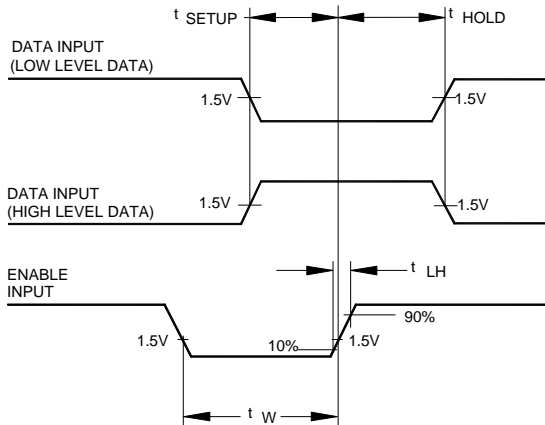

FIGURE 1. Timing Diagram of 4N51, 4N52 and 4N54 Series Logic

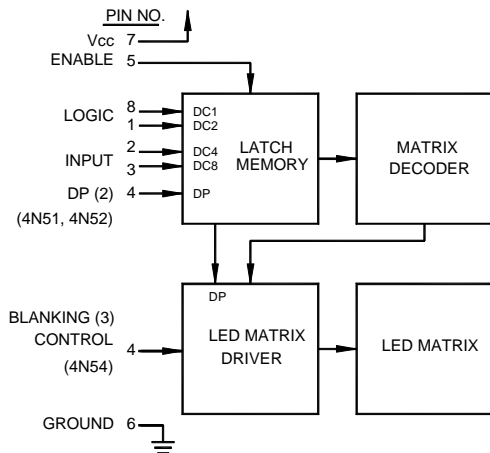

FIGURE 2. Block Diagram of 4N51, 4N52 and 4N54 Series Logic

TRUTH TABLE						
BCD DATA <sup>(1)</sup>				4N51/4N52	4N54	
X <sub>8</sub>	X <sub>4</sub>	X <sub>2</sub>	X <sub>1</sub>			
L	L	L	L	0	0	
L	L	L	H	1	1	
L	L	H	L	2	2	
L	L	H	H	3	3	
L	H	L	L	4	4	
L	H	L	H	5	5	
L	H	H	L	6	6	
L	H	H	H	7	7	
H	L	L	L	8	8	
H	L	L	H	9	9	
H	L	H	L	⏏	A	
H	L	H	H	(BLANK)	B	
H	H	L	L	(BLANK)	C	
H	H	L	H	.....	D	
H	H	H	L	(BLANK)	E	
H	H	H	H	(BLANK)	F	
DECIMAL PT. <sup>(2)</sup>				ON	V <sub>DP</sub> = L	
				OFF	V <sub>DP</sub> = H	
ENABLE <sup>(1)</sup>				LOAD DATA	V <sub>E</sub> = L	
				LATCH DATA	V <sub>E</sub> = H	
BLANKING <sup>(3)</sup>				DISPLAY ON	V <sub>B</sub> = L	
				DISPLAY OFF	V <sub>B</sub> = H	

**NOTES:**

1. H = Logic High; L = Logic Low. With the enable input at logic high changes in BCD input levels or D.P. input have no effect upon display memory, displayed character, or D.P.
2. The decimal point, DP, pertains only to the 4N51 and 4N52 displays.
3. The blanking control, B, pertains only to the 4N54 hexadecimal display. Blanking input has no effect upon memory.

**4N53 Over Range Character**

PIN	FUNCTION
1	Plus
2	Numeral One
3	Numeral One
4	DP
5	Open
6	Open
7	Vcc
8	Minus/Plus

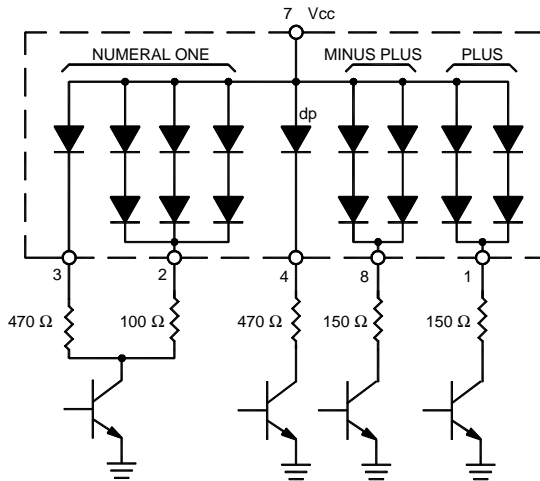

FIGURE 3. Typical Driving Circuit

**TRUTH TABLE FOR TYPICAL DRIVING CIRCUIT**

CHARACTER	PIN			
	1	2,3	4	8
+	H	X	X	H
-	L	X	X	H
1	X	H	X	X
DECIMAL POINT	X	X	H	X
BLANK	L	L	L	L

**NOTES:**

- L: Line switching transistor in figure 3 cutoff.
- H: Line transistor in figure 3 saturated.
- X: Don't Care.

**\*RECOMMENDED OPERATING CONDITIONS:**

PARAMETER		SYMBOL	MIN	MAX	UNITS
Supply Voltage	4N51	V <sub>CC</sub>	4.5	5.5	V
	4N52		4.5	5.5	V
	4N53		NA	NA	NA
	4N54		4.5	5.5	V
Operating Temperature	ALL	T <sub>A</sub>	-55	100	°C
Enable Pulse Width	4N51	t <sub>W</sub>	100		Ns
	4N52				
	4N54				
Time data must be held before positive transition of enable line	4N51	t <sub>SETUP</sub>	50		ns
	4N52				
	4N54				
Time data must be held after positive transition of enable line	4N51	t <sub>HOLD</sub>	50		ns
	4N52				
	4N54				
Enable pulse rise time	4N51	t <sub>TLH</sub>		200	ns
	4N52				
	4N54				
Forward Current	4N53	I <sub>F</sub>	5	10	mA

**SELECTION GUIDE**

67023-001	4N51 Commercial
67023-011	4N51 Military Temp. Range
67023-101	4N51 Screened, TXV level
67023-101C	4N51 DSCC P/N JM87157/00101AXX
67023-002	4N52 Commercial
67023-012	4N52 Military Temp. Range
67023-102	4N52 Screened, TXV level
67023-102C	4N52 DSCC P/N JM87157/00102AXX
67023-003	4N53 Commercial
67023-013	4N53 Military Temp. Range
67023-103	4N53 Screened, TXV level
67023-103C	4N53 DSCC P/N JM87157/00103AXX
67023-004	4N54 Commercial
67023-014	4N54 Military Temp. Range
67023-104	4N54 Screened, TXV level
67023-104C	4N54 DSCC P/N JM87157/00104AXX

**NOTES:**

1. When ordering DSCC part numbers, you may order by the MII part number or the DSCC part number.
2. The first X at the end of M87157/0010XA[X]X designates lead finish. In place of the X use A for hot solder dip or C for gold finish.
3. Second X at the end of the M87157/0010XA[X]X designates luminous intensity code. In place of the X use C thru K to indicate desired intensity level.

\*JEDEC Registered Data