

2698B Enhanced Octal Universal Asynchronous Receiver/Transmitter (Octal UART)

Military Communications and
Industrial Products

Product Specification

DESCRIPTION

The Signetics 2698B Enhanced Octal Universal Asynchronous Receiver/Transmitter (Octal UART) is a single chip MOS-LSI communications device that provides eight full-duplex asynchronous receiver/transmitter channels in a single package. It is fabricated with Signetics CMOS technology which combines the benefits of high density and low power consumption.

The operating speed of each receiver and transmitter can be selected independently as one of eighteen fixed baud rates, a 16X clock derived from a programmable counter/timer, or an external 1X or 16X clock. The baud rate generator and counter/timer can operate directly from a crystal or from external clock inputs. The ability to independently program the operating speed of the receiver and transmitter make the Octal UART particularly attractive for dual-speed channel applications such as clustered terminal systems.

The receiver is quadruple buffered to minimize the potential of receiver overrun or to reduce interrupt overhead in interrupt driven systems. In addition, a handshaking capability is provided to disable a remote UART transmitter when the receiver buffer is full.

The UART provides a power-down mode in which the oscillator is frozen but the register contents are stored. This results in reduced power consumption on the order of several magnitudes. The Octal UART is fully TTL compatible and operates from a single +5V power supply.

The 2698B is an upwardly compatible version of the 2698A Octal UART. In LDCC packaging, it is enhanced by the addition of receiver ready or FIFO full status outputs, and transmitter empty status outputs for each channel on 16 multipurpose I/O pins. The multipurpose I/O pins of the 2698B were inputs only on the 2698A.

FEATURES

- Eight full-duplex asynchronous receiver/transmitters
- Quadruple buffered receiver data register
- Programmable data format:
 - 5 to 8 data bits plus parity
 - Odd, even, no parity or force parity
 - 1, 1.5 or 2 stop bits programmable in 1/16-bit increments
- Baud rate for the receiver and transmitter selectable from:
 - 18 fixed rates: 50 to 38.4K baud
 - User-defined rates from the programmable counter/timer associated with each of four blocks
 - External 1x or 16x clock
- Parity, framing, and overrun error detection
- False start bit detection
- Line break detection and generation
- Programmable channel mode
 - Normal (full-duplex), automatic echo, local loop back, remote loopback
- Four multi-function programmable 16-bit counter/timers
- Four interrupt outputs with eight maskable interrupting conditions for each output
- Receiver ready/FIFO full and transmitter ready status available on 16 multi-function pins in LLCC package
- On-chip crystal oscillator
- TTL compatible
- Single +5V power supply with low power mode

PIN CONFIGURATIONS

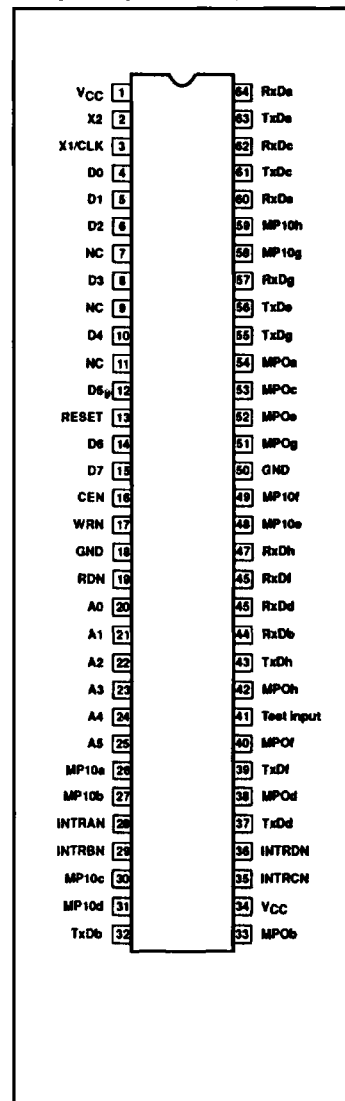

Enhanced Octal Universal Asynchronous Receiver/Transmitter

2698B

ORDERING INFORMATION

DESCRIPTION	ORDERING CODE
84-Pin LLCC	2698B/BYA
64-Pin Ceramic DIP	2698B/BXA
84-Pin Ceramic PGA	2698B/BZA

PIN CONFIGURATION LLCC

TOP VIEW

Pin	Function	Pin	Function
1	TxDa	43	MPOb
2	MPP2g	44	MPP1d
3	RxDa	45	VCC
4	MPP2h	46	INTRCN
5	VCC	47	INTRDN
6	X2	48	MPP2c
7	X1/CLK	49	TxDd
8	D0	50	MPP2d
9	D1	51	MPOd
10	D2	52	TxDf
11	D3	53	MPOf
12	D4	54	MPOh
13	D5	55	TxDh
14	MPI1a	56	RxDb
15	RESET	57	RxDd
16	D6	58	RxDf
17	D7	59	RxDh
18	CEN	60	MPI1e
19	WRN	61	MPI0e
20	GND	62	MPI1f
21	MPI1b	63	MPI0f
22	RDN	64	MPP1e
23	A0	65	GND
24	MPP1a	66	MPP1f
25	A1	67	MPOg
26	MPP1b	68	MPP2e
27	A2	69	MPOe
28	MPP2a	70	MPP2f
29	A3	71	MPOc
30	MPP2b	72	MPOa
31	A4	73	TxDg
32	A5	74	TxDd
33	MPI0a	75	RxDg
34	MPI0b	76	MPI0g
35	INTRAN	77	MPI0h
36	INTRBN	78	MPI1g
37	MPI0c	79	RxDe
38	MPI1c	80	MPI1h
39	MPI0d	81	TxDc
40	MPI1d	82	MPP1g
41	TxDb	83	RxDc
42	MPP1c	84	MPP1h

PIN CONFIGURATION PGA

Pin No.	Function	Pin No.	Function	Pin No.	Function
C3	D4	J5	MPI1d	C10	MPI3e
C2	D5	H5	TxDc	D8	MPOe
B1	MPI1a	K5	MPI2c	B10	MPI3f
C1	RESET	K6	MPOb	D8	MPOc
D3	D6	J6	MPI2d	A10	MPOa
D2	D7	H6	VCC	C9	TxDg
D1	CEN	K7	INTR2N	B9	TxDc
E2	WRN	K8	INTR3N	C8	RxDg
E3	GND	J7	MPI3c	B8	MPI0g
E1	MPI1b	K9	TxDd	A9	MPI0h
F1	RDN	H7	MPI3d	A8	MPI1g
F2	AC	K10	MPOd	C7	RxD3
F3	MPI2a	J8	TxDf	B7	MPI1h
G1	A1	J9	MPOf	A7	TxDc
H1	MPI2b	H8	MPOh	B6	MPI2g
G2	A2	H9	TxDh	C8	RxDc
J1	MPI3a	J10	RxDb	A8	MPI2h
G3	A3	H10	RxDd	A5	TxDa
H2	MPI13b	G8	RxDf	B5	MPI13g
H4	A4	G9	RxDh	C5	RxDa
J2	A5	G10	MPI1e	A4	MPI13h
H3	MPI0a	F9	MPI0e	A3	VCC
J3	MPI0b	F8	MPI1f	B4	X2
K2	INTR0N	F10	MPI0f	A2	X1/CLK
K9	INTR1N	E10	MPI2e	C4	D0
H4	MPI0c	E9	GND	A1	D1
J4	MPI1c	E8	MPI2f	B3	D2
K4	MPI0d	D10	MPOg	B2	D3

Enhanced Octal Universal Asynchronous Receiver/Transmitter

2698B

BLOCK DIAGRAM

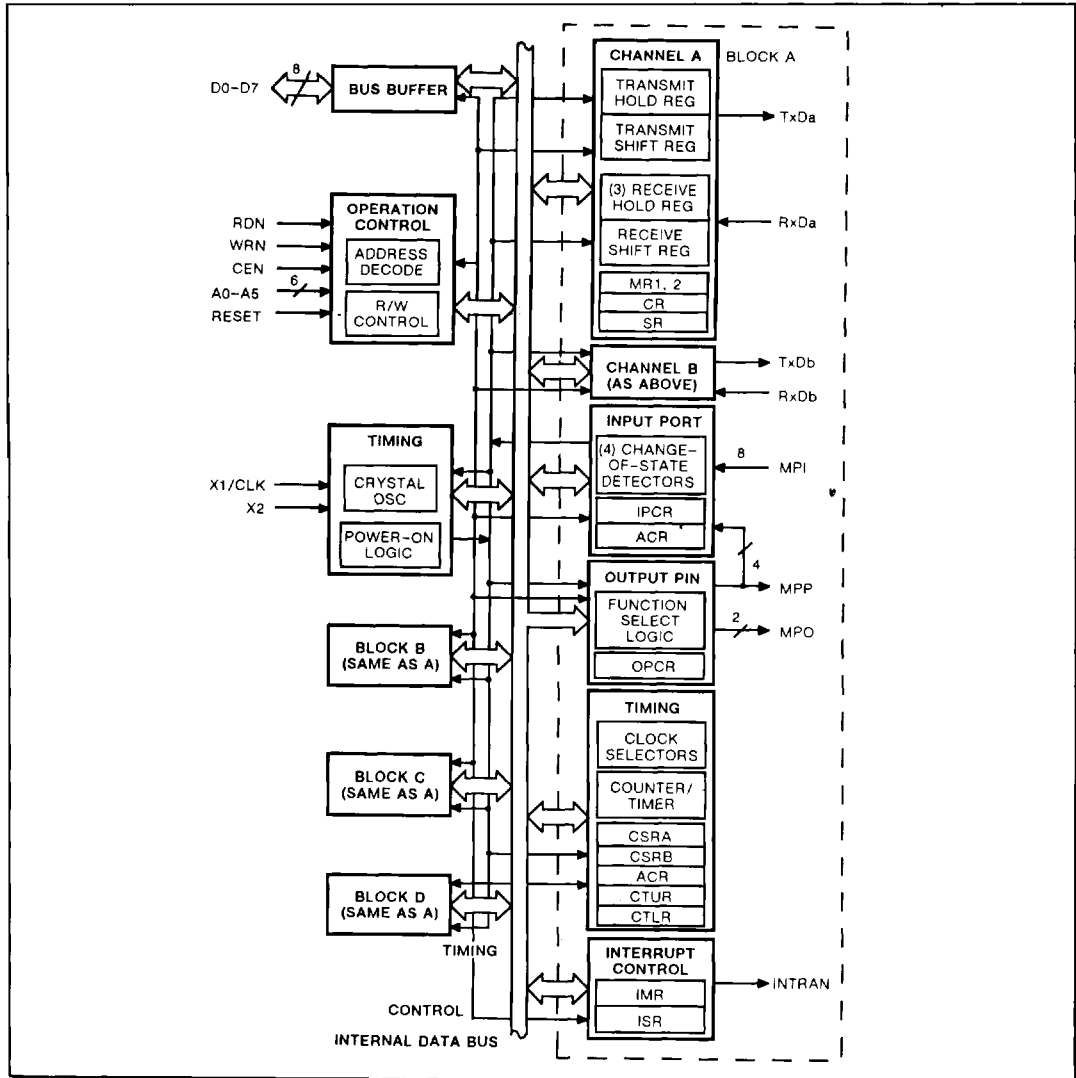

Enhanced Octal Universal Asynchronous Receiver/Transmitter

2698B

PIN DESCRIPTION

MNEMONIC	PIN NO.		TYPE	NAME AND FUNCTION
	DIP	LDCC		
D0–D7	4–6, 8, 10, 12, 14, 15	8–13, 16, 17	I/O	Data Bus: Active—High 8-bit bidirectional 3-state data bus. Bit 0 is the LSB and bit 7 is the MSB. All data, command, and status transfers between the CPU and the Octal UART take place over this bus. The direction of the transfer is controlled by the WRN and RDN inputs when the CEN input is low. When the CEN input is High, the data bus is in the 3-state condition.
CEN	16	18	I	Chip Enable: Active-Low input. When Low, data transfers between the CPU and the Octal UART are enabled on D0–D7 as controlled by the WRN, RDN and A0–A5 inputs. When CEN is High, the Octal UART is effectively isolated from the data bus and D0–D7 are placed in the 3-state condition.
WRN	17	19	I	Write Strobe: Active-Low input. A Low on this pin while CEN is Low causes the contents of the data bus to be transferred to the register selected by A0–A5. The transfer occurs on the trailing (rising) edge of the signal.
RDN	19	22	I	Read Strobe: Active-Low input. A Low on this pin while CEN is Low causes the contents of the register selected by A0–A5 to be placed on the data bus. The read cycle begins on the leading (falling) edge of RDN.
A0–A5	20–25	23, 25, 27, 29, 31, 32	I	Address Inputs: Active-High address inputs to select the Octal UART registers for read/write operations.
RESET	13	15	I	Reset: Master reset. A High on this pin clears the status register (SR), clears the interrupt mask register (IMR), clears the interrupt status register (ISR), clears the output port configuration register (OPCR), places the receiver and transmitter in the inactive state causing the TxD output to go to the marking (High) state, and stops the counter/timer.
INTRAN– INTRDN	28, 29, 35, 36	35, 36, 46, 47	O	Interrupt Request: This active-Low open drain output is asserted on occurrence of one or more of eight maskable interrupting conditions. The CPU can read the interrupt status register to determine the interrupting condition(s).
X1/CLK	3	7	I	Crystal 1: Crystal or external clock input. When using the crystal oscillator, this pin serves as the connection for one side of the crystal. If a crystal is not used, an external clock is supplied at this input. An external clock (or crystal) is required even if the internal baud rate generator is not utilized. This clock is used to drive the internal baud rate generator, as an optional input to the timer/counter, and to provide other clocking signals required by the chip.
X2	2	6	I	Crystal 2: Connection for other side of crystal. If an external source is used instead of a crystal, this connection should be left open (see Figure 7).
RxDa–RxDh	64, 44, 62, 45, 60, 46, 57, 47	3, 56, 83, 57, 79, 58, 75, 59	I	Receiver Serial Data Input: The least significant bit is received first. If external receiver clock is specified, this input is sampled on the rising edge of the clock.
TxDa–TxDh	63, 32, 61, 37, 56, 39, 55, 43	1, 41, 81, 49, 74, 52, 73, 55	O	Transmitter Serial Data Output: The least significant bit is transmitted first. This output is held in the marking (High) condition when the transmitter is idle or disabled and when the Octal UART is operating in local loopback mode. If external transmitter is specified, the data is shifted on the falling edge of the transmitter clock.
MPOa–MPOh	54, 33, 53, 38, 52, 40, 51, 42	72, 43, 71, 51, 69, 53, 67, 54	O	Multi-Purpose Output: One of the following functions can be selected for this output pin by programming the auxiliary control register: RTSN – Request to send active-Low output. This output is asserted and negated via the command register. By appropriate programming of the mode registers, RTSN can be programmed to be automatically reset after the character in the transmitter is completely shifted or when the receiver FIFO and shift register are full. C/TO – The counter/timer output. TxC1X – The 1X clock for the transmitter. TxC16X – The 16X clock for the transmitter. RxC1X – The 1X clock for the receiver. RxC16X – The 16X clock for the receiver. TxRDY – Transmitter holding register empty signal. RxRDY/FFULL – Receiver FIFO not empty/full signal.
MPI0a–MPI0h	26, 27, 30, 31, 48, 49, 58, 59	33, 34, 37, 39, 61, 63, 76, 77	I	Multi-Purpose Input 0: This pin can be programmed to serve as an input for one of the following functions: GPI – General purpose input. The current state of the pin can be determined by reading the IPCR or input port register. CTS – Clear-to-send active-Low input.

Enhanced Octal Universal Asynchronous Receiver/Transmitter

2698B

PIN DESCRIPTION (Continued)

MNEMONIC	PIN NO.		TYPE	NAME AND FUNCTION
	DIP	LDCC		
MPI1a-MPI1h	NC	14, 21, 38, 40, 60, 62, 78, 80	I	Multi-Purpose Input 1: This pin can be programmed to serve as an input for one of the following functions: GPI - General purpose input. The current state of the pin can be determined by reading the IPCR or input port register. CTCLK - Counter/timer external clock input. Only channels a, c, e, and g change to C/T inputs; channels b, d, f, and h stay GPI.
MPP1a-MPP1h	NC	24, 26, 42, 44, 64, 66, 82, 84	I/O	Multi-Purpose Pin 1: This pin can be programmed to serve as an input or output for the following functions: GPI - General purpose input: This is the default condition for this pin. The current state of the pin can be determined by reading the input port register. TCLK : Transmitter external clock input. This may be a 1X or 16X clock as programmed by CSR[3:0]. TxRDY : Active-Low open drain output. Transmitter holding register empty signal. This function is selected for this pin by programming OPCR[7] - 1.
MPP2a-MPP2h	NC	28, 30, 48, 50, 68, 70, 2, 4	I/O	Multi-Purpose Pin 2: This pin can be programmed to serve as an input or output for the following functions: GPI : General purpose input. This is the default condition for this pin. The current state of the pin can be determined by reading the input port register. RCLK : Receiver external clock input. This may be a 1X or 16X clock as programmed by CSR[7:4]. RxRDY.FFULL : Active-Low open drain output. Receiver FIFO not empty/full signal. This function is selected for this pin by programming OPCR[7] - 1.
Test Input	41	-	I	Test Input: This pin is used as an input for test purposes at the factory while in test mode. This pin can be treated as 'N/C' by the user. It can be tied high, tied low, or left open.
V _{CC}	1, 34	5, 45	I	Power Supply: +5V supply input.
GND	18, 50	20, 65	I	Ground

BLOCK DIAGRAM

As shown in the block diagram, the Octal UART consists of: data bus buffer, interrupt control, operation control, timing, and eight receiver and transmitter channels. The eight channels are divided into four different blocks, each block independent of each other (see Figure 1).

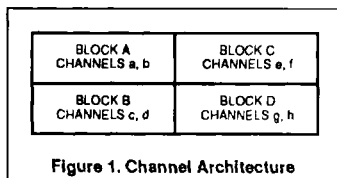

Channel Blocks

There are four blocks (Figure 1), each containing two sets of receiver/transmitters. In the following discussion, the description applies to Block A which contains channels a and b. However, the same information applies to all channel blocks.

Data Bus Buffer

The data bus buffer provides the interface between the external and internal data buses. It is controlled by the operation control block to allow read and write operations to take place between the controlling CPU and the Octal UART.

Interrupt Control

A single interrupt output per block (INTRN) is provided which is asserted on occurrence of any of the following internal events:

- Transmit holding register ready for each channel
- Receive holding register ready or FIFO full for each channel
- Change in break received status for each channel
- Counter reached terminal count
- Change in MPI input

Associated with the interrupt system are the interrupt mask register (IMR) and the interrupt status register (ISR). The IMR can be programmed to select only certain conditions, of the above, to cause INTRN to be asserted. The ISR can be read by the CPU to determine all currently active interrupting conditions. However, the bits of the ISR are not masked by the IMR. The transmitter ready status and the receiver ready or FIFO full status can be provided on MPP1a, MPP1b, MPP2a, and MPP2b by setting OPCR[7]. these outputs are not masked by IMR.

Operation Control

The operation control logic receives operation commands from the CPU and generates appropriate signals to internal sections to control device operation. It contains address decoding and read and write circuits to permit communi-

cations with the microprocessor via the data bus buffer. The functions performed by the CPU read and write operations are shown in Table 1.

Mode registers 1 and 2 are accessed via an auxiliary pointer. The pointer is set to MR1 by RESET or by issuing a reset pointer command via the command register. Any read or write of the mode register while the pointer is at MR1 switches the pointer to MR2. The pointer then remains at MR2 so that subsequent accesses are to MR2, unless the pointer is reset to MR1 as already described.

Timing Circuits

The timing block consists of a crystal oscillator, a baud rate generator, a programmable 16-bit counter/timer for each block, and two clock selectors.

The crystal oscillator operates directly from a 3.6864MHz crystal connected across the X1/CLK and X2 inputs with a minimum of external components. If an external clock of the appropriate frequency is available, it may be connected to X1/CLK. If an external clock is used instead of a crystal, X1 must be driven and X2 left floating as shown in Figure 7. The clock serves as the basic timing reference for the baud rate generator (BRG), the counter/timer, and other internal circuits. A clock frequency, within the limits specified in the electrical specifications, must be supplied even if the internal BRG is not used.

Enhanced Octal Universal Asynchronous Receiver/Transmitter

2698B

Table 1. Register Addressing

A5	A4	A3	A2	A1	A0	READ (RDN=0)	WRITE (WRN=0)	A5	A4	A3	A2	A1	A0	READ (RDN=0)	WRITE (WRN=0)
0	0	0	0	0	0	MR1a, MR2a	MR1a, MR2a	1	0	0	0	0	0	MR1e, MR2e	MR1e, MR2e
0	0	0	0	0	1	SRa	CSRa	1	0	0	0	0	1	SRe	CSRe
0	0	0	0	1	0	Reserved*	CRa	1	0	0	0	1	0	Reserved*	CRe
0	0	0	0	1	1	RHRa	THRa	1	0	0	0	1	1	RHRe	THRe
0	0	0	1	0	0	IPCRA	ACRA	1	0	0	1	0	0	IPCRC	ACRC
0	0	0	1	0	1	ISRA	IMRA	1	0	0	1	0	1	ISRC	IMRC
0	0	0	1	1	0	CTUA	CTURA	1	0	0	1	1	0	CTUC	CTURC
0	0	0	1	1	1	CTLA	CTLRA	1	0	0	1	1	1	CTLC	CTLRC
0	0	1	0	0	0	MR1b, MR2b	MR1b, MR2b	1	0	1	0	0	0	MR1f, MR2f	MR1f, MR2f
0	0	1	0	0	1	SRb	CSRb	1	0	1	0	0	1	SRf	CSRf
0	0	1	0	1	0	Reserved*	CRb	1	0	1	0	1	0	Reserved*	CRf
0	0	1	0	1	1	RHRb	THRb	1	0	1	0	1	1	RHRf	THRf
0	0	1	1	0	0	Reserved*	Reserved*	1	0	1	1	0	0	Reserved*	Reserved*
0	0	1	1	0	1	Input port A	OPCRA	1	0	1	1	0	1	Input port C	OPCRC
0	0	1	1	1	0	Start C/T A	Reserved*	1	0	1	1	1	0	Start C/T C	Reserved*
0	0	1	1	1	1	Stop C/T A	Reserved*	1	0	1	1	1	1	Stop C/T C	Reserved*
0	1	0	0	0	0	MR1c, MR2c	MR1c, MR2c	1	1	0	0	0	0	MR1g, MR2g	MR1g, MR2g
0	1	0	0	0	1	SRc	CSRc	1	1	0	0	0	1	SRg	CSRg
0	1	0	0	1	0	Reserved*	CRc	1	1	0	0	1	0	Reserved*	CRg
0	1	0	0	1	1	RHRc	THRc	1	1	0	0	1	1	RHRg	THRg
0	1	0	1	0	0	IPCRB	ACRB	1	1	0	1	0	0	IPCRC	ACRC
0	1	0	1	0	1	ISRB	IMRB	1	1	0	1	0	1	ISRC	IMRC
0	1	0	1	1	0	CTUB	CTURB	1	1	0	1	1	0	CTUD	CTURD
0	1	0	1	1	1	CTLB	CTLRB	1	1	0	1	1	1	CTLD	CTLRD
0	1	1	0	0	0	MR1d, MR2d	MR1d, MR2d	1	1	1	0	0	0	MR1h, MR2h	MR1h, MR2h
0	1	1	0	0	1	SRd	CSRd	1	1	1	0	0	1	SRh	CSRh
0	1	1	0	1	0	Reserved*	CRd	1	1	1	0	1	0	Reserved*	CRh
0	1	1	0	1	1	RHRd	THRd	1	1	1	0	1	1	RHRh	THRh
0	1	1	1	0	0	Reserved*	Reserved*	1	1	1	1	0	0	Reserved*	Reserved*
0	1	1	1	0	1	Input port B	OPCRB	1	1	1	1	0	1	Input port D	OPCRD
0	1	1	1	1	0	Start C/T B	Reserved*	1	1	1	1	1	0	Start C/T D	Reserved*
0	1	1	1	1	1	Stop C/T B	Reserved*	1	1	1	1	1	1	Stop C/T D	Reserved*

NOTE:

*Reserved registers should never be read during normal operation since they are reserved for internal diagnostics.

ACR = Auxiliary control register

CR = Command register

CSR = Clock select register

CTL = Counter/timer lower

CTLR = Counter/timer lower register

CTU = Counter/timer upper

CTUR = Counter/timer upper register

MR = Mode register

SR = Status Register

THR = Tx holding register

RHR = Rx holding register

IPCR = Input port change register

ISR = Interrupt status register

IMR = Interrupt mask register

OPCR = Output port configuration register

The baud rate generator operates from the oscillator or external clock input and is capable of generating 18 commonly used data communications baud rates ranging from 50 to 38.4K baud. Thirteen of these are available simultaneously for use by the receiver and transmitter. Eight are fixed, and one of two sets of five can be selected by programming ACR[7]. The clock outputs from the BRG are at 16X the actual baud rate. The counter/timer can be used as a timer to produce a 16X clock for any other baud rate by counting down the crystal clock or an external clock. The clock selectors allow the independent selection, by the receiver and transmitter, of any of these baud rates or an external timing signal.

There are four C/Ts in the Octal UART, one for each block. The C/T operation is programmed by ACR[6:4]. One of eight timing sources can be used as the input to the C/T. The output of the C/T is available to the clock selectors and can also be programmed by OPCR[2:0] for channel a and OPCR[6:4] for channel b, to be output on the MPOa or MPOb pin respectively.

A register read address is reserved to issue a start counter/timer command and a second register read address is reserved to issue a stop counter/timer command for each timer. For example, to issue a stop counter command for the counter-timer in block B, a read of ad-

dress '1F' must be performed. See Table 1 for register addressing.

In the timer mode, the C/T generates a square wave whose period is twice the number of clock periods loaded into the C/T upper and lower registers. The counter ready bit in the ISR is set once each cycle of the square wave. If the value in CTUR or CTLR is changed, the current half-period will not be affected, but subsequent half-periods will be affected. In this mode the C/T runs continuously and does not recognize the stop C/T command (the command only resets the counter ready bit in the ISR). Receipt of a start C/T command causes the counter to ter-

Enhanced Octal Universal Asynchronous Receiver/Transmitter

2698B

minate the current timing cycle and to begin a new cycle using the values in CTUR and CTLR.

In the counter mode, the C/T counts down the number of pulses loaded into CTUR and CTLR. Counting begins upon receipt of a start counter command. Upon reaching terminal count, the counter ready bit in the ISR is set. The counter continues counting past the terminal count until stopped by the CPU. If MPO is programmed to be the output of the C/T, the output remains High until terminal count is reached, at which time it goes Low. The output returns to the High state and the counter ready bit is cleared when the counter is stopped by a stop counter command. The CPU may change the values of CTUR and CTLR at any time, but the new count becomes effective only on the next start counter command following a stop counter command. If new values have not been loaded, the previous count values are preserved and used for the next count cycle.

In the counter mode, the current value of the upper and lower eight bits of the counter may be read by the CPU. It is recommended that the counter be stopped when reading to prevent potential problems which may occur if a carry from the lower eight bits to the upper eight bits occurs between the times that both halves of the counter are read. However, a subsequent start counter command causes the counter to begin a new count cycle using the values in CTUR and CTLR.

Receiver and Transmitter

The Octal UART has eight full-duplex asynchronous receiver/transmitters. The operating frequency for the receiver and transmitter can be selected independently from the baud rate generator, the counter/timer, or from an external input.

Registers associated with the communications channel are the mode registers (MR1 and MR2), the clock select register (CSR), the command register (CR), the status register (SR), the transmit holding register (THR), and the receive holding register (RHR).

Transmitter

The transmitter accepts parallel data from the CPU and converts it to a serial bit stream on the TxD output pin. It automatically sends a start bit followed by the programmed number of data bits, an optional parity bit, and the programmed number of stop bits. The least significant bit is sent first. Following the transmission of the stop bits, if a new character is not available in the THR, the TxD output remains high and the TxEMT bit in the SR will be set to 1. Transmission resumes and the TxEMT bit is cleared when the CPU loads a new character in the THR. In the 16X clock mode, this also resynchronizes the internal 1X transmitter clock so

that transmission of the new character begins with minimum delay.

The transmitter can be forced to send a break (continuous Low condition) by issuing a start break command via the CR. The break is terminated by a stop break command. If the transmitter is disabled, it continues operating until the characters currently being transmitted and the character in the THR, if any, are completely sent out. Characters cannot be loaded in the THR while the transmitter is disabled.

Receiver

The receiver accepts serial data on the RxD pin, converts the serial input to parallel format, checks for start bit, stop bit, parity bit (if any), or break condition, and presents the assembled character to the CPU. The receiver looks for a High-to-Low (mark-to-space) transition of the start bit on the RxD input pin. If a transition is detected, the state of the RxD pin is sampled again each 16X clock for 7-1/2 clocks (16X clock mode) or at the next rising edge of the bit time clock (1X clock mode).

If RxD is sampled High, the start bit is invalid and the search for a valid start bit begins again. If RxD is still Low, a valid start bit is assumed and the receiver samples the input. This continues at one bit time intervals, at the theoretical center of the bit, until the proper number of data bits and the parity bit (if any) have been assembled, and one stop bit has been detected. The data is then transferred to the RHR and the RxDY bit in the SR is set to a one. If the character length is less than eight bits, the most significant unused bits in the RHR are set to zero.

After the stop bit is detected, the receiver will immediately look for the next start bit. However, if a non-zero character was received without a stop bit (i.e. framing error) and RxD remains low for one-half of the bit period after the stop bit was sampled, then the receiver operates as if a new start bit transition had been detected at that point (one-half bit time after the stop bit was sampled). The parity error, framing error and overrun error (if any) are strobed into the SR at the received character boundary, before the RxDY status bit is set.

If a break condition is detected (RxD is low for the entire character including the stop bit), only one character consisting of all zeros will be loaded in the FIFO and the received break bit in the SR is set to 1. The RxD input must return to a high condition for two successive clock edges of the 1X clock (internal or external) before a search for the next start bit begins.

TIMEOUT MODE

The timeout mode uses the received data stream to control the counter. Each time a received character is transferred from the shift

register to the RHR, the counter is restarted. If a new character is not received before the counter reaches zero count, the counter ready bit is set, and an interrupt can be generated. This mode can be used to indicate when data has been left in the Rx FIFO for more than the programmed time limit. Otherwise, if the receiver has been programmed to interrupt the CPU when the receive FIFO is full, and the message ends before the FIFO is full, the CPU may not know when there is data left in the FIFO. The CTU and CTL value would be programmed for just over one character time, so that the CPU would be interrupted as soon as it has stopped receiving continuous data. This mode can also be used to indicate when the serial line has been marking for longer than the programmed time limit. In this case, the CPU has read all of the characters from the FIFO, but the last character received has started the count. If there is no new data during the programmed time interval, the counter ready bit will get set, and an interrupt can be generated.

This mode is enabled by writing the appropriate command to the command register. Writing an 'Ax' to CRA or CRB will invoke the timeout mode for that channel. Writing a 'Cx' to CRA or CRB will disable the timeout mode. The timeout mode should only be used by one channel at once, since it uses the C/T. CTU and CTL must be loaded with a value greater than the normal receive character period. The timeout mode disables the regular START/STOP counter commands and puts the C/T into counter mode under the control of the received data stream. Each time a received character is transferred from the shift register to the RHR, the C/T is stopped after one C/T clock, reloaded with the value in CTU and CTL and then restarted on the next C/T clock. If the C/T is allowed to end the count before a new character has been received, the counter ready bit, ISR[3], will be set. If IMR[3] is set, this will generate an interrupt. Since receiving a character restarts the C/T, the receipt of a character after the C/T has timed out will clear the counter ready bit, ISR[3], and the interrupt. Invoking the 'Set Timeout Mode On' command, CRx=Ax', will also clear the counter ready bit and stop the counter until the next character is received.

RECEIVER FIFO

The RHR consists of a first-in-first-out (FIFO) with a capacity of three characters. Data is loaded from the receive shift register into the top-most empty position of the FIFO. The RxDY bit in the status register (SR) is set whenever one or more characters are available to be read, and a FFULL status bit is set if all three stack positions are filled with data. Either of these bits can be selected to cause an interrupt. A read of the RHR, outputs the data at the top of the FIFO. After the read cycle, the data

Enhanced Octal Universal Asynchronous Receiver/Transmitter

2698B

FIFO and its associated status bits are 'popped' thus emptying a FIFO position for new data.

In addition to the data word, three status bits (parity error, framing error, and received break) are appended to each data character in the FIFO. Status can be provided in two ways, as programmed by the error mode control bit in the mode register. In the 'character' mode, status is provided on a character-by-character basis: the status applies only to the character at the top of the FIFO. In the 'block' mode, the status provided in the SR for these three bits is the logical OR of the status for all characters coming to the top of the FIFO since the last reset error command was issued. In either mode, reading the SR does not affect the FIFO. The FIFO is 'popped' only when the RHR is read. Therefore, the SR should be read prior to reading the corresponding data character.

If the FIFO is full when a new character is received, that character is held in the receive shift register until a FIFO position is available. If an additional character is received while this state exists, the contents of the FIFO are not affected: the character previously in the shift register is lost and the overrun error status bit, SR[4], will be set upon receipt of the start bit of the new (overrunning) character.

WAKE-UP MODE

In addition to the normal transmitter and receiver operation described above, the Octal UART incorporates a special mode which provides automatic wake-up of the receiver through address frame recognition for multiprocessor communications. This mode is selected by programming bits MR1[4:3] to '11'.

In this mode of operation, a 'master' station transmits an address character followed by data characters for the addressed 'slave' station. The slave stations, whose receivers are normally disabled, examine the received data stream and 'wake-up' the CPU [by setting RxRDY] only upon receipt of an address character. The CPU compares the received address to its station address and enables the receiver if it wishes to receive the subsequent data characters. Upon receipt of another address character, the CPU may disable the receiver to initiate the process again.

A transmitted character consists of a start bit, the programmed number of data bits, an address/data (A/D) bit, and the programmed number of stop bits. The polarity of the transmitted A/D bit is selected by the CPU by programming bit MR1[2]. MR1[2] = 0 transmits a zero in the A/D bit position which identifies the corresponding data bits as data; MR1[2] = 1 transmits a one in the A/D bit position which identifies

the corresponding data bits as an address. The CPU should program the mode register prior to loading the corresponding data bits in the THR.

While in this mode, the receiver continuously looks at the received data stream, whether it is enabled or disabled. If disabled, it sets the RxRDY status bit and loads the character in the RHR FIFO if the received A/D bit is a one, but discards the received character if the received A/D bit is a zero. If enabled, all received characters are then transferred to the CPU via the RHR. In either case, the data bits are loaded in the data FIFO while the A/D bit is loaded in the status FIFO position normally used for parity error (SR[5]). Framing error, overrun error, and break detect operate normally whether or not the receiver is enabled.

MULTI-PURPOSE INPUT PIN AND MULTI-PURPOSE I/O PINS

The inputs to this unlatched 8-bit port for each block can be read by the CPU, by performing a read operation as shown in Table 1. A High input results in a logic one, while a Low input results in a logic zero. When the input port pins are read on the 84-pin LLCC, they will appear on the data bus in alternating pairs (i.e., DB0 = MP10a, DB1 = MP11a, DB2 = MP10b, DB3 = MP11b, DB4 = MPP1a, DB5 = MPP2a, DB6 = MPP1b, DB7 = MPP2b. Although this example is shown for input port 'A', all ports will have a similar order).

The MPI pin can be programmed as an input to one of several Octal UART circuits. The function of the pin is selected by programming the appropriate control register. Change-of-state detectors are provided for MPI0 and MPI1 for each channel in each block. A High-to-Low or Low-to-High transition of the inputs lasting longer than 25 to 50µs sets the MPI change-of-state bit in the interrupt status register. The bit is cleared via a command. The change-of-state can be programmed to generate an interrupt to the CPU by setting the corresponding bit in the interrupt mask register.

The input port pulse detection circuitry uses a 38.4KHz sampling clock, derived from one of the baud rate generator taps. This produces a sampling period of slightly more than 25µs (assuming a 3.6864MHz oscillator input). The detection circuitry, in order to guarantee that a true change in level has occurred, requires two successive samples be observed at the new logic level. As a consequence, the minimum duration of the signal change is 25µs if the transition occurs coincident with the first sample pulse. (The 50µs time refers to the condition

where the change-of-state is just missed and the first change of state is not detected until after an additional 25µs.)

The multi-purpose pins can be programmed as inputs or outputs using OPCR[7]. When programmed as inputs, the functions of the pins are selected by programming the appropriate control registers. When programmed as outputs, the two MPP1 pins (per block) will provide the transmitter ready (TxRDY) status for each channel and the MPP2 pins will provide the receiver ready or FIFO full (RxRDY/FFULL) status for each channel.

MULTI-PURPOSE OUTPUT PIN

This pin can be programmed to serve as a request-to-send output, the counter/timer output, the output for the 1X or 16X transmitter or receiver clocks, the TxRDY output or the RxRDY/FFULL output (see OPCR[2:0] and OPCR[6:4] – MPO Output Select).

REGISTERS

The operation of the Octal UART is programmed by writing control words into the appropriate registers. Operational feedback is provided via status registers which can be read by the CPU. Addressing of the registers is described in Table 1.

The bit formats of the Octal UART registers are depicted in Table 2. These are shown for block A. The bit format for the other blocks is the same.

MR1 – Mode Register 1

MR1 is accessed when the MR pointer points to MR1. The pointer is set to MR1 by RESET or by a set pointer command applied via the CR. After reading or writing MR1, the pointers are set at MR2.

MR1[7] – Receiver Request-to-Send Control

This bit controls the deactivation of the RTSN output (MPO) by the receiver. This output is manually asserted and negated by commands applied via the command register. MR1[7] = 1 causes RTSN to be automatically negated upon receipt of a valid start bit if the receiver FIFO is full. RTSN is reasserted when an empty FIFO position is available. This feature can be used to prevent overrun in the receiver by using the RTSN output signal to control the CTS input of the transmitting device.

MR1[6] – Receiver Interrupt Select

This bit selects either the receiver ready status (RxRDY) or the FIFO full status (FFULL) to be used for CPU interrupts.

Enhanced Octal Universal Asynchronous Receiver/Transmitter

2698B

MR1[5] – Error Mode Select

This bit selects the operating mode of the three FIFOed status bits (FE, PE, received break). In the character mode, status is provided on a character-by-character basis; the status applies only to the character at the top of the FIFO. In the block mode, the status provided in the SR for these bits is the accumulation (logical-OR) of the status for all characters coming to the top of the FIFO since the last reset error command was issued.

MR1[4:3] – Parity Mode Select

If 'with parity' or 'force parity' is selected, a parity bit is added to the transmitted character and the receiver performs a parity check on incoming data. MR1[4:3] = 11 selects the channel to operate in the special wake-up mode.

MR1[2] – Parity Type Select

This bit selects the parity type (odd or even) if the 'with parity' mode is programmed by MR1[4:3], and the polarity of the forced parity bit if the 'force parity' mode is programmed. It has no effect if the 'no parity' mode is programmed. In the special 'wake-up' mode, it selects the polarity of the transmitted A/D bit.

MR1[1:0] – Bits Per Character Select

This field selects the number of data bits per character to be transmitted and received. The character length does not include the start, parity, and stop bits.

MR2 – Mode Register 2

MR2 is accessed when the channel MR pointer points to MR2, which occurs after any access to MR1. Accesses to MR2 do not change the pointer.

MR2[7:6] – Mode Select

The Octal UART can operate in one of four modes. MR2[7:6] = 00 is the normal mode, with the transmitter and receiver operating independently. MR2[7:6] = 01 places the channel in the automatic echo mode, which automatically retransmits the received data. The following conditions are true while in automatic echo mode:

- Received data is reclocked and retransmitted on the Tx/D output.
- The receive clock is used for the transmitter.
- The receiver must be enabled, but the transmitter need not be enabled.
- The TxRDY and TxEMT status bits are inactive.
- The received parity is checked, but is not regenerated for transmission, i.e., transmitted parity bit is as received.
- Character framing is checked, but the stop bits are retransmitted as received.

Table 2. Register Bit Formats

Bit 7	Bit 6	Bit 5	Bit 4	Bit 3	Bit 2	Bit 1	Bit 0
-------	-------	-------	-------	-------	-------	-------	-------

MR1 (Mode Register 1)

RxRTS Control	RxINT Select	Error Mode	Parity Mode	Parity Type	Bits per Character
0 = No 1 = Yes	0 = RxRDY 1 = FFULL	0 = Char 1 = Block	00 = With parity 01 = Force parity 10 = No parity 11 = Special mode	0 = Even 1 = Odd	00 = 5 01 = 6 10 = 7 11 = 8

MR2 (Mode Register 2)

Channel Mode	TxRTS Control	CTS Enable Tx	Stop Bit Length*
00 = Normal 01 = Auto-echo 10 = Local loop 11 = Remote loop	0 = No 1 = Yes	0 = No 1 = Yes	0 = 0.563 4 = 0.813 8 = 1.563 C = 1.813 1 = 0.625 5 = 0.875 9 = 1.625 C = 1.875 2 = 0.688 6 = 0.938 A = 1.688 E = 1.938 3 = 0.750 7 = 1.000 B = 1.750 F = 2.000

NOTE:

*Add 0.5 to values shown above for 0-7, if channel is programmed for 5 bits/char.

CSR (Clock Select Register)

Receiver Clock Select	Transmitter Clock Select
See text	See text

CR (Command Register)

Miscellaneous Commands	Disable Tx	Enable Tx	Disable Rx	Enable Rx
See text	0 = No 1 = Yes	0 = No 1 = Yes	0 = No 1 = Yes	0 = No 1 = Yes

SR (Status Register)

Rec'd. Break	Framing Error	Parity Error	Overrun Error	TxEMT	TxRDY	FFULL	RxRDY
0 = No 1 = Yes	0 = No 1 = Yes	0 = No 1 = Yes	0 = No 1 = Yes	0 = No 1 = Yes	0 = No 1 = Yes	0 = No 1 = Yes	0 = No 1 = Yes

NOTE:

*These status bits are appended to the corresponding data character in the receive FIFO. A read of the status register provides these bits [7:5] from the top of the FIFO together with bits [4:0]. These bits are cleared by a reset error status command. In character mode, they must be reset when the corresponding data character is read from the FIFO.

OPCR (Output Port Configuration Register)

MPP Function Select	MPOb Pin Function Select	Power-Down Mode	MPOa Pin Function Select
0 = input 1 = output	000 = RTSN 001 = C/TO 010 = TxC (1X) 011 = TxC (16X) 100 = RxC (1X) 101 = RxC (16X) 110 = TxRDY 111 = RxRDY/FF	0 = Off 1 = On	000 = RTSN 001 = C/TO 010 = TxC (1X) 011 = TxC (16X) 100 = RxC (1X) 101 = RxC (16X) 110 = TxRDY 111 = RxRDY/FF

NOTE:

*Only OPCR[3] in block A controls the power-down mode.

- A received break is echoed as received until the next valid start bit is detected.
- CPU-to-receiver communication continues normally, but the CPU-to-transmitter link is disabled.

Enhanced Octal Universal Asynchronous Receiver/Transmitter

2698B

Two diagnostic modes can also be selected. MR2[7:6] = 10 selects local loopback mode. In this mode:

1. The transmitter output is internally connected to the receiver input.
2. The transmit clock is used for the receiver.
3. The TxD output is held high.
4. The RxD input is ignored.
5. The transmitter must be enabled, but the receiver need not be enabled.
6. CPU to transmitter and receiver communications continue normally.

The second diagnostic mode is the remote loopback mode, selected by MR2[7:6] = 11. In this mode:

1. Received data is relocked and retransmitted on the TXD output.
2. The receive clock is used for the transmitter.
3. Received data is not sent to the local CPU, and the error status conditions are inactive.
4. The received parity is not checked and is not regenerated for transmission, i.e., the transmitted parity bit is as received.
5. The receiver must be enabled, but the transmitter need not be enabled.
6. Character framing is not checked, and the stop bits are retransmitted as received.
7. A received break is echoed as received until the next valid start bit is detected.

When switching in and out of the various modes, the selected mode is activated at the completion of all transmitted and received characters. Likewise, if a mode is deselected, the device will switch out of the mode at the completion of all transmit and/or receive characters.

MR2[5] – Transmitter Request-to-Send Control

This bit controls the deactivation of the RTSN output (MPO) by the transmitter. This output is manually asserted and negated by appropriate commands issued via the command register. MR2[5] = 1 causes RTSN to be reset automatically one bit time after the characters in the transmit shift register and in the THR (if any) are completely transmitted (includes the programmed number of stop bits if the transmitter is not enabled). This feature can be used to automatically terminate the transmission as follows:

1. Program auto-reset mode: MR2[5] = 1.
2. Enable transmitter.
3. Assert RTSN via command.
4. Send message.
5. Verify the next to last character of the message is being sent by waiting until transmitter ready is asserted. Disable transmitter after the last character of the message is loaded in the THR.

Table 2. Register Bit Formats (Continued)

Bit 7	Bit 6	Bit 5	Bit 4	Bit 3	Bit 2	Bit 1	Bit 0
-------	-------	-------	-------	-------	-------	-------	-------

ACR (Auxiliary Control Register)

BRG Set Select	Counter/Timer Mode and Source	Delta MPI1bINT	Delta MPI0bINT	Delta MPI1aINT	Delta MPI0aINT
0 = set 1 1 = set 2	See text	0 = off 1 = on	0 = off 1 = on	0 = off 1 = on	0 = off 1 = on

IPCR (Input Port Change Register)

Delta MPI1b	Delta MPI0b	Delta MPI1a	Delta MPI0a	MPI1b	MPI0b	MPI1a	MPI0a
0 = No 1 = Yes	0 = No 1 = Yes	0 = No 1 = Yes	0 = No 1 = Yes	0 = Low 1 = High	0 = Low 1 = High	0 = Low 1 = High	0 = Low 1 = High

ISR (Interrupt Status Register)

MPI Port Change	Delta BREAKb	RxRDY/FFULLb	TxDYb	Counter Ready	Delta BREAKa	RxRDY/FFULLa	TxDYa
0 = No 1 = Yes	0 = No 1 = Yes	0 = No 1 = Yes	0 = No 1 = Yes	0 = No 1 = Yes	0 = No 1 = Yes	0 = No 1 = Yes	0 = No 1 = Yes

IMR (Interrupt Mask Register)

MPI Port Change INT	Delta BREAKb INT	RxRDY/FFULLb INT	TxDYb INT	Counter Ready INT	Delta BREAKa INT	RxRDY/FFULLa INT	TxDYa INT
0 = off 1 = on	0 = off 1 = on	0 = off 1 = on	0 = off 1 = on	0 = off 1 = on	0 = off 1 = on	0 = off 1 = on	0 = off 1 = on

CTUR (Counter/Timer Upper Register)

C/T[15]	C/T[14]	C/T[13]	C/T[12]	C/T[11]	C/T[10]	C/T[9]	C/T[8]

CTLR (Counter/Timer Lower Register)

C/T[7]	C/T[6]	C/T[5]	C/T[4]	C/T[3]	C/T[2]	C/T[1]	C/T[0]

IPR (Input Port Register)

MPP2b	MPP1b	MPP2a	MPP1a	MPI1b	MPI0b	MPI1a	MPI0a
0 = Low 1 = High	0 = Low 1 = High	0 = Low 1 = High	0 = Low 1 = High	0 = Low 1 = High	0 = Low 1 = High	0 = Low 1 = High	0 = Low 1 = High

6. The last character will be transmitted and RTSN will be reset one bit time after the last stop bit.

that character. This feature can be used to prevent overrun of a remote receiver.

MR2[4] – Clear-to-Send Control

The state of this bit determines if the CTSN input (MPI) controls the operation of the transmitter. If this bit is 0, CTSN has no effect on the transmitter. If this bit is a 1, the transmitter checks the state of CTSN each time it is ready to send a character. If it is asserted (Low), the character is transmitted. If it is negated (High), the TxD output remains in the marking state and the transmission is delayed until CTSN goes Low. Changes in CTSN, while a character is being transmitted do not affect the transmission of

MR2[3:0] – Stop Bit Length Select

This field programs the length of the stop bit appended to the transmitted character. Stop bit lengths of 9/16 to 1 and 1–9/16 to 2 bits, in increments of 1/16 bit, can be programmed for character lengths of 6, 7, and 8 bits. For a character length of 5 bits, 1–1/16 to 2 stop bits can be programmed in increments of 1/16 bit. In all cases, the receiver only checks for a mark condition at the center of the first stop bit position (one bit time after the last data bit, or after the parity bit if parity is enabled). If an external 1X clock is used for the transmitter, MR2[3] = 0 selects one

Enhanced Octal Universal Asynchronous Receiver/Transmitter

2698B

stop bit and MR2[3] = 1 selects two stop bits to be transmitted.

CSR – Clock Select Register

CSR[7:4] – Receiver Clock Select

When using a 3.6864MHz crystal or external clock input, this field selects the baud rate clock for the receiver as shown in Table 3.

Table 3. Baud Rate

CSR[7:4]	ACR[7] = 0	ACR[7] = 1
0000	50	75
0001	110	110
0010	134.5	38.4k
0011	200	150
0100	300	300
0101	600	600
0110	1,200	1,200
0111	1,050	2,000
1000	2,400	2,400
1001	4,800	4,800
1010	7,200	1,800
1011	9,600	9,600
1100	38.4k	19.2k
1101	Timer	Timer
1110	MP2 – 16X	MP2 – 16X
1111	MP2 – 1X	MP2 – 1X

The receiver clock is always a 16X clock, except for CSR[7:4] = 1111. When MPP2 is selected as the input, MPP2a is for channel a and MPP2b is for channel b.

CSR[3:] – Transmitter Clock Select

This field selects the baud rate clock for the transmitter. The field definition is as shown in Table 3, except as follows:

CSR[3:0]	ACR[7] = 0	ACR[7] = 1
1110	MPP1 – 16X	MPP1 – 16X
1111	MPP1 – 1X	MPP1 – 1X

When MPP1 is selected as the input, MPP1a is for channel a and MPP1b is for channel b.

CR – Command Register

CR is used to write commands to the Octal UART.

CR[7:4] – Miscellaneous Commands

The encoded value of this field can be used to specify a single command as follows:

- 0000 No command.
- 0001 Reset MR pointer. Causes the MR pointer to point to MR1.
- 0010 Reset receiver. Resets the receiver as if a hardware reset had been applied. The receiver is disabled and the FIFO pointer is reset to the first location.
- 0011 Reset transmitter. Resets the transmitter as if a hardware reset had been applied.

0100 Reset error status. Clears the received break, parity error, framing error, and overrun error bits in the status register (SR[7:4]). Used in character mode to clear OE status (although RB, PE, and FE bits will also be cleared), and in block mode to clear all error status after a block of data has been received.

0101 Reset break change interrupt. Causes the break detect change bit in the interrupt status register (ISR[2 or 6]) to be cleared to zero.

0110 Start break. Forces the Tx/D output low (spacing). If the transmitter is empty, the start of the break condition will be delayed up to two bit times. If the transmitter is active, the break begins when transmission of the character is completed. If a character is in the THR, the start of break is delayed until that character or any others loaded after it have been transmitted (TxEMT must be true before break begins). The transmitter must be enabled to start a break

0111 Stop break. The Tx/D line will go high (marking) within two bit times. Tx/D will remain high for one bit time before the next character, if any, is transmitted.

1000 Assert RTSN. Causes the RTSN output to be asserted (Low).

1001 Negate RTSN. Causes the RTSN output to be negated (High).

1010 Set Timeout Mode On. The register in this channel will restart the C/T as each receive character is transferred from the shift register to the RHR. The C/T is placed in the counter mode, the START/STOP counter commands are disabled, the counter is stopped, and the Counter Ready Bit, ISR[3], is reset.

1011 Reserved.

1100 Disable Timeout Mode. This command returns control of the C/T to the regular START/STOP counter commands. It does not stop the counter, or clear any pending interrupts. After disabling the timeout mode, a 'Stop Counter' command should be issued.

1101 Reserved.

111x Reserved for testing.

CR[3] – Disable Transmitter

This command terminates transmitter operation and resets the TxRDY and TxEMT status bits. However, if a character is being transmitted or if a character is in the THR when the transmitter is disabled, the transmission of the character(s) is completed before assuming the inactive state.

CR[2] – Enable Transmitter

Enables operation of the transmitter. The TxRDY status bit will be asserted.

CR[1] – Disable Receiver

This command terminates operation of the receiver immediately – a character being received will be lost. The command has no effect on the receiver status bits or any other control registers. If the special wake-up mode is programmed, the receiver operates even if it is disabled (see Wake-up Mode).

CR[0] – Enable Receiver

Enables operation of the receiver. If not in the special wake-up mode, this also forces the receiver into the search for start bit state.

SR – Channel Status Register

SR[7] – Received Break

This bit indicates that an all zero character of the programmed length has been received without a stop bit. Only a single FIFO position is occupied when a break is received; further entries to the FIFO are inhibited until the RxDA line returns to the marking state for at least one-half bit time (two successive edges of the internal or external 1x clock).

When this bit is set, the change in break bit in the ISR (ISR[6 or 2]) is set. ISR[6 or 2] is also set when the end of the break condition, as defined above, is detected. The break detect circuitry is capable of detecting breaks that originate in the middle of a received character. However, if a break begins in the middle of a character, it must last until the end of the next character in order for it to be detected.

SR[6] – Framing Error (FE)

This bit, when set, indicates that a stop bit was not detected when the corresponding data character in the FIFO was received. The stop bit check is made in the middle of the first stop bit position.

SR[5]– Parity Error (PE)

This bit is set when the 'with parity' or 'force parity' mode is programmed and the corresponding character in the FIFO was received with incorrect parity. In special 'wake-up mode', the parity error bit stores the received A/D bit.

SR[4] – Overrun Error (OE)

This bit, when set, indicates that one or more characters in the received data stream have been lost. It is set upon receipt of a new character when the FIFO is full and a character is already in the receive shift register waiting for an empty FIFO position. When this occurs, the character in the receive shift register (and its break detect, parity error and framing error status, if any) is lost. This bit is cleared by a reset error status command.

Enhanced Octal Universal Asynchronous Receiver/Transmitter

2698B

SR[3] – Transmitter Empty (TxEMT)

This bit will be set when the transmitter under-
runs, i.e., both the transmit holding register and
the transmit shift register are empty. However,
this bit is not set until one character has been
transmitted. It is set after transmission of the
last stop bit of a character. If no character is in
the THR awaiting transmission. It is reset when
the THR is loaded by the CPU, or when the
transmitter is disabled.

SR[2] – Transmitter Ready (TxRDY)

This bit, when set, indicates that the THR is
empty and ready to be loaded with a character.
This bit is cleared when the THR is loaded by
the CPU and is set when the character is trans-
ferred to the transmit shift register. TxRDY is re-
set when the transmitter is disabled and is set
when the transmitter is first enabled, e.g., char-
acters loaded in the THR while the transmitter
is disabled will not be transmitted.

SR[1] – FIFO Full (FFULL)

This bit is set when a character is transferred
from the receive shift register to the receive
FIFO and the transfer causes the FIFO to be-
come full, i.e., all three FIFO positions are occu-
pied. It is reset when the CPU reads the FIFO
and there is no character in the receive shift
register. If a character is waiting in the receive
shift register because the FIFO is full, FFULL is
not reset after reading the FIFO once.

SR[0] – Receiver Ready (RxRDY)

This bit indicates that a character has been re-
ceived and is waiting in the FIFO to be read by
the CPU. It is set when the character is trans-
ferred from the receive shift register to the FIFO
and reset when the CPU reads the RHR, and
no more characters are in the FIFO.

OPCR – Output Port Configuration Register

OPCR[7] – MPP Function Select

When this bit is a zero, the MPP pins function
as inputs, to be used as general purpose inputs
or as receiver or transmitter external clock in-
puts. When this bit is set, the MPP pins function
as outputs. MPP1 will be a TxRDY indicator,
and MPP2 will be an RxRDY/FFULL indicator.

OPCR[6:4] – MPOb Output Select

This field programs the MPOb output pin to pro-
vide one of the following:

- 000 Request-to-send active-Low out-
put (RTSN). This output is as-
serted and negated via the com-
mand register. Mode RTSN can be
programmed to be automatically
reset after the character in the
transmitter is completely shifted
out or when the receiver FIFO and
receiver shift register are full using
MR2[5] and MR1[7], respectively.

- 001 The counter/timer output. In the
timer mode, this output is a square
wave with a period of twice the val-
ue (in clock periods) of the con-
tents of the CTUR and CTLR. In
the counter mode, the output re-
mains high until the terminal count
is reached, at which time it goes
low. The output returns to the High
state when the counter is stopped
by a stop counter command.
- 010 The 1X clock for the transmitter,
which is the clock that shifts the
transmitted data. If data is not be-
ing transmitted, a non-synchro-
nized 1X clock is output.
- 011 The 16X clock for the transmitter.
This is the clock selected by
CSR[3:0], and is a 1X clock if
CSR[3:0] = 1111.
- 100 The 1X clock for the receiver,
which is the clock that samples the
received data. If data is not being
received, a non-synchronized 1X
clock is output.
- 101 The 16X clock for the receiver. This
is the clock selected by CSR[7:4],
and is a 1X clock if CSR[7:4] =
1111.
- 110 The transmitter register empty sig-
nal, which is the same as SR[3].
- 111 The receiver ready or FIFO full sig-
nal.

OPCR[3] – Power Down Mode Select

This bit, when set, selects the power-down
mode. In this mode, the 2698B oscillator is
stopped and all functions requiring this clock
are suspended. The contents of all registers are
saved. It is recommended that the transmitter
and receiver be disabled prior to placing the
2698B in this mode. This bit is reset with RE-
SET asserted. Note that this bit must be set to
a logic 1 after power up. Only OPCR[3] in block
A controls the power-down mode.

OPCR[2:0] – MPOa Output Select

This field programs the MPOa output pin to pro-
vide one of the same functions as described in
OPCR[6:4].

ACR – Auxiliary Control Register

ACR[7] – Baud Rate Generator Set Select

This bit selects one of two sets of baud rates
generated by the BRG.

- Set 1: 50, 110, 134.5, 200, 300, 600,
1.05k, 1.2k, 2.4k, 4.8k, 7.2k, 9.6k,
and 38.4k baud.
- Set 2: 75, 110, 150, 300, 600, 1.2k, 1.8k,
2.0k, 2.4k, 4.8k, 9.6k, 19.2k, and
38.4k baud.

The selected set of rates is available for use by
the receiver and transmitter.

ACR[6:4] – Counter/Timer Mode and Clock Source Select

This field selects the operating mode of the
counter/timer and its clock source (see Table
4).

The MPI pin available as the clock source is
MPI a,c,e, and g only.

Table 4. ACR[6:4] Operating Mode

[6:4]	Mode	Clock Source
0 0 0	Counter	MPI pin
0 0 1	Counter	MPI pin divided by 16
0 1 0	Counter	TxC-1X clock of the transmitter
0 1 1	Counter	Crystal or external clock (X1/CLK) divided by 16
1 0 0	Timer	MPI pin
1 0 1	Timer	MPI pin divided by 16
1 1 0	Timer	Crystal or external clock (X1/CLK)
1 1 1	Timer	Crystal or external clock (X1/CLK) divided by 16

ACR[3:0] – MPI1b, MPI0b, MPI1a, MPI0a Change-of-State Interrupt Enable

This field selects which bits of the input port
change register (IPCR) cause the input change
bit in the interrupt status register, ISR[7], to be
set. If a bit is in the 'on' state, the setting of the
corresponding bit in the IPCR will also result in
the setting of ISR[7], which results in the gener-
ation of an interrupt output if IMR[7] = 1. If a bit
is in the 'off' state, the setting of that bit in the
IPCR has no effect on ISR[7].

IPCR – Input Port Change Register

IPCR[7:4] – MPI1b, MPI0b, MPI1a, MPI0a Change-of-State

These bits are set when a change of state, as
defined in the Input Port section of this data
sheet, occurs at the respective pins. They are
cleared when the IPCR is read by the CPU. A
read of the IPCR also clears ISR[7], the input
change bit in the interrupt status register. The
setting of these bits can be programmed to gen-
erate an interrupt to the CPU.

IPCR[3:0] – MPI1b, MPI0b, MPI1a, MPI0a Change-of-State

These bits provide the current state of the re-
spective inputs. The information is unlatched
and reflects the state of the inputs pins at the
time the IPCR is read.

Enhanced Octal Universal Asynchronous Receiver/Transmitter

2698B

ISR – Interrupt Status Register

This register provides the status of all potential interrupt sources. The contents of this register are masked by the interrupt mask register (IMR). If a bit in the ISR is a '1' and the corresponding bit in the IMR is also a '1', the INTRN output is asserted (Low). If the corresponding bit in the IMR is a zero, the state of the bit in the ISR has no effect on the INTRN output. Note that the IMR does not mask the reading of the ISR; the true status is provided regardless of the contents of the IMR.

ISR[7] – MPI Change-of-State

This bit is set when a change-of-state occurs at the MPI1b, MPI0b, MPI1a, MPI0a input pins. It is reset when the CPU reads the IPCR.

ISR[6] – Channel b Change In Break

This bit, when set, indicates that the receiver has detected the beginning or the end of a received break. It is reset when the CPU issues a reset break change interrupt command.

ISR[5] – Receiver Ready or FIFO Full Channel b

The function of this bit is programmed by MR1[6]. If programmed as receiver ready, it indicates that a character has been received and is waiting in the FIFO to be read by the CPU. It is set when the character is transferred from the receive shift register to the FIFO and reset when the CPU reads the receiver FIFO. If the FIFO contains more characters, the bit will be set again after the FIFO is read.

If programmed as FIFO full, it is set when a character is transferred from the receive holding register to the receive FIFO and the transfer causes the FIFO to become full, i.e., all three FIFO positions are occupied. It is reset when FIFO is read and there is no character in the receiver shift register. If there is a character waiting in the receive shift register because the FIFO is full, the bit is set again when the waiting character is transferred into the FIFO.

ISR[4] – Transmitter Ready Channel b

This bit is a duplicate of TxRDY (SR[2]).

ISR[3] – Counter Ready

In the counter mode of operation, this bit is set when the counter reaches terminal count and is reset when the counter is stopped by a stop counter command. It is initialized to '0' when the chip is reset.

In the timer mode, this bit is set once each cycle of the generated square wave (every other time

the C/T reaches zero count). The bit is reset by a stop counter command. The command, however, does not stop the C/T.

ISR[2] – Channel a Change In Break

This bit, when set, indicates that the receiver has detected the beginning or the end of a received break. It is reset when the CPU issues a reset break change interrupt command.

ISR[1] – Receiver Ready or FIFO Full Channel a

The function of this bit is programmed by MR1[6]. If programmed as receiver ready, it indicates that a character has been received and is waiting in the FIFO to be read by the CPU. It is set when the character is transferred from the receive shift register to the FIFO and reset when the CPU reads the receiver FIFO. If the FIFO contains more characters, the bit will be set again after the FIFO is read. If programmed as FIFO full, it is set when a character is transferred from the receive holding register to the receive FIFO and the transfer causes the FIFO to become full, i.e., all three FIFO positions are occupied. It is reset when FIFO is read and there is no character in the receiver shift register. If there is a character waiting in the receive shift register because the FIFO is full, the bit is set again when the waiting character is transferred into the FIFO.

ISR[0] – Transmitter Ready Channel a

This bit is a duplicate of TxRDY (SR[2]).

IMR – Interrupt Mask Register

The programming of this register selects which bits in the ISR cause an interrupt output. If a bit in the ISR is a '1' and the corresponding bit in the IMR is a '1', the INTRN output is asserted (Low). If the corresponding bit in the IMR is a zero, the state of the bit in the ISR has no effect on the INTRN output. Note that the IMR does not mask reading of the ISR.

CTUR and CTLR – Counter/Timer Registers

The CTUR and CTLR hold the eight MSBs and eight LSBs, respectively, of the value to be used by the counter/timer in either the counter or timer modes of operation. The minimum value which may be loaded into the CTUR/CTLR registers is H'0002'. Note that these registers are write-only and cannot be read by the CPU.

In the timer (programmable divider) mode, the C/T generates a square wave with a period of twice the value (in clock periods) of the CTUR and CTLR. If the value in CTUR or CTLR is changed, the current half-period will not be affected, but subsequent half-periods will be. The C/T will not be running until it receives an initial 'Start Counter' command (read at address A3-A0 = 1110). After this, while in timer mode, the C/T will run continuously. Receipt of a subsequent start counter command causes the C/T to terminate the current timing cycle and to begin a new cycle using the values in the CTUR and CTLR.

The counter ready status bit (ISR[3]) is set once each cycle of the square wave. The bit is reset by a stop counter command read with A3-A0 = H'F'. The command, however, does not stop the C/T. The generated square wave is output on MPO if it is programmed to be the C/T output.

In the counter mode, the C/T counts down the number of pulses loaded in CTUR and CTLR by the CPU. Counting begins upon receipt of a start counter command. Upon reaching the terminal count H'0000', the counter ready interrupt bit (ISR[3]) is set. The counter continues counting past the terminal count until stopped by the CPU. If MPO is programmed to be the output of the C/T, the output remains High until the terminal count is reached, at which time it goes Low. The output returns to the High state and ISR[3] is cleared when the counter is stopped by a stop counter command. The CPU may change the values of CTUR and CTLR at any time, but the new count becomes effective only on the next start counter command. If new values have not been loaded, the previous values are preserved and used for the next count cycle.

In the counter mode, the current value of the upper and lower eight bits of the counter (CTU, CTL) may be read by the CPU. It is recommended that the counter be stopped when reading to prevent potential problems which may occur if a carry from the lower eight bits to the upper eight bits occurs between the times that both halves of the counter is read. However, note that a subsequent start counter command will cause the counter to begin a new count cycle using the values in CTUR and CTLR.

Enhanced Octal Universal Asynchronous Receiver/Transmitter**2698B****ABSOLUTE MAXIMUM RATINGS¹**

SYMBOL	PARAMETER	RATING	UNIT
T _{STG}	Storage temperature range	-65 to +150	°C
V _{CC}	Voltage from V _{CC} to GND ²	-0.5 to +7.0	V
V _S	Voltage from any pin to ground ³	-0.5 to V _{CC} +0.5	V

RECOMMENDED OPERATING CONDITIONS

SYMBOL	PARAMETER	LIMITS			UNIT
		Min	Nom	Max	
V _{CC}	Supply Voltage	4.5	5.0	5.5	V
V _{IH}	High-level input voltage (except X1/CLK)	2.0			V
V _{IH}	High-level input voltage (X1/CLK)	4.0			V
V _{IL}	Low-level input voltage			0.8	V
I _{OL}	Low-level output current			2.4	mA
I _{OH1}	High-level output current			-400	μA
I _{OH2}	High-level output current			-100	μA
T _A	Operating free air temperature range ²	-55		+125	°C

Enhanced Octal Universal Asynchronous Receiver/Transmitter

2698B

DC ELECTRICAL CHARACTERISTICS⁴ $-55^{\circ}\text{C} \leq T_A \leq +125^{\circ}\text{C}$, $4.5\text{V} \leq V_{CC} \leq 5.5\text{V}$

SYMBOL	PARAMETER	TEST CONDITIONS	LIMITS			UNIT
			Min	Typ	Max	
V_{OL}	Output Low voltage	$V_{CC} = \text{MIN}, I_{OL} = \text{MAX}$			0.4	V
V_{OH}	Output High voltage (except OD outputs)	$V_{CC} = \text{MIN}, I_{OH1} = \text{MAX}, I_{OH2} = \text{MAX}$	$0.8V_{CC}$ $0.9V_{CC}$			V V
I_{IL}	Input current Low, MPI and MPP pins	$V_{CC} = \text{MAX}, V_{IN} = 0$	-65			μA
I_{IH}	Input current High, MPI and MPP pins	$V_{CC} = \text{MAX}, V_{IN} = V_{CC}$			20	μA
I_I	Input leakage current	$V_{CC} = \text{MAX}, V_{IN} = 0 \text{ to } V_{CC}$	-10		10	μA
I_{ILX1}	X1/CLK input Low current	$V_{CC} = \text{MAX}, V_{IN} = \text{GND}, X2 = \text{open}$	-100			μA
I_{IHX1}	X1/CLK input High current	$V_{IN} = V_{CC}, X23 = \text{open}, V_{CC} = \text{MAX}$			100	μA
I_{OZH}	Output off current High, 3-state data bus	$V_{CC} = \text{MAX}, V_{IN} = V_{CC}$			10	μA
I_{OZL}	Output off current Low, 3-state data bus	$V_{CC} = \text{MAX}, V_{IN} = 0$	-10			μA
I_{ODL}	Open-drain output Low current in off state: IRQN	$V_{CC} = \text{MAX}, V_{IN} = 0$	-10			μA
I_{ODH}	Open-drain output High current in off state: IRQN	$V_{IN} = V_{CC}, V_{CC} = \text{MAX}$			10	μA
I_{CC}	Power supply current Operating mode				30	mA
	Power down mode				2.4	mA

NOTES:

- Stresses above those listed under Absolute Maximum Ratings may cause permanent damage to the device. This is a stress rating only and functional operation of the device at these or any other condition above those indicated in the operation section of this specification is not implied.
- For operating at elevated temperatures, the device must be derated based on $+150^{\circ}\text{C}$ maximum junction temperature.
- This product includes circuitry specifically designed for the protection of its internal devices from damaging effects of excessive static charge. Nonetheless, it is suggested that conventional precautions be taken to avoid applying any voltages larger than the rated maxima.
- All voltage measurements are referenced to ground (GND). For testing, all inputs swing between 0.4V and 2.4V with a transition time of 20ns maximum. For X1/CLK this swing is between 0.4V and 4.4V. All time measurements are referenced at input voltages of V_{IL} and V_{IH} , as appropriate.
- Test condition for interrupt and MPP outputs: $C_L = 50\text{pF}$, $R_L = 2.7\text{kohms}$ to V_{CC} . Test conditions for rest of outputs: $C_L = 150\text{pF}$.
- Timing is illustrated and referenced to the WRN and RDN inputs. The device may also be operated with CEN as the 'strobing' input. CEN and RDN (also CEN and WRN) are ANDed internally. As a consequence, the signal asserted last initiates the cycle and the signal negated first terminates the cycle.
- If CEN is used as the 'strobing' input, the parameter defines the minimum high times between one CEN and the next. The RDN signal must be negated for t_{WAO} guarantee that any status register changes are valid.
- Consecutive write operations to the command register require at least three rising edges of the X1 clock between writes.
- This value is not tested, but is guaranteed by design.

Enhanced Octal Universal Asynchronous Receiver/Transmitter

2698B

AC ELECTRICAL CHARACTERISTICS^{4, 5} $-55^{\circ}\text{C} \leq T_A \leq +125^{\circ}\text{C}$, $4.5\text{V} \leq V_{CC} \leq 5.5\text{V}$

SYMBOL	FIGURE	PARAMETER	LIMITS			UNIT
			Min	Typ	Max	
Reset timing						
t _{RES}	3	Reset pulse width	200			ns
Bus timing⁶						
t _{AS}	4	A0-A5 setup time to RDN, WRN Low	10			ns
t _{AH}	4	A0-A5 hold time from RDN, WRN High	100			ns
t _{CS} ⁷	4	CEN setup time to RDN, WRN Low	0			ns
t _{CH} ⁷	4	CEN hold time from RDN, WRN High	0			ns
t _{rw}	4	WRN, RDN pulse width Low	225			ns
t _{OD}	4	Data valid after RDN Low			200	ns
t _{OF}	4	Data bus floating after RDN High			80	ns
t _{OS}	4	Data setup time before WRN High	100			ns
t _{OH}	4	Data hold time after WRN High	10			ns
t _{rwd} ⁸	4	Time between reads and/or writes	100			ns
MPI and MPO timing⁶						
t _{PS}	5	MPI or MPP input setup time before RDN Low	0			ns
t _{PH}	5	MPI or MPP input hold time after RDN High	0			ns
t _{PD}	5	MPO output valid from WRN High RDN Low			250 250	ns ns
Interrupt timing						
t _{IR}	6	INTRN negated or MPP output High from: Read RHR (RxRDY/FFULL interrupt) Write THR (TxRDY, TxEMT interrupt) Reset command (break change interrupt) Reset command (MPI change interrupt) Stop C/T command (counter interrupt) Write IMR (clear of interrupt mask bit)			270 270 270 270 270 270	ns ns ns ns ns ns
Clock timing						
t _{CLK}	7	X1/CLK high or low time	120			ns
f _{CLK}	7	X1/CLK frequency	2.0	3.6864	4.0	mHz
t _{CTC}	7	Counter/timer clock high or low time	120			nS
f _{CTC}	7	Counter/timer clock frequency	0 ⁹		4.0	mHz
t _{Rx}	7	RxC high or low time	200			nS
f _{Rx}	7	RxC frequency (16X) RxC frequency (1X)	0 ⁹ 0 ⁹		2.0 1.0	mHz mHz
t _{Tx}	7	TxC high or low time	200			nS
f _{Tx}	7	TxC frequency (16X) TxC frequency (1X)	0 ⁹ 0 ⁹		2.0 1.0	mHz mHz
Transmitter timing						
t _{TxD}	8	TxD output delay from TxC low			350	ns
t _{TCS}	8	TxC output delay from TxD output data	0		150	ns
Receiver timing						
t _{RxS}	9	RxD data setup time to RxC high	50			ns
t _{RxH}	9	RxD data hold time from RxC high	100			ns

Enhanced Octal Universal Asynchronous Receiver/Transmitter

2698B

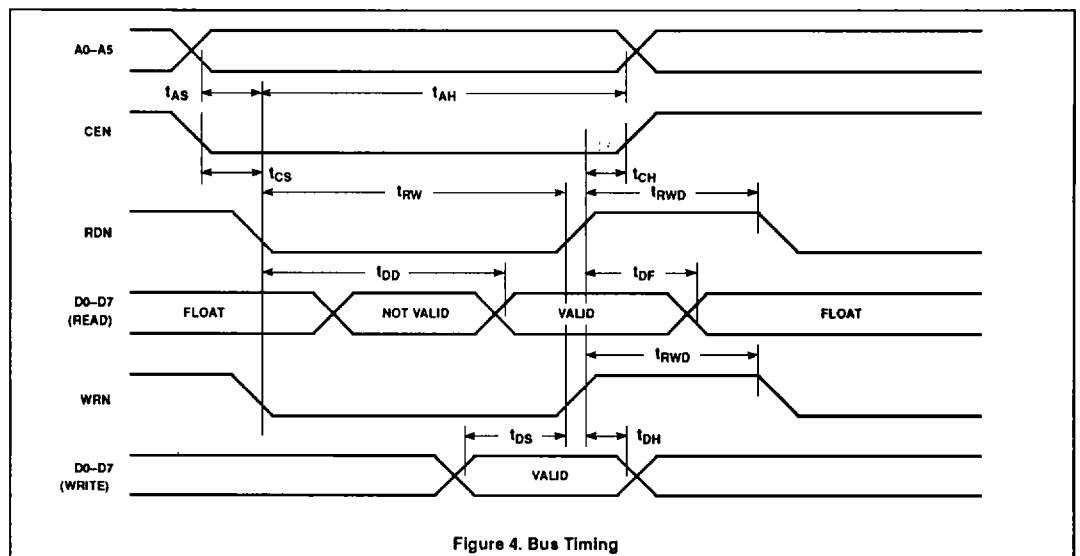
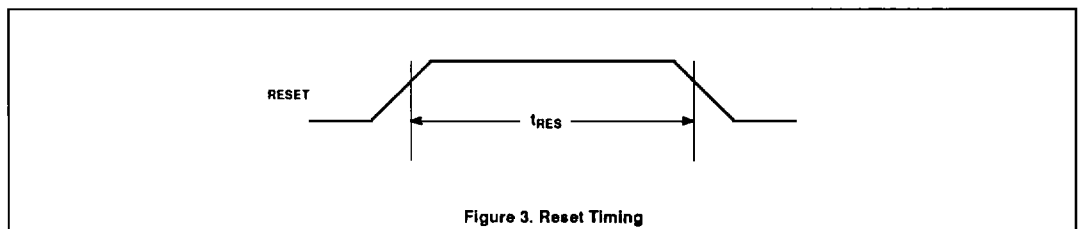
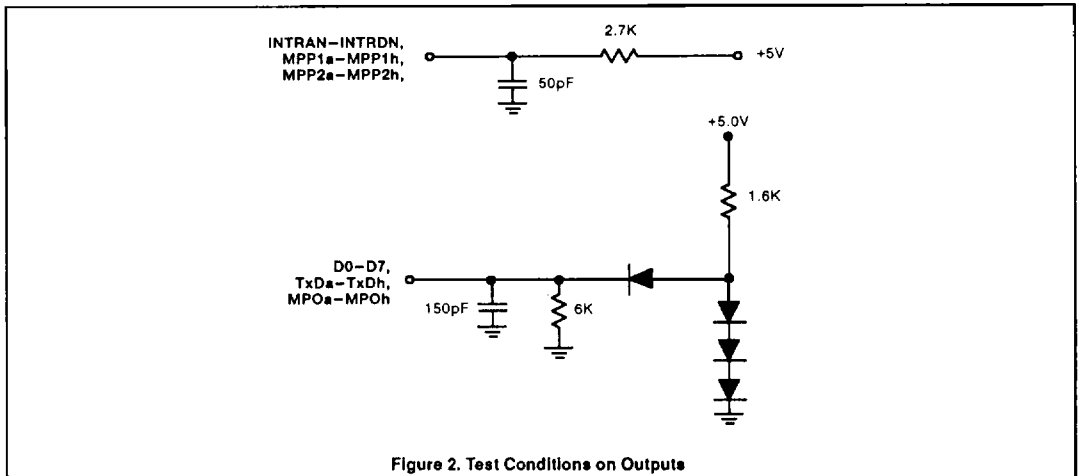

Enhanced Octal Universal Asynchronous Receiver/Transmitter

2698B

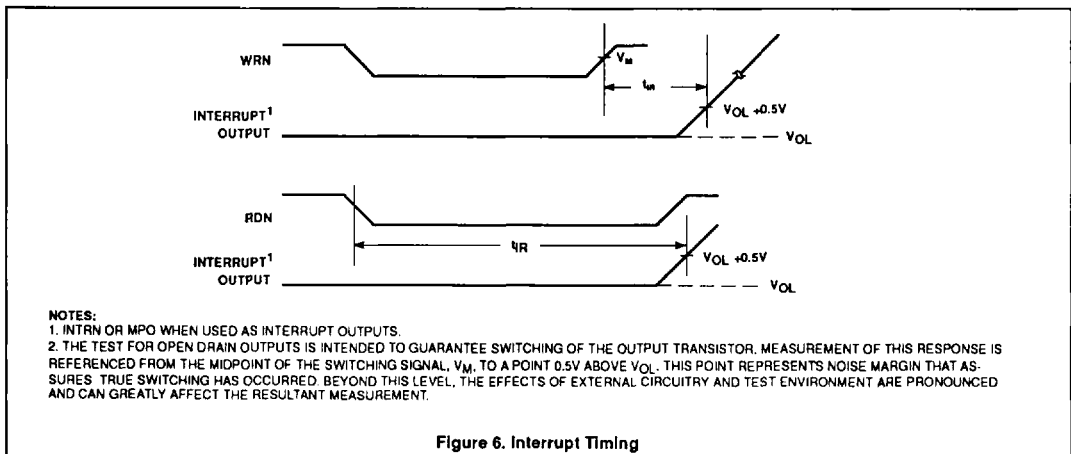
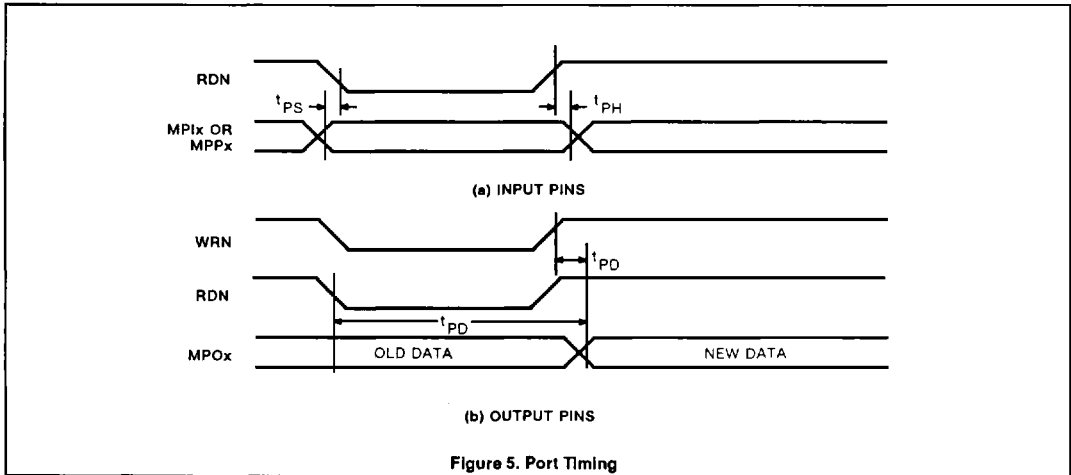

Enhanced Octal Universal Asynchronous Receiver/Transmitter 2698B

2698B

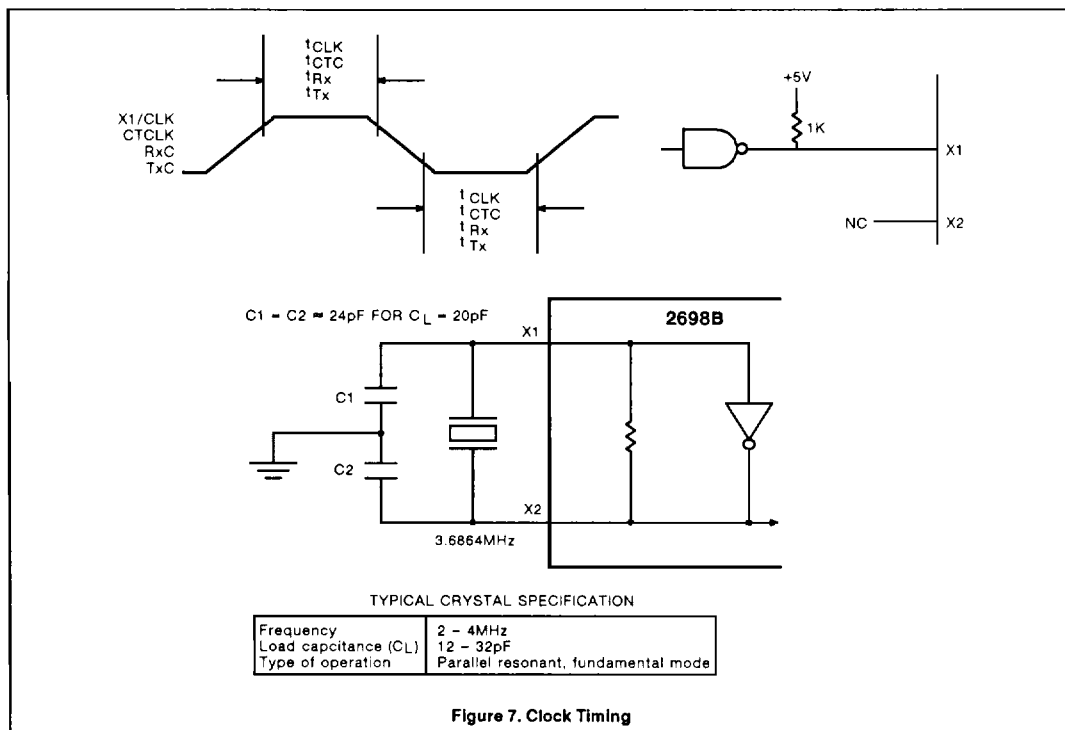

Figure 7. Clock Timing

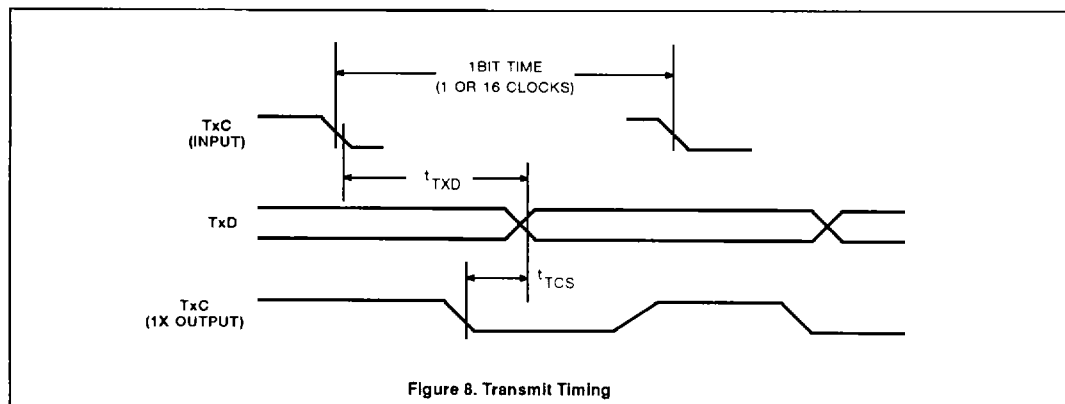

Figure 8. Transmit Timing

Enhanced Octal Universal Asynchronous Receiver/Transmitter

2698B

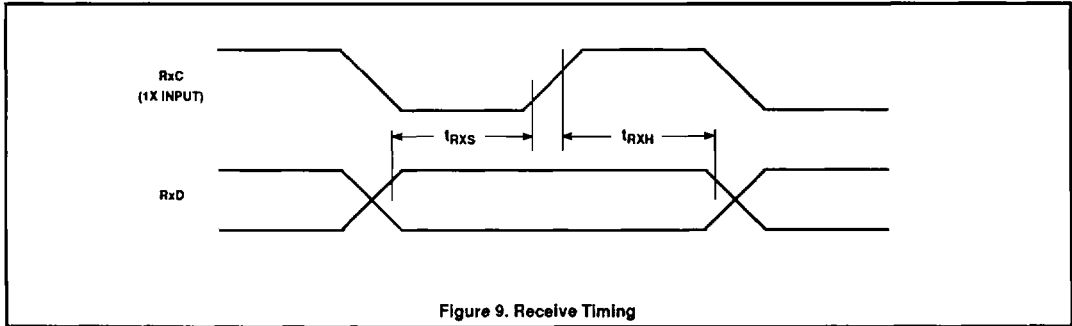

Figure 9. Receive Timing

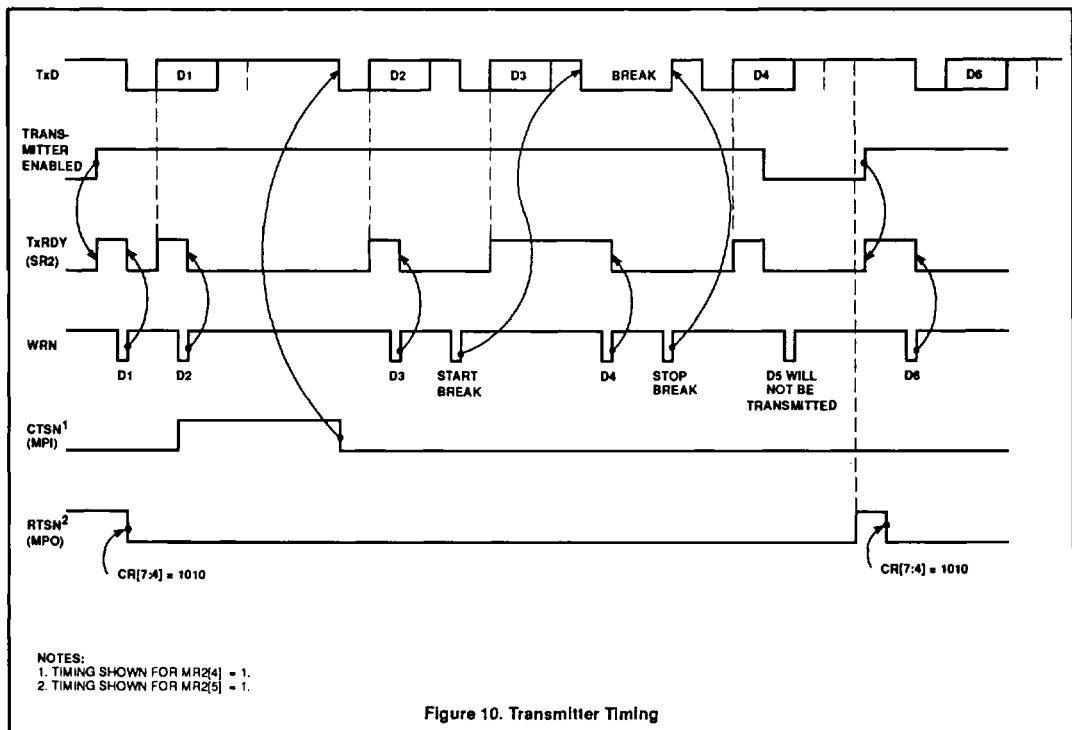

Figure 10. Transmitter Timing

- NOTES:
 1. TIMING SHOWN FOR MR2[4] = 1.
 2. TIMING SHOWN FOR MR2[5] = 1.

Enhanced Octal Universal Asynchronous Receiver/Transmitter

2698B

