

TIL131 THRU TIL133
9-ELEMENT ARRAYS AND 9-CHANNEL PAIR

D1092, SEPTEMBER 1971—REVISED SEPTEMBER 1989

TIL131 . . . 9-ELEMENT GALLIUM ARSENIDE IRED ARRAY *T-41-73*
TIL132 . . . 9-ELEMENT PHOTOTRANSISTOR ARRAY
TIL133 . . . 9-CHANNEL PAIR

- Center-to-Center Spacing of 2,54 mm (0.100 inch) for Tape Reading
- Reliable Solid-State Components
- IREDs Eliminate Lamp-Filament-Sag Problems
- Spectrally Matched for Improved Performance
- Printed Circuit Board Construction Allows Precise Alignment

description

The TIL131 is an array of nine TIL23 gallium arsenide infrared-emitting diodes mounted in a printed circuit board. The TIL132 is an array of nine selected LS600 phototransistors. The TIL133 is a pair of selected arrays comprising a TIL131 and TIL132 and offering specified channel performance.

mechanical data

The printed circuit board material is glass-base NEMA standard FR-4, class II, 0.6-kg/m² (2-oz/ft²) copper-clad on each side. The approximate weight of the TIL131 and TIL132 is 3.7 grams each.

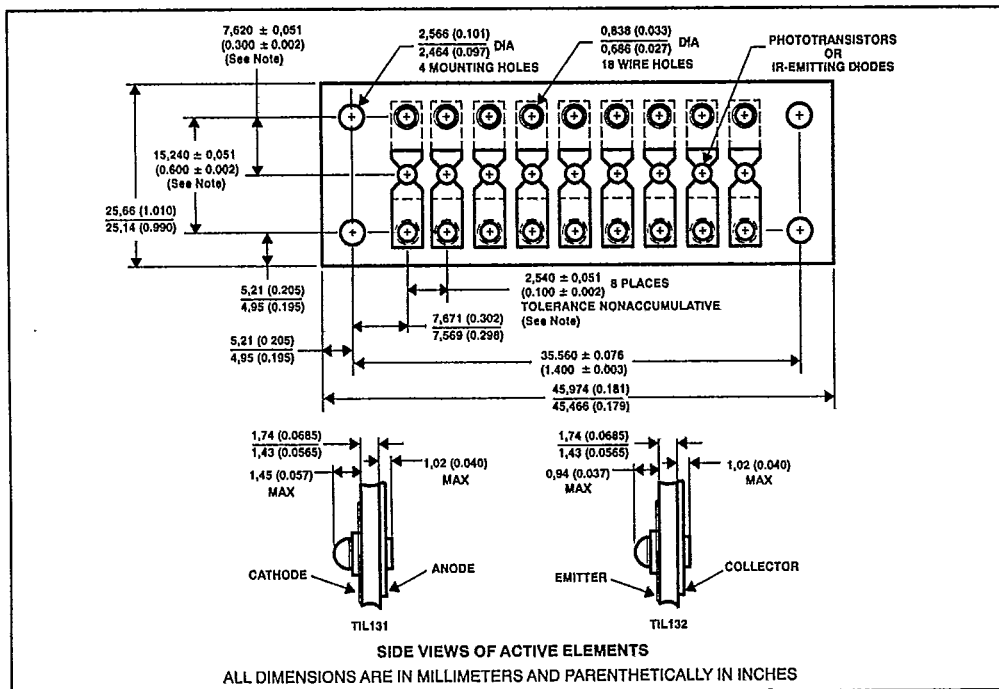

5 Infrared Emitters and Phototransistors

NOTE: The tolerances shown for these dimensions apply to location of the mounting holes and the active elements only. Tolerance of ± 0,13 mm (0.005 inch) applies for location dimensions of the wire holes.

PRODUCTION DATA documents contain information current as of publication date. Products conform to specifications per the terms of Texas Instruments standard warranty. Production processing does not necessarily include testing of all parameters.



Copyright © 1989, Texas Instruments Incorporated

**TIL131 THRU TIL133
9-ELEMENT ARRAYS AND 9-CHANNEL PAIR**

T-41-73

Infrared Emitters and Phototransistors

TIL131 absolute maximum ratings at 25°C free-air temperature (unless otherwise noted)

Reverse voltage	2 V
Continuous forward current at (or below) 25°C free-air temperature (see Note 1)	100 mA
Operating free-air temperature range	-65°C to 125°C
Storage temperature range	-65°C to 150°C
Soldering temperature (10 seconds)	240°C

NOTE 1: Derate linearly to 125°C free-air temperature at the rate of 1 mW/°C.

TIL131 operating characteristics of each element at 25°C free-air temperature range

PARAMETER	TEST CONDITIONS	MIN	TYP	MAX	UNIT
P _O Radiant power output	$I_F = 50 \text{ mA}$	0.4		1	mW
λ_p Wavelength at peak emission			930		nm
$\Delta\lambda$ Spectral bandwidth			50		nm
θ_{HI} Half-intensity beam angle			35°		
V _F Static forward voltage			1.25	1.5	

TIL132 absolute maximum ratings at 25°C free-air temperature (unless otherwise noted)

Collector-emitter voltage	50 V
Emitter-collector voltage	7 V
Continuous device dissipation at (or below) 25°C free-air temperature (see Note 2)	50 mW
Operating free-air temperature range	-65°C to 125°C
Storage temperature range	-65°C to 150°C
Soldering temperature (10 seconds)	240°C

NOTE 2: Derate linearly to 125°C free-air temperature at the rate of 0.5 mW/°C.

TIL132 electrical characteristics at 25°C free-air temperature

individual element characteristics

PARAMETER	TEST CONDITIONS	MIN	TYP	MAX	UNIT
V _{(BR)CEO} Collector-emitter breakdown voltage	I _C = 100 μ A, E _b = 0	50			V
V _{(BR)ECO} Emitter-collector breakdown voltage	I _E = 100 μ A, E _b = 0	7			V
I _D Dark current	V _{CE} = 30 V, E _b = 0			100	nA
I _L Light current	V _{CE} = 5 V, E _b = 20 mW/cm ² , See Note 3	2		12	mA
V _{CE(sat)} Collector-emitter saturation voltage	I _C = 0.4 mA, E _b = 20 mW/cm ² , See Note 3		0.15		V

element matching characteristics

PARAMETER	TEST CONDITIONS	MIN	TYP	MAX	UNIT
$\frac{I_{L \text{ min}}}{I_{L \text{ max}}}$ Light current matching factor	V _{CE} = 5 V, E _b = 20 mW/cm ² , See Note 3	0.5			

NOTE 3: Irradiance (E_b) is the radiant power per unit area incident upon a surface. For this measurement, the source is an unfiltered tungsten linear-filament lamp operating at a color temperature of 2870 K.



TIL131 THRU TIL133
9-ELEMENT ARRAYS AND 9-CHANNEL PAIR

T-41-73

TIL133 absolute maximum ratings at 25°C free-air temperature (unless otherwise noted)

Maximum ratings of TIL131 and TIL132 apply.

TIL133 electrical characteristics at 25°C free-air temperature

PARAMETER	TEST CONDITIONS†	MIN	TYP	MAX	UNIT
I_C Output collector current	$I_F = 50 \text{ mA}$, $V_{CE} = 5 \text{ V}$	2.5	4	10	mA
$V_{CE(sat)}$ Collector-emitter saturation voltage	$I_F = 50 \text{ mA}$, $I_C = 2 \text{ mA}$	0.4	0.7		V

TIL133 switching characteristics at 25°C free-air temperature

PARAMETER	TEST CONDITIONS†	MIN	TYP	MAX	UNIT
t_r Rise time	$V_{CC} = 5 \text{ V}$, $I_{C(on)} = 2 \text{ mA}$		1.5		μs
t_f Fall time	$R_L = 100 \Omega$, See Figure 1		1.5		μs

† These parameters are measured at a lens-to-lens distance of 0.100 inch.

PARAMETER MEASUREMENT INFORMATION

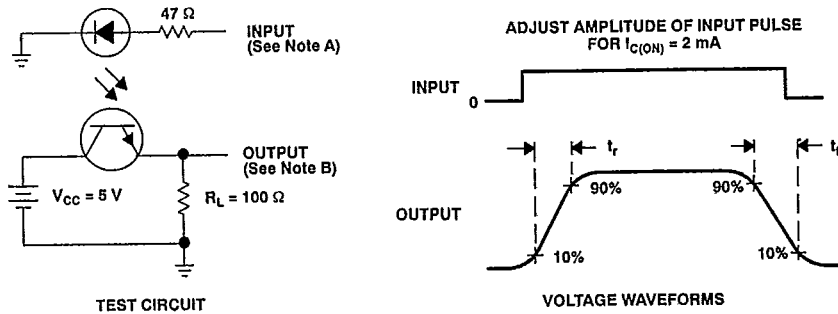

NOTES: A. The input waveform is supplied by a generator with the following characteristics: $Z_{out} = 50 \Omega$, $t_r \leq 15 \text{ ns}$, duty cycle = 1%, $t_w = 100 \mu\text{s}$.
B. The output waveform is monitored on an oscilloscope with the following characteristics: $t_r \leq 12 \text{ ns}$, $R_{in} \geq 1 \text{ M}\Omega$, $C_{in} \leq 20 \text{ pF}$.

FIGURE 1. SWITCHING TIMES

Infrared Emitters and Phototransistors

5

TIL131 THRU TIL133
9-ELEMENT ARRAYS AND 9-CHANNEL PAIR

T-41-73

TYPICAL CHARACTERISTICS

Infrared Emitters and Phototransistors

5

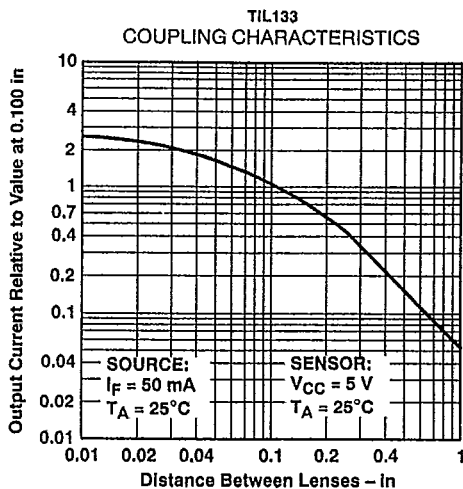

FIGURE 2

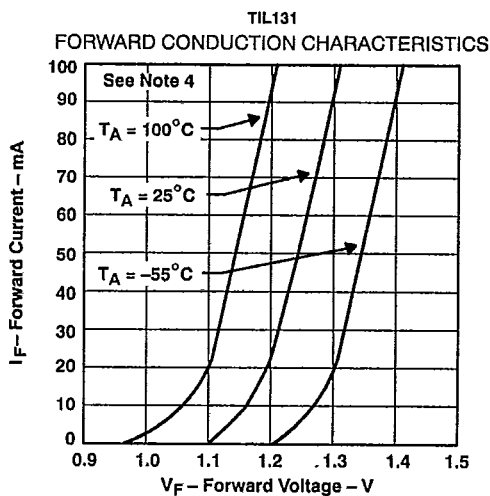

FIGURE 3

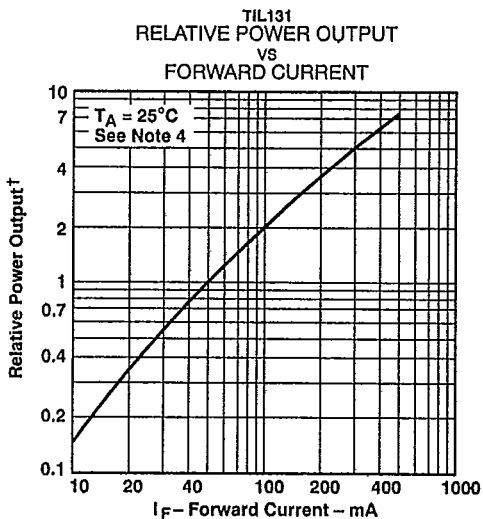

FIGURE 4

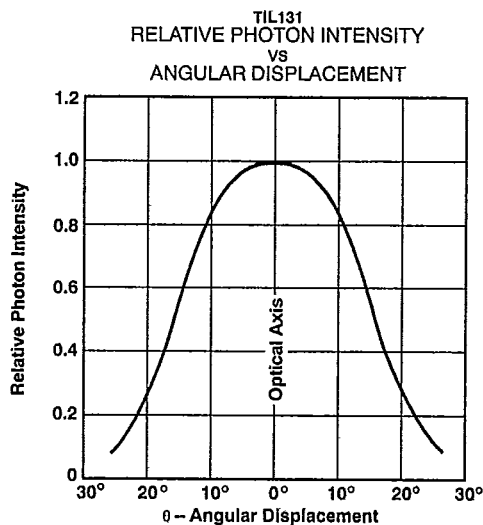

FIGURE 5

† Normalized to output at $I_F = 50$ mA, $T_C = 25^\circ$ C.

NOTE 4: These parameters were measured using pulse techniques: $t_w = 0.04$ ms, duty cycle $\leq 10\%$.

T-41-73

TYPICAL CHARACTERISTICS

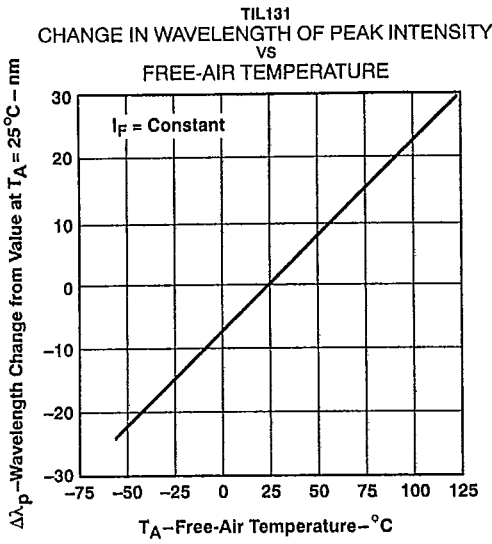

FIGURE 6

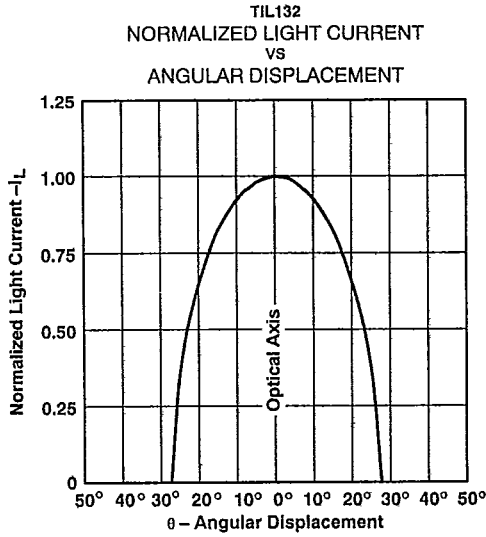

FIGURE 7

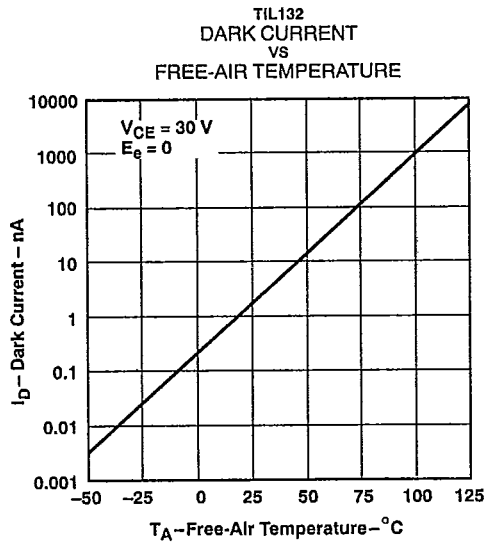

FIGURE 8

Infrared Emitters and Phototransistors

