

STANDARD RECOVERY DIODES
"Lead-Free"

Stud Version

Features

- Diffused glass passivated die
- Standard JEDEC types
- Types up to 600V V_{RRM}
- Stud cathode and stud anode version
- High surge capability
- Very low V_F

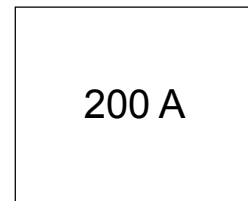

Typical Applications

- Welders
- Power supplies
- Battery chargers

Major Ratings and Characteristics

Parameters	Values	Units
$I_{F(AV)}$	200	A
	@ T_C	125 °C
$I_{F(RMS)}$	314	A
I_{FSM}	@ 50Hz	3570 A
	@ 60Hz	3740 A
I^2t	@ 50Hz	64 KA ² s
	@ 60Hz	58 KA ² s
V_{RRM} range	400 - 600	V
T_J	-40 to 180	°C

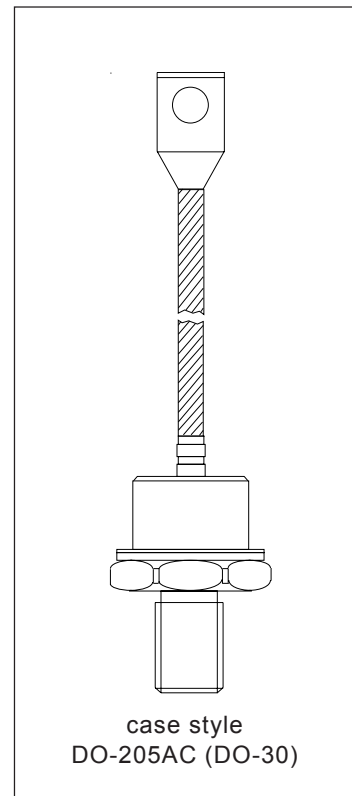

ELECTRICAL SPECIFICATIONS

Voltage Ratings

Type number	Voltage Code	V_{RRM} , maximum repetitive peak reverse voltage V	V_{RSM} , maximum non-repetitive peak rev. voltage V	I_{RRM} max. @ 180°C mA
200HF	40	400	500	10
	60	600	700	

Forward Conduction

Parameter	200HF	Units	Conditions
$I_{F(AV)}$ Max. average forward current @ Case temperature	200	A	180° conduction, half sine wave
	125	°C	
$I_{F(RMS)}$ Max. RMS forward current	314	A	DC @ 115°C case temperature
I_{FSM} Max. peak, one-cycle forward, non-repetitive surge current	3570	A	t = 10ms No voltage
	3740		t = 8.3ms reapplied
	3000		t = 10ms 100% V_{RRM}
	3140		t = 8.3ms reapplied
I^2t Maximum I^2t for fusing	64	KA ² s	t = 10ms No voltage
	58		t = 8.3ms reapplied
	45		t = 10ms 100% V_{RRM}
	41		t = 8.3ms reapplied
$I^2\sqrt{t}$ Maximum $I^2\sqrt{t}$ for fusing	640	KA ² /s	t = 0.1 to 10ms, no voltage reapplied
$V_{F(TO)1}$ Low level value of threshold voltage	0.73	V	$(16.7\% \times \pi \times I_{F(AV)} < I < \pi \times I_{F(AV)})$, $T_J = T_J \text{ max.}$
r_{f1} Low level value of forward	0.48	mΩ	$(16.7\% \times \pi \times I_{F(AV)} < I < \pi \times I_{F(AV)})$, $T_J = T_J \text{ max.}$
V_{FM} Max. forward voltage drop	1.12	V	$I_{pk} = 628A$, $T_J = 25^\circ C$

Thermal and Mechanical Specification

Parameter	200HF	Units	Conditions
T_J Max. operating temperature range	-40 to 180	°C	
T_{stg} Max. storage temperature range	-55 to 180		
R_{thJC} Max. thermal resistance, junction to case	0.25	K/W	DC operation
R_{thCS} Max. thermal resistance, case to heatsink	0.08		Mounting surface, smooth, flat and greased
T Max. allowed mounting torque +0 -20%	11	Nm	Not lubricated threads
	10		Lubricated threads
wt Approximate weight	120	g	
Case style	DO-205AC(DO-30)		See Outline Table

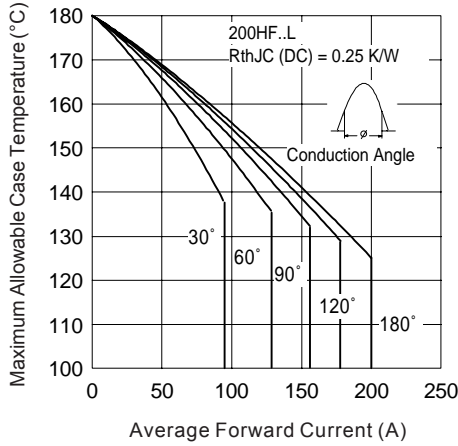

Fig. 1 - Current Ratings Characteristics

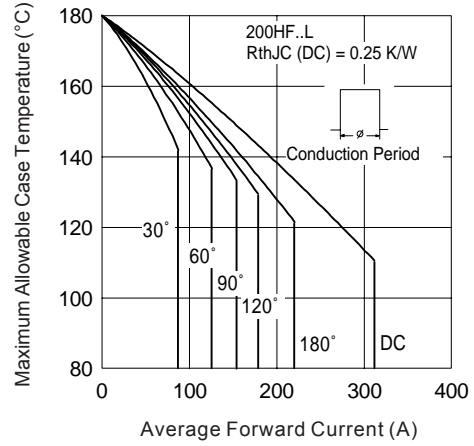

Fig. 2 - Current Ratings Characteristics

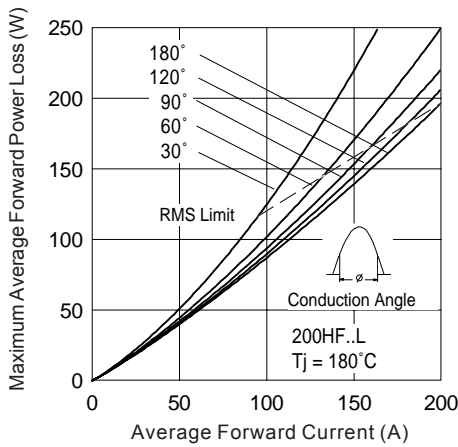

Fig. 3 - Forward Power Loss Characteristics

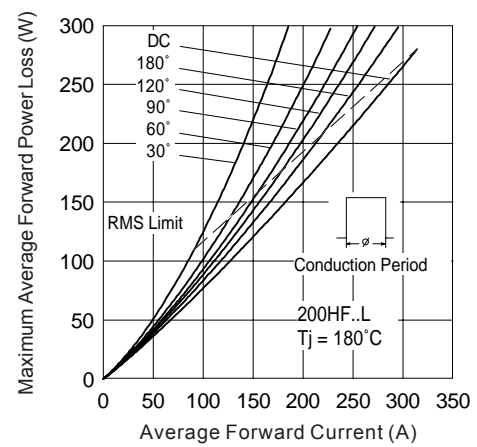

Fig. 4 - Forward Power Loss Characteristics

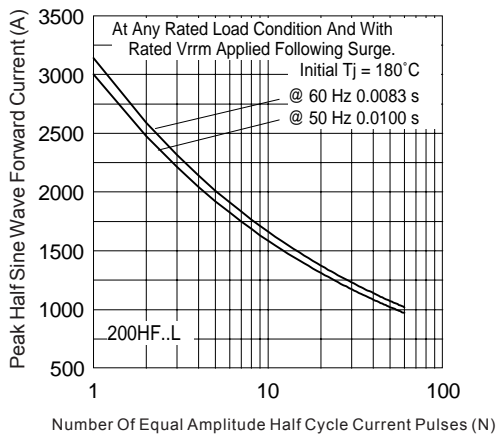

Fig. 5 - Maximum Non-Repetitive Surge Current

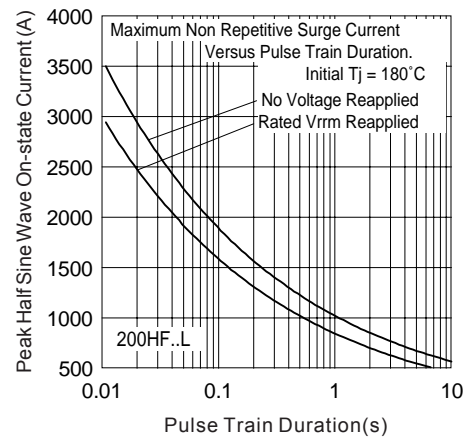

Fig. 6 - Maximum Non-Repetitive Surge Current

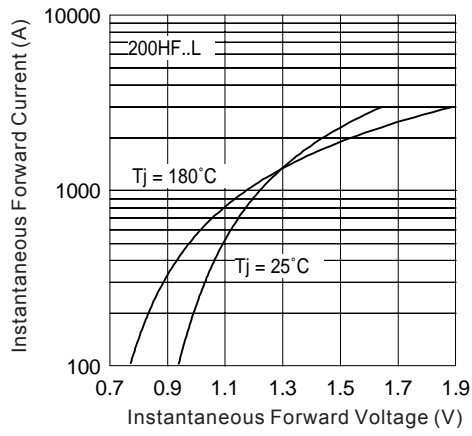

Fig. 7 - Forward Voltage Drop Characteristics

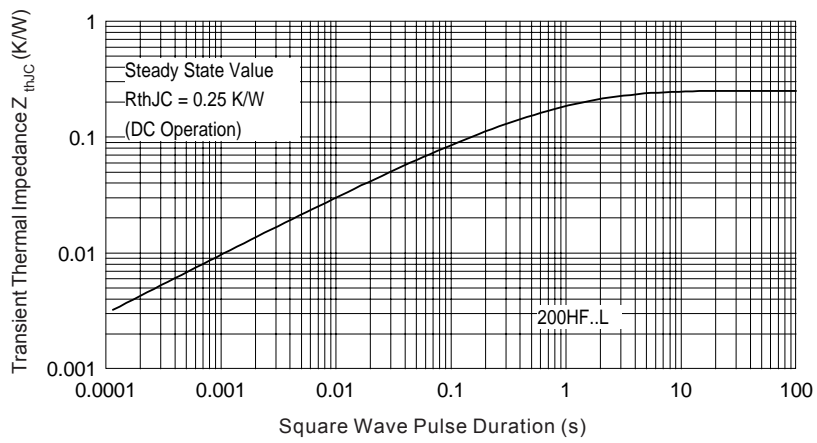
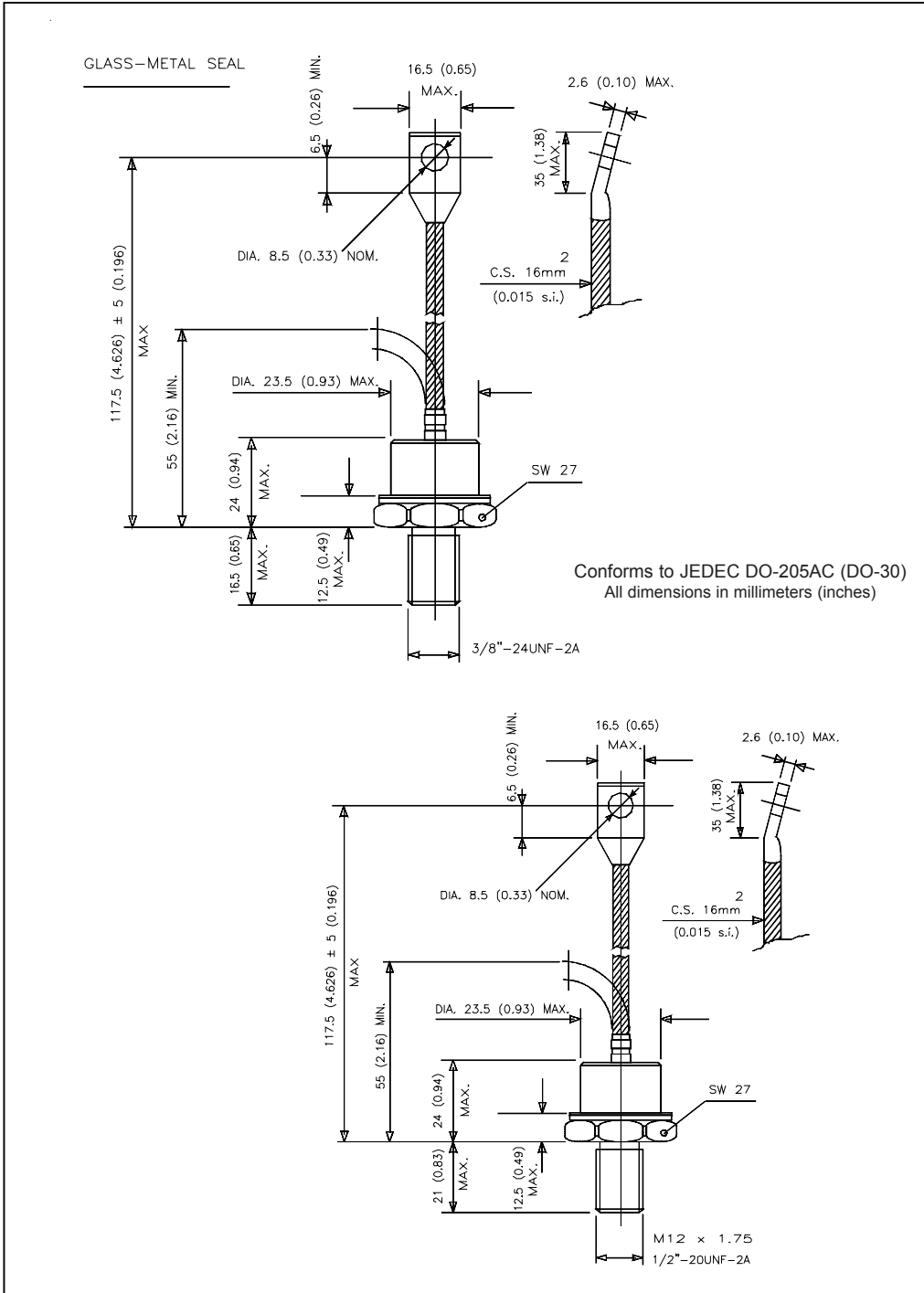

Fig. 8 - Thermal Impedance Z_{thJC} Characteristic

Outlines Table



200HF..L

Bulletin I2041 rev. A 07/05

International
IOR Rectifier

Ordering Information Table

Device Code	
200	HF
40	P
V	L
1	

① ② ③ ④ ⑤ ⑥ ⑦

- 1** - Current Rating (200 = 200A)
- 2** - Diode Diffused
- 3** - Voltage Ratings 40 = 400V
60 = 600V
- 4** -
 - P = 1/2"-20UNF-2A
 - M = Metric M12 x 1.75 (*)
 - W = 3/8"-24UNF-2A
- 5** - Glass-Metal Seal
- 6** - L = Low V_F
- 7** -
 - 1 = Lead 117 mm
 - 2 = Lead 137 mm
 - 3 = Lead 157 mm

(*) For "M" type Contact Factory

Data and specifications subject to change without notice.
This product has been designed and qualified for Industrial Level and Lead-Free.
Qualification Standards can be found on IR's Web site.

International
IOR Rectifier

IR WORLD HEADQUARTERS: 233 Kansas St., El Segundo, California 90245, USA Tel: (310) 252-7105
TAC Fax: (310) 252-7309
Visit us at www.irf.com for sales contact information. 07/05