

Radio On A Chip 2400 MHz Frequency Agile With SPI Bus Interface

Features

- High Level of Integration Minimizes System Cost
- Data Rates over 128.8 Kbits/Sec
- Direct Connection To Microprocessor
- Integrated Antenna Switch
- Adjustable detection bandwidths, data rates
- Adjustable gain, detection level/ hysteresis
- Low and high beta FSK detection modes
- Integrated Manchester coding/decoding
- Programmable Power, Frequency And Tx/Rx/Standby Modes
- Operates From Single 2.5V Power Supply
- Surface Mount Leadless Plastic Packaging

Description

The Honeywell HRF-ROC094XC is a half-duplex transceiver for use in digital data applications. Direct microprocessor connection for control and data transfer, eliminate the need for additional ICs, while integrated data code/decode reduces the instruction set requirements on the microprocessor. The HRF-ROC094XC is ideally suited for use in battery powered wireless applications in conjunction with microprocessors for data communication. Adjustable data rates, filter bandwidths and detection levels allow the IC to be used in a wide variety of high sensitivity / high EMI environments.

Functional Schematic

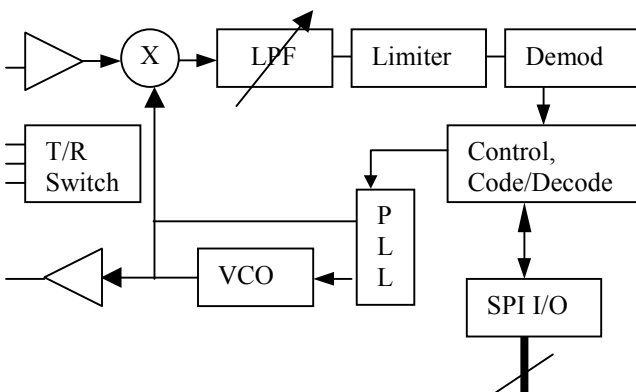

Product Photo

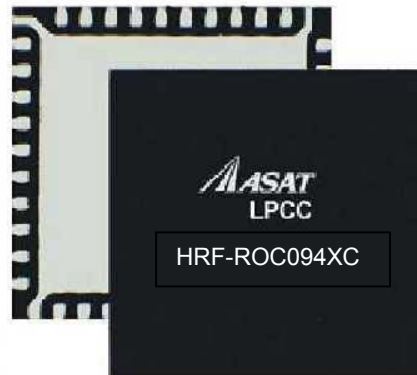

HRF-ROC094XC



Advance Information

RF Electrical Specifications @ + 25°C

Parameter	Test Condition	Frequency	Minimum	Typical	Maximum	Units
Rx Sensitivity		2400-2500 MHz		-95		dBm
1db Compression	Vdd = 2.5V	2400-2500 MHz		-30		dBm
Input IP3	Vdd = 2.5V	2400-2500 MHz		-15		dBm
Tx Output Power	Vdd = 2.5V	2400-2500 MHz		+3		dBm
Data Rate, Tx / Rx	Continuous PacketizedData			128		Kbps
Channel Rejection	Adjacent Channels	Fc +/- 350KHz		60		dB
Max Detection BW*	IQ Baseband Filter Passband			250		KHz
Control/Data I/O	Serial Peripheral Interface (SPI). Direct Connection To Micro controller/Microprocessor			10		MHz

* Bandwidth reduction possible using off chip elements

DC Electrical Specifications @ + 25°C

Parameter	Minimum	Typical	Maximum	Units
V _{DD} Power Supply Voltage	2.4	2.5	2.6	V
Power Supply Current During Tx, Output Power Dependant (2450 MHz)	16	26		mA
Power Supply Current (I _{DD}) During Rx (2450MHz)	22	28		mA
Standby Current Consumption		<1		uA
CMOS Logic Level (0)	0		0.7	V
CMOS Logic Level (1)	1.7		V _{DD}	V
Input Leakage Current			2	nA

Absolute Maximum Ratings¹

Parameter	Absolute Maximum	Units
Maximum Input Power	-	-
V _{DD}	+ 2.8	V
ESD Voltage (Human Body Model)	200	V
Operating Temperature	- 40 to + 85	Degrees C
Storage Temperature	- 40 to + 150	Degrees C

(Note 1) Operation Of The HRF-ROC094XC Beyond Any Of These Parameters May Cause Permanent Damage.

ESD Protection: The HRF-ROC094XC Contains reduced ESD Protection Circuitry for sensitive RF I/O. Precautions Should Be Taken During Handling/Assembly Until Protected By External Circuitry or Housings

HRF-ROC094XC

Typical Application

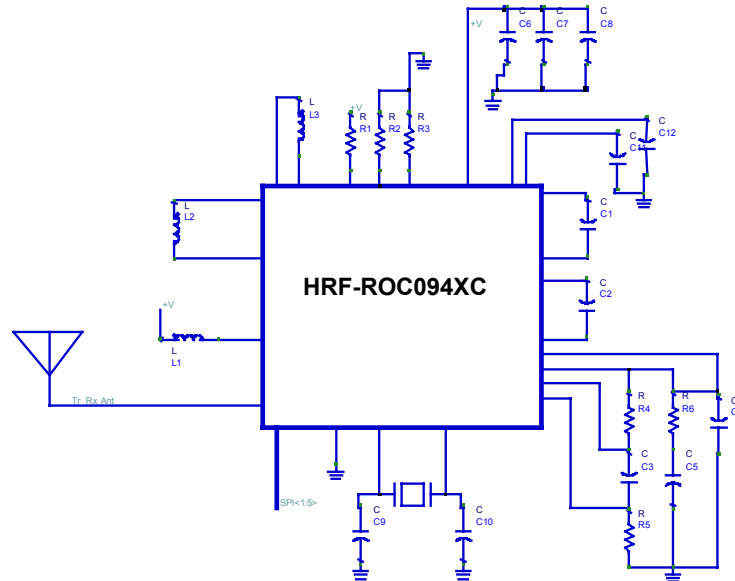

Package Outline

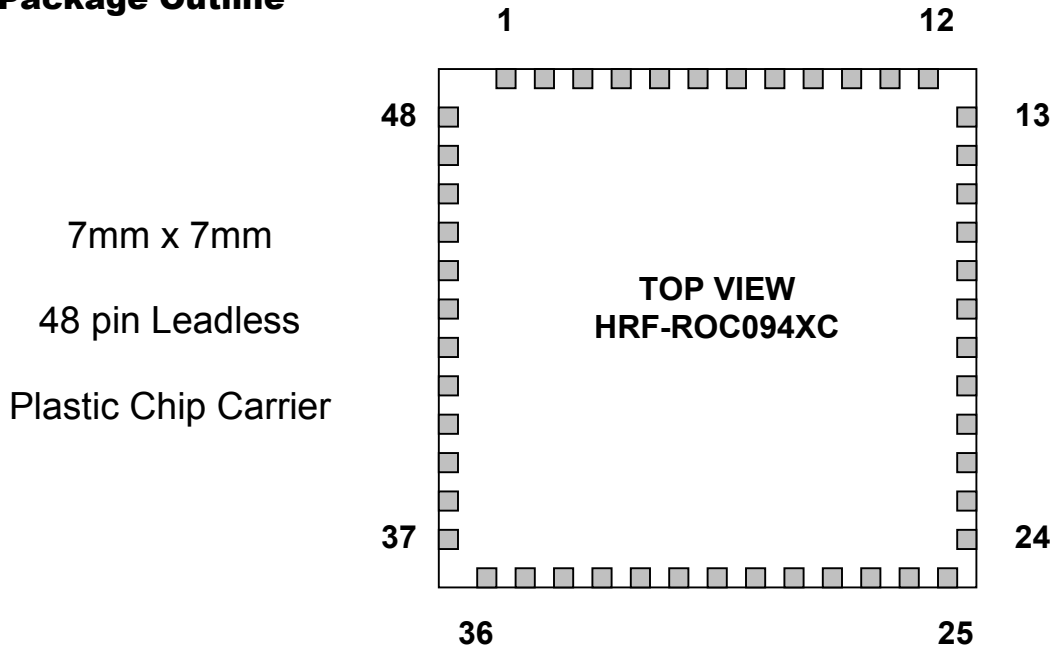

Low inductance RF/DC ground connection required below part as bottom ground pad is used for all device grounding. Additionally, this connection provides a direct connection to the die for enhanced thermal dissipation. **Package shown not to scale.**

HRF-ROC094XC



Advance Information

Pin Configuration

HRF-ROC094XC 48 Pin LPCC™ (7 mm X 7 mm) Package Pin List

* RF/Digital ground is provided through backside slug pad.

Name	Pin #	Function	Name	Pin #	Function
Sw_Ant	1	Antenna connection	SPI_data_out	25	SPI serial data output
Switch Rx	2	T/R switch RX output (tie to LNA Input)	SPI_INT_out	26	SPI interrupt output
LNA Bias R	3	Bias resistor for LNA : ~ 16K	Tx_data_v	27	CMOS fifo monitor for board debug
LNA Input	4	LNA input / LNA Match	Rx_out_p	28	Async data output buffered, polarity selected for board debug
Digital gain desense	5	Low is high gain, High is low gain	Vp	29	Digital positive supply
Vp	6	LNA positive supply	Vp	30	Digital positive supply
Vp	7	LNA positive supply	Hysterisis A	31	4 level, 2 bit digital control of detection level hysteresis
Vp	8	Mixer positive supply	Hysterisis B	32	“ “
I mixer bias adj	9	Senitivity/IP3 tradeoff	P_test_out	33	PLL N-counter output comp freq
Q mix bias adj	10	“ “	R_test_out	34	PLL R-counter output comp freq
I filter bw	11	bw reduction adjustment	Crystal 1	35	Reference crystal connection
I filter bw	12	“ ”	Crystal 2	36	Reference crystal connection
Q filter bw	13	“ ”	Pdout	37	Phase detector charge pump output
Q filter bw	14	“ ”	Rext_PLL	38	PLL bias resistor
Vp	15	Analog electronics supply	Vp	39	Phase detector power supply
Supply filter	16	Common mode voltage bypass	Tx_mod data	40	Mod charge pump output
Raw data	17	Raw detected data / predetect data shaping	Vmod1	41	High deviation varactor input
Detection trig lev	18	Monitor/filtering of ref level	Vmod2	42	Low deviation varactor input
Mixer ref	19	Baseband ref voltage bypass	VCO_state	43	Pull up to Vp
Resetrn	20	Dig power-on reset	VP	44	VCO positive supply
SPI_data_in	21	SPI serial data input	PA_out	45	PA output pin direct coupled
Dig_data_in	22	Dig FIFO RX data, bypass RX demod	Vp	46	PA positive supply
SPI_SSN_in	23	SPI slave select	PA_out_ac	47	PA connection, AC coupled
SPI_CLK_in	24	SPI Clock Input	Sw_TX	48	T/R switch PA input (tie to PA_out_ac)

Web Site: www.mysoiservices.com
 Email: mysoiservices@honeywell.com

2002 09425XC Published June 2002 Page 4

Honeywell
 Solid State Electronics Center
 12001 State Highway 55
 Plymouth, Minnesota 55441-4799
 1-800-323-8295

HRF-ROC094XC



Advance Information

Engineering Evaluation Board

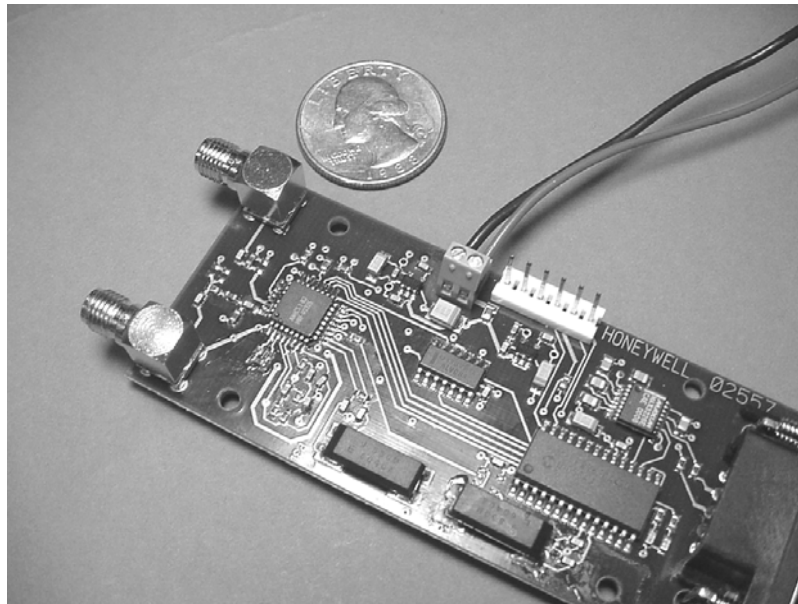

The engineering evaluation board provides for a RS232 connection using a PIC microcontroller as the interface between the HRF-ROC094XC and the RS232 port. Using the software provided and a PC, control of test data, operating frequency, power levels and all internal registers is available for early product development/prototyping. The board operates from a single +6 to +9 volt supply and provides separate RF Rx/Tx ports.

Ordering Information

Ordering Number	Product
HRF-ROC094XC -B	Delivered In Chip Tubes
HRF-ROC094XC -T	Delivered On Tape And Reel ²
HRF-ROC094XC -E	Engineering Evaluation Board

Note 2: Contact Honeywell for details

Honeywell reserves the right to make changes to improve reliability, function or design. Honeywell does not assume any liability arising out of the application or use of any product or circuit described herein; neither does it convey any license under its patent rights nor the rights of others.

Web Site: www.mysoiservices.com
Email: mysoiservices@honeywell.com

2002 09425XC Published June 2002 Page 5

Honeywell
Solid State Electronics Center
12001 State Highway 55
Plymouth, Minnesota 55441-4799
1-800-323-8295