

**DUAL OP AMP AND VOLTAGE REFERENCE****AP4301****General Description**

The AP4301 is a monolithic IC specifically designed to regulate the output current and voltage levels of switching battery chargers and power supplies.

The device contains two operational amplifiers and a precision shunt regulator. Op Amp 1 is designed for voltage control, whose non-inverting input internally connects to the output of the shunt regulator. Op Amp 2 is for current control with both inputs uncommitted. The IC offers the power converter designer a control solution that features increased precision with a corresponding reduction in system complexity and cost.

The AP4301 is available in standard packages of DIP-8 and SOIC-8.

**Features****Op Amp**

- Input Offset Voltage: 0.5mV
- Supply Current: 250 $\mu$ A per Op-Amp at 5.0V Supply Voltage
- Unity Gain Bandwidth: 1MHz
- Output Voltage Swing: 0 to ( $V_{CC}-1.5$ )V
- Power Supply Range: 3 to 18V

**Voltage Reference**

- Fixed Output Voltage Reference: 1.25V, 1.24V
- Voltage Tolerance: 0.5%, 1%
- Sink Current Capability from 0.1 to 80mA

**Applications**

- Battery Charger
- Switching Power Supply

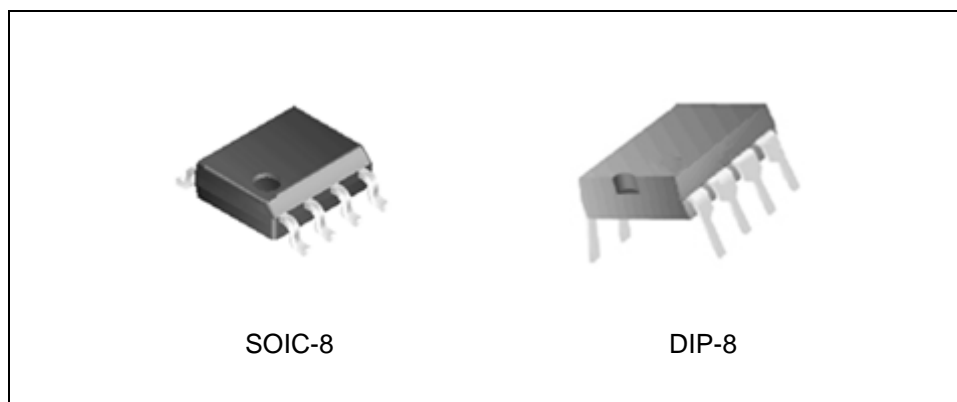

Figure 1. Package Types of AP4301



**DUAL OP AMP AND VOLTAGE REFERENCE**

**AP4301**

**Pin Configuration**

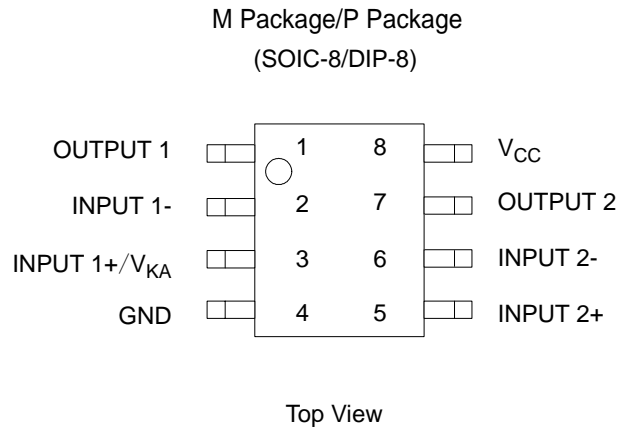

Figure 2. Pin Configuration of AP4301

**Functional Block Diagram**

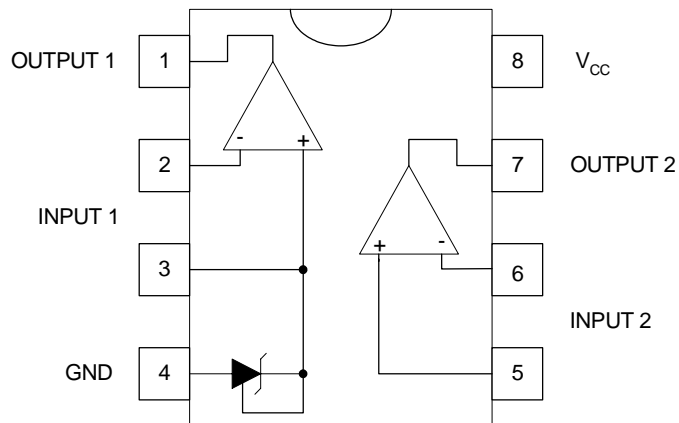

Figure 3. Functional Block Diagram of AP4301



**DUAL OP AMP AND VOLTAGE REFERENCE**

**AP4301**

**Functional Block Diagram (Continued)**

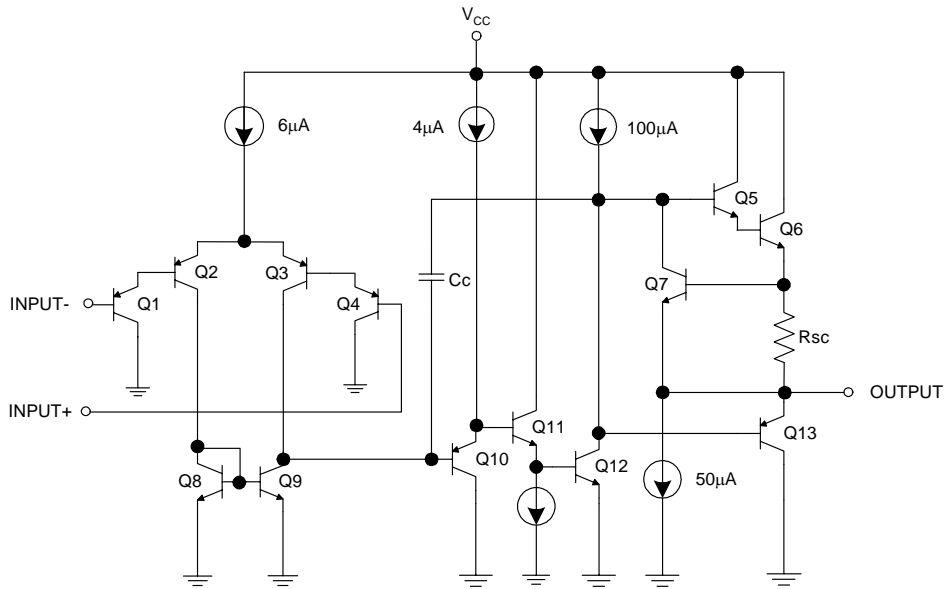

Figure 4. Op Amp Functional Block Diagram  
(Each Amplifier)

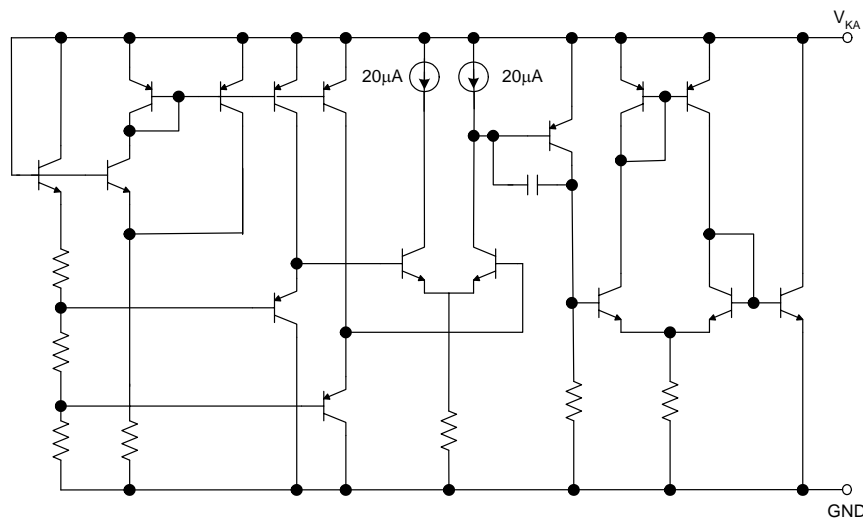

Figure 5. Voltage Reference Functional Block Diagram



**DUAL OP AMP AND VOLTAGE REFERENCE**

**AP4301**

**Ordering Information**

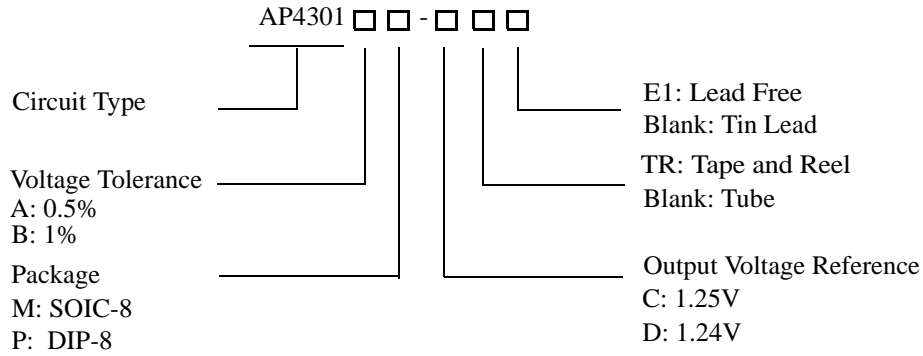

Package	Reference Voltage	Voltage Tolerance	Temperature Range	Part Number		Marking ID		Packing Type
				Tin Lead	Lead Free	Tin Lead	Lead Free	
DIP-8	1.25V	0.5%	-40 to 85°C	AP4301AP-C	AP4301AP-CE1	AP4301AP-C	AP4301AP-CE1	Tube
		1%		AP4301BP-C	AP4301BP-CE1	AP4301BP-C	AP4301BP-CE1	
	1.24V	0.5%		AP4301AP-D	AP4301AP-DE1	AP4301AP-D	AP4301AP-DE1	
		1%		AP4301BP-D	AP4301BP-DE1	AP4301BP-D	AP4301BP-DE1	
SOIC-8	1.25V	0.5%	-40 to 85°C	AP4301AM-C	AP4301AM-CE1	AP4301AM-C	AP4301AM-CE1	Tube
				AP4301AM-CTR	AP4301AM-CTRE1	AP4301AM-C	AP4301AM-CE1	Tape & Reel
		1%		AP4301BM-C	AP4301BM-CE1	AP4301BM-C	AP4301BM-CE1	Tube
				AP4301BM-CTR	AP4301BM-CTRE1	AP4301BM-C	AP4301BM-CE1	Tape & Reel
	1.24V	0.5%		AP4301AM-D	AP4301AM-DE1	AP4301AM-D	AP4301AM-DE1	Tube
				AP4301AM-DTR	AP4301AM-DTRE1	AP4301AM-D	AP4301AM-DE1	Tape & Reel
		1%		AP4301BM-D	AP4301BM-DE1	AP4301BM-D	AP4301BM-DE1	Tube
				AP4301BM-DTR	AP4301BM-DTRE1	AP4301BM-D	AP4301BM-DE1	Tape/ Reel

BCD Semiconductor's Pb-free products, as designated with "E1" suffix in the part number, are RoHS compliant.

**DUAL OP AMP AND VOLTAGE REFERENCE****AP4301****Absolute Maximum Ratings (Note 1)**

Parameter	Symbol	Value	Unit
Power Supply Voltage ( $V_{CC}$ to GND)	$V_{CC}$	20	V
Op Amp 1 and 2 Input Voltage Range (Pins 2, 5, 6)	$V_{IN}$	-0.3 to $V_{CC}+0.3$	V
Op Amp 2 Input Differential Voltage (Pins 5, 6)	$V_{ID}$	20	V
Voltage Reference Cathode Current (Pin 3)	$I_K$	100	mA
Power Dissipation	$P_D$	DIP-8	800
		SOIC-8	500
Operating Junction Temperature	$T_J$	150	$^{\circ}\text{C}$
Storage Temperature Range	$T_{STG}$	-65 to 150	$^{\circ}\text{C}$
Lead Temperature (Soldering 10s)	$T_L$	260	$^{\circ}\text{C}$

Note 1: Stresses greater than those listed under "Absolute Maximum Ratings" may cause permanent damage to the device. These are stress ratings only, and functional operation of the device at these or any other conditions beyond those indicated under "Recommended Operating Conditions" is not implied. Exposure to "Absolute Maximum Ratings" for extended periods may affect device reliability.

**Recommended Operating Conditions**

Parameter	Min	Max	Unit
Supply Voltage	3	18	V
Ambient Temperature	-40	85	$^{\circ}\text{C}$



**DUAL OP AMP AND VOLTAGE REFERENCE**

**AP4301**

**Electrical Characteristics**

Operating Conditions:  $V_{CC}=+5V$ ,  $T_A=25^{\circ}C$  unless otherwise specified.

Parameter	Conditions		Min	Typ	Max	Unit
Total Supply Current, Excluding Current in Voltage Reference	$V_{CC}=5V$ , no load, $-40^{\circ}C \leq T_A \leq 85^{\circ}C$			0.5	0.8	mA
	$V_{CC}=18V$ , no load, $-40^{\circ}C \leq T_A \leq 85^{\circ}C$			0.6	1.2	
<b>Voltage Reference Section</b>						
Reference Voltage for AP4301-C	$I_K=10mA$ $T_A=25^{\circ}C$	0.5% tolerance	1.244	1.250	1.256	V
		1% tolerance	1.237		1.263	
Reference Voltage for AP4301-D	$I_K=10mA$ $T_A=25^{\circ}C$	0.5% tolerance	1.234	1.240	1.246	V
		1% tolerance	1.227		1.252	
Reference Voltage Deviation over Full Temperature Range	$I_K=10mA$ , $T_A=-40$ to $85^{\circ}C$			5	17	mV
Minimum Cathode Current for Regulation				0.2	1	mA
Dynamic Impedance	$I_K=1.0$ to $80mA$ , $f < 1kHz$			0.2	0.5	$\Omega$
<b>Op Amp 1 Section (<math>V_{CC}=5V</math>, <math>V_O=1.4V</math>, <math>T_A=25^{\circ}C</math>, unless otherwise noted)</b>						
Input Offset Voltage	$T_A=25^{\circ}C$			0.5	3	mV
	$T_A=-40$ to $85^{\circ}C$				5	
Input Offset Voltage Temperature Drift	$T_A=-40$ to $85^{\circ}C$			7		$\mu V/^{\circ}C$
Input Bias Current (Inverting Input Only)	$T_A=25^{\circ}C$			20	150	nA
Large Signal Voltage Gain	$V_{CC}=15V$ , $R_L=2k\Omega$ , $V_O=1.4$ to $11.4V$		85	100		dB
Power Supply Rejection Ratio	$V_{CC}=5$ to $18V$		70	90		dB
Output Current	Source	$V_{CC}=15V$ , $V_{ID}=1V$ , $V_O=2V$	20	40		mA
	Sink	$V_{CC}=15V$ , $V_{ID}=-1V$ , $V_O=2V$	10	20		mA
Output Voltage Swing (High)	$V_{CC}=18V$ , $R_L=10k\Omega$ , $V_{ID}=1V$		16	16.5		V
Output Voltage Swing (Low)	$V_{CC}=18V$ , $R_L=10k\Omega$ , $V_{ID}=-1V$			17	100	mV
Slew Rate	$V_{CC}=18V$ , $R_L=2k\Omega$ , $A_V=1$ , $V_{IN}=0.5$ to $2V$ , $C_L=100pF$		0.2	0.5		$V/\mu s$
Gain Bandwidth Product	$V_{CC}=18V$ , $R_L=2k\Omega$ , $C_L=100pF$ , $V_{IN}=10mV$ , $f=100kHz$		0.7	1		MHz



**DUAL OP AMP AND VOLTAGE REFERENCE**

**AP4301**

**Electrical Characteristics (Continued)**

Operating Conditions:  $V_{CC}=+5V$ ,  $T_A=25^{\circ}C$  unless otherwise specified.

Parameter	Conditions	Min	Typ	Max	Unit
<b>Op Amp2 Section (<math>V_{CC}=5V</math>, <math>V_O=1.4V</math>, <math>T_A=25^{\circ}C</math>, unless otherwise noted)</b>					
Input Offset Voltage	$T_A=25^{\circ}C$		0.5	3	mV
	$T_A=-40$ to $85^{\circ}C$			5	
Input Offset Voltage Temperature Drift	$T_A=-40$ to $85^{\circ}C$		7		$\mu V/^{\circ}C$
Input Offset Current	$T_A=25^{\circ}C$		2	30	nA
Input Bias Current	$T_A=25^{\circ}C$		20	150	nA
Input Voltage Range	$V_{CC}=0$ to $18V$	0		$V_{CC}-1.5$	V
Common Mode Rejection Ratio	$T_A=25^{\circ}C$ , $V_{CM}=0$ to $3.5V$	70	85		dB
Large Signal Voltage Gain	$V_{CC}=15V$ , $R_L=2k\Omega$ , $V_O=1.4$ to $11.4V$	85	100		dB
Power Supply Rejection Ratio	$V_{CC}=5$ to $18V$	70	90		dB
Output Current	Source $V_{CC}=15V$ , $V_{ID}=1V$ , $V_O=2V$	20	40		mA
	Sink $V_{CC}=15V$ , $V_{ID}=-1V$ , $V_O=2V$	10	20		mA
Output Voltage Swing (High)	$V_{CC}=18V$ , $R_L=10k\Omega$ , $V_{ID}=1V$	16	16.5		V
Output Voltage SWing (Low)	$V_{CC}=18V$ , $R_L=10k\Omega$ , $V_{ID}=-1V$		17	100	mV
Slew Rate	$V_{CC}=18V$ , $R_L=2k\Omega$ , $A_V=1$ , $V_{IN}=0.5$ to $2V$ , $C_L=100pF$	0.2	0.5		$V/\mu s$
Gain Bandwidth Product	$V_{CC}=18V$ , $R_L=2k\Omega$ , $C_L=100pF$ , $V_{IN}=10mV$ , $f=100kHz$	0.7	1		MHz



**DUAL OP AMP AND VOLTAGE REFERENCE**

**AP4301**

**Typical Performance Characteristics**

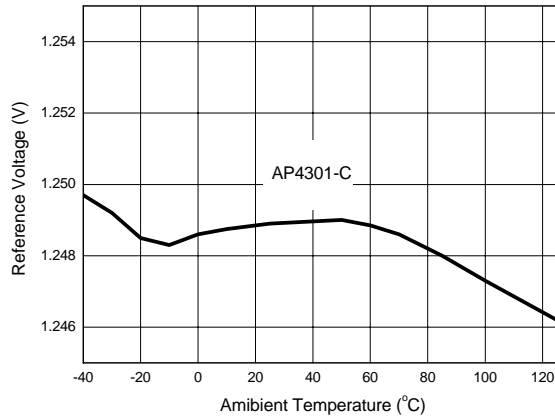

Figure 6. Reference Voltage vs. Ambient Temperature

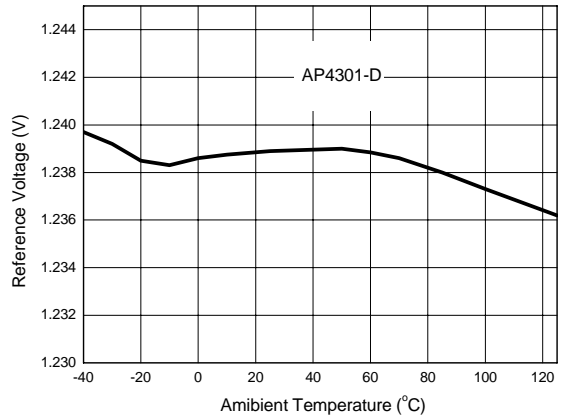

Figure 7. Reference Voltage vs. Ambient Temperature

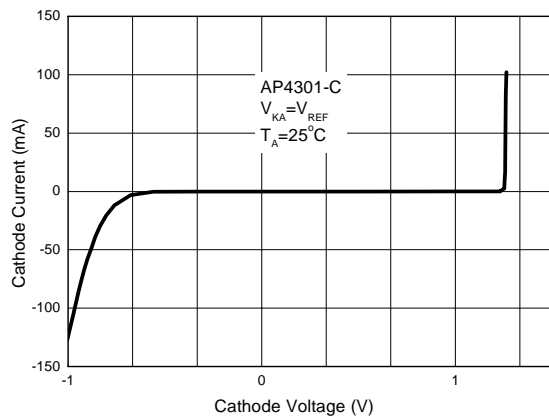

Figure 8. Cathode Current vs. Cathode Voltage

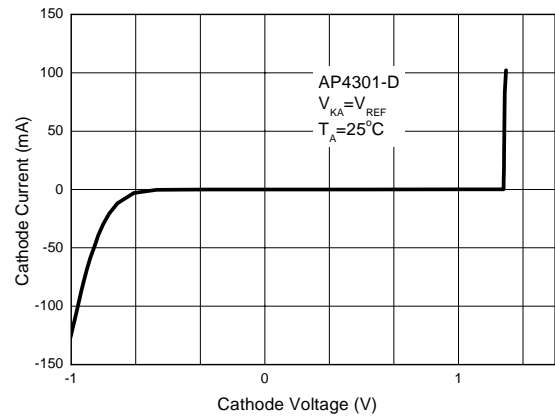

Figure 9. Cathode Current vs. Cathode Voltage



**DUAL OP AMP AND VOLTAGE REFERENCE**

**AP4301**

**Typical Performance Characteristics (Continued)**

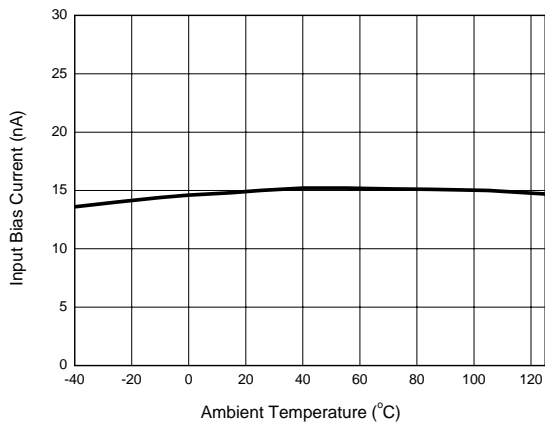

Figure 10. Input Bias Current vs. Ambient Temperature

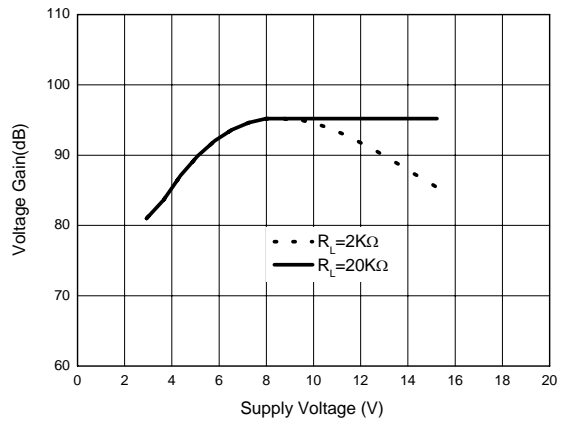

Figure 11. Op Amp Voltage Gain



**DUAL OP AMP AND VOLTAGE REFERENCE**

**AP4301**

**Typical Application**

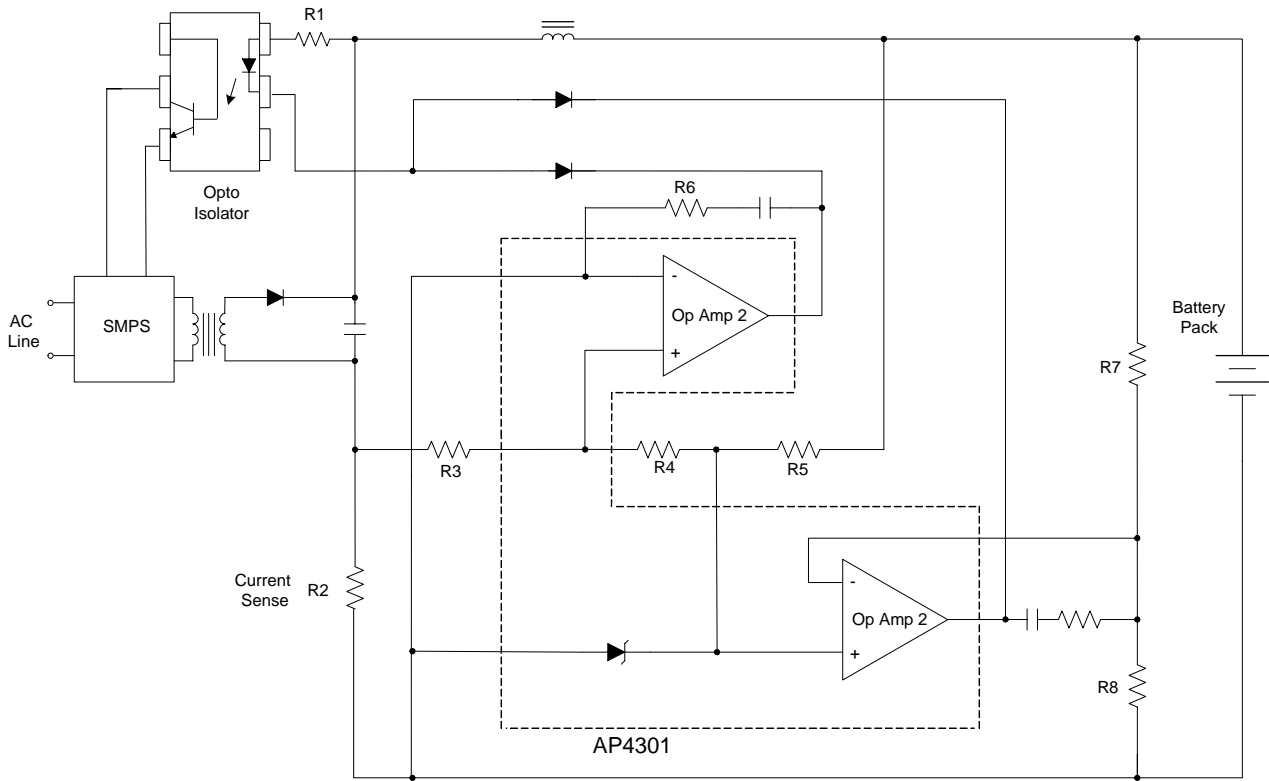

Figure 12. Application of AP4301 in a Constant Current and Constant Voltage Charger



**DUAL OP AMP AND VOLTAGE REFERENCE**

**AP4301**

**Mechanical Dimensions**

**DIP-8**

**Unit: mm(inch)**

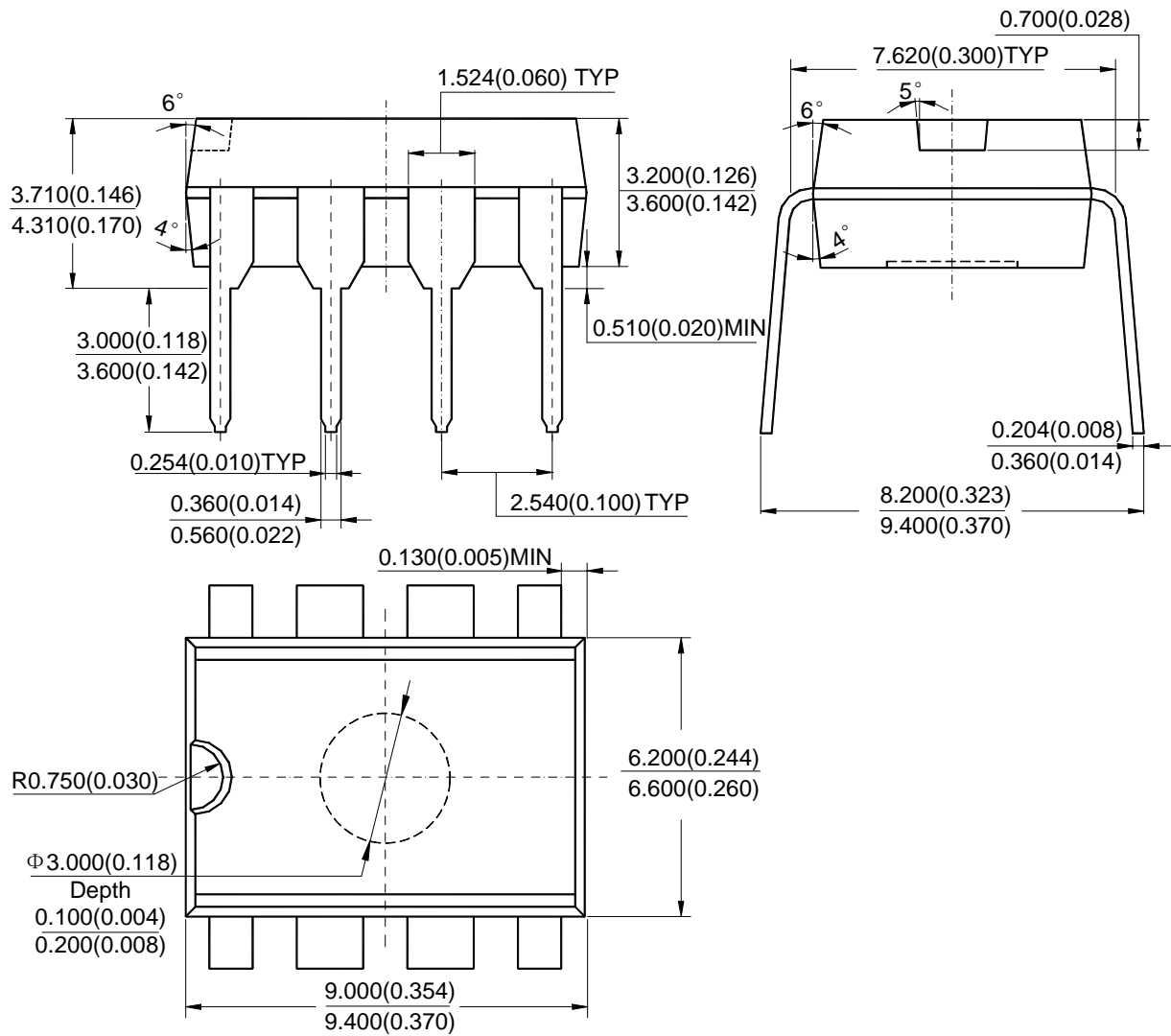





## **BCD Semiconductor Manufacturing Limited**

<http://www.bcdsemi.com>

### **IMPORTANT NOTICE**

BCD Semiconductor Manufacturing Limited reserves the right to make changes without further notice to any products or specifications herein. BCD Semiconductor Manufacturing Limited does not assume any responsibility for use of any its products for any particular purpose, nor does BCD Semiconductor Manufacturing Limited assume any liability arising out of the application or use of any its products or circuits. BCD Semiconductor Manufacturing Limited does not convey any license under its patent rights or other rights nor the rights of others.

---

#### **MAIN SITE**

**BCD Semiconductor Manufacturing Limited**  
- Wafer Fab  
**Shanghai SIM-BCD Semiconductor Manufacturing Limited**  
800, Yi Shan Road, Shanghai 200233, China  
Tel: +86-21-6485 1491, Fax: +86-21-5450 0008

**BCD Semiconductor Manufacturing Limited**  
- IC Design Group  
**Advanced Analog Circuits (Shanghai) Corporation**  
8F, Zone B, 900, Yi Shan Road, Shanghai 200233, China  
Tel: +86-21-6495 9539, Fax: +86-21-6485 9673

#### **REGIONAL SALES OFFICE**

**Shenzhen Office**  
**Shanghai SIM-BCD Semiconductor Manufacturing Co., Ltd. Shenzhen Office**  
**Advanced Analog Circuits (Shanghai) Corporation Shenzhen Office**  
Room E, 5F, Noble Center, No.1006, 3rd Fuzhong Road, Futian District, Shenzhen 518026, China  
Tel: +86-755-8826 7951  
Fax: +86-755-8826 7865

**Taiwan Office**  
**BCD Semiconductor (Taiwan) Company Limited**  
4F, 298-1, Rui Guang Road, Nei-Hu District, Taipei, Taiwan  
Tel: +886-2-2656 2808  
Fax: +886-2-2656 2806

**USA Office**  
**BCD Semiconductor Corporation**  
30920 Huntwood Ave. Hayward, CA 94544, U.S.A  
Tel : +1-510-324-2988  
Fax: +1-510-324-2788