

**FEATURES**

- 300ps typical propagation delay
- <100ps typical output-to-output skew
- Differential PECL outputs
- PNP TTL inputs for minimal loading
- Flow-through pinouts
- ESD protection of 2000V
- Available in 8-pin SOIC package

**DESCRIPTION**

The SY10/100ELT22L are dual TTL-to-differential PECL translators with +3.3V power supply. Because PECL (Positive ECL) levels are used, only +3.3V and ground are required. The small outline 8-lead SOIC package and the low skew, dual gate design of the ELT22L makes it ideal for applications which require the translation of a clock and a data signal.

The ELT22L is available in both ECL standards: the 10ELT is compatible with positive ECL 10H logic levels, while the 100ELT is compatible with positive ECL 100K logic levels.

**PIN CONFIGURATION/BLOCK DIAGRAM**

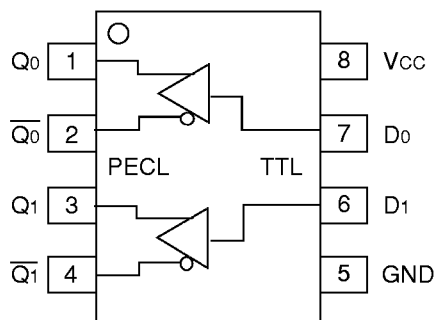

SOIC  
TOP VIEW

**PIN NAMES**

Pin	Function
Q <sub>n</sub>	Differential PECL Outputs
D <sub>n</sub>	TTL Inputs
V <sub>CC</sub>	+3.3V Supply
GND	Ground

**ABSOLUTE MAXIMUM RATINGS<sup>(1)</sup>**

Symbol	Parameter	Value	Unit
V <sub>CC</sub>	Power Supply Voltage	-0.5 to +7.0	V
V <sub>I</sub>	TTL Input Voltage	-0.5 to V <sub>CC</sub>	V
I <sub>OUT</sub>	PECL Output Current — Continuous — Surge	50 100	mA
T <sub>store</sub>	Storage Temperature	-65 to +150	°C
T <sub>amb</sub>	Operating Temperature	-40 to +85	°C

**TRUTH TABLE**

D	Q	$\bar{Q}$
H	H	L
L	L	H
Open	H	L

**NOTES:**

- Permanent device damage may occur if ABSOLUTE MAXIMUM RATINGS are exceeded. This is a stress rating only and functional operation is not implied at conditions other than those detailed in the operational sections of this data sheet. Exposure to ABSOLUTE MAXIMUM RATING conditions for extended periods may affect device reliability.

**DC ELECTRICAL CHARACTERISTICS<sup>(1)</sup>**

 V<sub>CC</sub> = +3.0V to +3.8V

Symbol	Parameter	T <sub>A</sub> = -40°C		T <sub>A</sub> = 0°C		T <sub>A</sub> = +25°C		T <sub>A</sub> = +85°C		Unit	Condition
		Min.	Max.	Min.	Max.	Min.	Max.	Min.	Max.		
I <sub>CC</sub>	Power Supply Current	—	25	—	25	—	25	—	25	mA	—

**NOTE:**

- Parametric values specified at: 3 volt Power Supply Range 10/100ELT22L Series: +3.0V to +3.8V.

**AC ELECTRICAL CHARACTERISTICS<sup>(1)</sup>**

 V<sub>CC</sub> = +3.0V to +3.8V

Symbol	Parameter	T <sub>A</sub> = -40°C		T <sub>A</sub> = 0°C		T <sub>A</sub> = +25°C		T <sub>A</sub> = +85°C		Unit	Condition
		Min.	Max.	Min.	Max.	Min.	Max.	Min.	Max.		
t <sub>PLH</sub> t <sub>PHL</sub>	Propagation Delay to Output D, ENECL/ENTTL	100	600	100	600	100	600	100	600	ps	50Ω to V <sub>CC</sub> - 2.0V
t <sub>r</sub> t <sub>f</sub>	Output Rise/Fall Time 20% to 80%	200	500	200	500	200	500	200	500	ps	50Ω to V <sub>CC</sub> - 2.0V
t <sub>skpp</sub>	Part-to-Part Skew <sup>(2)</sup>	—	500	—	500	—	500	—	500	ps	50Ω to V <sub>CC</sub> - 2.0V
t <sub>skew</sub>	Within-Device Skew <sup>(2,3)</sup>	—	200	—	200	—	200	—	200	ps	50Ω to V <sub>CC</sub> - 2.0V

**NOTES:**

- Parametric values specified at: 3 volt Power Supply Range 10/100ELT22L Series: +3.0V to +3.8V.
- Guaranteed, but not tested.
- Same transition @common V<sub>CC</sub> levels.

**TTL DC ELECTRICAL CHARACTERISTICS<sup>(1)</sup>**

 V<sub>CC</sub> = +3.0V to +3.8V

Symbol	Parameter	T <sub>A</sub> = -40°C		T <sub>A</sub> = 0°C		T <sub>A</sub> = +25°C		T <sub>A</sub> = +85°C		Unit	Condition
		Min.	Max.	Min.	Max.	Min.	Max.	Min.	Max.		
V <sub>IH</sub>	Input HIGH Voltage	2.0	—	2.0	—	2.0	—	2.0	—	V	—
V <sub>IL</sub>	Input LOW Voltage	—	0.8	—	0.8	—	0.8	—	0.8	V	—
I <sub>IH</sub>	Input HIGH Current	—	20 100	—	20 100	—	20 100	—	20 100	μA	V <sub>IN</sub> = 2.7V V <sub>IN</sub> = V <sub>CC</sub>
I <sub>IL</sub>	Input LOW Current	—	-0.2	—	-0.2	—	-0.2	—	-0.2	mA	V <sub>IN</sub> = 0.5V
V <sub>IK</sub>	Input Clamp Voltage	—	-1.2	—	-1.2	—	-1.2	—	-1.2	V	I <sub>IN</sub> = -18mA

**NOTE:**

1. Parametric values specified at: 3 volt Power Supply Range 10/100ELT22L Series: +3.0V to +3.8V.

**PECL DC ELECTRICAL CHARACTERISTICS<sup>(1)</sup>**

 V<sub>CC</sub> = V<sub>CC</sub> (Min.) to V<sub>CC</sub> (Max.)

Symbol	Parameter	T <sub>A</sub> = -40°C			T <sub>A</sub> = 0°C			T <sub>A</sub> = +25°C			T <sub>A</sub> = +85°C			Unit
		Min.	Typ.	Max.	Min.	Typ.	Max.	Min.	Typ.	Max.	Min.	Typ.	Max.	
V <sub>OH</sub>	Output HIGH Voltage <sup>(2)</sup>													mV
	10ELT	2220	—	2410	2280	—	2460	2320	—	2490	2390	—	2580	
	100ELT	2220	—	2420	2275	—	2420	2275	—	2420	2275	—	2420	
V <sub>OL</sub>	Output LOW Voltage <sup>(2)</sup>													mV
	10ELT	1350	—	1650	1350	—	1670	1350	—	1670	1350	—	1705	
	100ELT	1470	—	1750	1490	—	1680	1490	—	1680	1490	—	1680	

**NOTES:**

1. Parametric values specified at: 3 volt Power Supply Range 10/100ELT22L Series: +3.0V to +3.8V.

 2. These values are for V<sub>CC</sub> = 3.3V. Level Specifications will vary 1:1 with V<sub>CC</sub>.

**PRODUCT ORDERING CODE**

Ordering Code	Package Type	Operating Range	V <sub>CC</sub> Range (V)
SY10ELT22LZC	Z8-1	Commercial	+3.0 to +3.8
SY10ELT22LZCTR	Z8-1	Commercial	+3.0 to +3.8
SY100ELT22LZC	Z8-1	Commercial	+3.0 to +3.8
SY100ELT22LZCTR	Z8-1	Commercial	+3.0 to +3.8

Ordering Code	Package Type	Operating Range	V <sub>CC</sub> Range (V)
SY10ELT22LZI	Z8-1	Industrial	+3.0 to +3.8
SY10ELT22LZITR	Z8-1	Industrial	+3.0 to +3.8
SY100ELT22LZI	Z8-1	Industrial	+3.0 to +3.8
SY100ELT22LZITR	Z8-1	Industrial	+3.0 to +3.8

**8 LEAD PLASTIC SOIC (Z8-1)**

FILE/REV #: PD0032A03  
PD/0032/ASCORP  
PAGE 1 OF 1

REV.	REVISION DESCRIPTION	DATE
00	NEW OUTLINE DRAWING.	01/20/94
01	CONVERT TO AUTOCAD. REFERENCE AMKOR DWG. NO. 00019 REVOS. MAKE @ SAME AS JEDEC.	12/14/96
02	ADDED LEAD WIDTH AND PITCH DIMENSIONS. CORRECTED TYPOS.	03/12/97
03	CONVERT DWG TO REL.13 AND ONE PAGE DOCUMENT.	02/20/98

TOP VIEW

END VIEW

BOTTOM VIEW

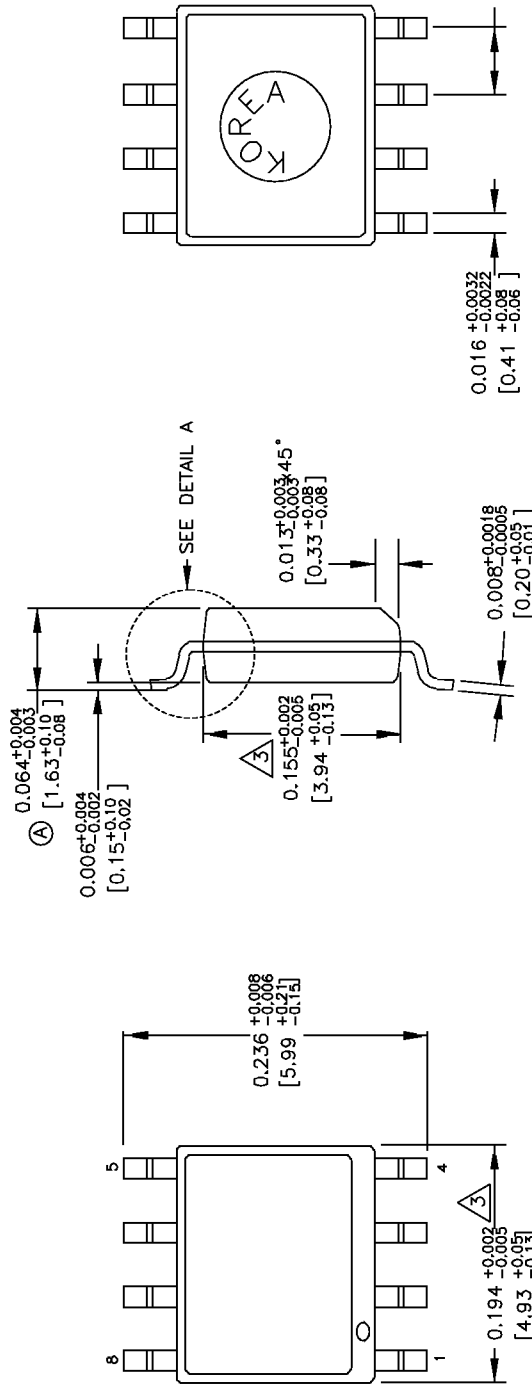

**NOTES:**

1. DIMENSIONS ARE IN INCHES[MM].
2. CONTROLLING DIMENSION: INCHES.
3. DIMENSION DOES NOT INCLUDE MOLD FLASH OR PROTRUSIONS, EITHER OF WHICH SHALL NOT EXCEED 0.006[0.152] PER SIDE.

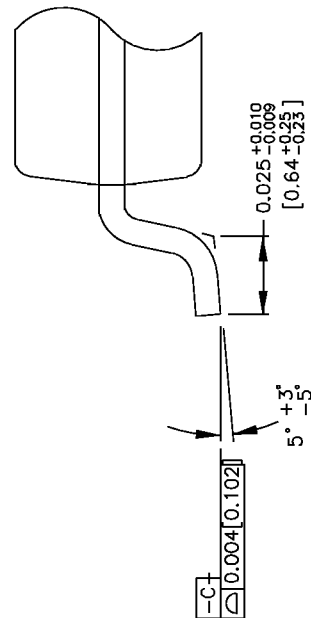

3250 SCOTT BOULEVARD  
SANTA CLARA, CA 95054  
TEL: 408-587-1919  
FAX: 408-587-7878

APPROVALS	DATE	APPROVALS	DATE	SIZE	PACKAGE OUTLINE	SCALE
ORIGINATOR: ERMIN G. URRUTIA	02/23/98	QUALITY: MARSHALL WILDER		A	8 LEAD PLASTIC SOIC (.150" WIDE)	N/A
CHK'D: WON CHANG		DOCUMENT CONTROL: BRIAN SANFILIPPO				
RELEASE DATE:						REVISION 03

THESE SPECIFICATIONS ARE THE PROPERTY OF SYNERGY SEMICONDUCTOR. ARE ISSUED IN STRICT CONFIDENCE AND SHALL BE KEPT UNDER LOCK AND KEY. NO REPRODUCTION FOR THE MANUFACTURE OR SALE OF APPARATUS WITHOUT WRITTEN PERMISSION.