

# Instrument Transformers

## Through-type CT/CC3M

### CC3M rectangular hole through-type current transformers

Primary current: 150 to 6000A

Secondary current: 5A

#### ■ Description

CC3M CTs can be mounted vertically or horizontally by changing the position of the mounting base. Also, the busbar can be mounted directly using a mounting bracket as illustrated, so a busbar mounting angle or holes are not required.

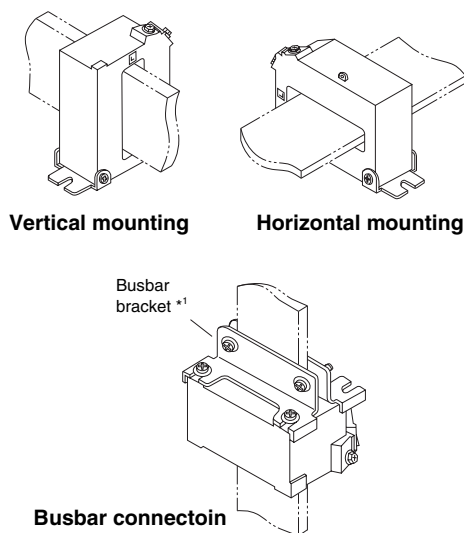

#### ■ Types and ratings

Burden (VA)	Rated primary current (A)	Secondary current (A)	Accuracy class	Thermal limit current	Max. voltage (kV rms.)	Dielectric strength (kV 1 min.)	Mass (kg)	Type		
5	150	5	1.0	40 times rated primary current	1.15kV	4.0kV	2.1	CC3M1-1505		
	200						1.1	CC3M1-2005 CC3M1-3005		
	300						0.6	CC3M1-4005 CC3M1-5005 CC3M1-6005		
	400									
	500 600									
15	150	5 or 1	1.0	40 times rated primary current	1.15kV	4.0kV	2.1	CC3M2-150□		
	200	5 or 1	1.0		1.15kV	4.0kV	1.1	CC3M2-200□ CC3M2-250□ CC3M2-300□		
	250									
	300	5 or 1	1.0		1.15kV	4.0kV	0.6	CC3M2-400□ CC3M2-500□		
	400									
	500									
	600						0.5	CC3M2-600□ CC3M2-750□ CC3M2-800□		
	750									
	800									
	1000	5 or 1	1.0		40 times rated primary current	1.15kV	4.0kV	1.2	CC3M2-10X□ CC3M2-12X□ CC3M2-15X□ CC3M2-20X□	
1200										
1500	5 or 1	1.0	40 times rated primary current	1.15kV	4.0kV	2.3	CC3M3-200□ CC3M3-250□			
2000										
40	200	5 or 1	1.0	40 times rated primary current	1.15kV	4.0kV	1.1	CC3M3-300□ CC3M3-400□ CC3M3-500□		
	250	5 or 1	1.0					1.15kV	4.0kV	1.1
	300									
	400						5 or 1			1.0
	500									
	600	1.3	CC3M3-15X□ CC3M3-20X□							
	750									
	800	0.9	CC3M3-25X5 CC3M3-30X5							
	1000		1.2				CC3M3-40X5			
	1200	1.5					CC3M3-50X5 CC3M3-60X5			
1500	4.8		CC3M3-25X5 CC3M3-30X5							
2000		6.3	CC3M3-40X5							
2500	5		1.0	40 times rated primary current	1.15kV	4.0kV	14	CC3M3-50X5 CC3M3-60X5		
3000										
4000	5	1.0	40 times rated primary current	1.15kV	4.0kV	14	CC3M3-50X5 CC3M3-60X5			
5000*2										
6000*2										

Notes: \*1 Busbar mounting brackets are sold separately. When ordering, specify the CT type number and rated primary current. If the rated primary current is 1000 to 2000A, also specify the number of busbars required.

\*2 Epoxy resin mold is used to isolate rated primary currents of 5000 or 6000A.

- CC3M CTs are mounted vertically at the factory.
- Replace the □ mark by the secondary current code.  
5: 5A 1: 1A

■ Type number nomenclature

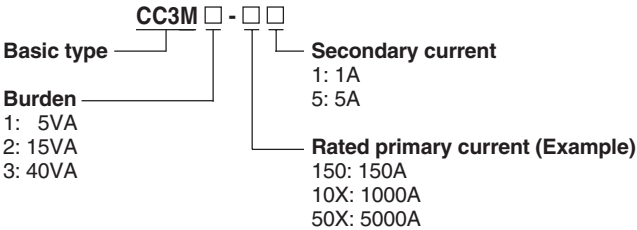

■ Ordering information

- Specify the following:
1. Type number
  2. Busbar mounting bracket if required.  
Primary current

# Instrument Transformers Through-type CT/CC3M

## ■ Dimensions, mm

### ● Vertical mounting

CC3M1: 150 to 300A CC3M2: 200 to 300A  
CC3M3: 300 to 500A

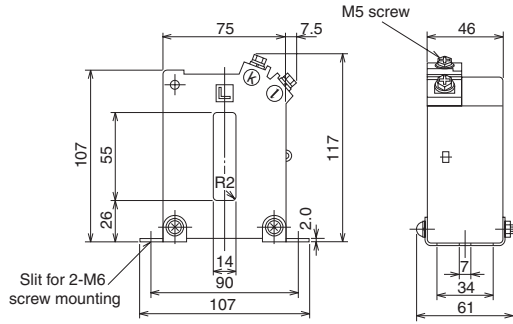

### ● Horizontal mounting

CC3M1: 150 to 300A CC3M2: 200 to 300A  
CC3M3: 300 to 500A

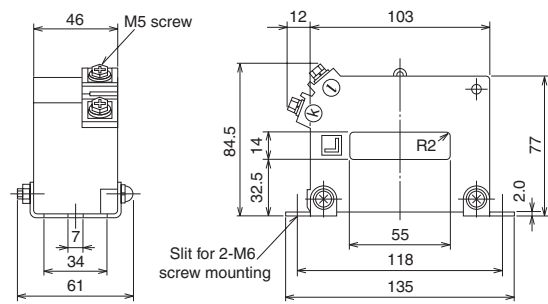

CC3M1: 400 to 600A CC3M2: 400 to 750A

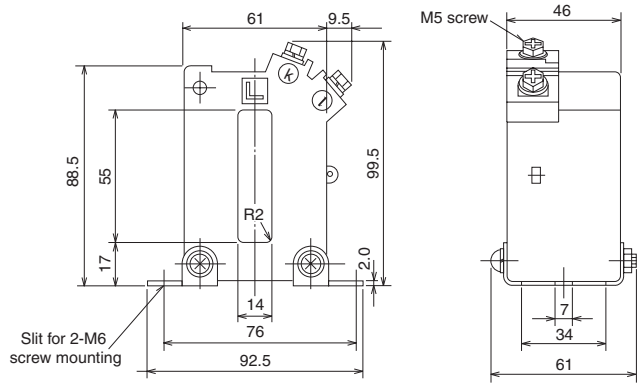

CC3M1: 400 to 600A CC3M2: 400 to 750A

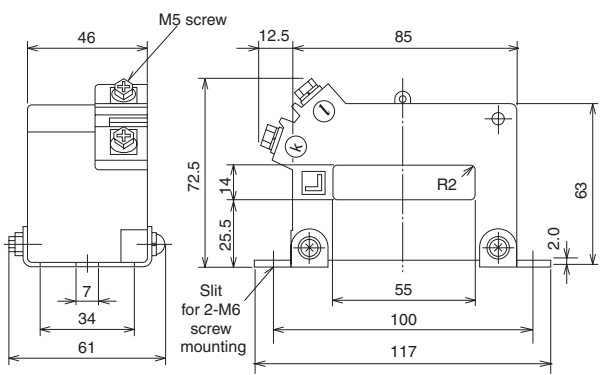

CC3M2: 150A  
CC3M3: 200, 250A

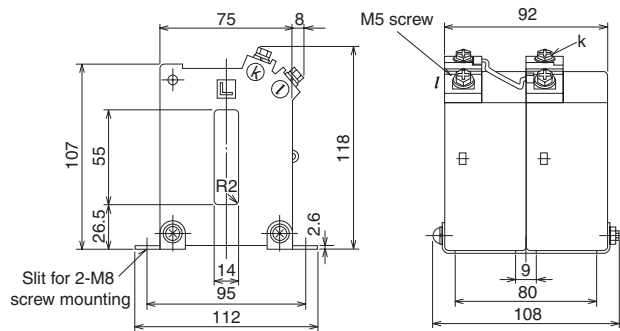

CC3M2: 150A  
CC3M3: 200, 250A

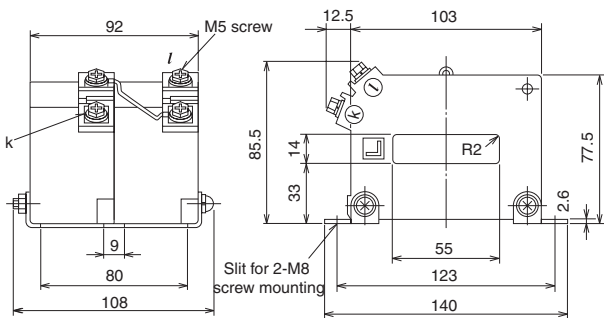

CC3M2: 800A CC3M3: 600 to 800A

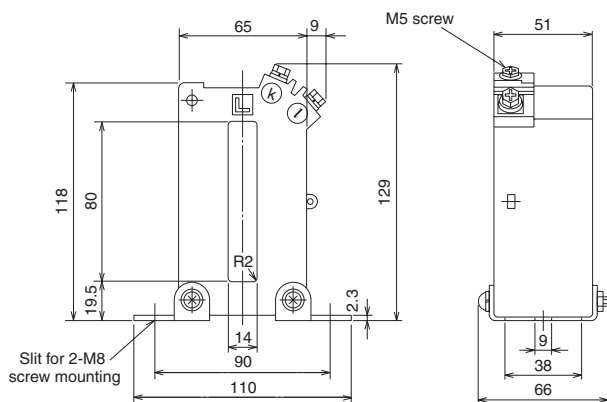

CC3M2: 800A CC3M3: 600 to 800A

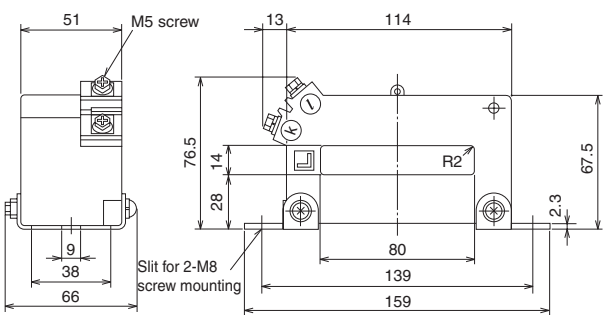

■ Dimensions, mm  
● Vertical mounting

CC3M2, CC3M3: 1000 to 2000A

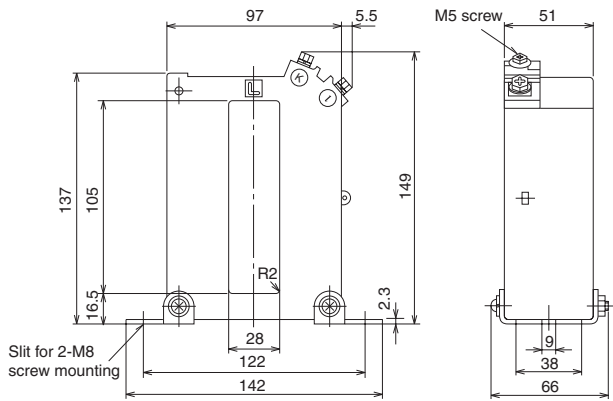

● Horizontal mounting

CC3M2, CC3M3: 1000 to 2000A

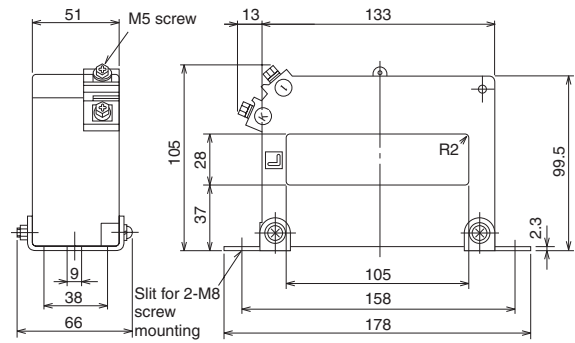

CC3M3: 2500 to 4000A

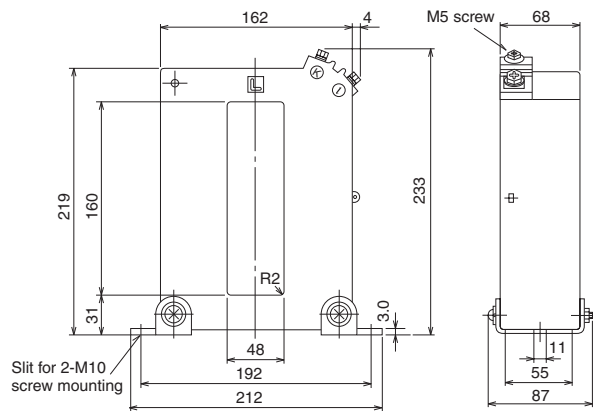

CC3M3: 2500 to 4000A

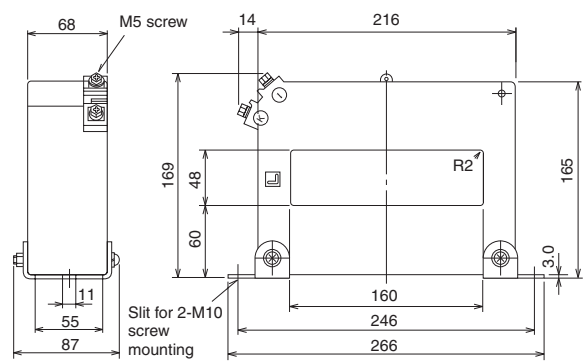

CC3M3: 5000, 6000A

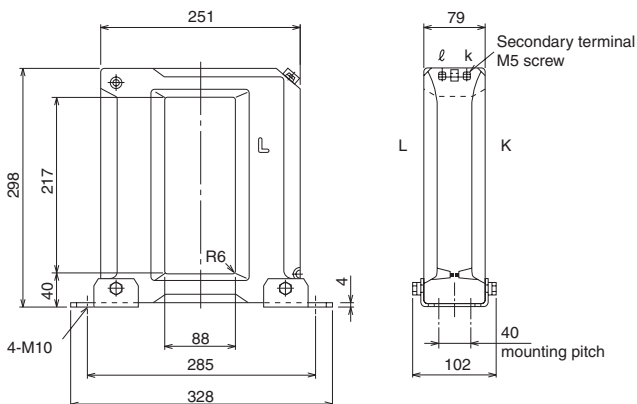

CC3M3: 5000, 6000A

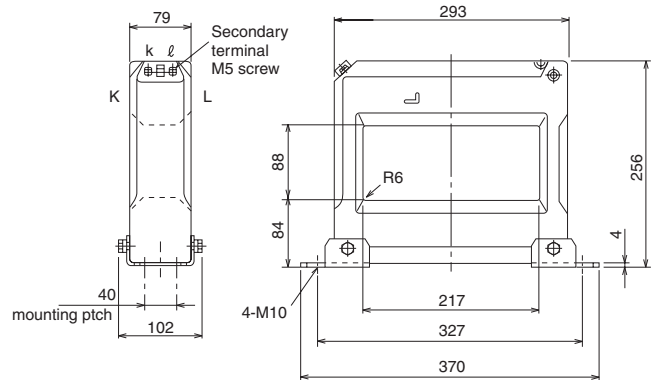

# Instrument Transformers Through-type CT/CC3M

## ■ Dimensions, mm

### Direct busbar mounting

CC3M2 CTs with a rated primary current of 150A or CC3M3 CTs with a rated primary current of 200A, 250A or 4000 to 6000A cannot be mounted directly to a busbar because the CT is too heavy for the cross section of the busbar.

The busbar must be located in the center of the through hole of the CT. Be sure that the busbar does not come into contact with the wall of the through hole.

### ● Single busbar mounting

CC3M1: 150 to 600A CC3M2: 200 to 2000A CC3M3: 300 to 2000A

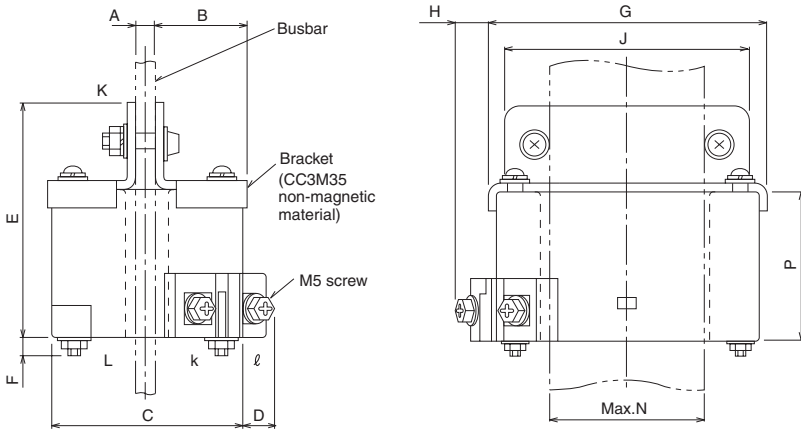

Type	Primary current (A)	Bracket type	A	B	C	D	E	F	G	H	J	N	P
CC3M1	150 to 300	CC3M33	5 to 10	33.5	75	7.5	74	6.5	110	8.5	90	50	46
	400 to 600	CC3M22	5 to 10	26.5	61	9.5	73.5	7	90.5	9.5	81	50	46
CC3M2	200 to 300	CC3M33	5 to 10	33.5	75	7.5	74	6.5	110	8.5	90	50	46
	400 to 750	CC3M22	5 to 10	26.5	61	9.5	73.5	7	90.5	9.5	81	50	46
	800	CC3M34	5 to 10	27.5	65	9	79	6.5	121	9	107	75	51
	1000 to 2000	CC3M35	6 to 12	43.5	97	5.5	80.5	7	139	10	129	100	51
CC3M3	300 to 500	CC3M33	5 to 10	33.5	75	7.5	74	6.5	110	8.5	90	50	46
	600 to 800	CC3M34	5 to 10	27.5	65	9	79	6.5	121	9	107	75	51
	1000 to 2000	CC3M35	6 to 12	43.5	97	5.5	80.5	7	139	10	129	100	51

### ● Two-busbar mounting

CC3M2, CC3M3: 1000 to 3000A

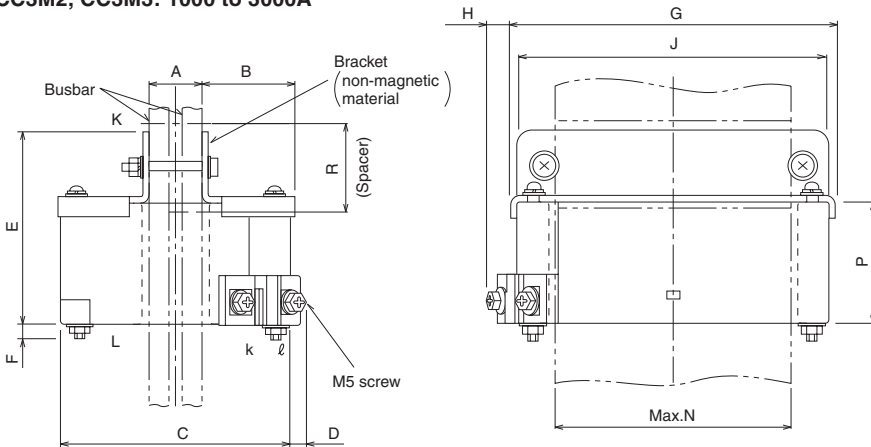

Primary current (A)	Bracket type	A	B	C	D	E	F	G	H	J	N	P	R
1000, 1200, 1500, 2000	CC3M36	15 to 24	39	97	5.5	80.5	7	139	10	129	100	51	Approx. 40
2500, 3000	CC3M37	15 to 45	72	162	4	102	17	223	11	210	150	68	Approx. 60