

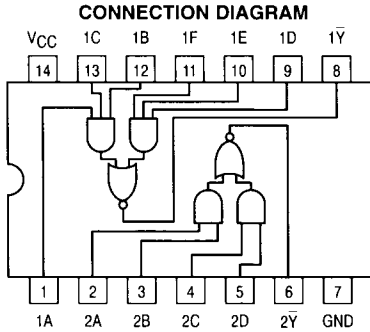

DUAL 2-WIDE 2-INPUT, 2-WIDE 3-INPUT AND-OR-INVERT GATE



MC54/74F51

DUAL 2-WIDE 2-INPUT, 2-WIDE 3-INPUT AND-OR-INVERT GATE
FAST™ SCHOTTKY TTL

FUNCTION TABLE

For 3-Input Gates							For 2-Input Gates				
Inputs			Inputs		Output		Inputs				Output
A	B	C	D	E	F	1Ȳ	A	B	C	D	2Ȳ
H	H	H	X	X	X	L	H	H	X	X	L
X	X	X	H	H	H	L	X	X	H	H	L
All other combinations						H	All other combinations				H

H = HIGH Voltage Level
 L = LOW Voltage Level
 X = Don't Care

LOGIC SYMBOL

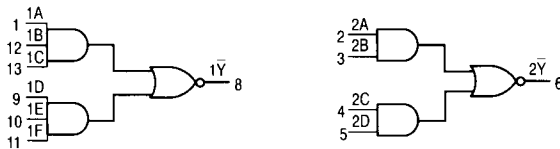

GUARANTEED OPERATING RANGES

Symbol	Parameter		Min	Typ	Max	Unit
V _{CC}	Supply Voltage	54, 74	4.5	5.0	5.5	V
T _A	Operating Ambient Temperature Range	54	-55	25	125	°C
		74	0	25	70	
I _{OH}	Output Current -- High	54, 74			-1.0	mA
I _{OL}	Output Current -- Low	54, 74			20	mA

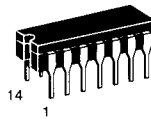

J SUFFIX
 CERAMIC
 CASE 632-08

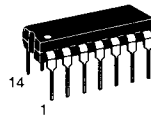

N SUFFIX
 PLASTIC
 CASE 646-06



D SUFFIX
 SOIC
 CASE 751A-02

ORDERING INFORMATION

MC54FXXJ Ceramic
 MC74FXXN Plastic
 MC74FXXD SOIC

4

MC54/74F51

DC CHARACTERISTICS OVER OPERATING TEMPERATURE RANGE (unless otherwise specified)

Symbol	Parameter		Limits			Unit	Test Conditions	
			Min	Typ	Max			
V _{IH}	Input HIGH Voltage		2.0			V	Guaranteed Input HIGH Voltage	
V _{IL}	Input LOW Voltage				0.8	V	Guaranteed Input LOW Voltage	
V _{IK}	Input Clamp Diode Voltage				-1.2	V	V _{CC} = MIN, I _{IN} = -18 mA	
V _{OH}	Output HIGH Voltage	54, 74	2.5			V	I _{OH} = -1.0 mA	V _{CC} = 4.50 V
		74	2.7			V	I _{OH} = -1.0 mA	V _{CC} = 4.75 V
V _{OL}	Output LOW Voltage				0.5	V	I _{OL} = 20 mA	V _{CC} = MIN
I _{IH}	Input HIGH Current				20	μA	V _{CC} = MAX, V _{IN} = 2.7 V	
					0.1	mA	V _{CC} = MAX, V _{IN} = 7.0 V	
I _{IL}	Input LOW Current				-0.6	mA	V _{CC} = MAX, V _{IN} = 0.5 V	
I _{OS}	Output Short Circuit Current (Note 2)		-60		-150	mA	V _{CC} = MAX, V _{OUT} = 0 V	
I _{CC}	Total Supply Current	I _{CCH}	1.8	3.0		mA	V _{IN} = GND	V _{CC} = MAX
		I _{CCL}	5.5	7.5			V _{IN} = 4.5 V	

NOTES:

- For conditions shown as MIN or MAX, use the appropriate value specified under recommended operating conditions for the applicable device type.
- Not more than one output should be shorted at a time, nor for more than 1 second.

AC ELECTRICAL CHARACTERISTICS

Symbol	Parameter	54/74F			54F		74F		Unit
		T _A = +25°C			T _A = -55°C to +125°C		T _A = 0°C to +70°C		
		Min	Typ	Max	Min	Max	Min	Max	
t _{PLH}	Propagation Delay	2.0		5.5	1.5	7.5	1.5	6.5	ns
t _{PHL}	A, B, C, D, E, F, to n \bar{Y}	1.0		4.0	1.0	5.5	1.0	4.5	

4