

SN54H52, SN74H52

Expandable 4-Wide AND-OR Gates

These devices contain expandable 4-wide AND-OR gates. In the J and N packages they perform the Boolean function $Y = AB + CDE + FG + HI + X$ and in the W package $Y = AB + CD + EF + GHI + X$ with $X =$ output of SN54H61/SN74H61. The SN54H52 is characterized for operation over the full military temperature range of -55°C to 125°C while the SN74H52 is characterized for operation from 0°C to 70°C .

Rochester Electronics Manufactured Components

Rochester branded components are manufactured using either die/wafers purchased from the original suppliers or Rochester wafers recreated from the original IP. All recreations are done with the approval of the OCM.

Parts are tested using original factory test programs or Rochester developed test solutions to guarantee product meets or exceeds the OCM data sheet.

Quality Overview

- ISO-9001
- AS9120 certification
- Qualified Manufacturers List (QML) MIL-PRF-38535
 - Class Q Military
 - Class V Space Level
- Qualified Suppliers List of Distributors (QSLD)
 - Rochester is a critical supplier to DLA and meets all industry and DLA standards.

Rochester Electronics, LLC is committed to supplying products that satisfy customer expectations for quality and are equal to those originally supplied by industry manufacturers.

The original manufacturer's datasheet accompanying this document reflects the performance and specifications of the Rochester manufactured version of this device. Rochester Electronics guarantees the performance of its semiconductor products to the original OEM specifications. 'Typical' values are for reference purposes only. Certain minimum or maximum ratings may be based on product characterization, design, simulation, or sample testing.

TYPES SN54H52, SN74H52 EXPANDABLE 4-WIDE AND-OR GATES

REVISED DECEMBER 1983

- Package Options Include Plastic and Ceramic DIPs
- Dependable Texas Instruments Quality and Reliability

description

These devices contain expandable 4-wide AND-OR gates. In the J and N packages they perform the Boolean function $Y = AB + CDE + FG + HI + X$ and in the W package $Y = AB + CD + EF + GHI + X$ with X = output of SN54H61/SN74H61.

The SN54H52 is characterized for operation over the full military temperature range of -55°C to 125°C . The SN74H52 is characterized for operation from 0°C to 70°C .

logic diagrams

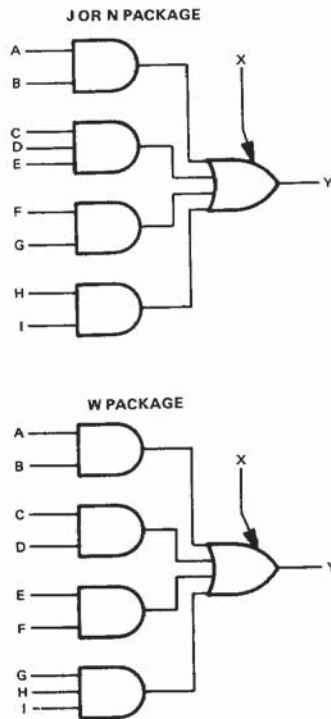

SN54H52 . . . J PACKAGE
SN74H52 . . . J OR N PACKAGE
(TOP VIEW)

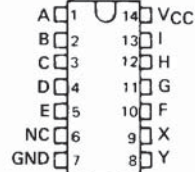

SN54H52 . . . W PACKAGE
(TOP VIEW)

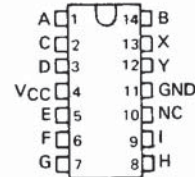

NC - No internal connection

PRODUCTION DATA
This document contains information current as of publication date. Products conform to specifications per the terms of Texas Instruments standard warranty. Production processing does not necessarily include testing of all parameters.

TEXAS INSTRUMENTS
POST OFFICE BOX 225012 • DALLAS, TEXAS 75265

**TYPES SN54H52, SN74H52
EXPANDABLE 4-WIDE AND-OR GATES**

schematic

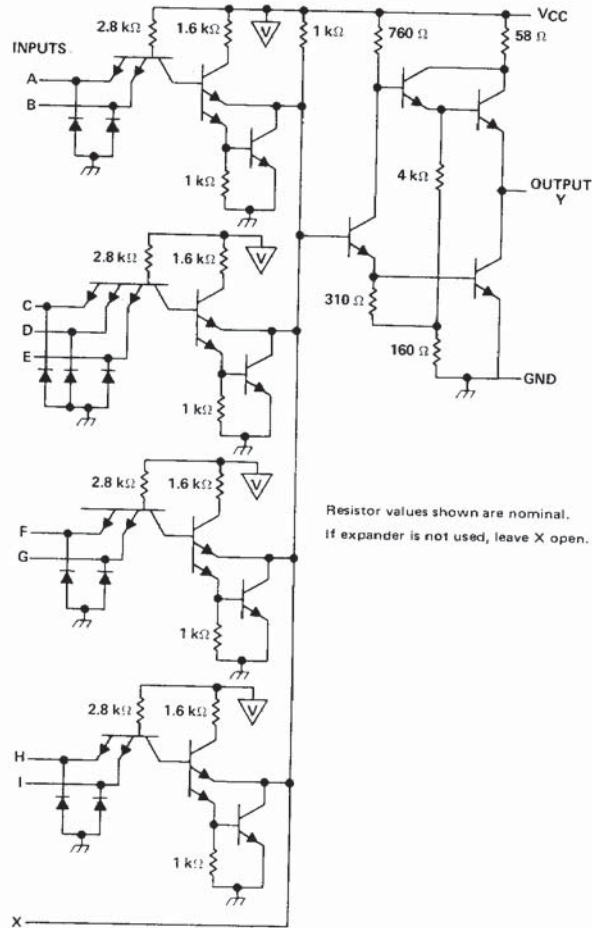

3
TTL DEVICES

absolute maximum ratings over operating free-air temperature range (unless otherwise noted)

Supply voltage, V_{CC} (see Note 1)	7 V
Input voltage	5.5 V
Operating free-air temperature range: SN54H52	-55°C to 125°C
SN74H52	0°C to 70°C
Storage temperature range	-65°C to 150°C

NOTE 1: Voltage values are with respect to network ground terminal.

TYPES SN54H52, SN74H52 EXPANDABLE 4-WIDE AND-OR GATES

recommended operating conditions

	SN54H52			SN74H52			UNIT
	MIN	NOM	MAX	MIN	NOM	MAX	
V _{CC} Supply voltage	4.5	5	5.5	4.75	5	5.25	V
V _{IH} High-level input voltage	2			2			V
V _{IL} Low-level input voltage	0.8			0.8			V
I _{OH} High-level output current	-0.5			-0.5			mA
I _{OL} Low-level output current	20			20			mA
T _A Operating free-air temperature	-55	125		0	70		°C

electrical characteristics over recommended operating free-air temperature range (unless otherwise noted)

PARAMETER	TEST CONDITIONS†	SN54H52		SN74H52		UNIT
		MIN	TYP‡	MIN	TYP‡	
V _{IK}	V _{CC} = MIN, I _I = -8 mA	-1.5		-1.5		V
V _{OH}	V _{CC} = MIN, V _{IH} = 2 V, I _{OH} = -0.5 mA	2.4	3.4	2.4	3.4	V
V _{OL}	V _{CC} = MIN, V _{IL} = 0.8 V, I _{OL} = 20 mA	0.2	0.4	0.2	0.4	V
I _I	V _{CC} = MAX, V _I = 5.5 V	1		1		mA
I _{IH}	V _{CC} = MAX, V _{IH} = 2.4 V	50		50		μA
I _{IL}	V _{CC} = MAX, V _{IL} = 0.4 V	-2		-2		mA
I _{OS} §	V _{CC} = MAX	-40	-100	-40	-100	mA
I _{CCH}	V _{CC} = MAX, See Note 2	20	31	20	31	mA
I _{CCL}	V _{CC} = MAX, V _I = 0 V	15.2	24	15.2	24	mA
I _X ▲	V _X = 1 V, I _{OH} = -0.5 mA	-2.7	-4.5	-2.9	-5.35	mA
V _{OH} ▲	V _X = 1 V, I _{OH} = -0.5 mA	2.4	3.4	2.4	3.4	V
V _{OL} ▲	I _X = -0.3 mA, I _{OL} = 20 mA, T _A = MAX	0.2	0.4	0.2	0.4	V

† For conditions shown as MIN or MAX, use the appropriate value specified under recommended operating conditions.

‡ All typical values are at V_{CC} = 5 V, T_A = 25°C.

§ Not more than one output should be shorted at a time, and the duration of the short circuit should not exceed one second.

NOTE 2: All inputs of one AND gate at 4.5 V, all others at GND.

▲ Using expander inputs, V_{CC} = MIN, T_A = MIN (unless otherwise noted).

switching characteristics, V_{CC} = 5 V, T_A = 25°C (see note 3)

PARAMETER	FROM (INPUT)	TO (OUTPUT)	TEST CONDITIONS	MIN	TYP	MAX	UNIT
t _{PLH}	Any	Y	R _L = 280 Ω, C _L = 25 pF	10.6	15		ns
t _{PHL}			Expander pins open	9.2	15		ns
t _{PLH}			R _L = 280 Ω, C _L = 25 pF, C = 15 pF	14.8			ns
t _{PHL}			Ground to X	9.8			ns

NOTE 3: See General Information Section for load circuits and voltage waveforms.

3

TTL DEVICES