

SN54HC7032, SN74HC7032 QUADRUPLE POSITIVE-OR GATES WITH SCHMITT-TRIGGER INPUTS

SCLS036B – MARCH 1984 – REVISED MAY 1997

- This is text in a key features bullet. This is text in a key features bullet.
- Operation From Very Slow Input Transitions
- Temperature-Compensated Threshold Levels
- High Noise Immunity
- Same Pinouts as 'HC32
- Package Options Include Plastic Small-Outline (D) and Ceramic Flat (W) Packages, Ceramic Chip Carriers (FK), and Standard Plastic (N) and Ceramic (J) 300-mil DIPs

description

In these devices, each circuit functions as a quadruple OR gate. They perform the Boolean function $Y = \overline{A} \cdot \overline{B}$ or $Y = A + B$ in positive logic. However, because of the Schmitt action, the inputs have different input threshold levels for positive- and negative-going signals.

These circuits are temperature compensated and can be triggered from the slowest of input ramps and still give clean jitter-free output signals.

The SN54HC7032 is characterized for operation over the full military temperature range of -55°C to 125°C . The SN74HC7032 is characterized for operation from -40°C to 85°C .

SN54HC7032 . . . J OR W PACKAGE
SN74HC7032 . . . D OR N PACKAGE
(TOP VIEW)

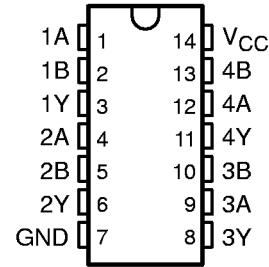

SN54HC7032 . . . FK PACKAGE
(TOP VIEW)

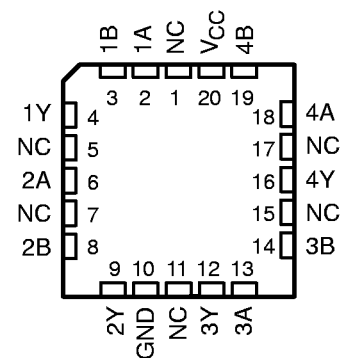

NC – No internal connection

FUNCTION TABLE
(each gate)

INPUTS		OUTPUT
A	B	Y
H	X	H
X	H	H
L	L	L



Please be aware that an important notice concerning availability, standard warranty, and use in critical applications of Texas Instruments semiconductor products and disclaimers thereto appears at the end of this data sheet.

UNLESS OTHERWISE NOTED this document contains PRODUCTION DATA information current as of publication date. Products conform to specifications per the terms of Texas Instruments standard warranty. Production processing does not necessarily include testing of all parameters.

 **TEXAS
INSTRUMENTS**

POST OFFICE BOX 655303 • DALLAS, TEXAS 75265

Copyright © 1997, Texas Instruments Incorporated

SN54HC7032, SN74HC7032 QUADRUPLE POSITIVE-OR GATES WITH SCHMITT-TRIGGER INPUTS

SCLS036B – MARCH 1984 – REVISED MAY 1997

recommended operating conditions

		SN54HC7032			SN74HC7032			UNIT
		MIN	NOM	MAX	MIN	NOM	MAX	
V_{CC}	Supply voltage	2	5	6	2	5	6	V
V_{IH}	High-level input voltage	$V_{CC} = 2\text{ V}$	1.5		1.5			V
		$V_{CC} = 4.5\text{ V}$	3.15		3.15			
		$V_{CC} = 6\text{ V}$	4.2		4.2			
V_{IL}	Low-level input voltage	$V_{CC} = 2\text{ V}$	0	0.5	0	0.5		V
		$V_{CC} = 4.5\text{ V}$	0	1.35	0	1.35		
		$V_{CC} = 6\text{ V}$	0	1.8	0	1.8		
V_I	Input voltage	V_{CC}			0	V_{CC}		V
V_O	Output voltage	0	V_{CC}		0	V_{CC}		V
T_A	Operating free-air temperature	-55		125	-40		85	°C

electrical characteristics over recommended operating free-air temperature range (unless otherwise noted)

PARAMETER	TEST CONDITIONS		V_{CC}	$T_A = 25^\circ\text{C}$			SN54HC7032		SN74HC7032		UNIT
				MIN	TYP	MAX	MIN	MAX	MIN	MAX	
V_{OH}	$V_I = V_{IH}$ or V_{IL}	$I_{OH} = -20\ \mu\text{A}$	2 V	1.9	1.998		1.9		1.9	V	
			4.5 V	4.4	4.499		4.4		4.4		
			6 V	5.9	5.999		5.9		5.9		
		$I_{OH} = -4\ \text{mA}$	4.5 V	3.98	4.3		3.7		3.84		
		$I_{OH} = -5.2\ \text{mA}$	6 V	5.48	5.8		5.2		5.34		
V_{OL}	$V_I = V_{IH}$ or V_{IL}	$I_{OL} = 20\ \mu\text{A}$	2 V		0.002	0.1		0.1		0.1	V
			4.5 V		0.001	0.1		0.1		0.1	
			6 V		0.001	0.1		0.1		0.1	
		$I_{OL} = 4\ \text{mA}$	4.5 V		0.17	0.26		0.4		0.33	
		$I_{OL} = 5.2\ \text{mA}$	6 V		0.15	0.26		0.4		0.33	
V_{T+}			2 V	0.7	1.2	1.5	0.7	1.5	0.7	1.5	V
			4.5 V	1.55	2.5	3.15	1.55	3.15	1.55	3.15	
			6 V	2.1	3.3	4.2	2.1	4.2	2.1	4.2	
V_{T-}			2 V	0.3	0.6	1	0.3	1	0.3	1	V
			4.5 V	0.9	1.6	2.45	0.9	2.45	0.9	2.45	
			6 V	1.2	2	3.2	1.2	3.2	1.2	3.2	
$V_{T+} - V_{T-}$			2 V	0.2	0.6	1.2	0.2	1.2	0.2	1.2	V
			4.5 V	0.4	0.9	2.1	0.4	2.1	0.4	2.1	
			6 V	0.5	1.3	2.5	0.5	2.5	0.5	2.5	
I_I	$V_I = V_{CC}$ or 0		6 V		± 0.1	± 100		± 1000		± 1000	nA
I_{CC}	$V_I = V_{CC}$ or 0, $I_O = 0$		6 V			2		40		20	μA
C_i			2 V to 6 V		3	10		10		10	pF

PRODUCT PREVIEW information concerns products in the formative or design phase of development. Characteristic data and other specifications are design goals. Texas Instruments reserves the right to change or discontinue these products without notice.



SN54HC7032, SN74HC7032 QUADRUPLE POSITIVE-OR GATES WITH SCHMITT-TRIGGER INPUTS

SCLS036B – MARCH 1984 – REVISED MAY 1997

switching characteristics over recommended operating free-air temperature range, $C_L = 50$ pF (unless otherwise noted) (see Figure 1)

PARAMETER	FROM (INPUT)	TO (OUTPUT)	V_{CC}	$T_A = 25^\circ\text{C}$			SN54HC7032		SN74HC7032		UNIT
				MIN	TYP	MAX	MIN	MAX	MIN	MAX	
t_{pd}	A or B	Y	2 V	60	130	195	163	ns			
			4.5 V	18	26	39	33				
			6 V	14	22	33	28				
t_t	Any	Any	2 V	28	75	110	95	ns			
			4.5 V	8	15	22	19				
			6 V	6	13	19	16				

operating characteristics, $T_A = 25^\circ\text{C}$

PARAMETER	TEST CONDITIONS	TYP	UNIT
C_{pd} Power dissipation capacitance per gate	No load	20	pF

PARAMETER MEASUREMENT INFORMATION

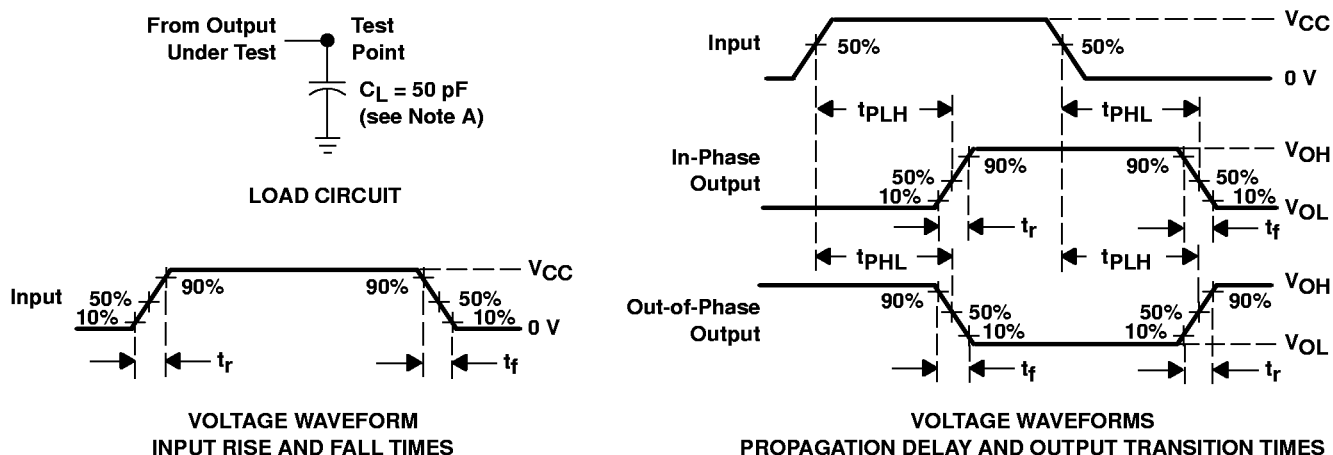

- NOTES: A. C_L includes probe and test-fixture capacitance.
 B. Phase relationships between waveforms were chosen arbitrarily. All input pulses are supplied by generators having the following characteristics: $PRR \leq 1$ MHz, $Z_O = 50 \Omega$, $t_r = 6$ ns, $t_f = 6$ ns.
 C. The outputs are measured one at a time with one input transition per measurement.
 D. t_{PLH} and t_{PHL} are the same as t_{pd} .

Figure 1. Load Circuit and Voltage Waveforms