

Model 150T

Model 151T

Model 152T

**SmartStep® Relay Switched Programmable Attenuators,
with built-in Microprocessor-Based Driver**

dc to 18.0 GHz

dc to 4.0 GHz

dc to 26.5 GHz

For Use with Weinschel 8210A Controller

 **RoHS**



Description

Aeroflex / Weinschel's line of intelligent programmable step attenuators with a built-in TTL interface (Figure 1). These models are designed to simplify the control and integration of these devices into subsystem and bench applications. These intelligent attenuators offer the same long reliable operation with exceptional accuracy and repeatability as with our other 150 Series Programmable Attenuators. They provide programmable adjustments of RF signal levels in precise steps of 1 dB, 5 dB, 10 dB, or with custom steps available. Each attenuator consists of a cascaded assembly of switched attenuator cells and a internal TTL interface.

The attenuator elements located in the attenuator cell are created by a thin-film process which provides exceptional long-term stability, low power and temperature coefficients. This series of step attenuators uses a reed switching structure that provides rapid switching together with low insertion loss.

BUILT-IN DRIVER CIRCUITRY: These programmable attenuators feature an internal microcontroller-based driver that provides a TTL-level digital interface for control of the attenuator relays. This card simplifies operation and interfacing requirements, while at the same time providing for greatly enhanced flexibility over past designs. User-selectable modes of operation include both parallel and serial bus. The parallel mode provides a simple, one-bit per relay on/off control with internal pullups for use primarily in single attenuator applications. This mode allows the attenuator to be controlled via a variety of methods, such as a TTL-level digital output port, or mechanical toggle switches. The device bus provides a two-wire serial bus structure and protocol for connecting a number of devices to a single host control interface, suitable for use in larger system and subsystem applications. The driver interface contains non-volatile configuration memory that is used to hold a wide variety of attenuator and driver-dependent parameters, including serial number, attenuator cell dB values, relay configurations, and switching requirements, which are all accessible via the digital interface. This frees the system designer from such low-level details, allowing faster integration. In either operational mode, the microcontroller enters an idle condition during periods of inactivity, turning off all on-board clocks, reducing EMI concerns, and lowering power consumption. On-board regulation for the digital circuitry allows the programmable attenuator to operate from a single input supply voltage.

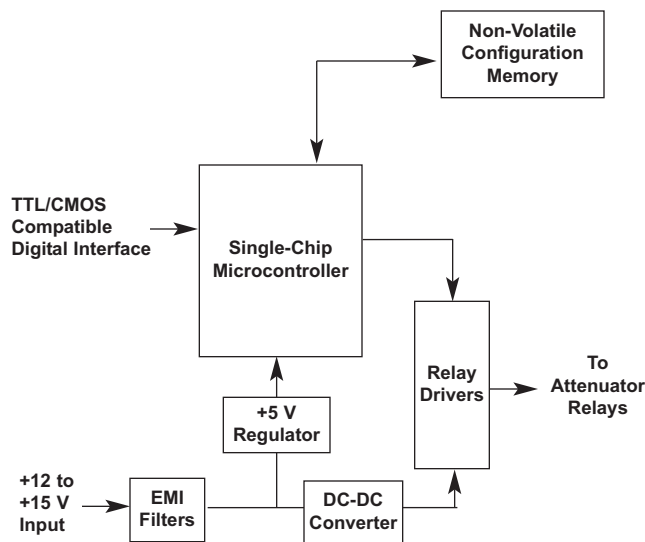

Figure 1. Built-In Driver Circuitry

Other features include:

- /// Wide Variety of Frequency & Attenuation Ranges
- /// Broadband Frequency Coverage
- /// High Accuracy and Repeatability
- /// Long Life, 5 Million Cycles Per Cell
- /// Common 14 pin Interface Connector
- /// Custom Attenuation Ranges

For additional information on the 150 Series, visit our website @ www.aeroflex.com/AW/programmables.htm

Programmable Attenuators



Specifications

NOMINAL IMPEDANCE: 50 Ω

FREQUENCY RANGE: Model 151T: dc to 4 GHz
 Model 150T: dc to 18 GHz
 Model 152T: dc to 26.5 GHz

CELL CONFIGURATIONS:										
Cell	11	15	31	55	62	70	70	75	90	110
1	1	1	1	5	2	10	10	5	10	10
2	4	8	16	10	32	20	40	40	30	40
3	2	2	2	20	16	20	20	20	20	20
4	4	4	8	20	4	20	--	10	30	40
5	--	--	4	--	8	--	--	--	--	--

DRIVER INTERFACE:

- Input Supply Voltage:** +12.0 to +15.0V
- Control Signals:** TTL/CMOS compatible
- Interface Modes:** parallel / serial
- DC Characteristics (at 25 °C):**
- Digital Interface:**

Parameter	Specification
V _{IL} Low Level input:	-0.5 min, 0.8V max
V _{IH} High Level input:	2.0 min, 5.25V max
I _{PU} Pullup Current	50 μA min, 400 μA max

- Power Supply:**

V _{IN} Supply Voltage:	+12.0 to +15.0V
I _{IN} Supply current:	25 mA
I _{CELL} Supply Current:	150 mA (per cell, switching)

POWER RATING: 1 watt average, 100 watts peak
 (5 μsec pulse width; 0.5% duty cycle)

TEMPERATURE: -20° to +70°C operating
 -55° to +85°C nonoperating

TEMPERATURE COEFFICIENT: <0.0001 dB/dB/C

POWER SENSITIVITY: <0.001 dB/dB/ Watt

RATED SWITCH LIFE: 5 million cycles per cell

RF INPUT CONNECTORS: Rugged female 3.5 mm which mate nondestructively with SMA male connectors per MIL-STD-39012.

INTERFACE CONNECTOR: 14 pin .025 square post header on .1 center. Mates with Amp connector 746285-2 or equivalent (one mating connector included with each unit).

SWITCHING TIME: 20 msec (includes settling time)

CYCLING RATE: 4 Hz max per relay

CONTROL PULSE WIDTH: 20 msec (minimum)

REPEATABILITY: ±0.1 dB typical per cell

VIBRATION*: MIL-STD-202F, Method 204D Cond B

ALTITUDE*: MIL-STD-202F, Method 105C Cond B, 50,000 Ft.

SHOCK*: MIL-STD -202F, Method 213B Cond B, except 10G, 6 msec

HUMIDITY*: MIL-STD-202F, Method 103B, Cond. B (96 Hrs. @ 95%, RH).

MAXIMUM SWR (50 Ω Characteristic Impedance):

APPLICABLE MODELS	Frequency (GHz)		
	dc-4	4-18	18-26.5
151T-11, 151T-15, 151T-31, 151-62T, 151T-75, 151T-110	1.50	---	---
150T-11, 150T-15, 150T-31 150T-62, 150T-75, 150T-110	1.50	1.90	---
151T-70 (3 cell)	1.40	---	---
150T-70 (3 cell)	1.40	1.60	---
152AT-70 (3 cell)	1.40	1.60	1.90
152T-55, 152T-70, 152-75, 152T-90	1.40	1.60	1.90

MAXIMUM INSERTION LOSS (dB):

APPLICABLE MODELS	Frequency (GHz)		
	dc-4	4-18	18-26.5
151T-11, 151T-15, 151T-75, 151T-110	0.90	---	---
150T-11, 150T-15, 150T-75, 150T-110	0.90	2.20	---
151T-31, 151T-62 (5 cell)	1.10	----	----
150T-31, 150T-62 (5 cell)	1.10	2.60*	----
151T-70 (3 cell)	0.70	---	---
150T-70 (3 cell)	0.70	1.60	---
152AT-70 (3 cell)	0.90	2.00	2.98
152T-55, 152T-70, 152T-75, 152T-90	0.90	2.00	2.98

*4-12.4 is 1.80, 12.4-18 is 2.60

WEIGHT: 5 Cell 350 g (12 oz)
 4 Cell 290 g (9.0 oz)
 3 Cell 230 g (8.0 oz)

ACCESSORIES

Programmable Attenuator/Switch Controller: The Model 8210A Programmable Attenuator/Switch Controller provides a flexible, low cost solution for the operation of programmable step attenuators and other electromechanical devices under computer control. Designed to interface to Aeroflex / Weinschel's intelligent programmable attenuators, the 8210A represents a new concept in device control applications for bench test and subsystem designs. The 8210A provides a high-level interface from various industry standard communications interfaces, including IEEE-488 and RS232/RS422/RS485, to the programmable attenuator's serial Driver Interface Bus.

OPTIONAL TEST Data: Test Data is available at an additional cost for all programmable step attenuator models. Standard test Data can be provided in 250 MHz steps for all dc-4 GHz models and in 500 MHz steps for dc-18 and dc-26.5 GHz models.

ATTENUATION ACCURACY (\pm dB with respect to 0 dB reference):

Model 150T/151T/152T-11 & 150T/151T/152T-15:

Frequency	Attenuation Setting (dB)														
Range (GHz)	1	2	3	4	5	6	7	8	9	10	11	12	13	14	15
dc-4	0.2	0.2	0.3	0.3	0.3	0.3	0.4	0.4	0.4	0.4	0.5	0.5	0.5	0.5	0.5
4-12.4	0.3	0.3	0.4	0.4	0.5	0.5	0.6	0.6	0.6	0.6	0.7	0.7	0.7	0.7	0.7
12.4-18	0.5	0.6	0.6	0.6	0.6	0.7	0.7	0.7	0.7	0.8	0.8	0.8	0.8	0.8	0.8
18-26.5	0.5	0.6	0.7	0.8	0.9	0.9	0.9	1.0	1.1	1.1	1.1	1.1	1.1	1.1	1.1

Model 150T/151T-75:

Frequency	Attenuation Setting (dB)														
Range (GHz)	5	10	15	20	25	30	35	40	45	50	55	60	65	70	75
dc-4	0.2	0.2	0.4	0.4	0.5	0.5	0.7	0.7	0.9	0.9	1.1	1.1	1.2	1.2	1.4
4-12.4	0.3	0.3	0.6	0.6	0.9	0.9	1.2	1.2	1.5	1.5	1.8	1.8	2.1	2.1	2.1
12.4-18	0.4	0.4	0.8	0.8	1.2	1.2	1.6	1.6	2.0	2.0	2.4	2.4	2.8	2.8	2.8

Model 150T/151T-31:

Frequency	Attenuation Setting (dB)															
Range (GHz)	1	2	3	4	5	6	7	8	9	10	11	12	13	14	15	16
dc-4	0.2	0.2	0.3	0.3	0.3	0.3	0.4	0.4	0.5	0.4	0.5	0.5	0.5	0.5	0.5	0.5
4-12.4	0.4	0.4	0.5	0.5	0.6	0.6	0.7	0.6	0.7	0.6	0.7	0.7	0.7	0.7	0.7	0.7
12.4-18	0.5	0.5	0.6	0.6	0.6	0.6	0.7	0.7	0.8	0.8	0.8	0.8	0.8	0.8	0.8	0.8

Frequency	Attenuation Setting (dB)														
Range (GHz)	17	18	19	20	21	22	23	24	25	26	27	28	29	30	31
dc-4	0.5	0.6	0.6	0.6	0.6	0.6	0.6	0.6	0.7	0.7	0.7	0.7	0.7	0.8	0.8
4-12.4	0.8	0.8	0.9	0.9	0.9	0.9	0.9	0.9	1.1	1.0	1.0	1.0	1.0	1.1	1.1
12.4-18	0.9	0.9	1.0	1.0	1.0	1.0	1.1	1.1	1.2	1.2	1.2	1.2	1.2	1.3	1.3

Model 150T/151T-62:

Frequency	Attenuation Setting (dB)															
Range (GHz)	2	4	6	8	10	12	14	16	18	20	22	24	26	28	30	32
dc-4	0.3	0.3	0.3	0.4	0.4	0.5	0.5	0.5	0.5	0.5	0.5	0.5	0.5	0.5	0.6	0.6
4-12.4	0.4	0.4	0.4	0.5	0.5	0.6	0.6	0.6	0.7	0.7	0.7	0.8	0.8	0.8	0.8	0.8
12.4-18	0.5	0.5	0.5	0.6	0.6	0.6	0.8	0.8	0.8	0.8	0.8	1.0	1.0	1.0	1.2	1.2

Frequency	Attenuation Setting (dB)															
Range (GHz)	34	36	38	40	42	44	46	48	50	52	54	56	58	60	62	
dc-4	0.6	0.6	0.7	0.7	0.7	0.8	0.8	0.8	0.9	0.9	0.9	1.0	1.0	1.0	1.2	
4-12.4	1.0	1.0	1.1	1.1	1.3	1.4	1.4	1.4	1.5	1.6	1.6	1.6	1.8	1.8	1.8	
12.4-18	1.4	1.4	1.6	1.6	1.8	1.8	2.0	2.0	2.0	2.2	2.2	2.2	2.4	2.4	2.4	

Model 150T/151T/152T-75:

Frequency	Attenuation Setting (dB)														
Range (GHz)	5	10	15	20	25	30	35	40	45	50	55	60	65	70	75
dc-4	0.2	0.2	0.4	0.4	0.5	0.5	0.7	0.7	0.9	0.9	1.1	1.1	1.2	1.2	1.4
4-12.4	0.3	0.3	0.6	0.6	0.9	0.9	1.2	1.2	1.5	1.5	1.8	1.8	2.1	2.1	2.1
12.4-18	0.4	0.4	0.8	0.8	1.2	1.2	1.6	1.6	2.0	2.0	2.4	2.4	2.8	2.8	2.8
18-26.5	0.5	0.5	0.9	0.9	1.2	1.2	1.6	1.6	2.0	2.0	2.4	2.4	2.8	2.8	2.8

Model 150T/151T-70, 150T/151T-110, 152AT-70:

Frequency	Attenuation Setting (dB)										
Range (GHz)	10	20	30	40	50	60	70	80	90	100	110
dc-4	0.2	0.3	0.5	0.7	0.9	1.0	1.2	1.4	1.6	1.7	1.9
4-12.4	0.4	0.7	0.9	1.2	1.5	1.8	2.1	2.4	2.7	3.0	3.0
12.4-18	0.4	0.8	1.2	1.6	2.0	2.4	2.8	3.2	3.6	4.0	4.0
18-26.5	0.6	0.7	0.9	1.5	1.6	2.2	2.9	---	---	---	---

Model 152T-55:

Frequency	Attenuation Setting (dB)										
Range (GHz)	5	10	15	20	25	30	35	40	45	50	55
dc-4	0.2	0.3	0.4	0.4	0.4	0.6	0.6	0.7	0.7	0.8	1.0
4-12.4	0.3	0.4	0.5	0.5	0.5	0.7	0.8	0.9	0.9	1.0	1.3
12.4-18	0.4	0.4	0.5	0.5	0.5	0.8	1.0	1.1	1.1	1.2	1.6
18-26.5	0.5	0.5	0.6	0.6	0.6	0.9	1.2	1.4	1.4	1.5	2.0

Model 152T-70, 152T-90:

Frequency	Attenuation Setting (dB)								
Range (GHz)	10	20	30	40	50	60	70	80	90
dc-4	0.3	0.5	0.6	0.7	0.8	1.0	1.1	1.1	1.2
4-12.4	0.4	0.5	0.7	0.9	1.0	1.3	1.5	1.6	1.7
12.4-18	0.5	0.6	0.8	1.1	1.2	1.4	1.7	1.8	2.1
18-26.5	0.5	0.6	0.9	1.4	1.5	1.8	2.3	2.4	2.8

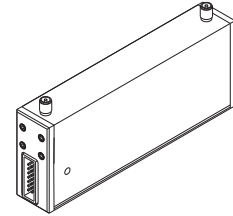

PHYSICAL DIMENSIONS:

Models 150T, 151T, & 152T:

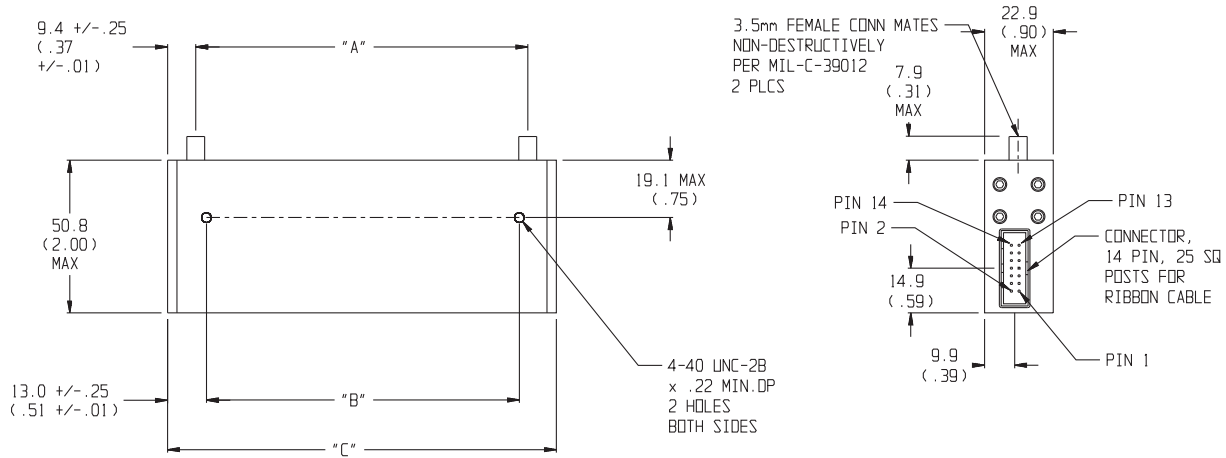

DIM	A	B	C
3 cell	83.3 (3.28)	76.2 (3.0)	101.6 (4.00)
4 cell	110.7 (4.36)	103.6 (4.08)	129.2 (5.09)
5 cell	136.1 (5.36)	129.1 (5.08)	154.4 (6.08)

NOTE:

1. All dimensions are given in mm (inches) and are maximum, unless otherwise specified.
2. Unit available with RoHS compliant materials, specify when ordering.

150T Series Ordering Guide...

Frequency Range	NO. Cells	Attenuator Range/Step Size								
		11/1 dB	15/1 dB	31/1 dB	55/5 dB	62/2 dB	70/10 dB	75/5 dB	90/10 dB	110/10 dB
dc-4 GHz	4	151T-11	151T-15		N/A		151T-70	151T-75	N/A	151T-110
	3									
	5			151T-31		151T-62				
dc-18 GHz	4	150T-11	150T-15		N/A		150T-70	150T-75	N/A	150T-110
	3									
	5			150T-31		150T-62				
dc-26.5 GHz	4	N/A	NA	N/A	152T-55	NA	152T-70	152T-75	152T-90	N/A
	3						152AT-70			