

($\phi 15.5 \pm 0.05$)
5/8" - 24UNEF

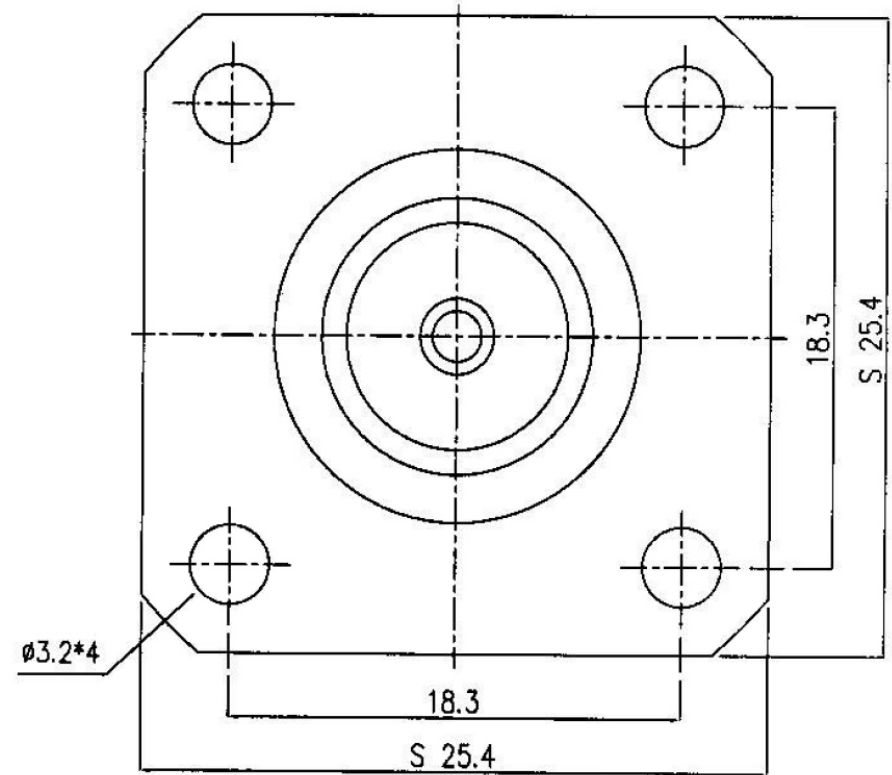
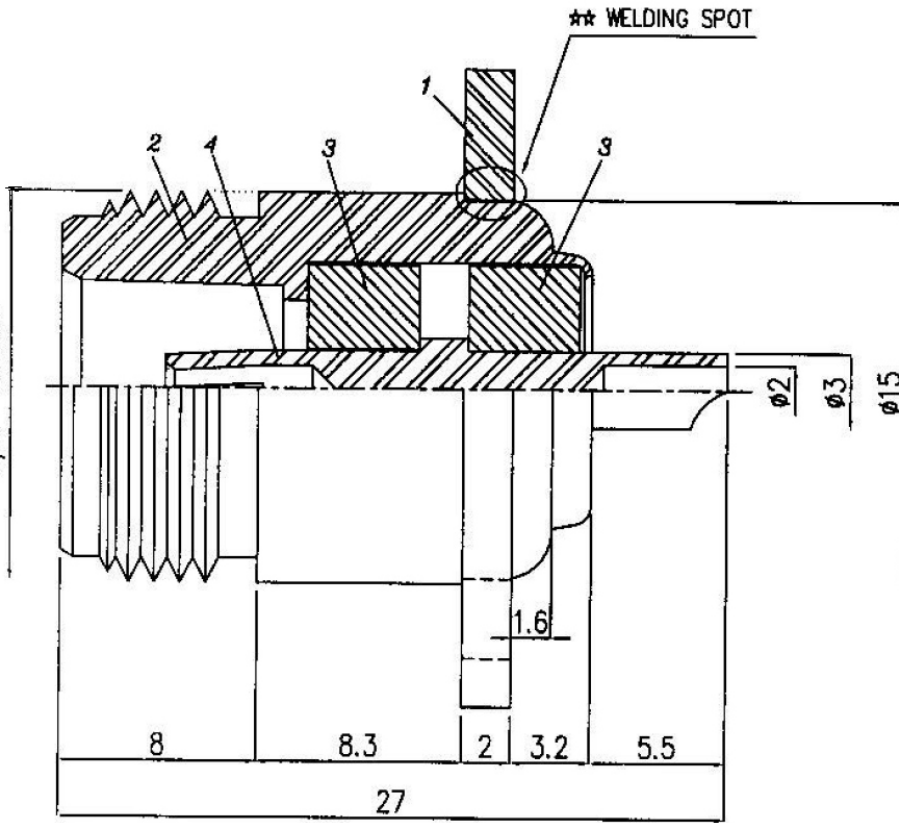

NO	DESCRIPTION	Q'TY	ITEM NO.	MATERIAL	PLATING
1	BODY 1	1	N-245	BRASS	NICKEL 100 μ " MIN.
2	BODY 2	1	N-245-2S	BRASS	NICKEL 100 μ " MIN.
3	DIELECTRIC	2	T-090001	TEFLON	-
4	CENTER PIN	1	N-245	BRASS	GOLD 3-5 μ " MIN.

MORETHANALL
CONNECTORS
ASSEMBLIES

PART NO. **N-JSPQT-50**

DWG NO. **N-JSPQT-50**

FILE NO.

UNIT / mm

SCALE 1:1

CHECKED BY CY

DRAWING BY

PROJECTION

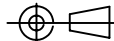

TOLERANCES ARE

.X \pm 0.2
.XX \pm
.XXX \pm
AWG

DESCRIPTION:

AREA

REVISIONS

HK

DATE

煜倫股份有限公司