

Customer Information Sheet

DRAWING No.: S409-XX / S410-XX SHEET 3 OF 4 IF IN DOUBT - ASK © NOT TO SCALE THIRD ANGLE PROJECTION ALL DIMENSIONS IN mm

SEE NOTE 1

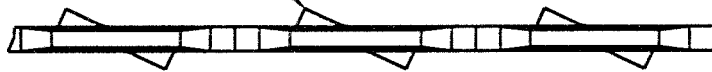

COMPONENTS SHOWN REELED
READY FOR INSERTION

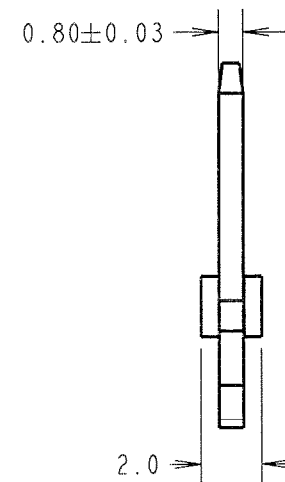
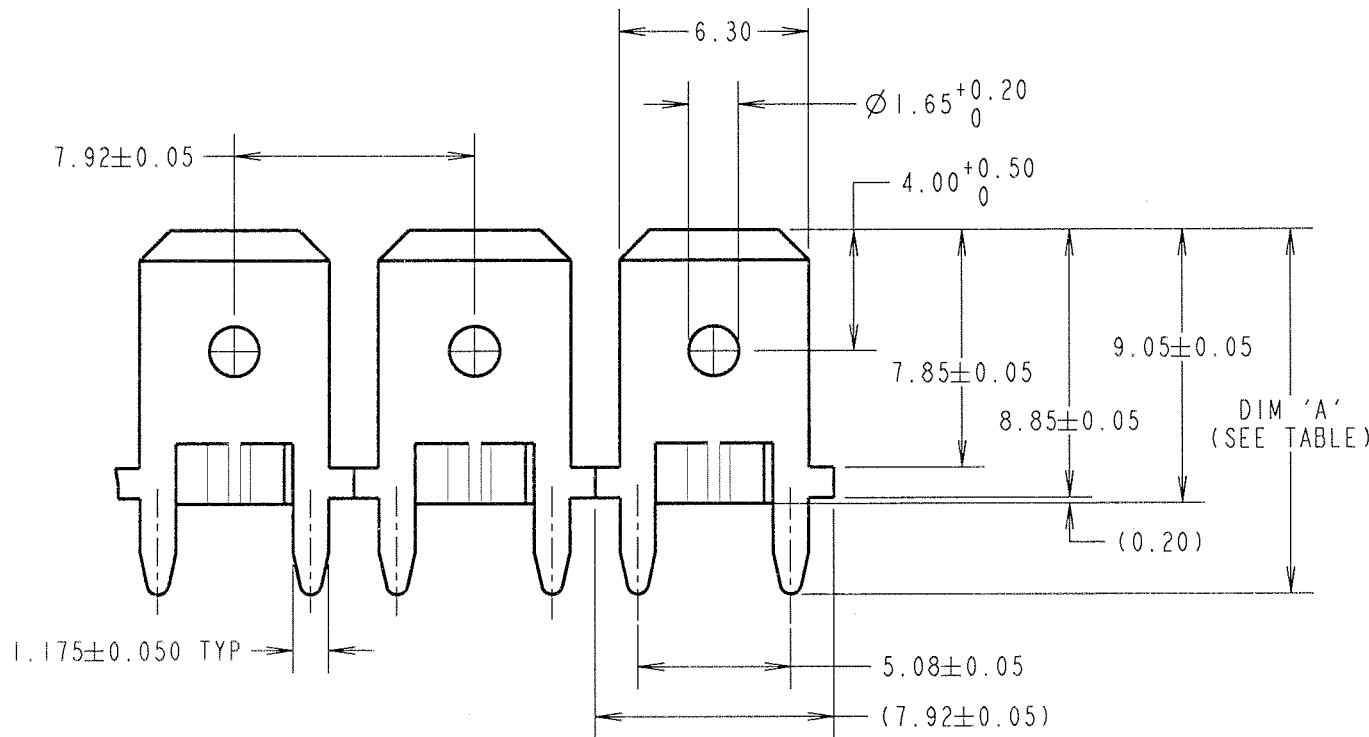
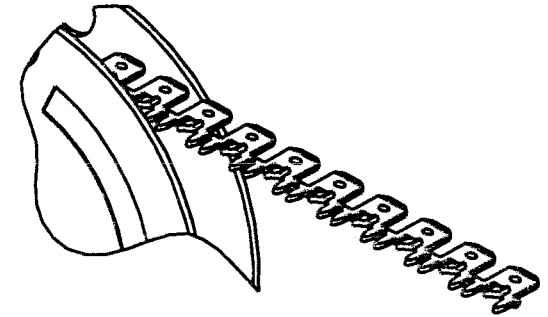

- NOTE:
- ANTI-ROCKING FEATURE.
 - QUANTITY OF TABS PER COIL = 10K.
TOTAL WEIGHT PER COIL = 6.153kg.
 - RECOMMENDED MOUNTING HOLE SIZE = $\varnothing 1.25 \pm 0.06$ mm.

PART No.	DIM 'A'	PCB THICKNESS
S405-XX	12.05	1.60
S406-XX	12.85	2.40

ORDER CODE: **S4XX-XX**

TYPE 09 OR 10 (SEE TABLE)

FINISH: _____
 00 = UNPLATED
 06 = 4µ 90/10 TIN/LEAD

JMB	22	05.08.05	8665
NAME	ISS.	DATE	C/NOTE
APPROVED: <i>[Signature]</i>			
CHECKED: <i>[Signature]</i>			
DRAWN: T. SANDY			
CUSTOMER REF.:			
ASSEMBLY DRG:			

HARWIN

HARWIN INC U.S.A. TEL: (812) 542 2540 FAX: (812) 542 2541	HARWIN PLC U.K. TEL: 023 9231 4545 FAX: 023 9231 4590	HARWIN PTE SINGAPORE TEL: 65 6779 4909 FAX: 65 6779 3868
--	--	---

THIS DRAWING AND ANY INFORMATION OR DESCRIPTIVE MATTER SET OUT HEREON ARE CONFIDENTIAL AND COPYRIGHT PROPERTY OF THE HARWIN GROUP AND MUST NOT BE DISCLOSED, LOANED, COPIED OR USED FOR MANUFACTURING, TENDERING OR FOR ANY OTHER PURPOSE WITHOUT THEIR WRITTEN PERMISSION.

TOLERANCES
 X. = ± 1 mm
 X.X = ± 0.25 mm
 X.XX = ± 0.10 mm
 X.XXX = ± 0.01 mm
 ANGLES = $\pm 5^\circ$
 UNLESS STATED

MATERIAL:
 BRASS CW508L H150
 TO BS EN 1652 (CuZn37 HARD)

FINISH: SEE ABOVE

S/AREA: mm²

TITLE:
 6.3mm BLADE VERTICAL
 REELED TAB TERMINAL

DRAWING NUMBER:
S409-XX / S410-XX

Customer Information Sheet

DRAWING No.: S409-XX / S410-XX SHEET 4 OF 4 IF IN DOUBT - ASK (C) NOT TO SCALE THIRD ANGLE PROJECTION ALL DIMENSIONS IN ~~mm~~ INCHES

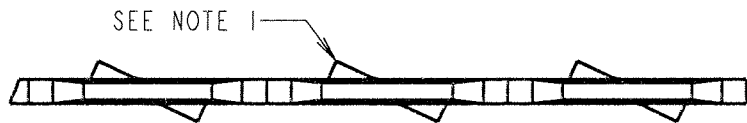

COMPONENTS SHOWN REELED
READY FOR INSERTION

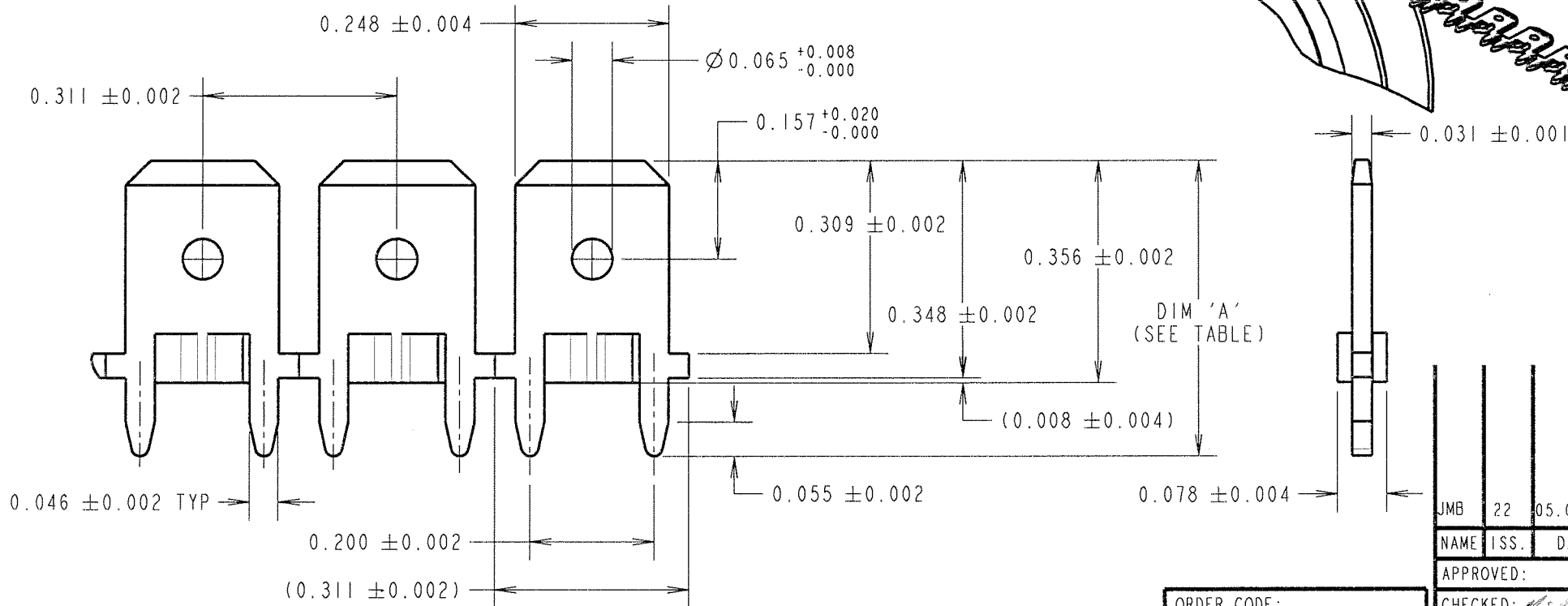
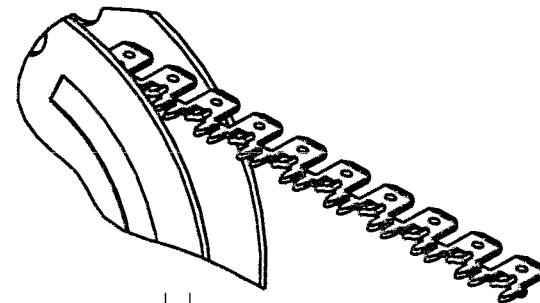

- NOTE:
- ANTI-ROCKING FEATURE.
 - QUANTITY OF TABS PER COIL = 10K.
TOTAL WEIGHT PER COIL = 6.153kg.
 - RECOMMENDED MOUNTING HOLE SIZE = $\varnothing 0.049 \pm 0.0024$ ".

PART No.	DIM 'A'	PCB THICKNESS
S405-XX	0.475	0.063
S406-XX	0.506	0.094

ORDER CODE:
S4XX-XX
TYPE 09 OR 10
(SEE TABLE)
FINISH:
00 = UNPLATED
06 = 90/10 TIN/LEAD

JMB	22	05.08.05	8665
NAME	ISS.	DATE	C/NOTE
APPROVED: <i>[Signature]</i>			
CHECKED: <i>[Signature]</i>			
DRAWN: I. SANDY			
CUSTOMER REF.:			
ASSEMBLY DRG:			

HARWIN

THIS DRAWING AND ANY INFORMATION OR DESCRIPTIVE MATTER SET OUT HEREON ARE CONFIDENTIAL AND COPYRIGHT PROPERTY OF THE HARWIN GROUP AND MUST NOT BE DISCLOSED, LOANED, COPIED OR USED FOR MANUFACTURING, TENDERING OR FOR ANY OTHER PURPOSE WITHOUT THEIR WRITTEN PERMISSION.

TOLERANCES
~~X = ± 1mm~~
~~X.X = ± 0.25mm~~
~~X.XX = ± 0.10mm~~
~~X.XXX = ± 0.01mm~~
 ANGLES = ± 5°
 UNLESS STATED

MATERIAL:
BRASS CW508L H150
TO BS EN 1652 (CuZn37 HARD)
FINISH: SEE ABOVE
S/AREA: mm²

TITLE:
6.3mm BLADE VERTICAL
REELED TAB TERMINAL
DRAWING NUMBER:
S409-XX / S410-XX

HARWIN INC U.S.A. TEL: (812) 542 2540 FAX: (812) 542 2541	HARWIN PLC U.K. TEL: 023 9231 4545 FAX: 023 9231 4590	HARWIN PTE SINGAPORE TEL: 65 6779 4909 FAX: 65 6779 3868
---	---	--