

Am25LS2513

Three-State Priority Encoder

Am25LS2513

DISTINCTIVE CHARACTERISTICS

- Encodes eight lines to three-line binary
- Expandable
- Cascadable
- Three State inverted output version of Am54LS/74LS/25LS148
- Gated three-state output
- Advanced Low-Power Schottky processing

GENERAL DESCRIPTION

The Am25LS2513 Low-Power Schottky Priority Encoder performs priority encoding of 8 inputs to provide a binary-weighted code of the priority order of the 3 tri-state active HIGH outputs A_0 , A_1 , A_2 . Three active LOW and two active HIGH inputs in AND-OR configuration allow control of the tri-state outputs. The use of the input enable (\bar{E}) combined

with the enable output ($\bar{E}O$) permits cascading without additional circuitry. Enable input ($\bar{E}I$) HIGH will force all outputs LOW subject to the tri-state control. The enable output is LOW when all inputs \bar{I}_0 through \bar{I}_7 are HIGH and the enable input is LOW.

BLOCK DIAGRAM

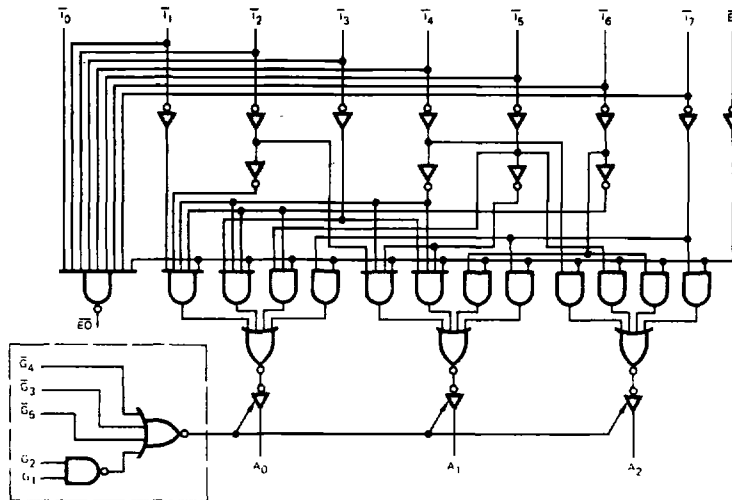

BD001660

RELATED PRODUCTS

Part No.	Description
Am2913	Priority Interrupt Expander
Am2914	Vectored Priority Interrupt Controller

9

CONNECTION DIAGRAM Top View

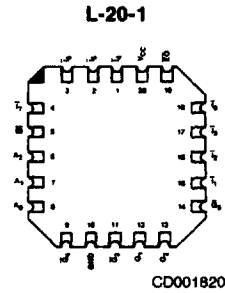
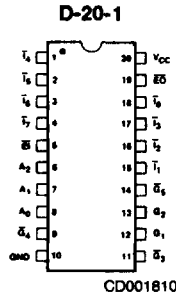

Note: Pin 1 is marked for orientation

LOGIC SYMBOL

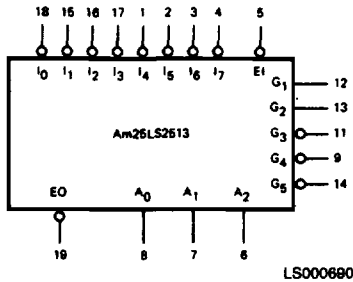

METALLIZATION AND PAD LAYOUT

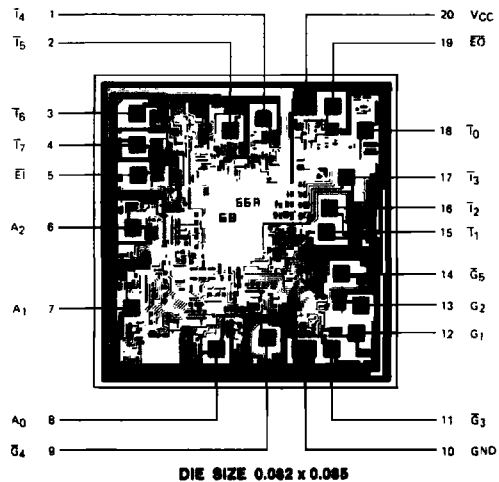

ORDERING INFORMATION

AMD products are available in several packages and operating ranges. The order number is formed by a combination of the following: Device number, speed option (if applicable), package type, operating range and screening option (if desired).

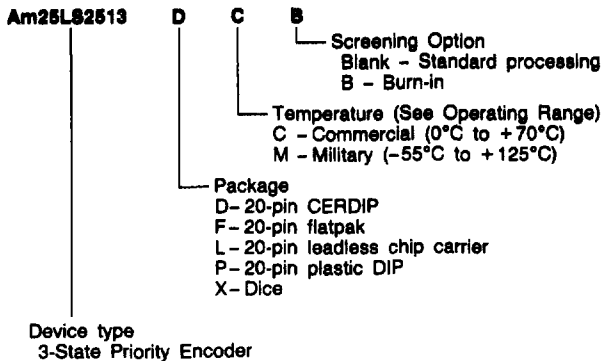

Valid Combinations	
Am25LS2513	PC
	DC, DM
	FM
	LC, LM
	XC, XM

Valid Combinations
Consult the AMD sales office in your area to determine if a device is currently available in the combination you wish.

PIN DESCRIPTION

Pin No.	Name	I/O	Description
8, 7, 6	A0, A1, A2	O	Three-state, active high encoder outputs.
5	$\overline{E}I$	I	Enable input provided to allow cascaded operation.
19	$\overline{E}O$	O	Enable output provided to enable the next lower order priority chip.
12, 13	G ₁ , G ₂	O	Active high three-state output controls.
11, 9, 14	$\overline{G}_3, \overline{G}_4, \overline{G}_5$	O	Active low three-state output controls.
18,15,16, 17,1,2,3,4	\overline{I}_0-7	I	Active low encoder inputs.

TRUTH TABLES

Inputs								Outputs				
$\overline{E}I$	\overline{I}_0	\overline{I}_1	\overline{I}_2	\overline{I}_3	\overline{I}_4	\overline{I}_5	\overline{I}_6	\overline{I}_7	A ₀	A ₁	A ₂	$\overline{E}O$
H	X	X	X	X	X	X	X	X	L	L	L	H
L	H	H	H	H	H	H	H	H	L	L	L	L
L	X	X	X	X	X	X	X	L	H	H	H	H
L	X	X	X	X	X	X	L	H	L	H	H	H
L	X	X	X	X	L	H	H	H	H	L	H	H
L	X	X	X	L	H	H	H	H	H	H	L	H
L	X	X	L	H	H	H	H	H	L	H	L	H
L	X	L	H	H	H	H	H	H	H	L	L	H
L	L	H	H	H	H	H	H	H	L	L	L	H

G ₁	G ₂	\overline{G}_3	\overline{G}_4	\overline{G}_5	A ₀	A ₁	A ₂
H	H	L	L	L	Enabled		
L	X	X	X	X	Z	Z	Z
X	L	X	X	X	Z	Z	Z
X	X	H	X	X	Z	Z	Z
X	X	X	H	X	Z	Z	Z
X	X	X	X	H	Z	Z	Z

Z = HIGH Impedance

H = HIGH Voltage Level
 L = LOW Voltage Level
 X = Don't Care
 For G₁ = H, G₂ = H, G₃ = L, G₄ = L, G₅ = L

**PRIORITY ENCODED RST INTERRUPT
INSTRUCTION FOR THE Am9080A**

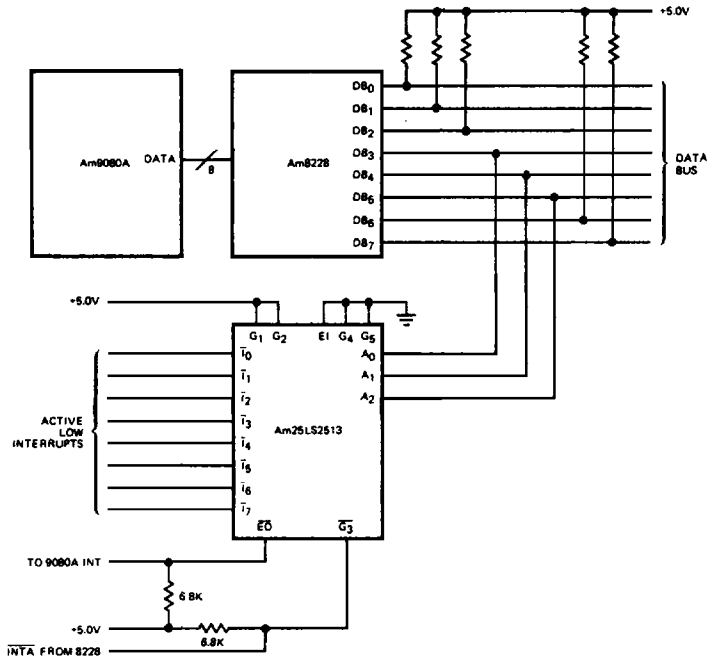

AF001070

APPLICATION

Am25LS2513

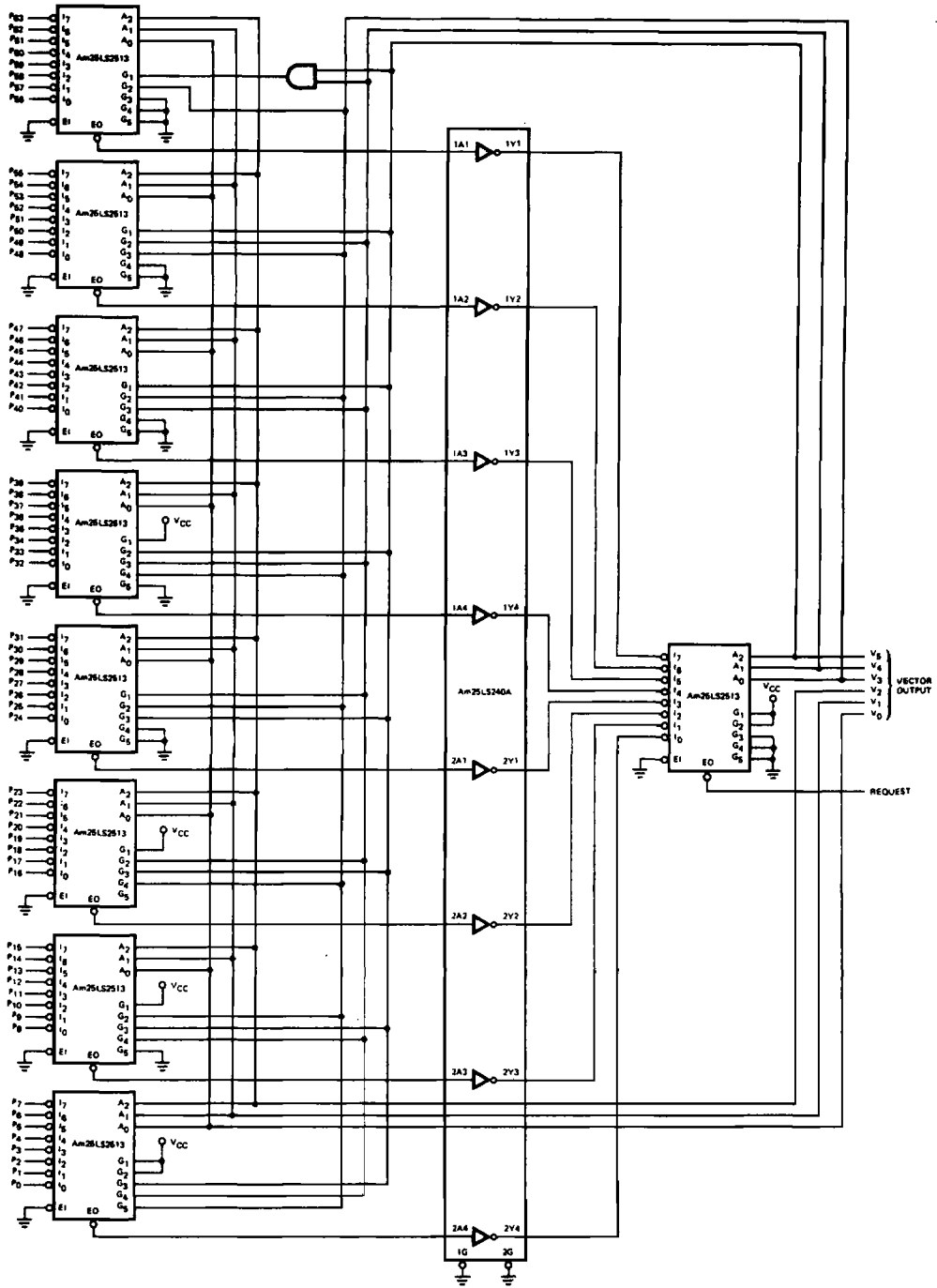

9

64 Input Priority Encoder Connected for Parallel Enable

AF001140

ABSOLUTE MAXIMUM RATINGS

Storage Temperature	-65°C to +150°C
(Ambient) Temperature Under Bias	-55°C to +125°C
Supply Voltage to Ground Potential	
Continuous	-0.5V to +7.0V
DC Voltage Applied to Outputs For	
High Output State	-0.5V to +V _{CC} max
DC Input Voltage	-0.5V to +7.0V
DC Output Current, into Outputs	30mA
DC Input Current	-30mA to +5.0mA

Stresses above those listed under ABSOLUTE MAXIMUM RATINGS may cause permanent device failure. Functionality at or above these limits is not implied. Exposure to absolute maximum ratings for extended periods may affect device reliability.

OPERATING RANGES

Commercial (C) Devices	
Temperature	0°C to +70°C
Supply Voltage	+4.75V to +5.25V
Military (M) Devices	
Temperature	-55°C to +125°C
Supply Voltage	+4.5V to +5.5V

Operating ranges define those limits over which the functionality of the device is guaranteed.

DC CHARACTERISTICS over operating range unless otherwise specified

Parameters	Description	Test Conditions (Note 2)	Min	Typ (Note 1)	Max	Units	
V _{OH}	Output HIGH Voltage	V _{CC} = MIN. V _{IN} = V _{IH} or V _{IL}	A _i	MIL, I _{OH} = -1.0mA	2.4	3.4	Volts
				COM'L, I _{OH} = -2.6mA	2.4	3.2	
			E _O , I _{OH} = -440μA	MIL	2.5	3.4	
				COM'L	2.7	3.4	
V _{OL}	Output LOW Voltage	V _{CC} = MIN. V _{IN} = V _{IH} or V _{IL}	I _{OL} = 4.0mA			0.4	Volts
			I _{OL} = 8.0mA			0.45	
			I _{OL} = 12mA(A _n Outputs)			0.5	
V _{IH}	Input HIGH Level	Guaranteed input logical HIGH voltage for all inputs	2.0			Volts	
V _{IL}	Input LOW Level	Guaranteed input logical LOW voltage for all inputs	MIL		0.7	Volts	
			COM'L		0.8		
V _I	Input Clamp Voltage	V _{CC} = MIN., I _{IN} = -18mA			-1.5	Volts	
I _{IL}	Input LOW Current	V _{CC} = MAX. V _{IN} = 0.4V	ET, G ₁ , G ₂ , G ₃ , G ₄ , G ₅ , I ₀			-0.4	mA
			All others			-0.8	
I _{IH}	Input HIGH Current	V _{CC} = MAX. V _{IN} = 2.7V	ET, G ₁ , G ₂ , G ₃ , G ₄ , G ₅ , I ₀			20	μA
			All others			40	
I _I	Input HIGH Current	V _{CC} = MAX. V _{IN} = 7.0V	ET, G ₁ , G ₂ , G ₃ , G ₄ , G ₅ , I ₀			0.1	mA
			All others			0.2	
I _O	Off-State (High Impedance) Output Current	V _{CC} = MAX.	V _O = 0.4V			-20	μA
			V _O = 2.4V			20	
I _{SC}	Output Short Circuit Current (Note 3)	V _{CC} = MAX.	-15		-85	mA	
I _{CC}	Power Supply Current (Note 4)	V _{CC} = MAX.		15	24	mA	

Notes: 1. Typical limits are at V_{CC} = 5.0V, 25°C ambient and maximum loading.

2. For conditions shown as MIN. or MAX., use the appropriate value specified under Operating Ranges for the applicable device type.

3. Not more than one output should be shorted at a time. Duration of the short circuit test should not exceed one second.

4. All inputs and outputs open.

SWITCHING CHARACTERISTICS ($T_A = +25^\circ\text{C}$, $V_{CC} = 5.0\text{V}$)

Parameters	Description	Test Conditions	Min	Typ	Max	Units
t_{PLH}	I_i to A_n (In-phase)	$C_L = 15\text{pF}$ $R_L = 2.0\text{k}\Omega$		17	25	ns
t_{PHL}				17	25	
t_{PLH}	I_i to A_n (Out-phase)			11	17	ns
t_{PHL}				12	18	
t_{PLH}	I_i to $E\bar{O}$			7.0	11	ns
t_{PHL}				24	36	
t_{PLH}	$E\bar{I}$ to $E\bar{O}$			11	17	ns
t_{PHL}				23	34	
t_{PLH}	$E\bar{I}$ to A_n			12	18	ns
t_{PHL}				14	21	
t_{ZH}	G_1 or G_2 to A_n			23	40	ns
t_{ZL}				20	37	
t_{ZH}	$\bar{G}_3, \bar{G}_4, \bar{G}_5$ to A_n			20	30	ns
t_{ZL}				18	27	
t_{HZ}	G_1 or G_2 to A_n	$C_L = 5.0\text{pF}$ $R_L = 2.0\text{k}\Omega$		17	27	ns
t_{LZ}				19	28	
t_{HZ}	$\bar{G}_3, \bar{G}_4, \bar{G}_5$ to A_n			16	24	ns
t_{LZ}				18	27	

SWITCHING CHARACTERISTICS over operating range unless otherwise specified*

Parameters	Description	Test Conditions	Am25LS COMMERCIAL		Am25LS MILITARY		Units
			Min	Max	Min	Max	
t_{PLH}	I_i to A_n (In-phase)	$C_L = 50\text{pF}$ $R_L = 2.0\text{k}\Omega$		31		37	ns
t_{PHL}				30		34	
t_{PLH}	I_i to A_n (Out-phase)			22		27	ns
t_{PHL}				22		25	
t_{PLH}	I_i to $E\bar{O}$			15		18	ns
t_{PHL}				48		60	
t_{PLH}	$E\bar{I}$ to $E\bar{O}$			19		21	ns
t_{PHL}				46		57	
t_{PLH}	$E\bar{I}$ to A_n			22		25	ns
t_{PHL}				27		32	
t_{ZH}	G_1 or G_2 to A_n			42		49	ns
t_{ZL}				43		49	
t_{ZH}	$\bar{G}_3, \bar{G}_4, \bar{G}_5$ to A_n			38		43	ns
t_{ZL}				35		43	
t_{HZ}	G_1 or G_2 to A_n	$C_L = 5.0\text{pF}$ $R_L = 2.0\text{k}\Omega$		34		40	ns
t_{LZ}				34		40	
t_{HZ}	$\bar{G}_3, \bar{G}_4, \bar{G}_5$ to A_n			30		35	ns
t_{LZ}				31		35	

*AC performance over the operating temperature range is guaranteed by testing defined in Group A, Subgroup B.

Note: $l = 0$ to 7
 $n = 0$ to 2

Am25LS LOW-POWER SCHOTTKY INPUT/OUTPUT CURRENT INTERFACE CONDITIONS

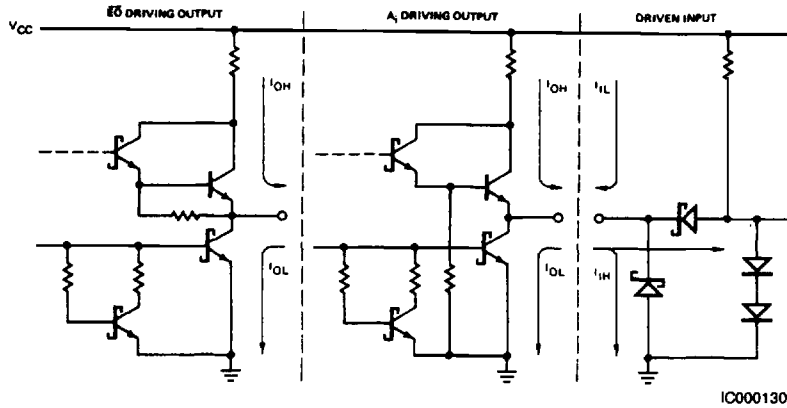

Note: Actual current flow direction shown.