

Philips Components—Signetics

Document No.	853-0641
ECN No.	99799
Date of Issue	June 14, 1990
Status	Product Specification
ECL Products	

# 10105

## Gate

Triple 2-3-2 Input OR/NOR Gate

**FEATURES**

- Typical propagation delay: 2.0ns
- Typical supply current ( $-I_{EE}$ ): 17mA

**DESCRIPTION**

The 10105 is a Triple 2-3-2 Input OR/NOR Gate.

All unused inputs can be left open due to integrated pull-down resistors which avoid the need for a supply voltage.

**ORDERING INFORMATION**

DESCRIPTION	ORDER CODE
16-Pin Plastic DIP	10105N
16-Pin Ceramic DIP	10105F

**PIN DESCRIPTION**

PINS	DESCRIPTION
$D_0 - D_6$	Data Inputs
$Q_0, Q_2, Q_4$	Data Outputs (OR)
$\bar{Q}_1, \bar{Q}_3, \bar{Q}_5$	Data Outputs (NOR)

**PIN CONFIGURATION**

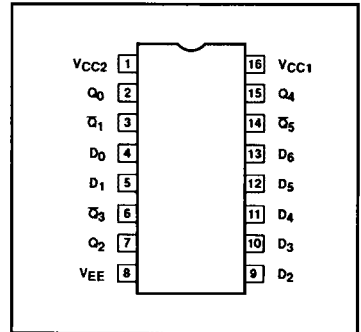

**LOGIC DIAGRAM**

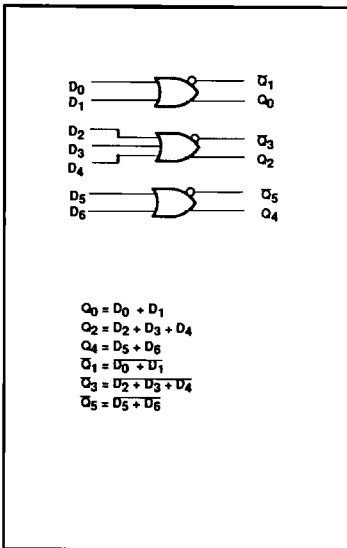

**SIMPLIFIED SCHEMATIC**

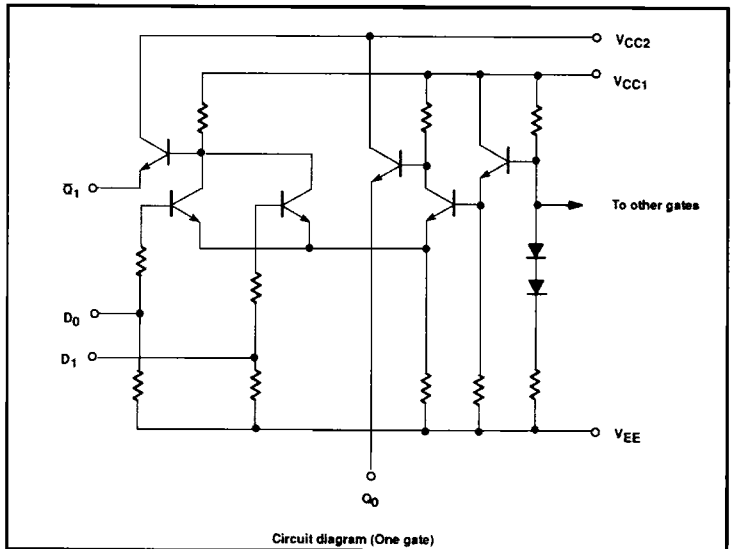

## Gate

10105

## ABSOLUTE MAXIMUM RATINGS

SYMBOL	PARAMETER	LIMITS	UNIT	
$V_{EE}$	Supply voltage	-8.0	V	
$V_{IN}$	Input voltage ( $V_{IN}$ should never be more negative than $V_{EE}$ )	0 to $V_{EE}$	V	
$I_O$	Output source current (continuous)	-50	mA	
$T_S$	Storage temperature range	-55 to +150	°C	
$T_J$	Maximum junction temperature	Ceramic Package	+165	°C
		Plastic Package	+150	°C

## NOTE:

Operation beyond the limits set forth in this table may impair the useful life of the device. Unless otherwise noted, these limits are specified over the operating ambient temperature range.

## DC OPERATING CONDITIONS

SYMBOL	PARAMETER	TEST CONDITIONS	LIMITS			UNIT
			MIN.	NOM.	MAX.	
$V_{CC1}, V_{CC2}$	Circuit ground		0	0	0	V
$V_{EE}$	Supply voltage (negative)			-5.2		V
$V_{IH}$	High level input voltage	$T_A = -30^\circ\text{C}$			-890	mV
		$T_A = +25^\circ\text{C}$			-810	mV
		$T_A = +85^\circ\text{C}$			-700	mV
$V_{IHT}$	High level input threshold voltage	$T_A = -30^\circ\text{C}$	-1205			mV
		$T_A = +25^\circ\text{C}$	-1105			mV
		$T_A = +85^\circ\text{C}$	-1035			mV
$V_{ILT}$	Low level input threshold voltage	$T_A = -30^\circ\text{C}$			-1500	mV
		$T_A = +25^\circ\text{C}$			-1475	mV
		$T_A = +85^\circ\text{C}$			-1440	mV
$V_{IL}$	Low level input voltage	$T_A = -30^\circ\text{C}$	-1890			mV
		$T_A = +25^\circ\text{C}$	-1850			mV
		$T_A = +85^\circ\text{C}$	-1825			mV
$T_A$	Operating ambient temperature range		-30	+25	+85	°C

## NOTE:

When operating at other than the specified  $V_{EE}$  voltage (-5.2V), the DC and AC Electrical Characteristics will vary slightly from specified values.

## Gate

10105

**DC ELECTRICAL CHARACTERISTICS**  $V_{CC1} = V_{CC2} = \text{ground}$ ,  $V_{EE} = -5.2V \pm 0.010V$ ,  $T_A = -30^\circ\text{C}$  to  $+85^\circ\text{C}$  output loading  $50\Omega$  to  $-2.0V \pm 0.010V$  unless otherwise specified<sup>1,3</sup>

SYMBOL	PARAMETER	TEST CONDITIONS <sup>2</sup>		LIMITS			UNIT
				MIN.	TYP.	MAX.	
$V_{OH}$	High level output voltage	$T_A = -30^\circ\text{C}$	For $Q_n$ outputs, apply $V_{IHMAX}$ to all inputs. For $\bar{Q}_n$ outputs, apply $V_{ILMIN}$ to all inputs.	-1060		-890	mV
		$T_A = +25^\circ\text{C}$		-960		-810	mV
		$T_A = +85^\circ\text{C}$		-890		-700	mV
$V_{OHT}$	High level output threshold voltage	$T_A = -30^\circ\text{C}$	For $Q_n$ outputs, apply $V_{IHT}$ to each input, one at a time, w/ $V_{ILMIN}$ applied to all other inputs. For $\bar{Q}_n$ outputs, apply $V_{ILT}$ to each input w/ $V_{ILMIN}$ applied to all other inputs.	-1080			mV
		$T_A = +25^\circ\text{C}$		-980			mV
		$T_A = +85^\circ\text{C}$		-910			mV
$V_{OLT}$	Low level output threshold voltage	$T_A = -30^\circ\text{C}$	For $Q_n$ outputs, apply $V_{ILT}$ to each input, one at a time, w/ $V_{ILMIN}$ applied to all other inputs. For $\bar{Q}_n$ outputs, apply $V_{IHT}$ to each input w/ $V_{ILMIN}$ applied to all other inputs.			-1655	mV
		$T_A = +25^\circ\text{C}$				-1630	mV
		$T_A = +85^\circ\text{C}$				-1595	mV
$V_{OL}$	Low level output voltage	$T_A = -30^\circ\text{C}$	For $Q_n$ outputs, apply $V_{ILMIN}$ to all inputs. For $\bar{Q}_n$ outputs, apply $V_{IHMAX}$ to all inputs.	-1890		-1675	mV
		$T_A = +25^\circ\text{C}$		-1850		-1650	mV
		$T_A = +85^\circ\text{C}$		-1825		-1615	mV
$I_{IH}$	High level input current	$T_A = -30^\circ\text{C}$	Apply $V_{IHMAX}$ to each input under test, one at a time, with $V_{ILMIN}$ applied to all other inputs.			425	$\mu\text{A}$
		$T_A = +25^\circ\text{C}$				265	$\mu\text{A}$
		$T_A = +85^\circ\text{C}$				265	$\mu\text{A}$
$I_{IL}$	Low level input current	$T_A = -30^\circ\text{C}$	Apply $V_{ILMIN}$ to each input under test, one at a time, with $V_{IHMAX}$ applied to all other inputs.	0.5			$\mu\text{A}$
		$T_A = +25^\circ\text{C}$		0.5			$\mu\text{A}$
		$T_A = +85^\circ\text{C}$		0.3			$\mu\text{A}$
$-I_{EE}$	$V_{EE}$ supply current	$T_A = -30^\circ\text{C}$				23	mA
		$T_A = +25^\circ\text{C}$			17	21	mA
		$T_A = +85^\circ\text{C}$				23	mA
$\frac{\Delta V_{OH}}{\Delta V_{EE}}$	High level output voltage compensation	$T_A = +25^\circ\text{C}$			0.016		V/V
$\frac{\Delta V_{OL}}{\Delta V_{EE}}$	Low level output voltage compensation				0.250		V/V
$\frac{\Delta V_{BB}}{\Delta V_{EE}}$	Reference bias voltage compensation				0.148		V/V

**NOTES:**

- The specified limits represent the worst case values for the parameter. Since these worst case values normally occur at the supply voltage and temperature extremes, additional noise immunity can be achieved by decreasing the allowable operating condition ranges.
- Conditions for testing shown in the tables are not necessarily worst case. For worst case testing guidelines, refer to DC Testing, Chapter 1, Section 3.
- The specified limits shown in the DC Electrical Characteristics table can be met only after thermal equilibrium has been established. Thermal equilibrium is established by applying power for at least 2 minutes, while maintaining transverse airflow of 2.5 meters/sec (500 linear feet/min) over the device, mounted either in a test socket or on a printed circuit board. Test voltage values are given in the DC Operating Conditions table.

Gate

10105

AC ELECTRICAL CHARACTERISTICS  $V_{CC1} = V_{CC2} = \text{ground}, V_{EE} = -5.2V \pm 0.010V$

SYMBOL	PARAMETER	TEST CONDITION	LIMITS						UNIT	
			$T_A = -30^\circ\text{C}$		$T_A = +25^\circ\text{C}$			$T_A = +85^\circ\text{C}$		
			MIN.	MAX.	MIN.	TYP.	MAX.	MIN.		MAX.
$t_{PLH}$ $t_{PHL}$	Propagation delay $D_n$ to $Q_n, \bar{Q}_n$	Waveform 1	1.00 1.00	3.10 3.10	1.00 1.00	2.00 2.00	2.90 2.90	1.00 1.00	3.30 3.30	ns ns
$t_{TLH}$ $t_{THL}$	Transition time 20% to 80%, 80% to 20%	Waveform 1	1.10 1.10	3.60 3.60	1.10 1.10	2.00 2.00	3.30 3.30	1.10 1.10	3.70 3.70	ns ns

NOTE:

For AC test setup information, see AC Testing, Chapter 2, Section 3.

AC WAVEFORMS

