



V826764B24SB
512 MB 200-PIN DDR UNBUFFERED SODIMM
64M x 64

Features

- JEDEC 200 Pin DDR Unbuffered Small-Outline, Dual In-Line memory module (SODIMM); 67,108,864 x 64 bit organization.
- Utilizes High Performance 32M x 16 DDR SDRAM in TSOP-II Packages
- Single +2.5V ($\pm 0.2V$) Power Supply
- Single +2.6V ($\pm 0.1V$) Power Supply for DDR400
- Programmable CAS Latency, Burst Length, and Wrap Sequence (Sequential & Interleave)
- Auto Refresh (CBR) and Self Refresh
- All Inputs, Outputs are SSTL-2 Compatible
- 8192 Refresh Cycles every 64 ms
- Serial Presence Detect (SPD)

Description

The V826764B24SB memory module is organized 67,108,864 x 64 bits in a 200 pin memory module. The 64M x 64 memory module uses 8 ProMOS 32M x 16 DDR SDRAM. The x64 modules are ideal for use in high performance computer systems where increased memory density and fast access times are required.

	Module Speed	D3	C0	Units
	Clock Frequency (max.)	200 (PC400B)	166 (PC333)	MHz
t _{CK}	Clock Cycle Time $\overline{\text{CAS}}$ Latency = 3	5	-	ns
	Clock Cycle Time $\overline{\text{CAS}}$ Latency = 2.5	6	6	ns
t _{RCD}	t _{RCD} parameter	3	3	CLK
t _{RP}	t _{RP} parameter	3	3	CLK

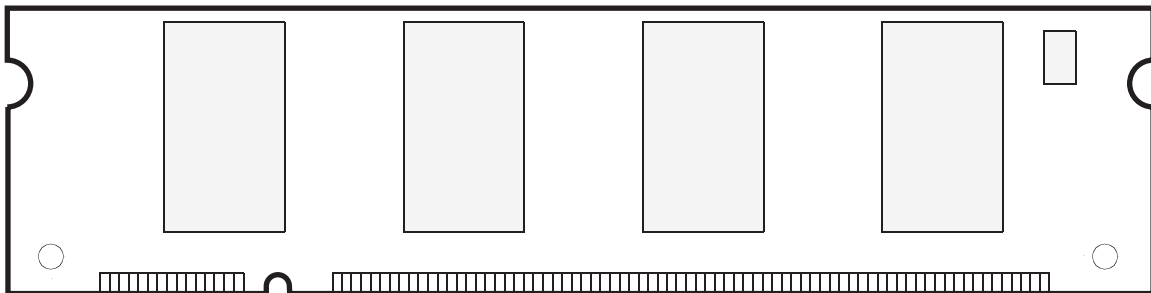

Part Number Information

1	2	3	4	5	6	7	8	9	10	11	12	13	14	15	16	17
V	8	2	6	7	6	4	B	2	4	S	B	I	W	-	D	3

ProMOS	DATA DEPTH 16 : 16Mb 32 : 32 Mb 64 : 64 Mb 65 : 128 Mb 66 : 256 Mb	REFRESH RATE 0: 4K 2: 8K	COMPONENT REV LEVEL	PCB TYPE G : GOLD_LEAD PLATING W : GOLD_RoHS L : LOW PROFILE_LEAD PLATING X : LOW PROFILE_RoHS																			
TYPE 8 : DDR	DATA WIDTH & COMP DENSITY 65 X64 using 128M 66 X64 using 256M 67 X64 using 512M 68 X64 using 1G 69 X64 using 2G 73 X72 using 128M 74 X72 using 256M 75 X72 using 512M 76 X72 using 1G 77 X72 using 2G	BANKS 4 : 4 Banks	COMPONENT PKG																				
VOLTAGE 2 : 2.5V	MODULE TYPE & COMP WIDTH		<table border="1"> <tr> <th>LEAD PLATING</th> <th>GREEN</th> <th>PACKAGE DESCRIPTION</th> </tr> <tr> <td>T</td> <td>I</td> <td>TSOP</td> </tr> <tr> <td>S</td> <td>J</td> <td>FBGA</td> </tr> <tr> <td>D</td> <td>N</td> <td>Die-stacked TSOP</td> </tr> <tr> <td>Z</td> <td>P</td> <td>Die-stacked FBGA</td> </tr> </table>	LEAD PLATING	GREEN	PACKAGE DESCRIPTION	T	I	TSOP	S	J	FBGA	D	N	Die-stacked TSOP	Z	P	Die-stacked FBGA					
LEAD PLATING	GREEN	PACKAGE DESCRIPTION																					
T	I	TSOP																					
S	J	FBGA																					
D	N	Die-stacked TSOP																					
Z	P	Die-stacked FBGA																					
	<table border="1"> <thead> <tr> <th>BASED ON</th> <th>X4</th> <th>X16</th> <th>X8</th> </tr> </thead> <tbody> <tr> <td>184PIN DIMM UNBUFFERED</td> <td>I</td> <td>J</td> <td>K</td> </tr> <tr> <td>184PIN DIMM REGISTERED</td> <td>N</td> <td>O</td> <td>U</td> </tr> <tr> <td>200PIN SO-DIMM</td> <td>V</td> <td>B</td> <td>G</td> </tr> <tr> <td>172PIN Micro-DIMM</td> <td></td> <td></td> <td>M</td> </tr> </tbody> </table>	BASED ON	X4	X16	X8	184PIN DIMM UNBUFFERED	I	J	K	184PIN DIMM REGISTERED	N	O	U	200PIN SO-DIMM	V	B	G	172PIN Micro-DIMM			M	I/O INTERFACE S: SSTL_2	SPEED B0 : PC2100B (133MHz @CL2.5-3-3) B1 : PC2100A (133MHz @CL2-2-2) C0 : PC2700 (166MHz @CL2.5-3-3) D0 : PC3200 (200MHz @CL2.5-3-3) D3 : PC3200 (200MHz @CL3-3-3)
BASED ON	X4	X16	X8																				
184PIN DIMM UNBUFFERED	I	J	K																				
184PIN DIMM REGISTERED	N	O	U																				
200PIN SO-DIMM	V	B	G																				
172PIN Micro-DIMM			M																				

*RoHS: Restriction of Hazardous Substances
*GREEN: RoHS-compliant and Halogen-Free

Block Diagram

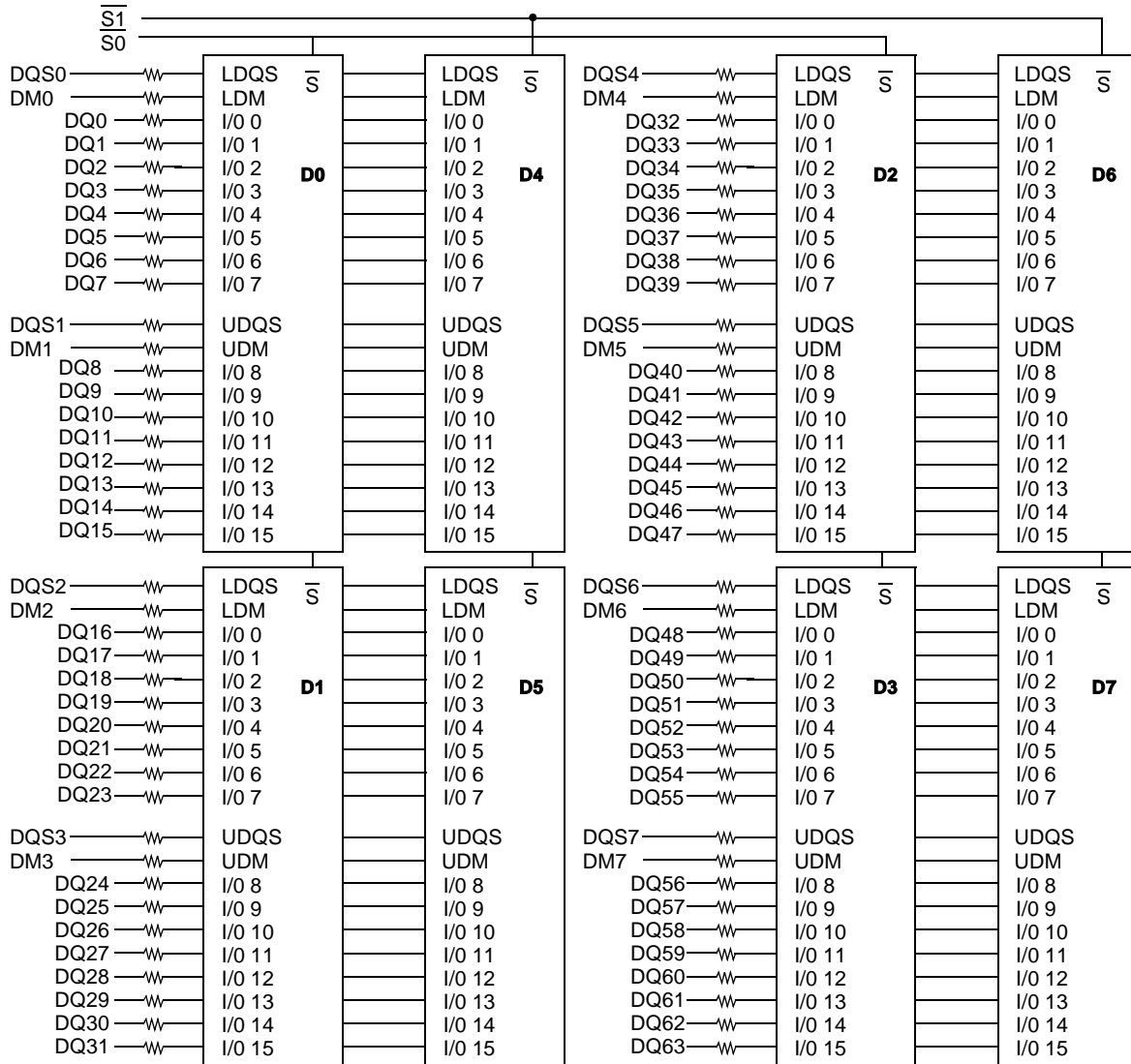

- BA0 - BA1 → BA0-BA1: DDR SDRAMs D0 - D7
- A0-A12 → A0-A12: SDRAMs D0 - D7
- RAS → RAS: SDRAMs D0 - D7
- CAS → CAS: SDRAMs D0 - D7
- CKE0 → CKE: SDRAMs D0 - D7
- WE → WE: SDRAMs D0 - D7

Clock Wiring	
Clock Input	SDRAMs
CK0/CK0	4 SDRAMs
CK1/CK1	4 SDRAMs
CK2/CK2	NC

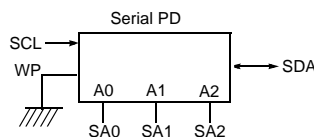
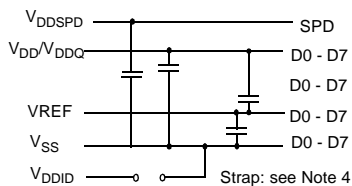
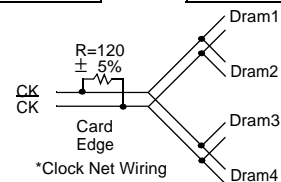

- Notes:
1. DQ-to-I/O wiring is shown as recommended but may be changed.
 2. DQ/DQS/DM/CKE/CS relationships must be maintained as shown.
 3. DQ, DQS, DM/DQS resistors: 22 Ohms.
 4. VDDID strap connections (for memory device VDD, VDDQ):
 STRAP OUT (OPEN): VDD = VDDQ
 STRAP IN (VSS): VDD = VDDQ.

Pin Configurations (Front Side/Back Side)

Pin	Front	Pin	Front	Pin	Front	Pin	Back	Pin	Back	Pin	Back
1	VREF	67	DQ27	135	DQ34	2	VREF	68	DQ31	136	DQ38
3	VSS	69	VDD	137	VSS	4	VSS	70	VDD	138	VSS
5	DQ0	71	CB0	139	DQ35	6	DQ4	72	CB4	140	DQ39
7	DQ1	73	CB1	141	DQ40	8	DQ5	74	CB5	142	DQ44
9	VDD	75	VSS	143	VDD	10	VDD	76	VSS	144	VDD
11	DQS0	77	DQS8	145	DQ41	12	DM0	78	DM8	146	DQ45
13	DQ2	79	CB2	147	DQS5	14	DQ6	80	CB6	148	DM5
15	VSS	81	VDD	149	VSS	16	VSS	82	VDD	150	VSS
17	DQ3	83	CB3	151	DQ42	18	DQ7	84	CB7	152	DQ46
19	DQ8	85	DU	153	DQ43	20	DQ12	86	DU/(RESET)	154	DQ47
21	VDD	87	VSS	155	VDD	22	VDD	88	VSS	156	VDD
23	DQ9	89	CK2	157	VDD	24	DQ13	90	VSS	158	CK1
25	DQS1	91	CK2	159	VSS	26	DM1	92	VDD	160	CK1
27	VSS	93	VDD	161	VSS	28	VSS	94	VDD	162	VSS
29	DQ10	95	CKE1	163	DQ48	30	DQ14	96	CKE0	164	DQ52
31	DQ11	97	DU	165	DQ49	32	DQ15	98	DU(BA2)	166	DQ53
33	VDD	99	A12	167	VDD	34	VDD	100	A11	168	VDD
35	CK0	101	A9	169	DQS6	36	VDD	102	A8	170	DM6
37	CK0	103	VSS	171	DQ50	38	VSS	104	VSS	172	DQ54
39	VSS	105	A7	173	VSS	40	VSS	106	A6	174	VSS
Key		107	A5	175	DQ51	Key		108	A4	176	DQ55
41	DQ16	109	A3	177	DQ56	42	DQ20	110	A2	178	DQ60
43	DQ17	111	A1	179	VDD	44	DQ21	112	A0	180	VDD
45	VDD	113	VDD	181	DQ57	46	VDD	114	VDD	182	DQ61
47	DQS2	115	A10/AP	183	DQS7	48	DM2	116	BA1	184	DM7
49	DQ18	117	BA0	185	DQ58	50	DQ22	118	RAS	186	VSS
51	VSS	119	WE	187	DQ58	52	VSS	120	CAS	188	DQ62
53	DQ19	121	S0	189	DQ59	54	DQ23	122	S1	190	DQ63
55	DQ24	123	DU	191	VDD	56	DQ28	124	DU	192	VDD
57	VDD	125	VSS	193	SDA	58	VDD	126	VSS	194	SA0
59	DQ25	127	DQ32	195	SCL	60	DQ29	128	DQ36	196	SA1
61	DQS3	129	DQ33	197	VDDSPD	62	DM3	130	DQ37	198	SA2
63	VSS	131	VDD	199	VDDID	64	VSS	132	VDD	200	DU
65	DQ26	133	DQS4			66	DQ30	134	DM4		

Notes:

* These pins are not used in this module.

Pin Names

Pin	Pin Description
A0~A12	Address Input (Multiplexed)
BA0~BA1	Bank Select Address
DQ0~DQ63	Data Input/Output
DQS0~DQS7	Data Strobe Input/Output
CK0~CK2, CK0~CK2,	Clock Input
CKE0	Clock Enable Input
S0, S1	Chip Select Input
RAS	Row Address Strobe
CAS	Column Address Strobe
WE	Write Enable
DM0~DM7	Data - In Mask

Pin	Pin Description
VDD	Power Supply
VDDQ	Power Supply for DQS
VSS	Ground
VREF	Power Supply for Reference
VDDSPD	Serial EEPROM Power Supply (2.3V to 3.6V)
SDA	Serial Data I/O
SCL	Serial Clock
SA0~2	Address in EEPROM
VDDID	VDD Identification Flag
NC	No Connection

Serial Presence Detect Information

Bin Sort:

D3 (PC3200 @ CL 3-3-3)

C0 (PC2700 @ CL 2.5-3-3)

Byte #	Function described	Function Supported		Hex value	
		D3	C0	D3	C0
0	Defines # of Bytes written into serial memory at module manufacturer	128bytes		80h	
1	Total # of Bytes of SPD memory device	256bytes		08h	
2	Fundamental memory type	SDRAM DDR		07h	
3	# of row address on this assembly	13		0Dh	
4	# of column address on this assembly	10		0Ah	
5	# of module Ranks on this assembly	2 Ranks		02h	
6	Data width of this assembly	64 bits		40h	
7Data width of this assembly	-		00h	
8	VDDQ and interface standard of this assembly	SSTL 2.5V		04h	
9	DDR SDRAM cycle time at highest CAS Latency	5ns	6ns	50h	60h
10	DDR SDRAM Access time from clock at highest CL	±0.65ns	±0.70ns	65h	70h
11	DIMM configuration type(Non-parity, Parity, ECC)	Non-parity, Non-ECC		00h	
12	Refresh rate & type	7.8us & Self refresh		82h	
13	Primary DDR SDRAM width	x16		10h	
14	Error checking DDR SDRAM data width	N/A		00h	
15	Minimum clock delay for back-to-back random column address	t _{CCD} =1CLK		01h	
16	DDR SDRAM device attributes : Burst lengths supported	2,4,8		0Eh	
17	DDR SDRAM device attributes : # of banks on each DDR SDRAM	4 banks		04h	
18	DDR SDRAM device attributes : CAS Latency supported	2.5(C0) 2.5, 3(D3)		08h	18h
19	DDR SDRAM device attributes : CS Latency	0CLK		01h	
20	DDR SDRAM device attributes : WE Latency	1CLK		02h	
21	DDR SDRAM module attributes	Differential clock / non Registered		20h	
22	DDR SDRAM device attributes : General	+/-0.2V voltage tolerance Concurrent Auto Precharge t _{RAS} Lock Out		C0h	
23	Min. Clock Cycle Time at second highest CL	6.0ns	-	60h	00h
24	Max. Data Access time from clock at second highest CL	±0.70ns	-	70h	00h
25	Min. Clock Cycle Time at third highest CL	-	-	00h	00h
26	Max. Data Access Time from clock at third highest CL	-	-	00h	00h
27	Minimum row precharge time (=t _{RP})	15ns	18ns	3Ch	48h

Serial Presence Detect Information (cont.)

Byte #	Function described	Function Supported		Hex value	
		D3	C0	D3	C0
28	Minimum row activate to row active delay (=t _{RRD})	10ns	12ns	28h	30h
29	Minimum RAS to CAS delay (=t _{RCD})	15ns	18ns	3Ch	48h
30	Minimum active to precharge time (=t _{RAS})	40ns	42ns	28h	2Ah
31	Module Rank density	256MB		40h	
32	Command and address signal input setup time	0.6ns	.75ns	60h	75h
33	Command and address signal input hold time	0.6ns	.75ns	60h	75h
34	Data signal input setup time	0.4ns	.45ns	40h	45h
35	Data signal input hold time	0.4ns	.45ns	40h	45h
36-40	Superset information (may be used in future)			00h	
41	SDRAM device minimum active to active/auto-refresh time (=t _{RC})	55ns	60ns	37h	3Ch
42	SDRAM device minimum active to autorefresh to active/auto-refresh time (=t _{RFC})	70ns	72ns	46h	48h
43	SDRAM device maximum device cycle time (=t _{CK MAX})	10ns	12ns	28h	30h
44	SDRAM device maximum skew between DQS and DQ signals (=t _{DQSQ})	0.4ns	0.45ns	28h	2Dh
45	SDRAM device maximum read datahold skew factor (=t _{QHS})	0.50ns	0.55ns	50h	55h
46	Superset information (may be used in future)	-		00h	
47	DDR SDRAM DIMM Height	1.125 to 1.25 inches		01h	
48-61	Superset information (may be used in future)	-		00h	
62	SPD data revision code	Initial release 1.0		10h	10h
63	Checksum for Bytes 0 ~ 62	-		87h	31h
64	Manufacturer JEDEC ID code	ProMOS			
65 -71 Manufacturer JEDEC ID code			00h	
72	Manufacturing location	02=Taiwan 04=Malaysia 05=China 0A=S-CH			
73-90	Module part number (ASCII)	V826764B24SB D3: DDR400@CL3-3-3 C0: DDR333@CL2.5-3-3			
91	Manufacturer revision code (For PCB)	0		00	
92	Manufacturer revision code (For component)	0		00	
93	Manufacturing date (Year)	-		-	
94	Manufacturing date (Week)	-		-	
95-98	Assembly serial #	-		-	
99-127	Manufacturer specific data (may be used in future)	Undefined		00h	
128-255	Open for customer use	Undefined		00h	

DC Operating Conditions

(T_A = 0 to 70°C, Voltage referenced to V_{SS} = 0V)

Parameter	Symbol	Min	Typ.	Max	Unit	Note
Power Supply Voltage	V _{DD}	2.3	2.5	2.7	V	
Power Supply Voltage for DDR400	V _{DD}	2.5	2.6	2.7	V	
Power Supply Voltage	V _{DDQ}	2.3	2.5	2.7	V	1
Power Supply Voltage for DDR400	V _{DDQ}	2.5	2.6	2.7	V	1
Input High Voltage	V _{IH}	V _{REF} + 0.15	-	V _{DDQ} + 0.3	V	
Input Low Voltage	V _{IL}	-0.3	-	V _{REF} - 0.15	V	2
I/O Termination Voltage	V _{TT}	V _{REF} - 0.04	V _{REF}	V _{REF} + 0.04	V	
Reference Voltage	V _{REF}	1.15	1.25	1.35	V	
Input Leakage Current	I _I	-2	-	2	μA	
Output Leakage Current	I _{OZ}	-5	-	5	μA	
Output High Current (V _{OUT} = 1.95V)	I _{OH}	-16.8	-	-	mA	
Output Low Current (V _{OUT} = 0.35V)	I _{OL}	16.8	-	-	mA	

- Notes:** 1. V_{DDQ} must not exceed the level of V_{DD}.
 2. V_{IL} (min) is acceptable -1.5V AC pulse width <= 5ns of duration.

AC Operating Conditions

(T_A = 0 to 70 °C, Voltage referenced to V_{SS} = 0V)

Parameter	Symbol	Min	Max	Unit	Note
Input High (Logic 1) Voltage, DQ, DQS and DM signals	V _{IH(AC)}	V _{REF} + 0.31		V	
Input Low (Logic 0) Voltage, DQ, DQS and DM signals	V _{IL(AC)}		V _{REF} - 0.31	V	
Input Differential Voltage, CK and \overline{CK} inputs	V _{ID(AC)}	0.7	V _{DDQ} + 0.6	V	1
Input Crossing Point Voltage, CK and \overline{CK} inputs	V _{IX(AC)}	0.5*V _{DDQ-0.2}	0.5*V _{DDQ+0.2}	V	2

- Notes:** 1. VID is the magnitude of the difference between the input level on CK and the input on \overline{CK} .
 2. The value of VIX is expected to equal 0.5*V_{DDQ} of the transmitting device and must track variations in the DC level of the same.

AC Operating Test Conditions ($T_A = 0$ to 70°C , Voltage referenced to $V_{SS} = 0\text{V}$)

Parameter	Value	Unit
Reference Voltage	$V_{DDQ} \times 0.5$	V
Termination Voltage	$V_{DDQ} \times 0.5$	V
AC Input High Level Voltage (V_{IH} , min)	$V_{REF} + 0.31$	V
AC Input Low Level Voltage (V_{IL} , max)	$V_{REF} - 0.31$	V
Input Timing Measurement Reference Level Voltage	V_{REF}	V
Output Timing Measurement Reference Level Voltage	V_{TT}	V
Input Signal maximum peak swing	1.5	V
Input minimum Signal Slew Rate	1	V/ns
Termination Resistor (R_T)	50	Ohm
Series Resistor (R_S)	25	Ohm
Output Load Capacitance for Access Time Measurement (C_L)	30	pF

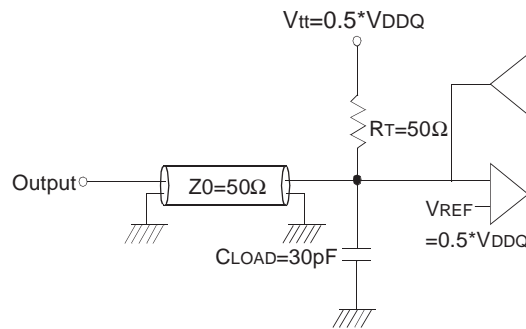

Output Load Circuit (SSTL_2)

Input/Output Capacitance

($V_{DD} = 2.5\text{V}$, $V_{DD} = 2.6\text{V}$ for DDR400, $V_{DDQ} = 2.5\text{V}$, $V_{DDQ} = 2.6\text{V}$ for DDR400, $T_A = 25^\circ\text{C}$, $f = 1\text{MHz}$)

Parameter	Symbol	Min	Max	Unit
Input capacitance ($A_0 \sim A_{11}$, $BA_0 \sim BA_1$, \overline{RAS} , \overline{CAS} , \overline{WE})	C_{IN1}	36	45	pF
Input capacitance (CKE_0)	C_{IN2}	36	45	pF
Input capacitance (\overline{CS}_0)	C_{IN3}	34	42	pF
Input capacitance (CLK_1 , CLK_2)	C_{IN4}	34	38	pF
Data & DQS input/output capacitance ($DQ_0 \sim DQ_{63}$)	C_{OUT}	8	9	pF
Input capacitance ($DM_0 \sim DM_8$)	C_{IN5}	8	9	pF

DDR SDRAM I_{DD} SPEC TABLE

Symbol		D3 PC3200A@CL3	C0 PC2700A@CL2.5	Unit	Notes
IDD0		760	720	mA	
IDD1		920	840	mA	
IDD2P		80	80	mA	
IDD2F		280	280	mA	
IDD2Q		240	240	mA	
IDD3P		360	360	mA	
IDD3N		480	480	mA	
IDD4R		1080	1000	mA	
IDD4W		1160	1080	mA	
IDD5B		1280	1200	mA	
IDD6	Normal	40	40	mA	
	Low power	20	20	mA	
IDD7A		1680	1640	mA	

* Module I_{DD} was calculated on the basis of component I_{DD} and can be differently measured according to DQ loading cap.

Detailed test conditions for DDR SDRAM IDD1 & IDD

IDD1 : Operating current: One bank operation

1. Typical Case : V_{dd} = 2.5V, T=25' C
2. Worst Case : V_{dd} = 2.7V, T= 10' C
3. Only one bank is accessed with t_{RC}(min), Burst Mode, Address and Control inputs on NOP edge are changing once per clock cycle. I_{out} = 0mA
4. Timing patterns
 - DDR333 (166MHz, CL=2.5) : t_{CK}=6ns, CL=2.5, BL=4, t_{RCD}=3*t_{CK}, t_{RC}=10*t_{CK}, t_{RAS}=7*t_{CK}
Read : A0 N N R0 N P0 N N N A0 N - repeat the same timing with random address changing
*50% of data changing at every burst
 - DDR400B (200MHz, CL=3) : t_{CK}=5ns, CL=3, BL=4, t_{RCD}=3*t_{CK}, t_{RC}=12*t_{CK}, t_{RAS}=8*t_{CK}
Read : A0 N N R0 N P0 N N N A0 N - repeat the same timing with random address changing
*50% of data changing at every burst
 - DDR400A (200MHz, CL=2.5) : t_{CK}=5ns, CL=2.5, BL=4, t_{RCD}=3*t_{CK}, t_{RC}=12*t_{CK}, t_{RAS}=8*t_{CK}
Read : A0 N N R0 N P0 N N N A0 N - repeat the same timing with random address changing
*50% of data changing at every burst

Legend : A=Activate, R=Read, W=Write, P=Precharge, N=NOP

AC Characteristics (AC operating conditions unless otherwise noted)

Parameter	Symbol	(DDR400B) D3		(DDR333) C0		Unit	Note	
		Min	Max	Min	Max			
Row Cycle Time	t_{RC}	55	-	60	-	ns		
Auto Refresh Row Cycle Time	t_{RFC}	70	-	72	-	ns		
Row Active Time	t_{RAS}	40	70K	42	70K	ns		
Row Address to Column Address Delay	t_{RCD}	15	-	18	-	ns		
Row Active to Row Active Delay	t_{RRD}	10	-	12	-	ns		
Column Address to Column Address Delay	t_{CCD}	1	-	1	-	CLK		
Row Precharge Time	t_{RP}	15	-	18	-	ns		
Write Recovery Time	t_{WR}	15	-	15	-	ns		
Last Data-In to Read Command	t_{DRL}	1	-	1	-	CLK		
Auto Precharge Write Recovery + Precharge Time	t_{DAL}	35	-	35	-	ns		
System Clock Cycle Time	\overline{CAS} Latency = 3	t_{CK}	5	10	-	-	ns	
	\overline{CAS} Latency = 2.5		6	12	6	12	ns	
Clock High Level Width	t_{CH}	0.45	0.55	0.45	0.55	CLK		
Clock Low Level Width	t_{CL}	0.45	0.55	0.45	0.55	CLK		
Data-Out edge to Clock edge Skew	t_{AC}	-0.70	0.70	-0.70	0.70	ns		
DQS-Out edge to Clock edge Skew	t_{DQSK}	-0.55	0.55	-0.60	0.60	ns		
DQS-Out edge to Data-Out edge Skew	t_{DQSQ}	-	0.40	-	0.45	ns		
Data-Out hold time from DQS	t_{QH}	t_{HPmin} -0.75ns	-	t_{HPmin} -0.75ns	-	ns	1	
Clock Half Period	t_{HP}	$t_{CH/L}$ min	-	$t_{CH/L}$ min	-	ns	1	
Input Setup Time (fast slew rate)	t_{IS}	0.6	-	0.75	-	ns	2,3,5,6	
Input Hold Time (fast slew rate)	t_{IH}	0.6	-	0.75	-	ns	2,3,5,6	
Input Setup Time (slow slew rate)	t_{IS}	0.7	-	0.8	-	ns	2,4,5,6	
Input Hold Time (slow slew rate)	t_{IH}	0.7	-	0.8	-	ns	2,4,5,6	
Input Pulse Width	t_{IPW}	2.2	-	2.2	-	ns	6	
Write DQS High Level Width	t_{DQSH}	0.35		0.35		CLK		
Write DQS Low Level Width	t_{DQSL}	0.35		0.35		CLK		
CLK to First Rising edge of DQS-In	t_{DQSS}	0.72	1.25	0.75	1.25	CLK		
Data-In Setup Time to DQS-In (DQ & DM)	t_{DS}	0.40	-	0.45	-	ns	7	
Data-in Hold Time to DQS-In (DQ & DM)	t_{DH}	0.40	-	0.45	-	ns	7	
DQ & DM Input Pulse Width	t_{DIPW}	1.75	-	1.75	-	ns		
Read DQS Preamble Time	t_{RPRE}	0.9	1.1	0.9	1.1	CLK		

AC Characteristics (cont.)

Parameter	Symbol	(DDR400B) D3		(DDR333) C0		Unit	Note
		Min	Max	Min	Max		
Read DQS Postamble Time	t _{RPST}	0.4	0.6	0.4	0.6	CLK	
Write DQS Preamble Setup Time	t _{WPRES}	0	-	0	-	CLK	
Write DQS Preamble Hold Time	t _{WPREH}	0.25	-	0.25	-	CLK	
Write DQS Postamble Time	t _{WPST}	0.4	0.6	0.4	0.6	CLK	
Mode Register Set Delay	t _{MRD}	2	-	2	-	CLK	
Power Down Exit Time to any command	t _{XPDN}	1	-	1	-	CLK	
Exit Self Refresh to Non-Read Command	t _{XSNR}	75	-	75	-	ns	
Exit Self Refresh to Read Command	t _{XSRD}	200	-	200	-	CLK	8
Average Periodic Refresh Interval	t _{REFI}	-	7.8	-	7.8	us	

- Notes:**
1. This calculation accounts for tDQSQ(max), the pulse width distortion of on-chip circuit and jitter.
 2. Data sampled at the rising edges of the clock : A0~A11, BA0~BA1, CKE, CS, RAS, CAS, WE.
 3. For command/address input slew rate >=1.0V/ns
 4. For command/address input slew rate >=0.5V/ns and <1.0V/ns
 5. CK, CK slew rates are >=1.0V/ns
 6. These parameters guarantee device timing, but they are not necessarily tested on each device, and they may be guaranteed by design or tester correlation.
 7. Data latched at both rising and falling edges of Data Strobes(DQS) : DQ, DM
 8. Minimum of 200 cycles of stable input clocks after Self Refresh Exit command, where CKE is held high, is required to complete Self Refresh Exit and lock the internal DLL circuit of DDR SDRAM.

Absolute Maximum Ratings

Parameter	Symbol	Rating	Unit
Ambient Temperature	T _A	0 ~ 70	°C
Storage Temperature	T _{STG}	-55 ~ 125	°C
Voltage on Any Pin relative to V _{SS}	V _{IN} , V _{OUT}	-0.5 ~ 3.6	V
Voltage on V _{DD} relative to V _{SS}	V _{DD}	-0.5 ~ 3.6	V
Voltage on V _{DDQ} relative to V _{SS}	V _{DDQ}	-0.5 ~ 3.6	V
Output Short Circuit Current	I _{OS}	50	mA
Soldering Temperature • Time	T _{SOLDER}	260 • 10	°C • Sec

Note: Operation at above absolute maximum rating can adversely affect device reliability

Package Dimensions

Units : Inches (Millimeters)

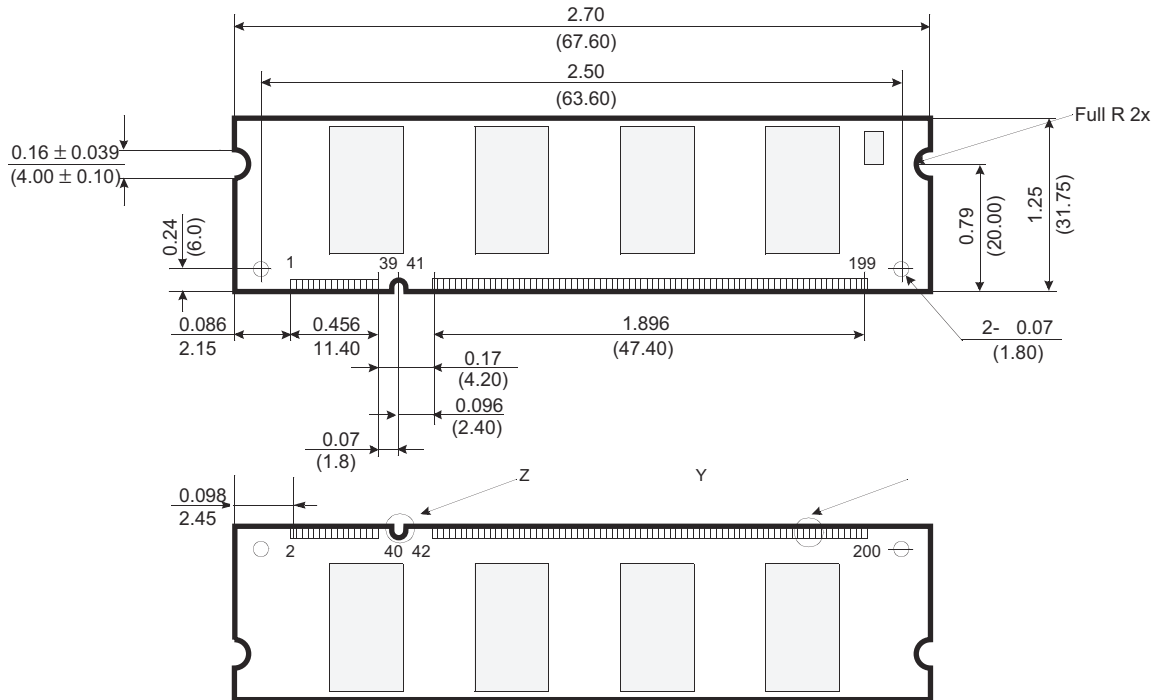

Tolerances : ±.006(.15) unless otherwise specified

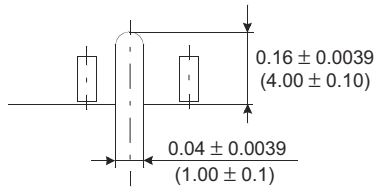
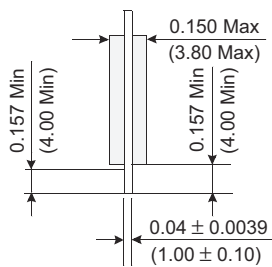

Detail Z

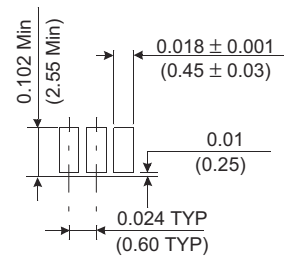

Detail Y

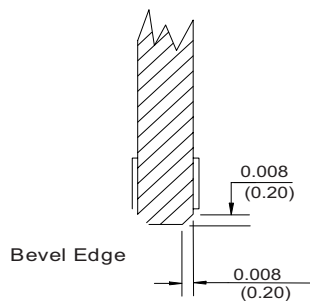

Label Information

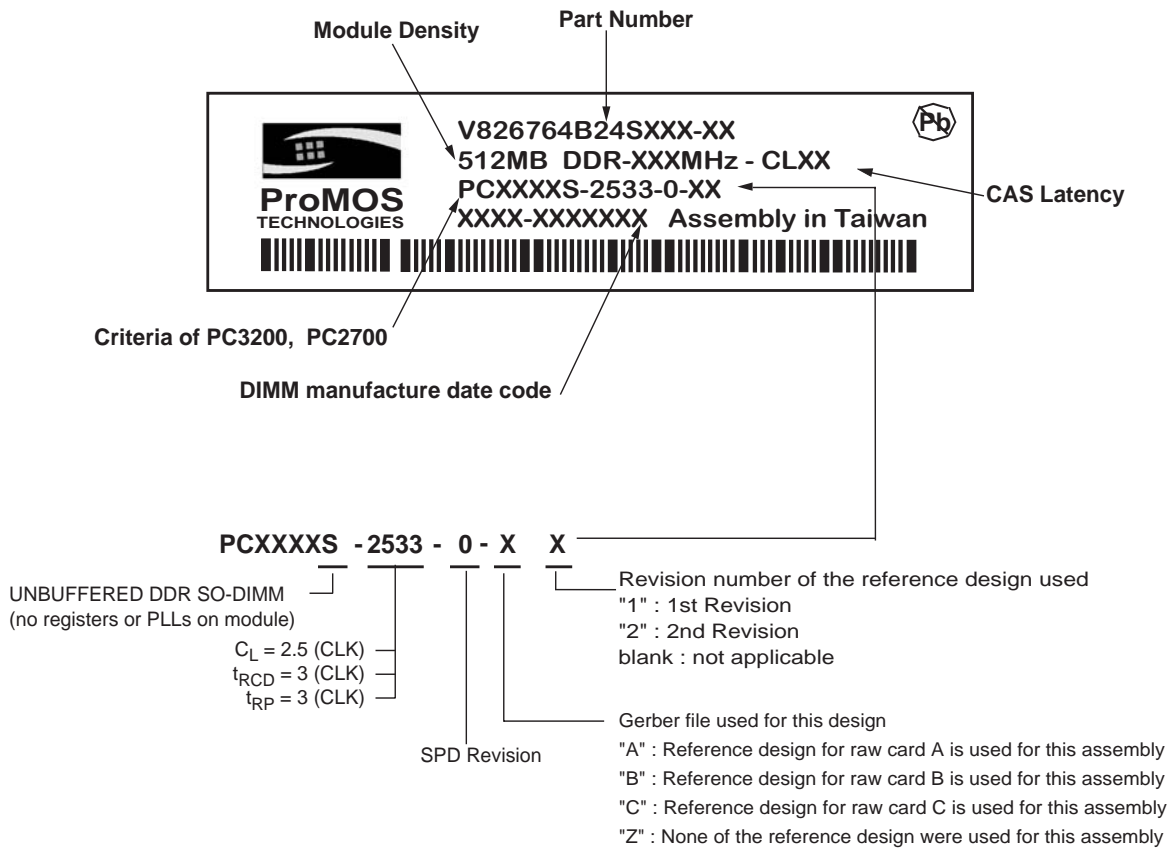

WORLDWIDE OFFICES**SALES OFFICES:****TAIWAN(Hsinchu)**

NO. 19 LI HSIN ROAD
SCIENCE BASED IND. PARK
HSIN CHU, TAIWAN, R.O.C.
PHONE: 886-3-566-3952
FAX: 886-3-578-6028

USA(West)

3910 NORTH FIRST STREET
SAN JOSE, CA 95134
PHONE: 408-433-6000
FAX: 408-433-0952

JAPAN

ONZE 1852 BUILDING 6F
2-14-6 SHINTOMI, CHUO-KU
TOKYO 104-0041
PHONE: 81-3-3537-1400
FAX: 81-3-3537-1402

TAIWAN(Taipei)

7F, NO. 102 MIN-CHUAN E. ROAD
SEC. 3, Taipei, Taiwan, R.O.C
PHONE: 886-2-2545-1213
FAX: 886-2-2545-1209

USA(East)

25 Creekside Road
Hopewell Jct, NY 12533
PHONE:845-223-1689
FAX:845-223-1684

© Copyright ,ProMOS TECHNOLOGY.

Printed in U.S.A.

The information in this document is subject to change without notice.

ProMOS TECH makes no commitment to update or keep current the information contained in this document. No part of this document may be copied or reproduced in any form or by any means without the prior written consent of ProMOS TECH.

ProMOS TECH subjects its products to normal quality control sampling techniques which are intended to provide an assurance of high quality products suitable for usual commercial applications. ProMOS TECH does not do testing appropriate to provide 100% product quality assurance and does not assume any liability for consequential or incidental arising from any use of its products. If such products are to be used in applications in which personal injury might occur from failure, purchaser must do its own quality assurance testing appropriate to such applications.