

**MINI LOGIC SERIES  
2 INPUT NAND GATE**

**S-75V00ANC**

The S-75V00ANC is a single 2-Input NAND Gate fabricated by utilizing advanced silicon-gate CMOS technology which provides the inherent benefit of CMOS low power consumption to achieve ultra high speed operation correspond to LSTTL IC's.

All gates of the internal circuitry have buffered outputs to ensure high noise immunity and output stability.

Input voltage is allowed to be applied even if power voltage is not supplied because no diode is inserted between an input pin and V<sub>CC</sub>.

This allows for interfaces between power supplies of different voltage, output level conversion from 5 V to 3 V and battery backup applications.

■ **Features**

- Wide power supply range: 2 V to 5.5 V
- Low current consumption: 1.0  $\mu$ A max. (at 5.5 V, 25°C)
- Typical propagation delay:  $t_{PD} = 3.7$  ns (at 5 V)
- High noise immunity:  $V_{NIH}=V_{NIL}=28\%$  V<sub>CC</sub> min.
- Power down protection: All pins
- Very small plastic package: SC-88A

■ **Applications**

- Personal computers, peripherals
- Cellular phones
- Cameras
- Games

■ **Pin Assignment**

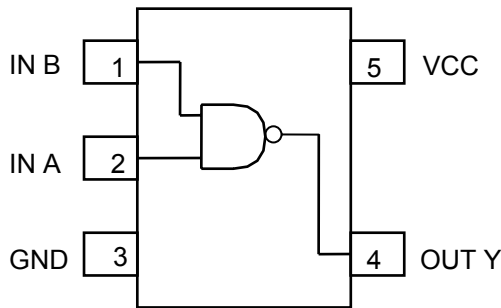

(Top view)

■ **Marking**

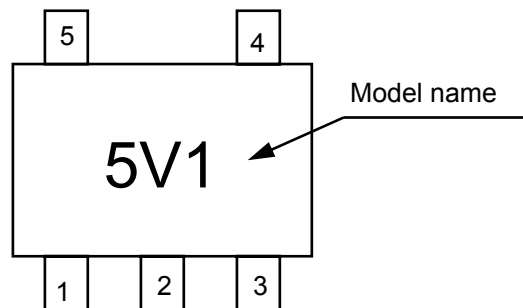

(Top view)

■ **Logic Diagram**

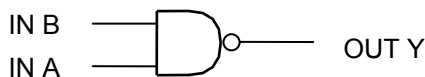

True Values

A	B	Y
L	L	H
L	H	H
H	L	H
H	H	L

■ **Ordering**

Delivery form: Taping only  
 Model name: S-75V00ANC-5V1-TF

■ **Absolute Maximum Ratings**

Ta=25°C

Item	Symbol	Ratings	Unit
Power Supply Voltage	V <sub>CC</sub>	-0.5 to +7.0	V
Input Voltage	V <sub>IN</sub>	-0.5 to +7.0	V
Output Voltage	V <sub>OUT</sub>	-0.5 to V <sub>CC</sub> +0.5	V
Input Parasitic Diode Current	I <sub>IK</sub>	-20	mA
Output Parasitic Diode Current	I <sub>OK</sub>	±20	mA
Output Current	I <sub>OUT</sub>	±25	mA
V <sub>CC</sub> /GND Current	I <sub>CC</sub>	±50	mA
Power Dissipation	P <sub>D</sub>	200	mW
Storage Temp. Range	T <sub>stg</sub>	-65 to +150	°C
Lead Temperature (10 sec.)	TL	260	°C

**Caution** The absolute maximum ratings are rated values exceeding which the product could suffer physical damage. These values must therefore not be exceeded under any conditions.

■ **Recommended Operating Conditions**

Parameter	Symbol	Standard	Unit
Power Voltage	V <sub>CC</sub>	2 to 5.5	V
Input Voltage	V <sub>IN</sub>	0 to 5.5	V
Output Voltage	V <sub>OUT</sub>	0 to V <sub>CC</sub>	V
Op. Temp. Range	T <sub>opr</sub>	-40 to +85	°C
Input Rise and Fall Time	dt/dv	0 to 100 (V <sub>CC</sub> =3.3±0.3 V)	ns/V
		0 to 20 (V <sub>CC</sub> =5±0.5 V)	

■ **DC Characteristics**

Parameter	Symbol	Conditions	Ta=25°C			Ta=-40 to 85°C		Unit		
			V <sub>CC</sub>	MIN.	TYP.	MAX.	MIN.		MAX.	
Input Voltage	"H" level	V <sub>IH</sub>	2.0	1.5	—	—	1.5	—	V	
			3 to 5.5	V <sub>CC</sub> X0.7	—	—	V <sub>CC</sub> X0.7	—		
	"L" level	V <sub>IL</sub>	2.0	—	—	0.5	—	0.5		
			3 to 5.5	—	—	V <sub>CC</sub> X0.3	—	V <sub>CC</sub> X0.3		
Output Voltage	"H" level	V <sub>OH</sub> V <sub>IN</sub> =V <sub>IL</sub> or V <sub>IH</sub>	I <sub>OH</sub> =-50 μA	2.0	1.9	2.0	—	1.9	—	V
				3.0	2.9	3.0	—	2.9	—	
				4.5	4.4	4.5	—	4.4	—	
			I <sub>OH</sub> =-4 mA	3.0	2.58	—	—	2.48	—	
				4.5	3.94	—	—	3.80	—	
				—	—	—	—	—	—	
	"L" level	V <sub>OL</sub> V <sub>IN</sub> =V <sub>IH</sub>	I <sub>OL</sub> =50 μA	2.0	—	0	0.1	—	0.1	
				3.0	—	0	0.1	—	0.1	
				4.5	—	0	0.1	—	0.1	
				I <sub>OL</sub> =4 mA	3.0	—	—	0.36	—	
4.5	—	—	0.36		—	0.44				
Input Current	I <sub>IN</sub>	V <sub>IN</sub> =5.5 V or GND	0 to 5.5	—	—	±0.1	—	±1.0	μA	
Current Consump.	I <sub>CC</sub>	V <sub>IN</sub> =V <sub>CC</sub> or GND	5.5	—	—	1.0	—	10.0	μA	

■ AC Characteristics

Input tr = tf = 3 ns (unless otherwise specified)

Parameter	Symbol	Measurement Conditions		Ta=25°C			Ta=-40 to 85°C		Unit
		V <sub>CC</sub> (V)	C <sub>L</sub> (pF)	MIN.	TYP.	MAX.	MIN.	MAX.	
Output Rise/Fall time	t <sub>PLH</sub> , t <sub>PHL</sub>	3.3±0.3	15	—	5.5	7.9	1.0	9.5	nS
			50	—	10.0	14.0	1.0	15.0	
		5.0±0.5	15	—	3.7	5.5	1.0	6.5	
			50	—	6.1	8.5	1.0	9.0	
Input Capacitance	C <sub>IN</sub>			—	4	10	—	10	pF
Equiv. Int. Capacitance	C <sub>PD</sub>	Note <sup>1</sup>		—	14	—	—	—	pF

Note<sup>1</sup> C<sub>PD</sub> is the no-load equivalent capacitance inside the circuitry. Refer to the measurement circuit shown below.

Current consumption is averaged by the following equation.

$$I_{CC(opr)} = C_{PD} \cdot V_{CC} \cdot f_{in} + I_{CC}$$

Measurement Circuit

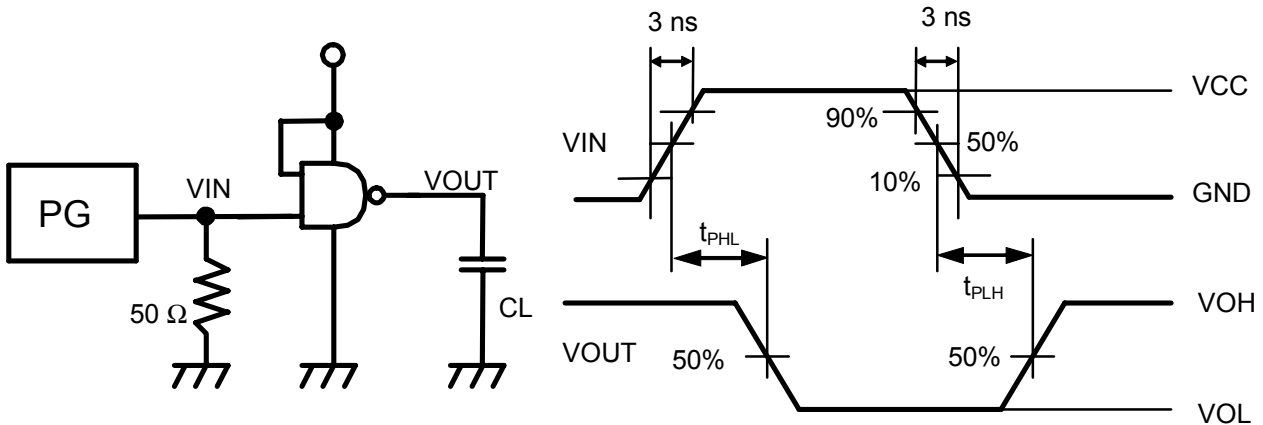

**Remark** No-load output during measurement of current consumption.

■ Input Pin Equivalent Circuit

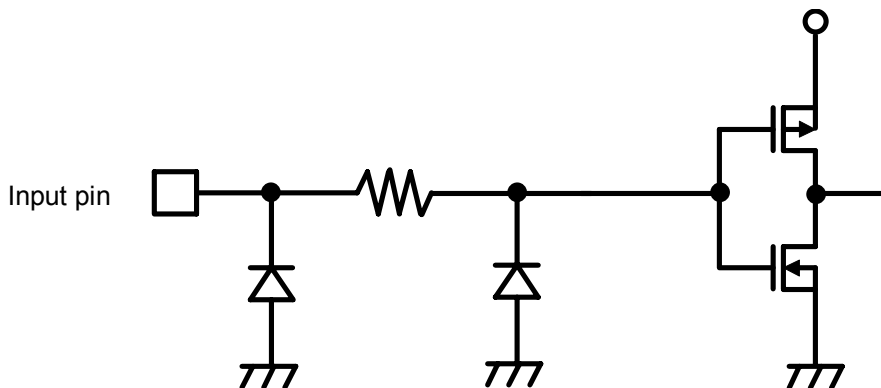

**MINI LOGIC SERIES  
2 INPUT NOR GATE**

**S-75V02ANC**

The S-75V02ANC is a single 2-input NOR gate fabricated by utilizing advanced silicon-gate CMOS technology which provides the inherent benefit of CMOS low power consumption to achieve ultra high speed operation correspond to LSTTL IC's.

All gates of the internal circuitry have buffered outputs to ensure high noise immunity and output stability.

Input voltage is allowed to be applied even if power voltage is not supplied because no diode is inserted between an input pin and V<sub>CC</sub>.

This allows for interfaces between power supplies of different voltage, output level conversion from 5 V to 3 V and battery backup applications.

■ **Features**

- Wide power supply range: 2 V to 5.5 V
- Low current consumption: 1.0  $\mu$ A max. (at 5.5 V, 25°C)
- Typical propagation delay:  $t_{PD} = 3.6$  ns (at 5 V)
- High noise immunity:  $V_{NIH}=V_{NIL}=28\%$  V<sub>CC</sub> min.
- Power down protection: All pins
- Very small plastic package: SC-88A

■ **Applications**

- Personal computers, peripherals
- Cellular phones
- Cameras
- Games

■ **Pin Assignment**

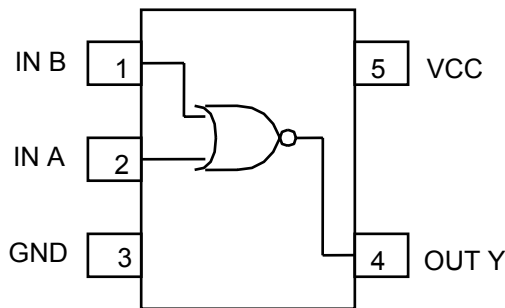

(Top view)

■ **Marking**

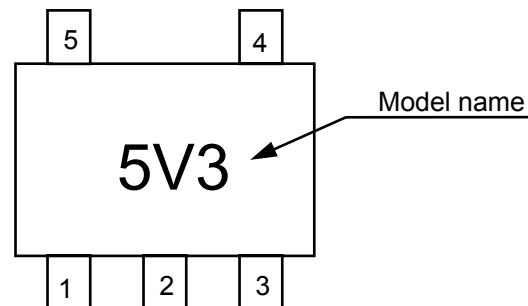

(Top view)

■ **Logic Diagram**

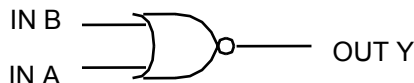

True Values

A	B	Y
L	L	H
L	H	L
H	L	L
H	H	L

## ■ Ordering

Delivery form: Taping only  
Model name: S-75V02ANC-5V3-TF

## ■ Absolute Maximum Ratings

Ta=25°C

Item	Symbol	Ratings	Unit
Power Supply Voltage	V <sub>CC</sub>	-0.5 to +7.0	V
Input Voltage	V <sub>IN</sub>	-0.5 to +7.0	V
Output Voltage	V <sub>OUT</sub>	-0.5 to V <sub>CC</sub> +0.5	V
Input Parasitic Diode Current	I <sub>IK</sub>	-20	mA
Output Parasitic Diode Current	I <sub>OK</sub>	±20	mA
Output Current	I <sub>OUT</sub>	±25	mA
V <sub>CC</sub> /GND Current	I <sub>CC</sub>	±50	mA
Power Dissipation	P <sub>D</sub>	200	mW
Storage Temp. Range	T <sub>stg</sub>	-65 to +150	°C
Lead Temperature (10 sec.)	TL	260	°C

**Caution** The absolute maximum ratings are rated values exceeding which the product could suffer physical damage. These values must therefore not be exceeded under any conditions.

## ■ Recommended Operating Conditions

Parameter	Symbol	Standard	Unit
Power Voltage	V <sub>CC</sub>	2 to 5.5	V
Input Voltage	V <sub>IN</sub>	0 to 5.5	V
Output Voltage	V <sub>OUT</sub>	0 to V <sub>CC</sub>	V
Op. Temp. Range	T <sub>opr</sub>	-40 to +85	°C
Input Rise and Fall Time	dt/dv	0 to 100 (V <sub>CC</sub> =3.3±0.3 V)	ns/V
		0 to 20 (V <sub>CC</sub> =5±0.5 V)	

## ■ DC Characteristics

Parameter	Symbol	Conditions	Ta=25°C			Ta=-40 to 85°C		Unit			
			V <sub>CC</sub>	MIN.	TYP.	MAX.	MIN.		MAX.		
Input Voltage	"H" level	V <sub>IH</sub>	2.0	1.5	—	—	1.5	—	V		
			3 to 5.5	V <sub>CC</sub> X0.7	—	—	V <sub>CC</sub> X0.7	—			
	"L" level	V <sub>IL</sub>	2.0	—	—	0.5	—	0.5			
			3 to 5.5	—	—	V <sub>CC</sub> X0.3	—	V <sub>CC</sub> X0.3			
Output Voltage	"H" level	V <sub>OH</sub>	V <sub>IN</sub> =V <sub>IL</sub>	I <sub>OH</sub> =-50 μA	2.0	1.9	2.0	—	1.9	—	V
					3.0	2.9	3.0	—	2.9	—	
					4.5	4.4	4.5	—	4.4	—	
				I <sub>OH</sub> =-4 mA	3.0	2.58	—	—	2.48	—	
					4.5	3.94	—	—	3.80	—	
					—	—	—	—	—	—	
	"L" level	V <sub>OL</sub>	V <sub>IN</sub> =V <sub>IH</sub> or V <sub>IL</sub>	I <sub>OL</sub> =50 μA	2.0	—	0	0.1	—	0.1	
					3.0	—	0	0.1	—	0.1	
				I <sub>OL</sub> =4 mA	3.0	—	—	0.36	—	0.44	
					4.5	—	—	0.36	—	0.44	
Input Current	I <sub>IN</sub>	V <sub>IN</sub> =5.5 V or GND	0 to 5.5	—	—	±0.1	—	±1.0	μA		
Current Consump.	I <sub>CC</sub>	V <sub>IN</sub> =V <sub>CC</sub> or GND	5.5	—	—	1.0	—	10.0	μA		

■ **AC Characteristics**

Input  $t_r = t_f = 3 \text{ ns}$  (unless otherwise specified)

Parameter	Symbol	Measurement Conditions		Ta=25°C			Ta=-40 to 85°C		Unit
				V <sub>CC</sub> (V)	C <sub>L</sub> (pF)	MIN.	TYP.	MAX.	
Output Rise/Fall time	$t_{PLH}, t_{PHL}$	3.3±0.3	15	—	5.6	7.9	1.0	9.5	ns
			50	—	10.0	14.0	1.0	15.0	
		5.0±0.5	15	—	3.6	5.5	1.0	6.5	
			50	—	5.7	8.0	1.0	9.0	
Input Capacitance	C <sub>IN</sub>			—	4	10	—	10	pF
Equiv. Int. Capacitance	C <sub>PD</sub>	Note <sup>1</sup>		—	15	—	—	—	pF

Note<sup>1</sup> C<sub>PD</sub> is the no-load equivalent capacitance inside the circuitry. Refer to the measurement circuit shown below.

Current consumption is averaged by the following equation.

$$I_{CC(opr)} = C_{PD} \cdot V_{CC} \cdot f_{in} + I_{CC}$$

Measurement Circuit

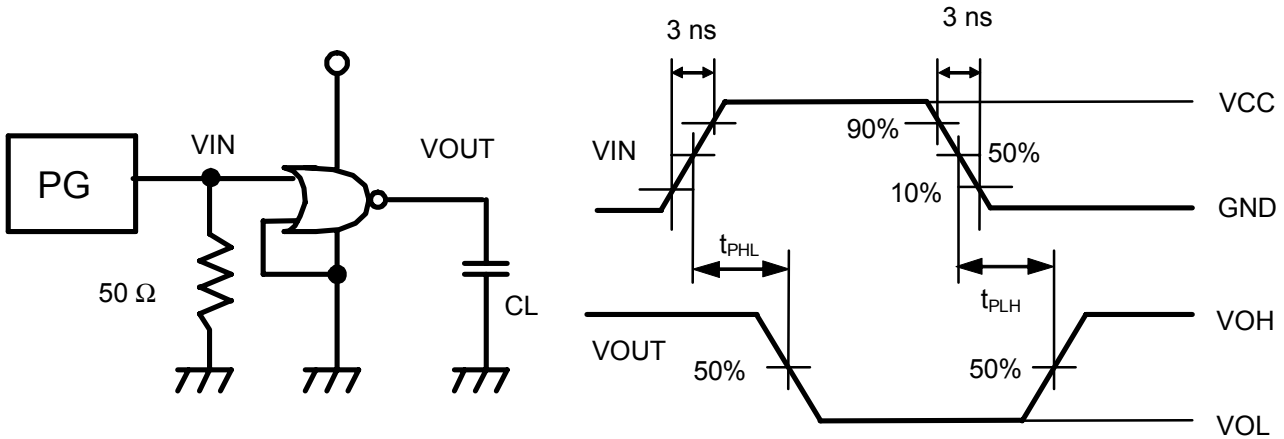

**Remark** No-load output during measurement of current consumption.

■ **Input Pin Equivalent Circuit**

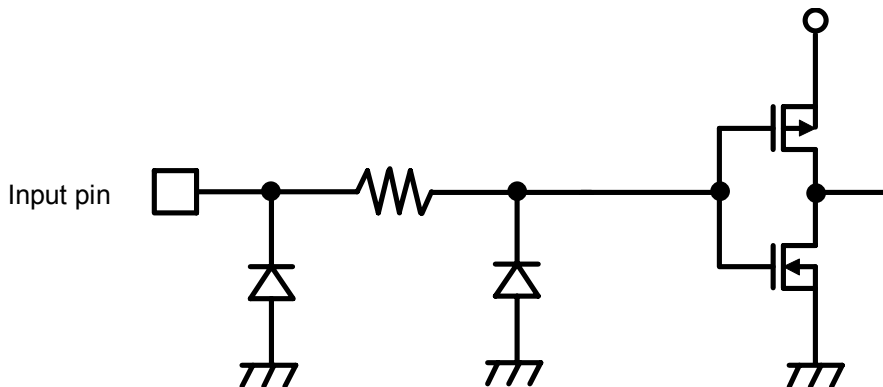

**MINI LOGIC SERIES  
INVERTER**

**S-75V04ANC**

The S-75V04ANC is a INVERTER fabricated by utilizing advanced silicon-gate CMOS technology which provides the inherent benefit of CMOS low power consumption to achieve ultra high speed operation correspond to LSTTL IC's.

The special purpose unbuffered circuit design is suitable for a wide variety of linear circuits.

Input voltage is allowed to be applied even if power voltage is not supplied because no diode is inserted between an input pin and  $V_{CC}$ .

This allows for interfaces between power supplies of different voltage, output level conversion from 5 V to 3 V and battery backup applications.

■ **Features**

- Wide power supply range: 2 V to 5.5 V
- Low current consumption: 1.0  $\mu$ A max. (at 5.5 V, 25°C)
- Typical propagation delay:  $t_{PD} = 3.8$  ns (at 5 V)
- High noise immunity:  $V_{NIH}=V_{NIL}=28\% V_{CC}$  min.
- Power down protection: All pins
- Very small plastic package: SC-88A

■ **Applications**

- Personal computers, peripherals
- Cellular phones
- Cameras
- Games

■ **Pin Assignment**

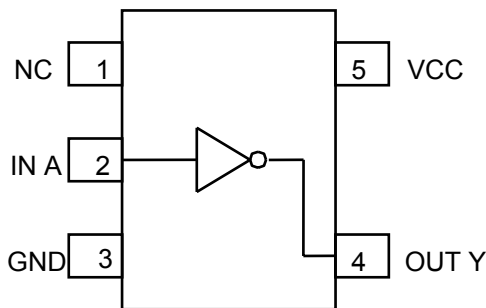

(Top view)

■ **Marking**

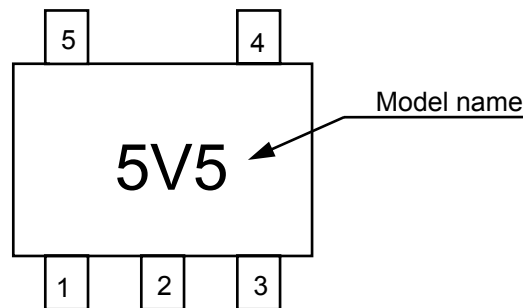

(Top view)

■ **Logic Diagram**

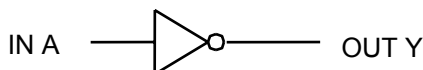

True Values

A	Y
L	H
H	L

■ **Ordering**

Delivery form: Taping only  
 Model name: S-75V04ANC-5V5-TF

■ **Absolute Maximum Ratings**

Ta=25°C

Item	Symbol	Ratings	Unit
Power Supply Voltage	V <sub>CC</sub>	-0.5 to +7.0	V
Input Voltage	V <sub>IN</sub>	-0.5 to +7.0	V
Output Voltage	V <sub>OUT</sub>	-0.5 to V <sub>CC</sub> +0.5	V
Input Parasitic Diode Current	I <sub>IK</sub>	-20	mA
Output Parasitic Diode Current	I <sub>OK</sub>	±20	mA
Output Current	I <sub>OUT</sub>	±25	mA
V <sub>CC</sub> /GND Current	I <sub>CC</sub>	±50	mA
Power Dissipation	P <sub>D</sub>	200	mW
Storage Temp. Range	T <sub>stg</sub>	-65 to +150	°C
Lead Temperature (10 sec.)	TL	260	°C

**Caution** The absolute maximum ratings are rated values exceeding which the product could suffer physical damage. These values must therefore not be exceeded under any conditions.

■ **Recommended Operating Conditions**

Parameter	Symbol	Standard	Unit
Power Voltage	V <sub>CC</sub>	2 to 5.5	V
Input Voltage	V <sub>IN</sub>	0 to 5.5	V
Output Voltage	V <sub>OUT</sub>	0 to V <sub>CC</sub>	V
Op. Temp. Range	T <sub>opr</sub>	-40 to +85	°C
Input Rise and Fall Time	dt/dv	0 to 100 (V <sub>CC</sub> =3.3±0.3 V)	ns/V
		0 to 20 (V <sub>CC</sub> =5±0.5 V)	

■ **DC Characteristics**

Parameter	Symbol	Conditions	Ta=25°C			Ta=-40 to 85°C		Unit			
			V <sub>CC</sub>	MIN.	TYP.	MAX.	MIN.		MAX.		
Input Voltage	"H" level	V <sub>IH</sub>	2.0	1.5	—	—	1.5	V			
			3 to 5.5	V <sub>CC</sub> X0.7	—	—	V <sub>CC</sub> X0.7		—		
	"L" level	V <sub>IL</sub>	2.0	—	—	0.5	—		0.5		
			3 to 5.5	—	—	V <sub>CC</sub> X0.3	—		V <sub>CC</sub> X0.3		
Output Voltage	"H" level	V <sub>OH</sub>	V <sub>IN</sub> =V <sub>IL</sub>	I <sub>OH</sub> =50 μA	2.0	1.9	2.0	—	1.9	—	V
					3.0	2.9	3.0	—	2.9	—	
					4.5	4.4	4.5	—	4.4	—	
				I <sub>OH</sub> =4 mA	3.0	2.58	—	—	2.48	—	
					4.5	3.94	—	—	3.80	—	
					4.5	3.94	—	—	3.80	—	
	"L" level	V <sub>OL</sub>	V <sub>IN</sub> =V <sub>IH</sub>	I <sub>OL</sub> =50 μA	2.0	—	0	0.1	—	0.1	
					3.0	—	0	0.1	—	0.1	
				I <sub>OL</sub> =4 mA	3.0	—	—	0.36	—	0.44	
					4.5	—	—	0.36	—	0.44	
Input Current	I <sub>IN</sub>	V <sub>IN</sub> =5.5 V or GND	0 to 5.5	—	—	±0.1	—	±1.0	μA		
Current Consump.	I <sub>CC</sub>	V <sub>IN</sub> =V <sub>CC</sub> or GND	5.5	—	—	1.0	—	10.0	μA		

■ AC Characteristics

Input tr = tf = 3 ns (unless otherwise specified)

Parameter	Symbol	Measurement Conditions		Ta=25°C			Ta=-40 to 85°C		Unit
		V <sub>CC</sub> (V)	C <sub>L</sub> (pF)	MIN.	TYP.	MAX.	MIN.	MAX.	
Output Rise/Fall time	t <sub>PLH</sub> , t <sub>PHL</sub>	3.3±0.3	15	—	5.0	7.1	1.0	8.5	ns
			50	—	9.6	13.5	1.0	14.5	
		5.0±0.5	15	—	3.8	5.5	1.0	6.5	
			50	—	5.7	8.0	1.0	9.0	
Input Capacitance	C <sub>IN</sub>			—	4	10	—	10	pF
Equiv. Int. Capacitance	C <sub>PD</sub>	Note <sup>1</sup>		—	13	—	—	—	pF

Note<sup>1</sup> C<sub>PD</sub> is the no-load equivalent capacitance inside the circuitry. Refer to the measurement circuit shown below.

Current consumption is averaged by the following equation.

$$I_{CC(opr)} = C_{PD} \cdot V_{CC} \cdot f_{in} + I_{CC}$$

Measurement Circuit

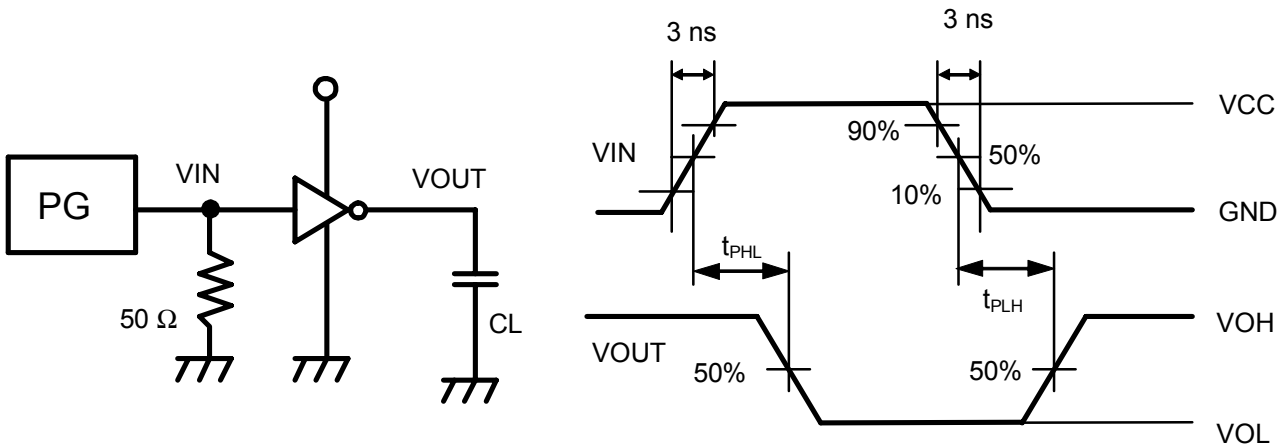

**Remark** No-load output during measurement of current consumption.

■ Input pin Equivalent Circuit

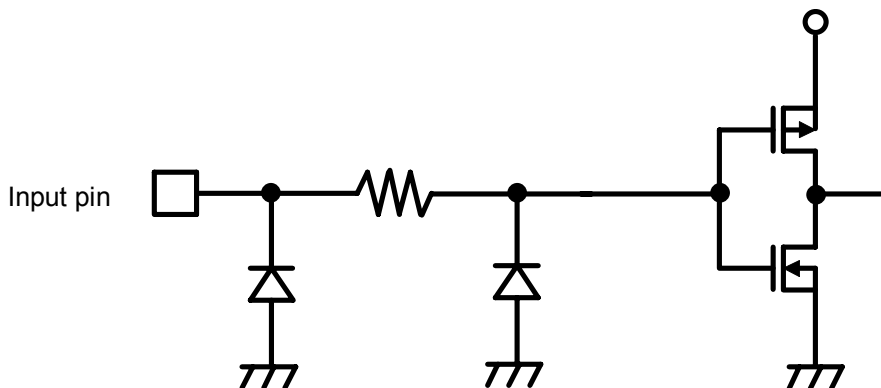

**MINI LOGIC SERIES  
INVERTER (unbuffer)**

**S-75VU04ANC**

The S-75VU04ANC is a inverter fabricated by utilizing advanced silicon-gate CMOS technology which provides the inherent benefit of CMOS low power consumption to achieve ultra high speed operation correspond to LSTTL IC's.

The special purpose unbuffered circuit design is suitable for a wide variety of linear circuits.

Input voltage is allowed to be applied even if power voltage is not supplied because no diode is inserted between an input pin and  $V_{CC}$ .

This allows for interfaces between power supplies of different voltage, output level conversion from 5 V to 3 V and battery backup applications.

■ **Features**

- Wide power supply range: 2 V to 5.5 V
- Low current consumption: 1.0  $\mu$ A max. (at 5.5 V, 25°C)
- Typical propagation delay:  $t_{PD} = 3.5$  ns (at 5 V)
- High noise immunity:  $V_{NIH}=V_{NIL}=10\% V_{CC}$  min.
- Power down protection: All pins
- Very small plastic package: SC-88A

■ **Applications**

- Personal computers, peripherals
- Cellular phones
- Cameras
- Games

■ **Pin Assignment**

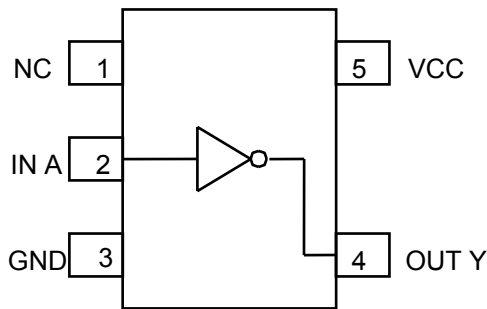

(Top view)

■ **Marking**

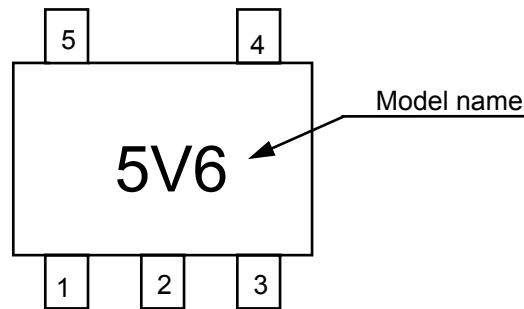

(Top view)

■ **Logic Diagram**

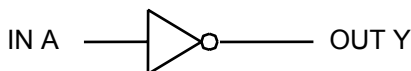

True Values

A	Y
L	H
H	L

## ■ Ordering

Delivery form: Taping only  
Model name: S-75VU04ANC-5V6-TF

## ■ Absolute Maximum Ratings

Ta=25°C

Item	Symbol	Ratings	Unit
Power Supply Voltage	V <sub>CC</sub>	-0.5 to +7.0	V
Input Voltage	V <sub>IN</sub>	-0.5 to +7.0	V
Output Voltage	V <sub>OUT</sub>	-0.5 to V <sub>CC</sub> +0.5	V
Input Parasitic Diode Current	I <sub>IK</sub>	-20	mA
Output Parasitic Diode Current	I <sub>OK</sub>	±20	mA
Output Current	I <sub>OUT</sub>	±25	mA
V <sub>CC</sub> /GND Current	I <sub>CC</sub>	±50	mA
Power Dissipation	P <sub>D</sub>	200	mW
Storage Temp. Range	T <sub>stg</sub>	-65 to +150	°C
Lead Temperature (10 sec.)	TL	260	°C

**Caution** The absolute maximum ratings are rated values exceeding which the product could suffer physical damage. These values must therefore not be exceeded under any conditions.

## ■ Recommended Operating Conditions

Parameter	Symbol	Standard	Unit
Power Voltage	V <sub>CC</sub>	2 to 5.5	V
Input Voltage	V <sub>IN</sub>	0 to 5.5	V
Output Voltage	V <sub>OUT</sub>	0 to V <sub>CC</sub>	V
Op. Temp. Range	Topr	-40 to +85	°C

## ■ DC Characteristics

Parameter	Symbol	Conditions	Ta=25°C			Ta=-40 to 85°C		Unit			
			V <sub>CC</sub>	MIN.	TYP.	MAX.	MIN.		MAX.		
Input Voltage	"H" level	V <sub>IH</sub>	V <sub>OUT</sub> =V <sub>OL</sub>	2.0	1.7	—	—	1.7	—	V	
				3 to 5.5	V <sub>CC</sub> X0.8	—	—	V <sub>CC</sub> X0.8	—		
	"L" level	V <sub>IL</sub>	V <sub>OUT</sub> =V <sub>OH</sub>	2.0	—	—	0.3	—	0.3		
				3 to 5.5	—	—	V <sub>CC</sub> X0.2	—	V <sub>CC</sub> X0.2		
Output Voltage	"H" level	V <sub>OH</sub>	V <sub>IN</sub> =V <sub>IL</sub>	I <sub>OH</sub> =-50 μA	2.0	1.8	2.0	—	1.8	—	V
					3.0	2.7	3.0	—	2.7	—	
					4.5	4.0	4.5	—	4.0	—	
		V <sub>IN</sub> = GND	I <sub>OH</sub> =-4 mA	3.0	2.58	—	—	2.48	—		
				I <sub>OH</sub> =-8 mA	4.5	3.94	—	—	3.80	—	
					—	—	—	—	—	—	
	"L" level	V <sub>OL</sub>	V <sub>IN</sub> =V <sub>IH</sub>	I <sub>OL</sub> =50 μA	2.0	—	0	0.2	—	0.2	
					3.0	—	0	0.3	—	0.3	
					4.5	—	0	0.5	—	0.5	
			V <sub>IN</sub> = V <sub>CC</sub>	I <sub>OL</sub> =4 mA	3.0	—	—	0.36	—	0.44	
I <sub>OL</sub> =8 mA	4.5	—			—	0.36	—	0.44			
	Input Current	I <sub>IN</sub>	V <sub>IN</sub> =5.5 V or GND	0 to 5.5	—	—	±0.1	—	±1.0	μA	
Current Consump.	I <sub>CC</sub>	V <sub>IN</sub> =V <sub>CC</sub> or GND	5.5	—	—	1.0	—	10.0	μA		

■ **AC Characteristics**

Input  $t_r = t_f = 3 \text{ ns}$  (unless otherwise specified)

Parameter	Symbol	Measurement Conditions		Ta=25°C			Ta=-40 to 85°C		Unit
		V <sub>CC</sub> (V)	C <sub>L</sub> (pF)	MIN.	TYP.	MAX.	MIN.	MAX.	
Output Rise/Fall time	t <sub>PLH</sub> , t <sub>PHL</sub>	3.3±0.3	15	—	5.0	8.9	1.0	10.5	ns
			50	—	8.9	12.5	1.0	13.5	
		5.0±0.5	15	—	3.5	5.5	1.0	6.5	
			50	—	5.4	7.5	1.0	8.0	
Input Capacitance	C <sub>IN</sub>			—	5	10	—	10	pF
Equiv. Int. Capacitance	C <sub>PD</sub>	Note <sup>1</sup>		—	6	—	—	—	pF

Note<sup>1</sup> C<sub>PD</sub> is the no-load equivalent capacitance inside the circuitry. Refer to the measurement circuit shown below.

Current consumption is averaged by the following equation.

$$I_{CC(opr)} = C_{PD} \cdot V_{CC} \cdot f_{in} + I_{CC}$$

Measurement Circuit

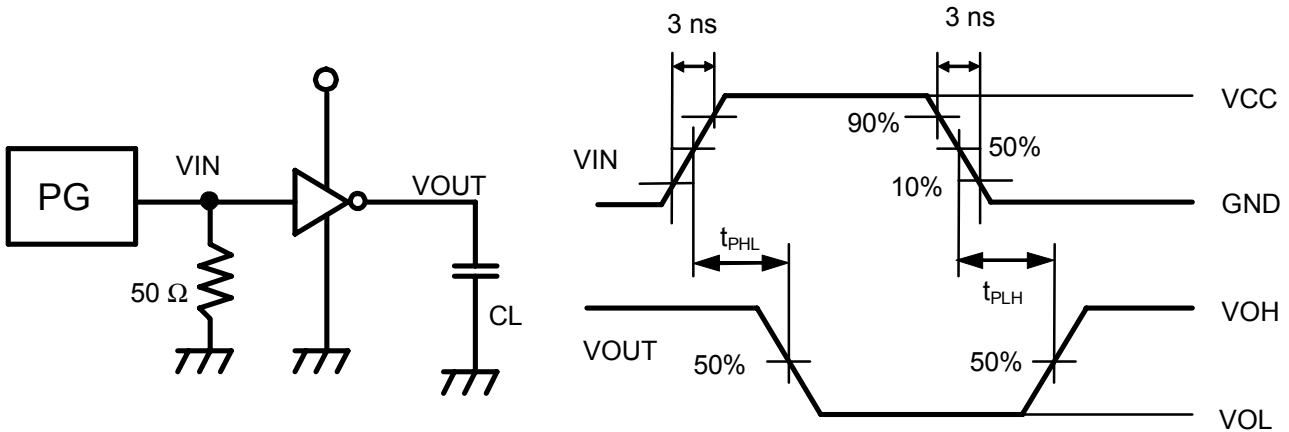

**Remark** No-load output during measurement of current consumption.

■ **Input Pin Equivalent Circuit**

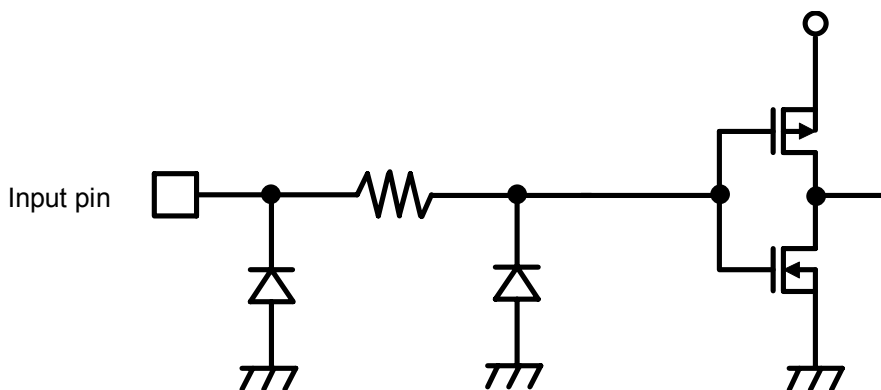

**MINI LOGIC SERIES  
2 INPUT AND GATE**

**S-75V08ANC**

The S-75V08ANC is a Single 2-Input AND Gate fabricated by utilizing advanced silicon-gate CMOS technology which provides the inherent benefit of CMOS low power consumption to achieve ultra high speed operation correspond to LSTTL IC's.

All gates of the internal circuitry have buffered outputs to ensure high noise immunity and output stability.

Input voltage is allowed to be applied even if power voltage is not supplied because no diode is inserted between an input pin and  $V_{CC}$ .

This allows for interfaces between power supplies of different voltage, output level conversion from 5 V to 3 V and battery backup applications.

■ **Features**

- Wide power supply range: 2 V to 5.5 V
- Low current consumption: 1.0  $\mu$ A max. (at 5.5 V, 25°C)
- Typical propagation delay:  $t_{PD} = 4.3$  ns (at 5 V)
- High noise immunity:  $V_{NIH}=V_{NIL}=28\%$   $V_{CC}$  min.
- Power down protection: All pins
- Very small plastic package: SC-88A

■ **Applications**

- Personal computers, peripherals
- Cellular phones
- Cameras
- Games

■ **Pin Assignment**

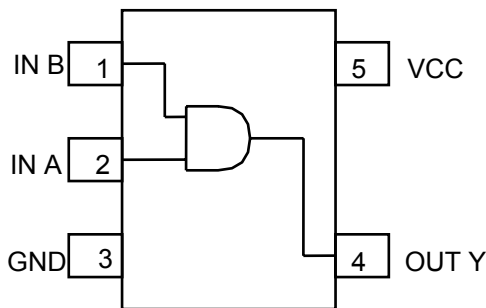

(Top view)

■ **Marking**

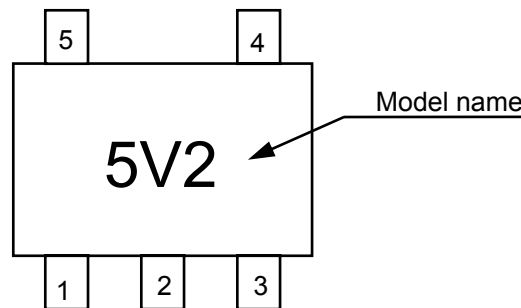

(Top view)

■ **Logic Diagram**

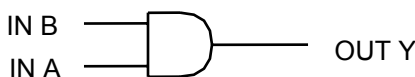

True Values

A	B	Y
L	L	L
L	H	L
H	L	L
H	H	H

■ **Ordering**

Delivery form: Taping only  
 Model name: S-75V08ANC-5V2-TF

■ **Absolute Maximum Ratings**

Ta=25°C

Item	Symbol	Ratings	Unit
Power Supply Voltage	V <sub>CC</sub>	-0.5 to +7.0	V
Input Voltage	V <sub>IN</sub>	-0.5 to +7.0	V
Output Voltage	V <sub>OUT</sub>	-0.5 to V <sub>CC</sub> +0.5	V
Input Parasitic Diode Current	I <sub>IK</sub>	-20	mA
Output Parasitic Diode Current	I <sub>OK</sub>	±20	mA
Output Current	I <sub>OUT</sub>	±25	mA
V <sub>CC</sub> /GND Current	I <sub>CC</sub>	±50	mA
Power Dissipation	P <sub>D</sub>	200	mW
Storage Temp. Range	T <sub>stg</sub>	-65 to +150	°C
Lead Temperature (10 sec.)	TL	260	°C

**Caution** The absolute maximum ratings are rated values exceeding which the product could suffer physical damage. These values must therefore not be exceeded under any conditions.

■ **Recommended Operating Conditions**

Parameter	Symbol	Standard	Unit
Power Voltage	V <sub>CC</sub>	2 to 5.5	V
Input Voltage	V <sub>IN</sub>	0 to 5.5	V
Output Voltage	V <sub>OUT</sub>	0 to V <sub>CC</sub>	V
Op. Temp. Range	T <sub>opr</sub>	-40 to +85	°C
Input Rise and Fall Time	dt/dv	0 to 100 (V <sub>CC</sub> =3.3±0.3 V)	ns/V
		0 to 20 (V <sub>CC</sub> =5±0.5 V)	

■ **DC Characteristics**

Parameter	Symbol	Conditions	Ta=25°C			Ta=-40 to 85°C		Unit			
			V <sub>CC</sub>	MIN.	TYP.	MAX.	MIN.		MAX.		
Input Voltage	"H" level	V <sub>IH</sub>	2.0	1.5	—	—	1.5	—	V		
			3 to 5.5	V <sub>CC</sub> X0.7	—	—	V <sub>CC</sub> X0.7	—			
	"L" level	V <sub>IL</sub>	2.0	—	—	0.5	—	0.5			
			3 to 5.5	—	—	V <sub>CC</sub> X0.3	—	V <sub>CC</sub> X0.3			
Output Voltage	"H" level	V <sub>OH</sub>	V <sub>IN</sub> =V <sub>IH</sub>	I <sub>OH</sub> =-50 μA	2.0	1.9	2.0	—	1.9	—	V
					3.0	2.9	3.0	—	2.9	—	
					4.5	4.4	4.5	—	4.4	—	
				I <sub>OH</sub> =-4 mA	3.0	2.58	—	—	2.48	—	
					4.5	3.94	—	—	3.80	—	
					—	—	—	—	—	—	
	"L" level	V <sub>OL</sub>	V <sub>IN</sub> =V <sub>IH</sub> or V <sub>IL</sub>	I <sub>OL</sub> =50 μA	2.0	—	0	0.1	—	0.1	
					3.0	—	0	0.1	—	0.1	
				I <sub>OL</sub> =4 mA	4.5	—	0	0.1	—	0.1	
					—	—	—	—	—	—	
I <sub>OL</sub> =8 mA	3.0	—	—	0.36	—	0.44					
	4.5	—	—	0.36	—	0.44					
Input Current	I <sub>IN</sub>	V <sub>IN</sub> =5.5 V or GND	0 to 5.5	—	—	±0.1	—	±1.0	μA		
Current Consump.	I <sub>CC</sub>	V <sub>IN</sub> =V <sub>CC</sub> or GND	5.5	—	—	1.0	—	10.0	μA		

■ AC Characteristics

Input  $t_r = t_f = 3 \text{ ns}$  (unless otherwise specified)

Parameter	Symbol	Measurement Conditions		Ta=25°C			Ta=-40 to 85°C		Unit
		V <sub>CC</sub> (V)	C <sub>L</sub> (pF)	MIN.	TYP.	MAX.	MIN.	MAX.	
Output Rise/Fall time	t <sub>PLH</sub> , t <sub>PHL</sub>	3.3±0.3	15	—	6.2	8.8	1.0	10.5	ns
			50	—	9.6	13.5	1.0	14.5	
		5.0±0.5	15	—	4.3	5.9	1.0	7.0	
			50	—	5.7	7.9	1.0	9.0	
Input Capacitance	C <sub>IN</sub>			—	4	10	—	10	pF
Equiv. Int. Capacitance	C <sub>PD</sub>	Note <sup>1</sup>		—	14	—	—	—	pF

Note<sup>1</sup> C<sub>PD</sub> is the no-load equivalent capacitance inside the circuitry. Refer to the measurement circuit shown below.

Current consumption is averaged by the following equation.

$$I_{CC(opr)} = C_{PD} \cdot V_{CC} \cdot f_{in} + I_{CC}$$

Measurement Circuit

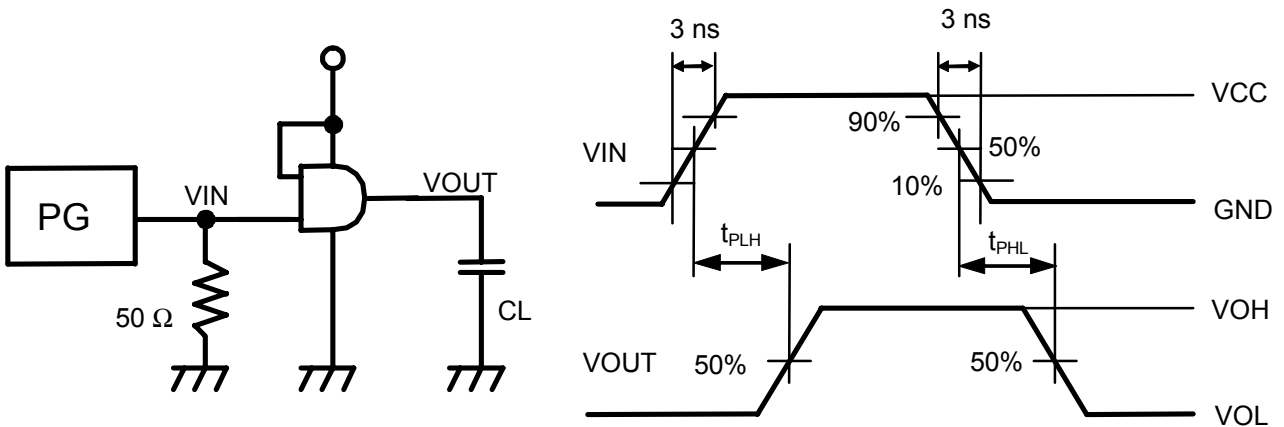

**Remark** No-load output during measurement of current consumption.

■ Input Pin Equivalent Circuit

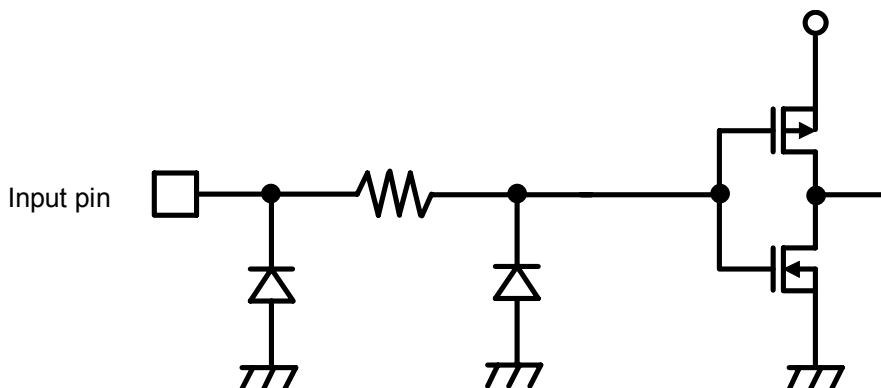

**MINI LOGIC SERIES  
SCHMITT INVERTER**

**S-75V14ANC**

The S-75V14ANC is a SCHMITT INVERTER fabricated by utilizing advanced silicon-gate CMOS technology which provides the inherent benefit of CMOS low power consumption to achieve ultra high speed operation correspond to LSTTL IC's.

All gates of the internal circuitry have buffered outputs to ensure high noise immunity and output stability.

Input voltage is allowed to be applied even if power voltage is not supplied because no diode is inserted between an input pin and V<sub>CC</sub>.

This allows for interfaces between power supplies of different voltage, output level conversion from 5 V to 3 V and battery backup applications.

■ **Features**

- Wide power supply range: 2 V to 5.5 V
- Low current consumption: 1.0  $\mu$ A max. (at 5.5 V, 25°C)
- Typical propagation delay:  $t_{PD} = 5.5$  ns (at 5 V)
- High noise immunity:  $V_{NIH}=V_{NIL}=28\%$  V<sub>CC</sub> min.
- Power down protection: All pins
- Very small plastic package: SC-88A

■ **Applications**

- Personal computers, peripherals
- Cellular phones
- Cameras
- Games

■ **Pin Assignment**

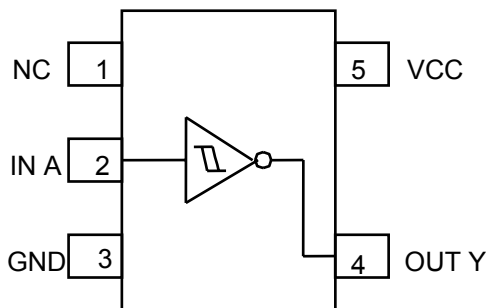

(Top view)

■ **Marking**

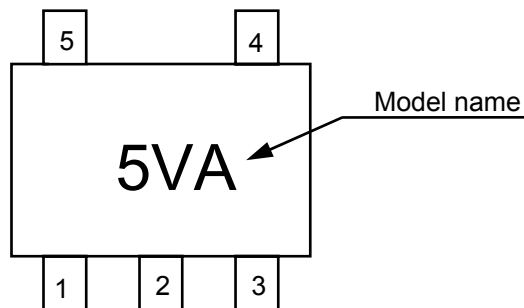

(Top view)

■ **Logic Diagram**

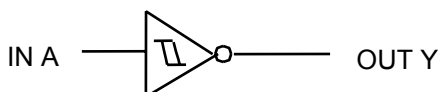

True Values

A	B
L	H
H	L

## ■ Ordering

Delivery form: Taping only  
 Model name: S-75V14ANC-5VA-TF

## ■ Absolute Maximum Ratings

Ta=25°C

Item	Symbol	Ratings	Unit
Power Supply Voltage	V <sub>CC</sub>	-0.5 to +7.0	V
Input Voltage	V <sub>IN</sub>	-0.5 to +7.0	V
Output Voltage	V <sub>OUT</sub>	-0.5 to V <sub>CC</sub> +0.5	V
Input Parasitic Diode Current	I <sub>IK</sub>	-20	mA
Output Parasitic Diode Current	I <sub>OK</sub>	±20	mA
Output Current	I <sub>OUT</sub>	±25	mA
V <sub>CC</sub> /GND Current	I <sub>CC</sub>	±50	mA
Power Dissipation	P <sub>D</sub>	200	mW
Storage Temp. Range	T <sub>stg</sub>	-65 to +150	°C
Lead Temperature (10 sec.)	TL	260	°C

**Caution** The absolute maximum ratings are rated values exceeding which the product could suffer physical damage. These values must therefore not be exceeded under any conditions.

## ■ Recommended Operating Conditions

Parameter	Symbol	Standard	Unit
Power Voltage	V <sub>CC</sub>	2 to 5.5	V
Input Voltage	V <sub>IN</sub>	0 to 5.5	V
Output Voltage	V <sub>OUT</sub>	0 to V <sub>CC</sub>	V
Op. Temp. Range	Topr	-40 to +85	°C

## ■ DC Characteristics

Parameter	Symbol	Conditions	Ta=25°C			Ta=-40 to 85°C		Unit			
			V <sub>CC</sub>	MIN.	TYP.	MAX.	MIN.		MAX.		
Threshold Voltage	"H" level	V <sub>P</sub>	3.0	—	—	2.20	—	2.20	V		
			4.5	—	—	3.15	—	3.15			
			5.5	—	—	3.85	—	3.85			
	"L" level		3.0	0.90	—	—	0.90	—			
			4.5	1.35	—	—	1.35	—			
			5.5	1.65	—	—	1.65	—			
Hysteresis	V <sub>H</sub>	3.0	0.30	—	1.20	0.30	1.20	V			
		4.5	0.40	—	1.40	0.40	1.40				
		5.5	0.5	—	1.60	0.5	1.60				
Output Voltage	"H" level	V <sub>OH</sub>	V <sub>IN</sub> =V <sub>IL</sub>	I <sub>OH</sub> =50 μA	2.0	1.9	2.0	—	1.9	—	V
					3.0	2.9	3.0	—	2.9	—	
				4.5	4.4	4.5	—	4.4	—		
				I <sub>OH</sub> =4 mA	3.0	2.58	—	—	2.48	—	
					4.5	3.94	—	—	3.80	—	
				"L" level	V <sub>OL</sub>	V <sub>IN</sub> =V <sub>IH</sub>	I <sub>OL</sub> =50 μA	2.0	—	0	
	3.0	—	0					0.1	—	0.1	
	4.5	—	0				0.1	—	0.1		
	I <sub>OL</sub> =4 mA	3.0	—				—	0.36	—	0.44	
		4.5	—				—	0.36	—	0.44	
	Input Current	I <sub>IN</sub>	V <sub>IN</sub> =5.5 V or GND				0 to 5.5	—	—	±0.1	
				5.5	—	—	1.0	—	10.0	μA	
Current Consump.		I <sub>CC</sub>	V <sub>IN</sub> =V <sub>CC</sub> or GND	5.5	—	—	1.0	—	10.0	μA	

■ **AC Characteristics**

Input  $t_r = t_f = 3 \text{ ns}$  (unless otherwise specified)

Parameter	Symbol	Measurement Conditions		Ta=25°C			Ta=-40 to 85°C		Unit
		V <sub>CC</sub> (V)	C <sub>L</sub> (pF)	MIN.	TYP.	MAX.	MIN.	MAX.	
Output Rise/Fall Time	t <sub>PLH</sub> , t <sub>PHL</sub>	3.3±0.3	15	—	8.3	12.8	1.0	15.0	ns
			50	—	10.8	16.3	1.0	18.5	
		5.0±0.5	15	—	5.5	8.6	1.0	10.0	
			50	—	7.0	10.6	1.0	12.0	
Input Capacitance	C <sub>IN</sub>			—	4	10	—	10	pF
Equiv. Int. Capacitance	C <sub>PD</sub>	Note <sup>1</sup>		—	14	—	—	—	pF

Note<sup>1</sup> C<sub>PD</sub> is the no-load equivalent capacitance inside the circuitry. Refer to the measurement circuit shown below.

Current consumption is averaged by the following equation.

$$I_{CC(opr)} = C_{PD} \cdot V_{CC} \cdot f_{in} + I_{CC}$$

Measurement Circuit

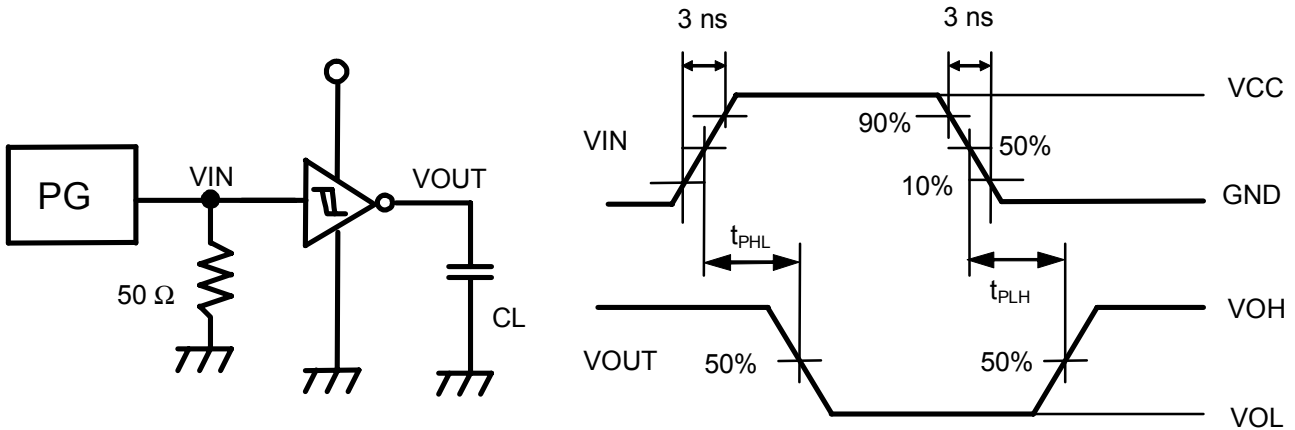

**Remark** No-load output during measurement of current consumption.

■ **Input Pin Equivalent Circuit**

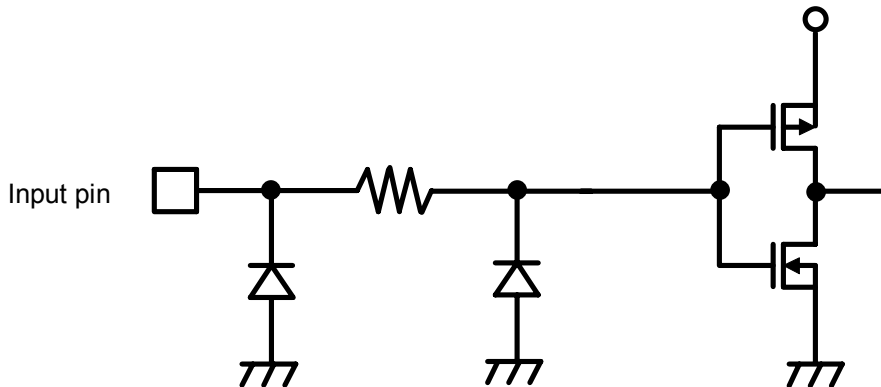

**MINI LOGIC SERIES  
2 INPUT OR GATE**

**S-75V32ANC**

The S-75V32ANC is a single 2-input OR gate fabricated by utilizing advanced silicon-gate CMOS technology which provides the inherent benefit of CMOS low power consumption to achieve ultra high speed operation correspond to LSTTL IC's.

All gates of the internal circuitry have buffered outputs to ensure high noise immunity and output stability.

Input voltage is allowed to be applied even if power voltage is not supplied because no diode is inserted between an input pin and  $V_{CC}$ .

This allows for interfaces between power supplies of different voltage, output level conversion from 5 V to 3 V and battery backup applications.

■ **Features**

- Wide power supply range: 2 V to 5.5 V
- Low current consumption: 1.0  $\mu$ A max. (at 5.5 V, 25°C)
- Typical propagation delay:  $t_{PD} = 3.8$  ns (at 5 V)
- High noise immunity:  $V_{NIH}=V_{NIL}=28\%$   $V_{CC}$  min.
- Power down protection: All pins
- Very small plastic package: SC-88A

■ **Applications**

- Personal computers, peripherals
- Cellular phones
- Cameras
- Games

■ **Pin Assignment**

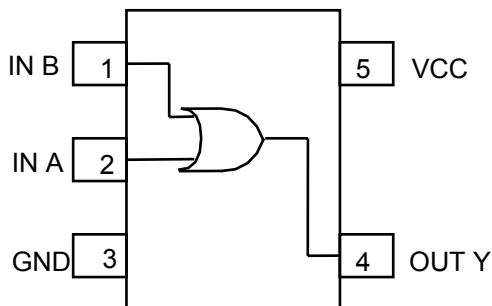

(Top view)

■ **Marking**

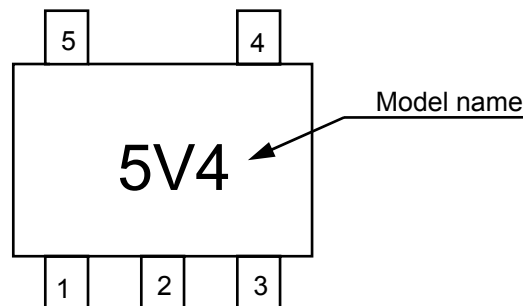

(Top view)

■ **Logic Diagram**

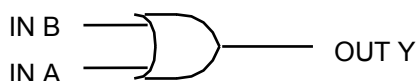

True Values

A	B	Y
L	L	L
L	H	H
H	L	H
H	H	H

■ **Ordering**

Delivery form: Taping only  
 Model name: S-75V32ANC-5V4-TF

■ **Absolute Maximum Ratings**

Ta=25°C

Item	Symbol	Ratings	Unit
Power Supply Voltage	V <sub>CC</sub>	-0.5 to +7.0	V
Input Voltage	V <sub>IN</sub>	-0.5 to +7.0	V
Output Voltage	V <sub>OUT</sub>	-0.5 to V <sub>CC</sub> +0.5	V
Input Parasitic Diode Current	I <sub>IK</sub>	-20	mA
Output Parasitic Diode Current	I <sub>OK</sub>	±20	mA
Output Current	I <sub>OUT</sub>	±25	mA
V <sub>CC</sub> /GND Current	I <sub>CC</sub>	±50	mA
Power Dissipation	P <sub>D</sub>	200	mW
Storage Temp. Range	T <sub>stg</sub>	-65 to +150	°C
Lead Temperature (10 sec.)	TL	260	°C

**Caution** The absolute maximum ratings are rated values exceeding which the product could suffer physical damage. These values must therefore not be exceeded under any conditions.

■ **Recommended Operating Conditions**

Parameter	Symbol	Standard	Unit
Power Voltage	V <sub>CC</sub>	2 to 5.5	V
Input Voltage	V <sub>IN</sub>	0 to 5.5	V
Output Voltage	V <sub>OUT</sub>	0 to V <sub>CC</sub>	V
Op. Temp. Range	T <sub>opr</sub>	-40 to +85	°C
Input Rise and Fall Time	dt/dv	0 to 100 (V <sub>CC</sub> =3.3±0.3 V)	ns/V
		0 to 20 (V <sub>CC</sub> =5±0.5 V)	

■ **DC Characteristics**

Parameter	Symbol	Conditions	Ta=25°C			Ta=-40 to 85°C		Unit		
			V <sub>CC</sub>	MIN.	TYP.	MAX.	MIN.		MAX.	
Input Voltage	"H" level	V <sub>IH</sub>	2.0	1.5	—	—	1.5	V		
			3 to 5.5	V <sub>CC</sub> X0.7	—	—	V <sub>CC</sub> X0.7		—	
	"L" level	V <sub>IL</sub>	2.0	—	—	0.5	—		0.5	
			3 to 5.5	—	—	V <sub>CC</sub> X0.3	—		V <sub>CC</sub> X0.3	
Output Voltage	"H" level	V <sub>OH</sub> V <sub>IN</sub> =V <sub>IL</sub> or V <sub>IH</sub>	I <sub>OH</sub> =-50 μA	2.0	1.9	2.0	—	1.9	V	
				3.0	2.9	3.0	—	2.9		—
				4.5	4.4	4.5	—	4.4		—
			I <sub>OH</sub> =-4 mA	3.0	2.58	—	—	2.48		—
				4.5	3.94	—	—	3.80		—
					—	—	—	—		—
	"L" level	V <sub>OL</sub> V <sub>IN</sub> =V <sub>IL</sub>	I <sub>OL</sub> =50 μA	2.0	—	0	0.1	—		0.1
				3.0	—	0	0.1	—		0.1
			I <sub>OL</sub> =4 mA	3.0	—	—	0.36	—		0.44
				4.5	—	—	0.36	—		0.44
Input Current	I <sub>IN</sub>	V <sub>IN</sub> =5.5 V or GND	0 to 5.5	—	—	±0.1	—	±1.0	μA	
Current Consump.	I <sub>CC</sub>	V <sub>IN</sub> =V <sub>CC</sub> or GND	5.5	—	—	1.0	—	10.0	μA	

■ AC Characteristics

Input  $t_r = t_f = 3 \text{ ns}$  (unless otherwise specified)

Parameter	Symbol	Measurement Conditions		Ta=25°C			Ta=-40 to 85°C		Unit
		V <sub>CC</sub> (V)	C <sub>L</sub> (pF)	MIN.	TYP.	MAX.	MIN.	MAX.	
Output Rise/Fall time	t <sub>PLH</sub> , t <sub>PHL</sub>	3.3±0.3	15	—	5.5	7.9	1.0	9.5	ns
			50	—	10.0	14.0	1.0	15.0	
		5.0±0.5	15	—	3.8	5.5	1.0	6.5	
			50	—	6.1	8.5	1.0	9.0	
Input Capacitance	C <sub>IN</sub>			—	4	10	—	10	pF
Equiv. Int. Capacitance	C <sub>PD</sub>	Note <sup>1</sup>		—	15	—	—	—	pF

Note<sup>1</sup> C<sub>PD</sub> is the no-load equivalent capacitance inside the circuitry. Refer to the measurement circuit shown below.

Current consumption is averaged by the following equation.

$$I_{CC(opr)} = C_{PD} \cdot V_{CC} \cdot f_{in} + I_{CC}$$

Measurement Circuit

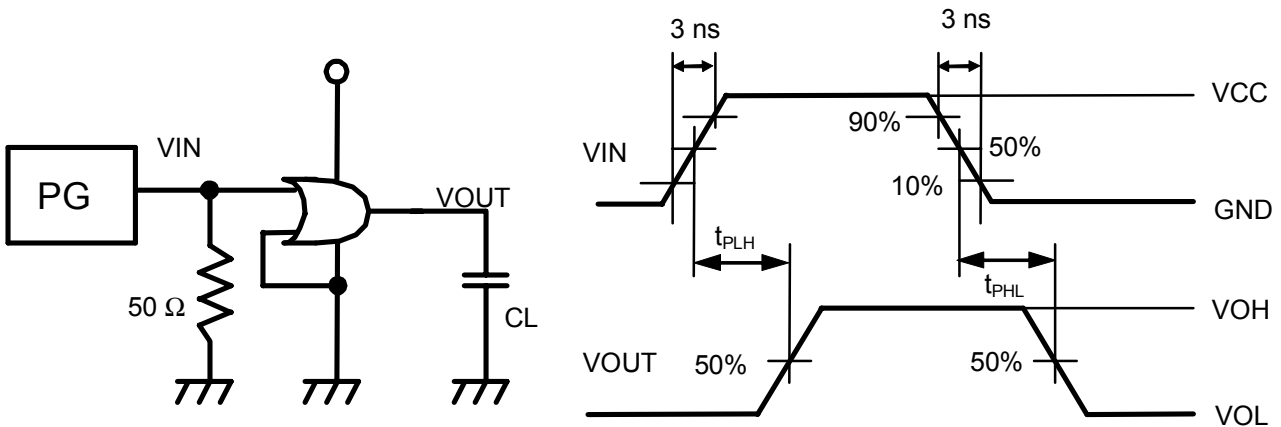

**Remark** No-load output during measurement of current consumption.

■ Input Pin Equivalent Circuit

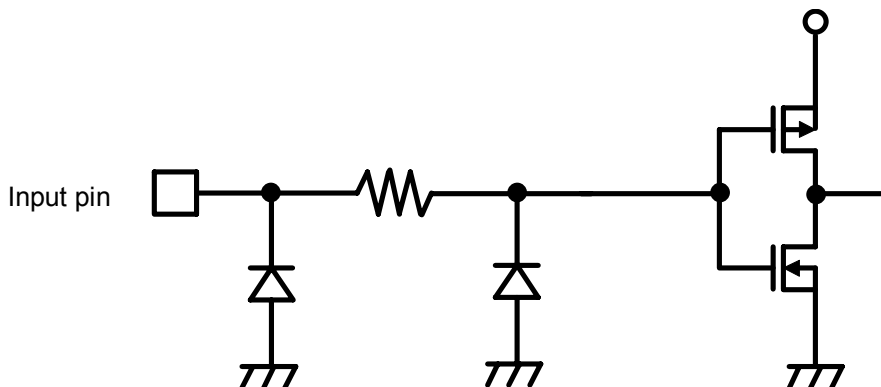

**MINI LOGIC SERIES  
EXCLUSIVE OR GATE**

**S-75V86ANC**

The S-75V86ANC is a EXCLUSIVE OR GATE fabricated by utilizing advanced silicon-gate CMOS technology which provides the inherent benefit of CMOS low power consumption to achieve ultra high speed operation correspond to LSTTL IC's.

All gates of the internal circuitry have buffered outputs to ensure high noise immunity and output stability.

Input voltage is allowed to be applied even if power voltage is not supplied because no diode is inserted between an input pin and V<sub>CC</sub>.

This allows for interfaces between power supplies of different voltage, output level conversion from 5 V to 3 V and battery backup applications.

■ **Features**

- Wide power supply range: 2 V to 5.5 V
- Low current consumption: 1.0  $\mu$ A max. (at 5.5 V, 25°C)
- Typical propagation delay:  $t_{PD} = 4.8$  ns (at 5 V)
- High noise immunity:  $V_{NIH}=V_{NIL}=28\%$  V<sub>CC</sub> min.
- Power down protection: All pins
- Very small plastic package: SC-88A

■ **Applications**

- Personal computers, peripherals
- Cellular phones
- Cameras
- Games

■ **Pin Assignment**

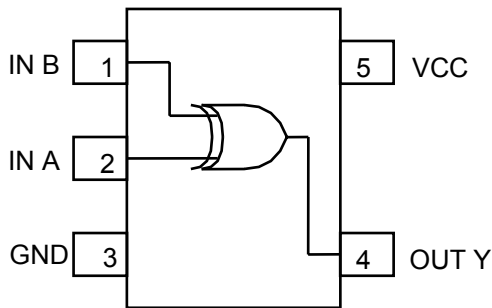

(Top view)

■ **Marking**

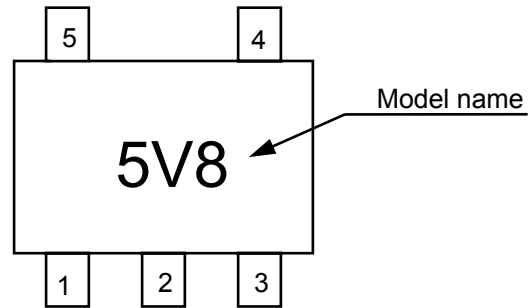

(Top view)

■ **Logic Diagram**

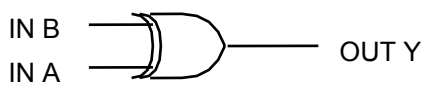

True Values

A	B	Y
L	L	L
L	H	H
H	L	H
H	H	L

## ■ Ordering

Delivery form: Taping only  
Model name: S-75V86ANC-5V8-TF

## ■ Absolute Maximum Ratings

Ta=25°C

Item	Symbol	Ratings	Unit
Power Supply Voltage	V <sub>CC</sub>	-0.5 to +7.0	V
Input Voltage	V <sub>IN</sub>	-0.5 to +7.0	V
Output Voltage	V <sub>OUT</sub>	-0.5 to V <sub>CC</sub> +0.5	V
Input Parasitic Diode Current	I <sub>IK</sub>	-20	mA
Output Parasitic Diode Current	I <sub>OK</sub>	±20	mA
Output Current	I <sub>OUT</sub>	±25	mA
V <sub>CC</sub> /GND Current	I <sub>CC</sub>	±50	mA
Power Dissipation	P <sub>D</sub>	200	mW
Storage Temp. Range	T <sub>stg</sub>	-65 to +150	°C
Lead Temperature (10 sec.)	TL	260	°C

**Caution** The absolute maximum ratings are rated values exceeding which the product could suffer physical damage. These values must therefore not be exceeded under any conditions.

## ■ Recommended Operating Conditions

Parameter	Symbol	Standard	Unit
Power Voltage	V <sub>CC</sub>	2 to 5.5	V
Input Voltage	V <sub>IN</sub>	0 to 5.5	V
Output Voltage	V <sub>OUT</sub>	0 to V <sub>CC</sub>	V
Op. Temp. Range	Topr	-40 to +85	°C
Input Rise and Fall Time	dt/dv	0 to 100 (V <sub>CC</sub> =3.3±0.3 V)	ns/V
		0 to 20 (V <sub>CC</sub> =5±0.5 V)	

## ■ DC Characteristics

Parameter	Symbol	Conditions	Ta=25°C			Ta=-40 to 85°C		Unit		
			V <sub>CC</sub>	MIN.	TYP.	MAX.	MIN.		MAX.	
Input Voltage	"H" level	V <sub>IH</sub>	2.0	1.5	—	—	1.5	—	V	
			3 to 5.5	V <sub>CC</sub> X0.7	—	—	V <sub>CC</sub> X0.7	—		
	"L" level	V <sub>IL</sub>	2.0	—	—	0.5	—	0.5		
			3 to 5.5	—	—	V <sub>CC</sub> X0.3	—	V <sub>CC</sub> X0.3		
Output Voltage	"H" level	V <sub>OH</sub> V <sub>IN</sub> =V <sub>IL</sub> or V <sub>IH</sub>	I <sub>OH</sub> =-50 μA	2.0	1.9	2.0	—	1.9	—	V
				3.0	2.9	3.0	—	2.9	—	
				4.5	4.4	4.5	—	4.4	—	
			I <sub>OH</sub> =-4 mA	3.0	2.58	—	—	2.48	—	
				4.5	3.94	—	—	3.80	—	
				4.5	3.94	—	—	3.80	—	
	"L" level	V <sub>OL</sub> V <sub>IN</sub> =V <sub>IL</sub> or V <sub>IH</sub>	I <sub>OL</sub> =50 μA	2.0	—	0	0.1	—	0.1	
				3.0	—	0	0.1	—	0.1	
			I <sub>OL</sub> =4 mA	4.5	—	0	0.1	—	0.1	
				3.0	—	—	0.36	—	0.44	
4.5	—	—	0.36	—	0.44					
Input Current	I <sub>IN</sub>	V <sub>IN</sub> =5.5 V or GND	0 to 5.5	—	—	±0.1	—	±1.0	μA	
Current Consump.	I <sub>CC</sub>	V <sub>IN</sub> =V <sub>CC</sub> or GND	5.5	—	—	1.0	—	10.0	μA	

■ **AC Characteristics**

Input  $t_r = t_f = 3 \text{ ns}$  (unless otherwise specified)

Parameter	Symbol	Measurement Conditions		Ta=25°C			Ta=-40 to 85°C		Unit
				V <sub>CC</sub> (V)	C <sub>L</sub> (pF)	MIN.	TYP.	MAX.	
Output Rise/Fall Time	$t_{PLH}$ , $t_{PHL}$	3.3±0.3	15	—	7.0	11.0	1.0	13.0	ns
			50	—	10.4	14.5	1.0	16.5	
		5.0±0.5	15	—	4.8	6.8	1.0	8.0	
			50	—	6.5	9.0	1.0	10.0	
Input Capacitance	C <sub>IN</sub>			—	4	10	—	10	pF
Equiv. Int. Capacitance	C <sub>PD</sub>	Note <sup>1</sup>		—	18	—	—	—	pF

Note<sup>1</sup> C<sub>PD</sub> is the no-load equivalent capacitance inside the circuitry. Refer to the measurement circuit shown below.

Current consumption is averaged by the following equation.

$$I_{CC(opr)} = C_{PD} \cdot V_{CC} \cdot f_{in} + I_{CC}$$

Measurement Circuit

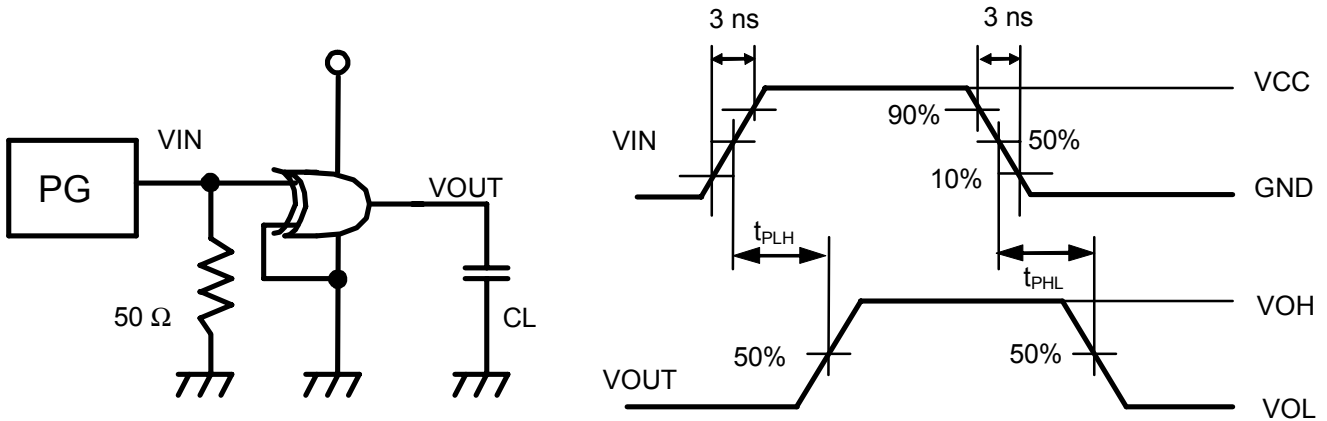

**Remark** No-load output during measurement of current consumption.

■ **Input Pin Equivalent Circuit**

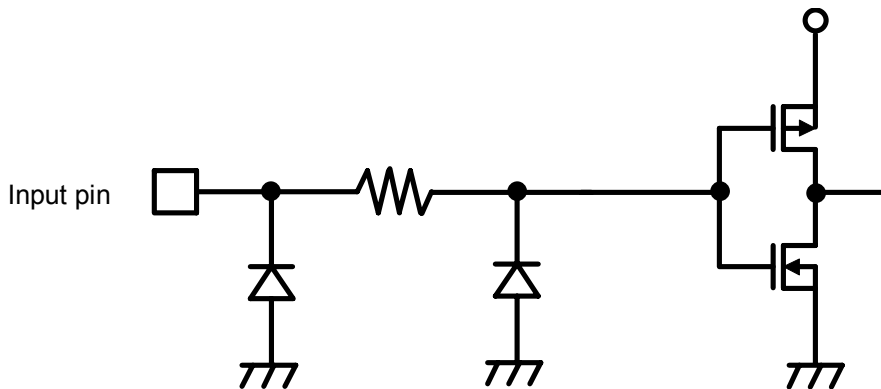

**MINI LOGIC SERIES  
2 INPUT NAND GATE**

**S-75L00ANC**

The S-75L00ANC is a single 2-input NAND gate fabricated by utilizing advanced silicon-gate CMOS technology which provides the inherent benefit of CMOS low power consumption to achieve operation by only a couple of batteries (1 to 3 V).

The internal circuitry has buffered outputs to ensure high noise immunity and output stability.

Input voltage is allowed to be applied even if power voltage is not supplied because no diode is inserted between an input pin and  $V_{CC}$ .

This allows for interfaces between power supplies of different voltage, output level conversion from 3 V to 1 V and battery backup applications.

■ **Features**

- Wide power supply range: 1 V to 3.6 V
- Low current consumption: 1.0  $\mu$ A max. (at 3.6 V, 25°C)
- Typical propagation delay:  $t_{PD} = 7$  ns (at 3 V)
- High noise immunity:  $V_{NIH} = V_{NIL} = 28\% V_{CC}$  min.
- Power down protection: All pins
- Very small plastic package: SC-88A

■ **Applications**

- Personal computers, peripherals
- Cellular phones
- Cameras
- Games

■ **Pin Assignment**

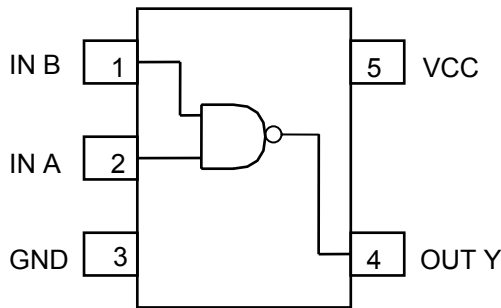

(Top view)

■ **Marking**

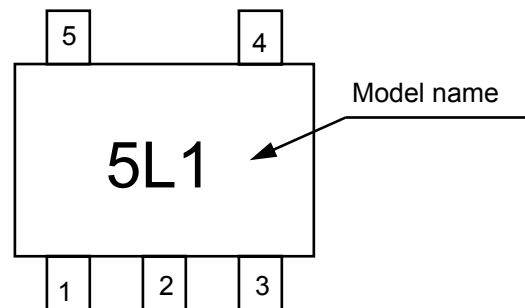

(Top view)

■ **Logic Diagram**

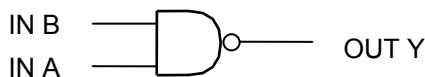

True Values

A	B	Y
L	L	H
L	H	H
H	L	H
H	H	L

■ **Ordering**

Delivery form: Taping only  
 Model name: S-75L00ANC-5L1-TF

■ **Absolute Maximum Ratings**

Ta=25°C

Item	Symbol	Ratings	Unit
Power Supply Voltage	V <sub>CC</sub>	-0.5 to +5.0	V
Input Voltage	V <sub>IN</sub>	-0.5 to +5.0	V
Output Voltage	V <sub>OUT</sub>	-0.5 to V <sub>CC</sub> +0.5	V
Input Parasitic Diode Current	I <sub>IK</sub>	-20	mA
Output Parasitic Diode Current	I <sub>OK</sub>	±20	mA
Output Current	I <sub>OUT</sub>	±12.5	mA
V <sub>CC</sub> /GND Current	I <sub>CC</sub>	±25	mA
Power Dissipation	P <sub>D</sub>	200	mW
Storage Temp. Range	T <sub>stg</sub>	-65 to +150	°C
Lead Temperature (10 sec.)	TL	260	°C

**Caution** The absolute maximum ratings are rated values exceeding which the product could suffer physical damage. These values must therefore not be exceeded under any conditions.

■ **Recommended Operating Conditions**

Parameter	Symbol	Standard	Unit
Power Voltage	V <sub>CC</sub>	1 to 3.6	V
Input Voltage	V <sub>IN</sub>	0 to 3.6	V
Output Voltage	V <sub>OUT</sub>	0 to V <sub>CC</sub>	V
Op. Temp. Range	Topr	-40 to +85	°C
Input Rise and Fall Time	dt/dv	0 to 1000 (V <sub>CC</sub> =1.0 V)	ns
		0 to 500 (V <sub>CC</sub> =2.0 V)	
		0 to 400 (V <sub>CC</sub> =3.0 V)	

■ **DC Characteristics**

Parameter	Symbol	Conditions	Ta=25°C			Ta=-40 to 85°C		Unit				
			V <sub>CC</sub>	MIN.	TYP.	MAX.	MIN.		MAX.			
Input Voltage	"H" level	V <sub>IH</sub>	1.0	0.75	—	—	0.75	—	V			
			1.5	1.05	—	—	1.05	—				
			3.0	2.10	—	—	2.10	—				
	"L" level		V <sub>IL</sub>	1.0	—	—	0.25	—		0.25		
				1.5	—	—	0.45	—		0.45		
				3.0	—	—	0.90	—		0.90		
Output Voltage	"H" level	V <sub>OH</sub>		V <sub>IN</sub> =V <sub>IH</sub> or V <sub>IL</sub>	I <sub>OH</sub> =-20 μA	1.0	0.9	1.0	—	0.9	—	V
						1.5	1.4	1.5	—	1.4	—	
					3.0	2.9	3.0	—	2.9	—		
			I <sub>OH</sub> =-1 mA		1.5	1.07	1.23	—	0.99	—		
	I <sub>OH</sub> =-2.6 mA		3.0	2.61	2.68	—	2.55	—				
	"L" level		V <sub>OL</sub>	V <sub>IN</sub> =V <sub>IH</sub>	I <sub>OL</sub> =20 μA	1.0	—	0	0.1	—	0.1	
						1.5	—	0	0.1	—	0.1	
					3.0	—	0	0.1	—	0.1		
					I <sub>OL</sub> =1 mA	1.5	—	0.23	0.31	—	0.37	
					I <sub>OL</sub> =2.6 mA	3.0	—	0.23	0.31	—	0.33	
Input Current		I <sub>IN</sub>			V <sub>IN</sub> =V <sub>CC</sub> or GND	3.6	—	—	±0.1	—	±1.0	μA
Current Consump.	I <sub>CC</sub>	V <sub>IN</sub> =V <sub>CC</sub> or GND		3.6	—	—	1.0	—	10.0	μA		

■ AC Characteristics

$C_L=15$  pf, Input  $t_r=t_f=6$  ns,  $V_{CC}=3.3\pm 0.3$  V,  $T_a=25^\circ\text{C}$  (unless otherwise specified)

Parameter	Symbol	Measurement Conditions	MIN.	TYP.	MAX.	Unit
Output Rise/Fall Time	$t_{TLH}, t_{THL}$		—	4.0	8.5	ns
Propagation Delay Time	$t_{PLH}, t_{PHL}$		—	6.0	9.0	

$C_L=25$  pf, Input  $t_r=t_f=6$  ns (unless otherwise specified)

Parameter	Symbol	Measurement Conditions	$T_a=25^\circ\text{C}$			$T_a=-40$ to $85^\circ\text{C}$		Unit	
			$V_{CC}(\text{V})$	Min.	Typ.	Max.	Min.		Max.
Output Rise/Fall Time	$t_{TLH}, t_{THL}$		1.0	—	35	70	—	90	ns
			1.5	—	15	25	—	30	
			3.0	—	7	10	—	14	
Propagation Delay Time	$t_{PLH}, t_{PHL}$		1.0	—	30	60	—	75	ns
			1.5	—	15	25	—	30	
			3.0	—	7	10	—	14	
Input Capacitance	$C_{IN}$		—	5	10	—	10	pF	
Equiv.Int. Capacitance	$C_{PD}$	Note <sup>1</sup>	—	10	—	—	—	pF	

Note<sup>1</sup>  $C_{PD}$  is the no-load equivalent capacitance inside the circuitry. Refer to the measurement circuit shown below.

Current consumption is averaged by the following equation.

$$I_{CC(opr)} = C_{PD} \cdot V_{CC} \cdot f_{in} + I_{CC}$$

Measurement Circuit

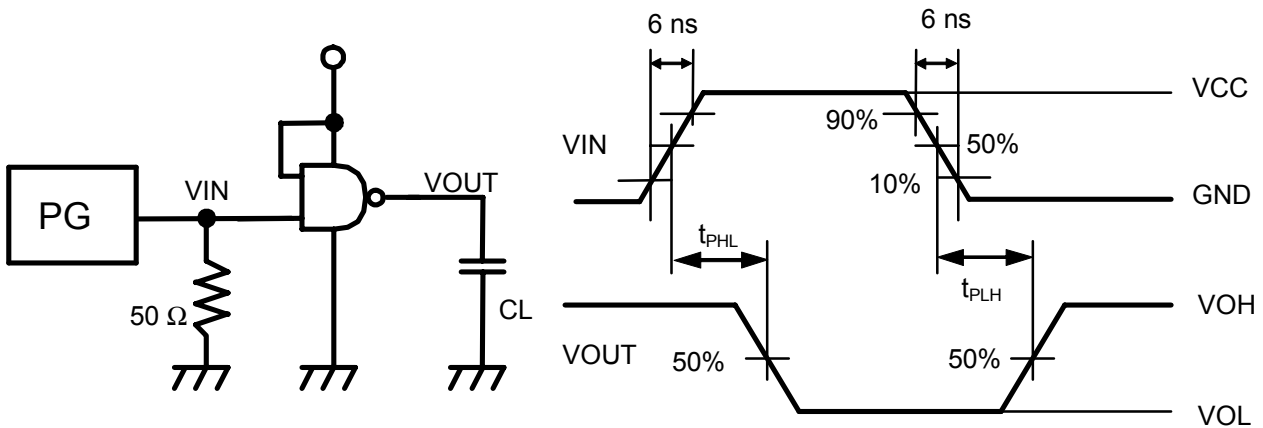

**Remark** No-load output during measurement of current consumption.

■ Input Pin Equivalent Circuit

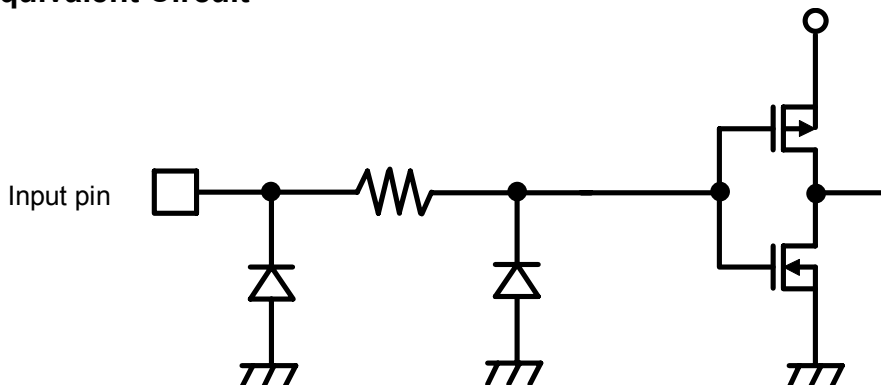

**MINI LOGIC SERIES  
2 INPUT NOR GATE**

**S-75L02ANC**

The S-75L02ANC is a single 2-input NOR gate fabricated by utilizing advanced silicon-gate CMOS technology which provides the inherent benefit of CMOS low power consumption to achieve operation by only a couple of batteries (1 to 3 V).

The internal circuitry has buffered outputs to ensure high noise immunity and output stability.

Input voltage is allowed to be applied even if power voltage is not supplied because no diode is inserted between an input pin and  $V_{CC}$ .

This allows for interfaces between power supplies of different voltage, output level conversion from 3 V to 1 V and battery backup applications.

■ **Features**

- Wide power supply range: 1 V to 3.6 V
- Low current consumption: 1.0  $\mu$ A max. (at 3.6 V, 25°C)
- Typical propagation delay:  $t_{PD} = 7$  ns (at 3 V)
- High noise immunity:  $V_{NIH}=V_{NIL}=28\% V_{CC}$  min.
- Power down protection: All pins
- Very small plastic package: SC-88A

■ **Applications**

- Personal computers, peripherals
- Cellular phones
- Cameras
- Games

■ **Pin Assignment**

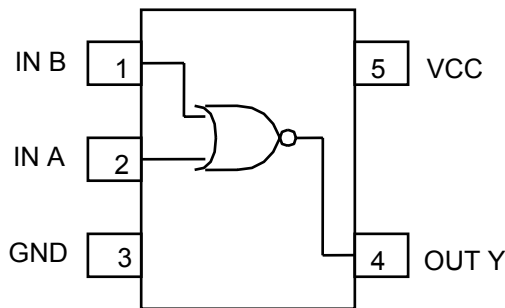

(Top view)

■ **Marking**

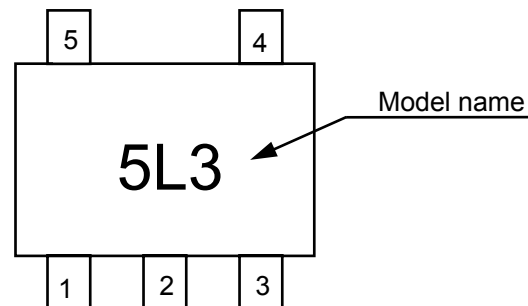

(Top view)

■ **Logic Diagram**

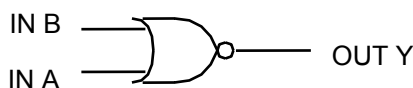

True Values

A	B	Y
L	L	H
L	H	L
H	L	L
H	H	L

## ■ Ordering

Delivery form: Taping only  
Model name: S-75L02ANC-5L3-TF

## ■ Absolute Maximum Ratings

Ta=25°C

Item	Symbol	Ratings	Unit
Power Supply Voltage	V <sub>CC</sub>	-0.5 to +5.0	V
Input Voltage	V <sub>IN</sub>	-0.5 to +5.0	V
Output Voltage	V <sub>OUT</sub>	-0.5 to V <sub>CC</sub> +0.5	V
Input Parasitic Diode Current	I <sub>IK</sub>	-20	mA
Output Parasitic Diode Current	I <sub>OK</sub>	±20	mA
Output Current	I <sub>OUT</sub>	±12.5	mA
V <sub>CC</sub> /GND Current	I <sub>CC</sub>	±25	mA
Power Dissipation	P <sub>D</sub>	200	mW
Storage Temp. Range	T <sub>stg</sub>	-65 to +150	°C
Lead Temperature (10 sec.)	TL	260	°C

**Caution** The absolute maximum ratings are rated values exceeding which the product could suffer physical damage. These values must therefore not be exceeded under any conditions.

## ■ Recommended Operating Conditions

Parameter	Symbol	Standard	Unit
Power Voltage	V <sub>CC</sub>	1 to 3.6	V
Input Voltage	V <sub>IN</sub>	0 to 3.6	V
Output Voltage	V <sub>OUT</sub>	0 to V <sub>CC</sub>	V
Op. Temp. Range	T <sub>opr</sub>	-40 to +85	°C
Input Rise and Fall Time	dt/dv	0 to 1000 (V <sub>CC</sub> =1.0 V)	ns
		0 to 500 (V <sub>CC</sub> =2.0 V)	
		0 to 400 (V <sub>CC</sub> =3.0 V)	

## ■ DC Characteristics

Parameter	Symbol	Conditions	Ta=25°C			Ta=-40 to 85°C		Unit							
			V <sub>CC</sub>	MIN.	TYP.	MAX.	MIN.		MAX.						
Input Voltage	"H" level	V <sub>IH</sub>	1.0	0.75	—	—	0.75	—	V						
			1.5	1.05	—	—	1.05	—							
			3.0	2.10	—	—	2.10	—							
	"L" level		V <sub>IL</sub>	1.0	—	—	0.25	—		0.25					
				1.5	—	—	0.45	—		0.45					
				3.0	—	—	0.90	—		0.90					
Output Voltage	"H" level	V <sub>OH</sub>		V <sub>IN</sub> =V <sub>IL</sub>	I <sub>OH</sub> =-20 μA	1.0	0.9	1.0	—	0.9	—	V			
						1.5	1.4	1.5	—	1.4	—				
						3.0	2.9	3.0	—	2.9	—				
			I <sub>OH</sub> =-1 mA		1.5	1.07	1.23	—	0.99	—					
					I <sub>OH</sub> =-2.6 mA	3.0	2.61	2.68	—	2.55	—				
						1.0	—	0	0.1	—	0.1				
	"L" level	V <sub>OL</sub>	V <sub>IN</sub> =V <sub>IL</sub> or V <sub>IH</sub>	I <sub>OL</sub> =20 μA		1.5	—	0	0.1	—	0.1				
					3.0	—	0	0.1	—	0.1					
					1.5	—	0.23	0.31	—	0.37					
				I <sub>OL</sub> =2.6 mA	3.0	—	0.23	0.31	—	0.33					
					Input Current	I <sub>IN</sub>	V <sub>IN</sub> =V <sub>CC</sub> or GND	3.6	—	—	±0.1		—	±1.0	μA
					Current Consump.	I <sub>CC</sub>	V <sub>IN</sub> =V <sub>CC</sub> or GND	3.6	—	—	1.0		—	10.0	μA

**AC Characteristics**

$C_L=15$  pf, Input  $t_r=t_f=6$  ns,  $V_{CC}=3.3\pm 0.3$  V,  $T_a=25^\circ\text{C}$  (unless otherwise specified)

Parameter	Symbol	Measurement Conditions	MIN.	TYP.	MAX.	Unit
Output Rise/Fall Time	$t_{TLH}, t_{THL}$		—	4.0	8.0	ns
Propagation Delay Time	$t_{PLH}, t_{PHL}$		—	6.0	9.0	

$C_L=25$  pf, Input  $t_r=t_f=6$  ns (unless otherwise specified)

Parameter	Symbol	Measurement Conditions	$T_a=25^\circ\text{C}$			$T_a=-40$ to $85^\circ\text{C}$		Unit	
			$V_{CC}(\text{V})$	Min.	Typ.	Max.	Min.		Max.
Output Rise/Fall Time	$t_{TLH}, t_{THL}$		1.0	—	35	70	—	90	ns
			1.5	—	15	25	—	30	
			3.0	—	7	10	—	14	
Propagation Delay Time	$t_{PLH}, t_{PHL}$		1.0	—	30	60	—	75	ns
			1.5	—	15	25	—	30	
			3.0	—	7	10	—	14	
Input Capacitance	$C_{IN}$		—	5	10	—	10	pF	
Equiv. Int. Capacitance	$C_{PD}$	Note <sup>1</sup>	—	10	—	—	—	pF	

Note<sup>1</sup>  $C_{PD}$  is the no-load equivalent capacitance inside the circuitry. Refer to the measurement circuit shown below.

Current consumption is averaged by the following equation.

$$I_{CC(opr)} = C_{PD} \cdot V_{CC} \cdot f_{in} + I_{CC}$$

**Measurement Circuit**

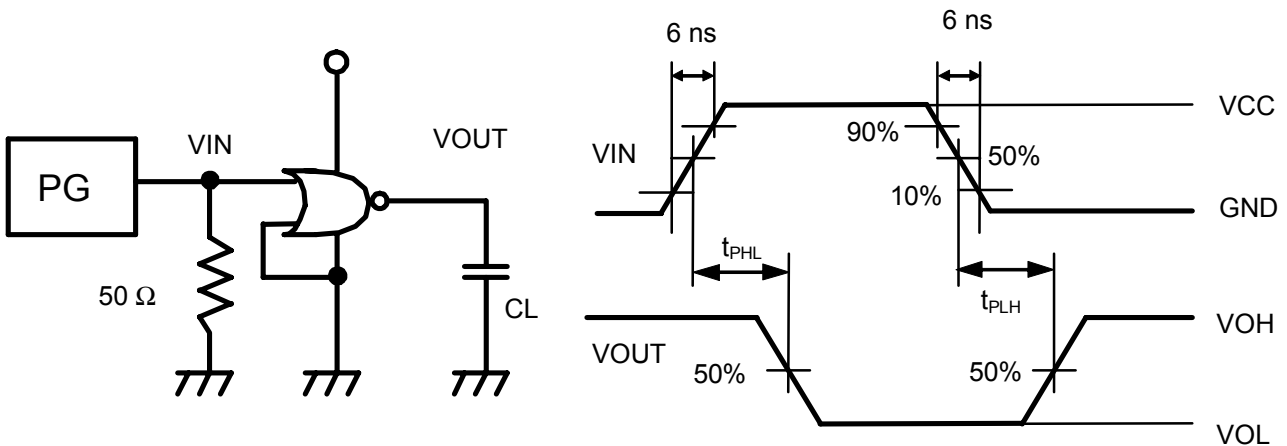

**Remark** No-load output during measurement of current consumption.

**Input Pin Equivalent Circuit**

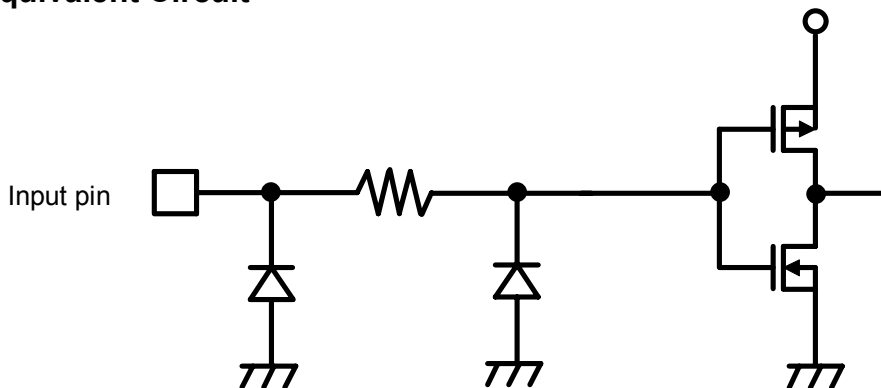

**MINI LOGIC SERIES  
INVERTER**

**S-75L04ANC**

The S-75L04ANC is an inverter fabricated by utilizing advanced silicon-gate CMOS technology which provides the inherent benefit of CMOS low power consumption to achieve operation by only a couple of batteries (1 to 3 V).

The internal circuitry has buffered outputs to ensure high noise immunity and output stability.

Input voltage is allowed to be applied even if power voltage is not supplied because no diode is inserted between an input pin and  $V_{CC}$ .

This allows for interfaces between power supplies of different voltage, output level conversion from 3 V to 1 V and battery backup applications.

■ **Features**

- Wide power supply range: 1 V to 3.6 V
- Low current consumption: 1.0  $\mu$ A max. (at 3.6 V, 25°C)
- Typical propagation delay:  $t_{PD} = 7$  ns (at 3 V)
- High noise immunity:  $V_{NIH}=V_{NIL}=28\%$   $V_{CC}$  min.
- Power down protection: All pins
- Very small plastic package: SC-88A

■ **Applications**

- Personal computers, peripherals
- Cellular phones
- Cameras
- Games

■ **Pin Assignment**

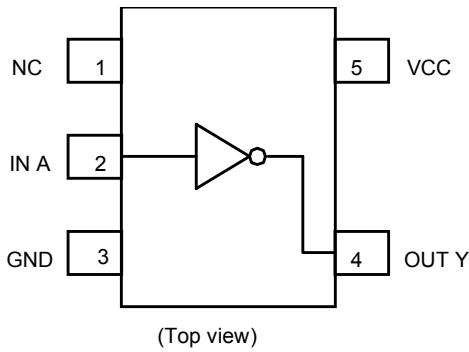

■ **Marking**

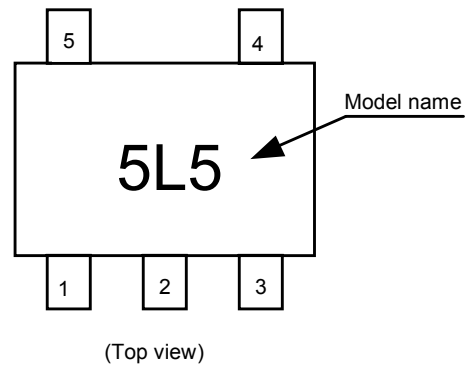

■ **Logic Diagram**

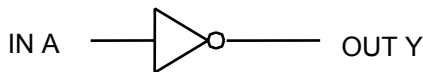

True Values

A	Y
L	H
H	L

■ **Ordering**

Delivery form: Taping only  
 Model name: S-75L04ANC-5L5-TF

■ **Absolute Maximum Ratings**

Ta=25°C

Item	Symbol	Ratings	Unit
Power Supply Voltage	V <sub>CC</sub>	-0.5 to +5.0	V
Input Voltage	V <sub>IN</sub>	-0.5 to +5.0	V
Output Voltage	V <sub>OUT</sub>	-0.5 to V <sub>CC</sub> +0.5	V
Input Parasitic Diode Current	I <sub>IK</sub>	-20	mA
Output Parasitic Diode Current	I <sub>OK</sub>	±20	mA
Output Current	I <sub>OUT</sub>	±12.5	mA
V <sub>CC</sub> /GND Current	I <sub>CC</sub>	±25	mA
Power Dissipation	P <sub>D</sub>	200	mW
Storage Temp. Range	T <sub>stg</sub>	-65 to +150	°C
Lead Temperature (10 sec.)	TL	260	°C

**Caution** The absolute maximum ratings are rated values exceeding which the product could suffer physical damage. These values must therefore not be exceeded under any conditions.

■ **Recommended Operating Conditions**

Parameter	Symbol	Standard	Unit
Power Voltage	V <sub>CC</sub>	1 to 3.6	V
Input Voltage	V <sub>IN</sub>	0 to 3.6	V
Output Voltage	V <sub>OUT</sub>	0 to V <sub>CC</sub>	V
Op. Temp. Range	Topr	-40 to +85	°C
Input Rise and Fall Time	dt/dv	0 to 1000 (V <sub>CC</sub> =1.0 V)	ns
		0 to 500 (V <sub>CC</sub> =2.0 V)	
		0 to 400 (V <sub>CC</sub> =3.0 V)	

■ **DC Characteristics**

Parameter	Symbol	Conditions	Ta=25°C			Ta=-40 to 85°C		Unit					
			V <sub>CC</sub>	MIN.	TYP.	MAX.	MIN.		MAX.				
Input Voltage	"H" level	V <sub>IH</sub>	1.0	0.75	—	—	0.75	—	V				
			1.5	1.05	—	—	1.05	—					
			3.0	2.10	—	—	2.10	—					
	"L" level		V <sub>IL</sub>	1.0	—	—	0.25	—		0.25			
				1.5	—	—	0.45	—		0.45			
				3.0	—	—	0.90	—		0.90			
Output Voltage	"H" level	V <sub>OH</sub>		V <sub>IN</sub> =V <sub>IL</sub>	I <sub>OH</sub> =-20 μA	1.0	0.9	1.0	—	0.9	—	V	
						1.5	1.4	1.5	—	1.4	—		
						3.0	2.9	3.0	—	2.9	—		
			I <sub>OH</sub> =-1 mA			1.5	1.07	1.23	—	0.99	—		
						3.0	2.61	2.68	—	2.55	—		
	"L" level		V <sub>OL</sub>	V <sub>IN</sub> =V <sub>IH</sub>	I <sub>OL</sub> =20 μA	1.0	—	0	0.1	—	0.1		
						1.5	—	0	0.1	—	0.1		
						3.0	—	0	0.1	—	0.1		
						I <sub>OL</sub> =1 mA	1.5	—	0.23	0.31	—		0.37
							3.0	—	0.23	0.31	—		0.33
Input Current	I <sub>IN</sub>	V <sub>IN</sub> =V <sub>CC</sub> or GND		3.6	—	—	±0.1	—	±1.0	μA			
Current Consump.	I <sub>CC</sub>	V <sub>IN</sub> =V <sub>CC</sub> or GND		3.6	—	—	1.0	—	10.0	μA			

■ AC Characteristics

$C_L=15$  pf, Input  $t_r=t_f=6$  ns,  $V_{CC}=3.3\pm 0.3$  V,  $T_a=25^\circ\text{C}$  (unless otherwise specified)

Parameter	Symbol	Measurement Conditions	MIN.	TYP.	MAX.	Unit
Output Rise/Fall Time	$t_{TLH}, t_{THL}$		—	4.0	8.0	ns
Propagation Delay Time	$t_{PLH}, t_{PHL}$		—	6.0	9.0	

$C_L=25$  pf, Input  $t_r=t_f=6$  ns (unless otherwise specified)

Parameter	Symbol	Measurement Conditions	$T_a=25^\circ\text{C}$			$T_a=-40$ to $85^\circ\text{C}$		Unit	
			$V_{CC}(\text{V})$	Min.	Typ.	Max.	Min.		Max.
Output Rise/Fall Time	$t_{TLH}, t_{THL}$		1.0	—	35	70	—	90	ns
			1.5	—	15	25	—	30	
			3.0	—	7	10	—	14	
Propagation Delay Time	$t_{PLH}, t_{PHL}$		1.0	—	30	60	—	75	ns
			1.5	—	15	25	—	30	
			3.0	—	7	10	—	14	
Input Capacitance	$C_{IN}$		—	5	10	—	10	pF	
Equiv. Int. Capacitance	$C_{PD}$	Note <sup>1</sup>	—	10	—	—	—	pF	

Note<sup>1</sup>  $C_{PD}$  is the no-load equivalent capacitance inside the circuitry. Refer to the measurement circuit shown below.

Current consumption is averaged by the following equation.

$$I_{CC(opr)} = C_{PD} \cdot V_{CC} \cdot f_{in} + I_{CC}$$

Measurement Circuit

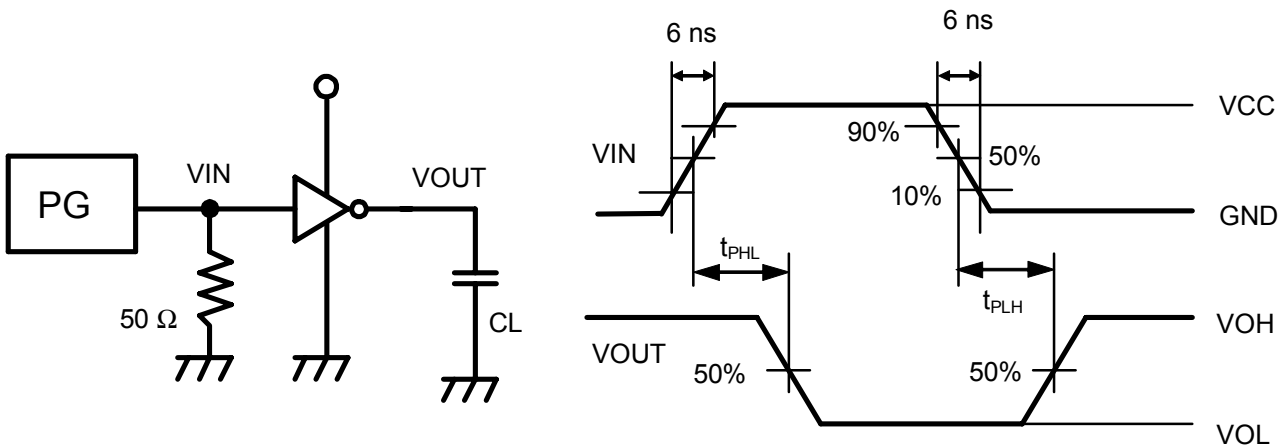

**Remark** No-load output during measurement of current consumption.

■ Input pin Equivalent Circuit

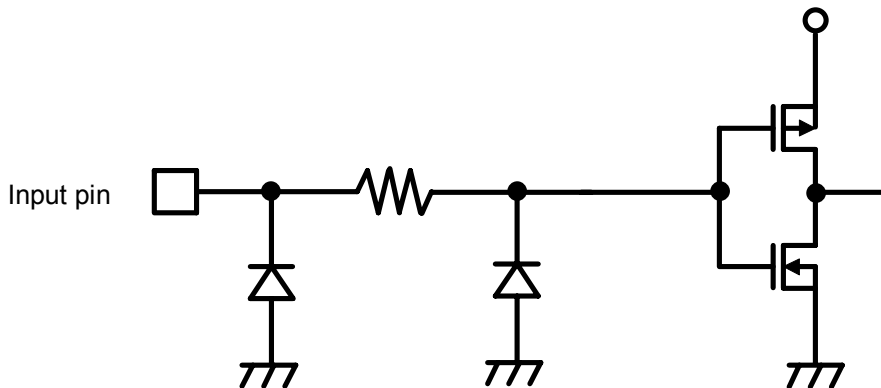

**MINI LOGIC SERIES  
INVERTER (unbuffer)**

**S-75LU04ANC**

The S-75LU04ANC is a single packaged inverter without buffer fabricated by utilizing advanced silicon-gate CMOS technology which provides the inherent benefit of CMOS low power consumption to achieve operation by only a couple of batteries (1 to 3 V).

The S-75LU04ANC is suitable for a wide variety of linear circuits.

Input voltage is allowed to be applied even if power voltage is not supplied because no diode is inserted between an input pin and  $V_{CC}$ .

This allows for interfaces between power supplies of different voltage, output level conversion from 3 V to 1 V and battery backup applications.

■ **Features**

- Wide power supply range: 1 V to 3.6 V
- Low current consumption: 1.0  $\mu$ A max. (at 3.6 V, 25°C)
- Typical propagation delay:  $t_{PD} = 6$  ns (at 3 V)
- High noise immunity:  $V_{NIH} = V_{NIL} = 10\% V_{CC}$  min.
- Power down protection: All pins
- Very small plastic package: SC-88A

■ **Applications**

- Personal computers, peripherals
- Cellular phones
- Cameras
- Games

■ **Pin Assignment**

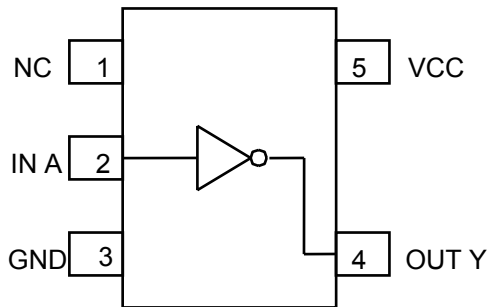

(Top view)

■ **Marking**

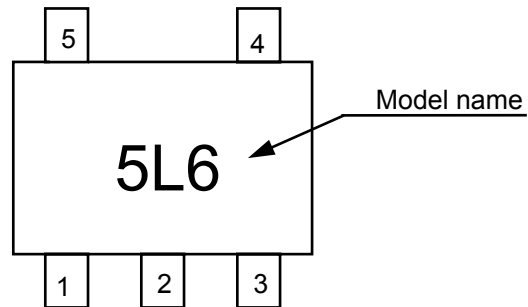

(Top view)

■ **Logic Diagram**

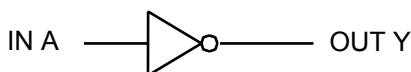

True Values

A	Y
L	H
H	L

## ■ Ordering

Delivery form: Taping only  
Model name: S-75LU04ANC-5L6-TF

## ■ Absolute Maximum Ratings

Ta=25°C			
Item	Symbol	Ratings	Unit
Power Supply Voltage	V <sub>CC</sub>	-0.5 to +5.0	V
Input Voltage	V <sub>IN</sub>	-0.5 to +5.0	V
Output Voltage	V <sub>OUT</sub>	-0.5 to V <sub>CC</sub> +0.5	V
Input Parasitic Diode Current	I <sub>IK</sub>	-20	mA
Output Parasitic Diode Current	I <sub>OK</sub>	±20	mA
Output Current	I <sub>OUT</sub>	±12.5	mA
V <sub>CC</sub> /GND Current	I <sub>CC</sub>	±25	mA
Power Dissipation	P <sub>D</sub>	200	mW
Storage Temp. Range	T <sub>stg</sub>	-65 to +150	°C
Lead Temperature (10 sec.)	TL	260	°C

**Caution** The absolute maximum ratings are rated values exceeding which the product could suffer physical damage. These values must therefore not be exceeded under any conditions.

## ■ Recommended Operating Conditions

Parameter	Symbol	Standard	Unit
Power Voltage	V <sub>CC</sub>	1 to 3.6	V
Input Voltage	V <sub>IN</sub>	0 to 3.6	V
Output Voltage	V <sub>OUT</sub>	0 to V <sub>CC</sub>	V
Op. Temp. Range	T <sub>opr</sub>	-40 to +85	°C
Input Rise and Fall Time	dt/dv	0 to 1000 (V <sub>CC</sub> =1.0 V)	ns
		0 to 500 (V <sub>CC</sub> =2.0 V)	
		0 to 400 (V <sub>CC</sub> =3.0 V)	

## ■ DC Characteristics

Parameter	Symbol	Conditions	Ta=25°C			Ta=-40 to 85°C		Unit							
			V <sub>CC</sub>	MIN.	TYP.	MAX.	MIN.		MAX.						
Input Voltage	"H" level	V <sub>IH</sub>	1.0	0.75	—	—	0.75	—	V						
			1.5	1.05	—	—	1.05	—							
			3.0	2.10	—	—	2.10	—							
	"L" level		V <sub>IL</sub>	1.0	—	—	0.25	—		0.25					
				1.5	—	—	0.45	—		0.45					
				3.0	—	—	0.90	—		0.90					
Output Voltage	"H" level	V <sub>OH</sub>		V <sub>IN</sub> =V <sub>IL</sub>	I <sub>OH</sub> =-20 μA	1.0	0.9	1.0	—	0.9	—	V			
						1.5	1.4	1.5	—	1.4	—				
						3.0	2.9	3.0	—	2.9	—				
			I <sub>OH</sub> =-1 mA		1.5	1.07	1.23	—	0.99	—					
					I <sub>OH</sub> =-2.6 mA	3.0	2.61	2.68	—	2.55	—				
						1.0	—	0	0.1	—	0.1				
	"L" level	V <sub>OL</sub>	V <sub>IN</sub> =V <sub>IH</sub>	I <sub>OL</sub> =20 μA		1.5	—	0	0.1	—	0.1				
					3.0	—	0	0.1	—	0.1					
					1.5	—	0.23	0.31	—	0.37					
				I <sub>OL</sub> =2.6 mA	3.0	—	0.23	0.31	—	0.33					
					Input Current	I <sub>IN</sub>	V <sub>IN</sub> =V <sub>CC</sub> or GND	3.6	—	—	±0.1		—	±1.0	μA
					Current Consump.	I <sub>CC</sub>	V <sub>IN</sub> =V <sub>CC</sub> or GND	3.6	—	—	1.0		—	10.0	μA

■ **AC Characteristics**

$C_L=15$  pf, Input  $t_r=t_f=6$  ns,  $V_{CC}=3.3\pm 0.3$  V,  $T_a=25^\circ\text{C}$  (unless otherwise specified)

Parameter	Symbol	Measurement Conditions	MIN.	TYP.	MAX.	Unit
Output Rise/Fall Time	$t_{TLH}, t_{THL}$		—	6.0	9.0	ns
Propagation Delay Time	$t_{PLH}, t_{PHL}$		—	4.0	10.0	

$C_L=25$  pf, Input  $t_r=t_f=6$  ns (unless otherwise specified)

Parameter	Symbol	Measurement Conditions	$T_a=25^\circ\text{C}$			$T_a=-40$ to $85^\circ\text{C}$		Unit	
			$V_{CC}(\text{V})$	Min.	Typ.	Max.	Min.		Max.
Output Rise/Fall Time	$t_{TLH}, t_{THL}$		1.0	—	35	70	—	90	ns
			1.5	—	15	25	—	30	
			3.0	—	7	10	—	14	
Propagation Delay Time	$t_{PLH}, t_{PHL}$		1.0	—	20	40	—	50	
			1.5	—	10	15	—	20	
			3.0	—	6	9	—	12	
Input Capacitance	$C_{IN}$		—	5	10	—	10	pF	
Equiv. Int. Capacitance	$C_{PD}$	Note <sup>1</sup>	—	10	—	—	—	pF	

Note<sup>1</sup>  $C_{PD}$  is the no-load equivalent capacitance inside the circuitry. Refer to the measurement circuit shown below.

Current consumption is averaged by the following equation.

$$I_{CC(opr)} = C_{PD} \cdot V_{CC} \cdot f_{in} + I_{CC}$$

Measurement Circuit

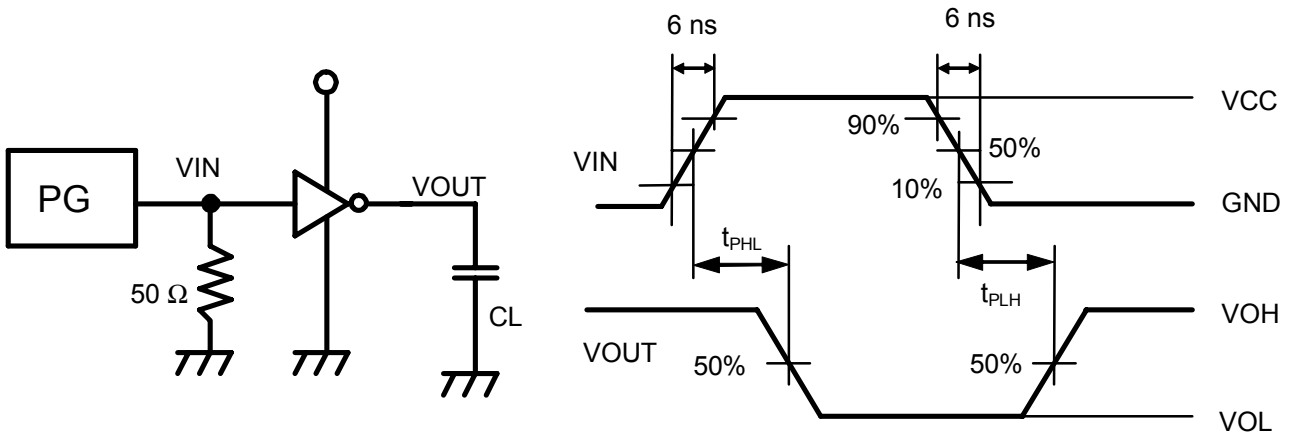

**Remark** No-load output during measurement of current consumption.

■ **Input Pin Equivalent Circuit**

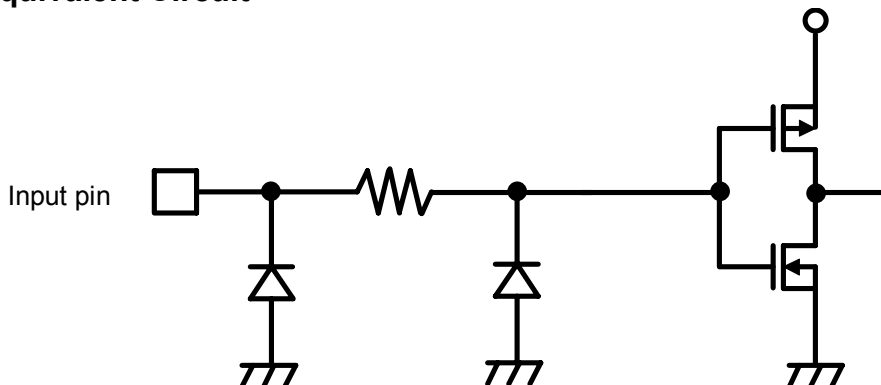

**MINI LOGIC SERIES  
2 INPUT AND GATE**

**S-75L08ANC**

The S-75L08ANC is a single 2-Input AND Gate fabricated by utilizing advanced silicon-gate CMOS technology which provides the inherent benefit of CMOS low power consumption to achieve operation by only a couple of batteries (1 to 3 V).

The internal circuitry has buffered outputs to ensure high noise immunity and output stability.

Input voltage is allowed to be applied even if power voltage is not supplied because no diode is inserted between an input pin and  $V_{CC}$ .

This allows for interfaces between power supplies of different voltage, output level conversion from 3 V to 1 V and battery backup applications.

■ **Features**

- Wide power supply range: 1 V to 3.6 V
- Low current consumption: 1.0  $\mu$ A max. (at 3.6 V, 25°C)
- Typical propagation delay:  $t_{PD} = 7$  ns (at 3 V)
- High noise immunity:  $V_{NIH}=V_{NIL}=28\%$   $V_{CC}$  min.
- Power down protection: All pins
- Very small plastic package: SC-88A

■ **Applications**

- Personal computers, peripherals
- Cellular phones
- Cameras
- Games

■ **Pin Assignment**

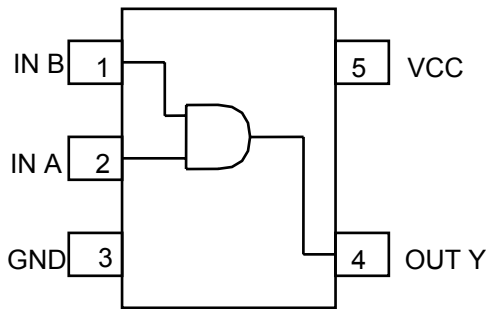

(Top view)

■ **Marking**

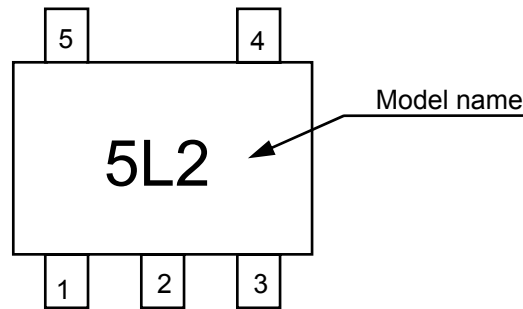

(Top view)

■ **Logic Diagram**

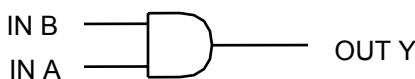

True Values

A	B	Y
L	L	L
L	H	L
H	L	L
H	H	H

■ **Ordering**

Delivery form: Taping only  
 Model name: S-75L08ANC-5L2-TF

■ **Absolute Maximum Ratings**

Ta=25°C

Item	Symbol	Ratings	Unit
Power Supply Voltage	V <sub>CC</sub>	-0.5 to +5.0	V
Input Voltage	V <sub>IN</sub>	-0.5 to +5.0	V
Output Voltage	V <sub>OUT</sub>	-0.5 to V <sub>CC</sub> +0.5	V
Input Parasitic Diode Current	I <sub>IK</sub>	-20	mA
Output Parasitic Diode Current	I <sub>OK</sub>	±20	mA
Output Current	I <sub>OUT</sub>	±12.5	mA
V <sub>CC</sub> /GND Current	I <sub>CC</sub>	±25	mA
Power Dissipation	P <sub>D</sub>	200	mW
Storage Temp. Range	T <sub>stg</sub>	-65 to +150	°C
Lead Temperature (10 sec.)	TL	260	°C

**Caution** The absolute maximum ratings are rated values exceeding which the product could suffer physical damage. These values must therefore not be exceeded under any conditions.

■ **Recommended Operating Conditions**

Parameter	Symbol	Standard	Unit
Power Voltage	V <sub>CC</sub>	1 to 3.6	V
Input Voltage	V <sub>IN</sub>	0 to 3.6	V
Output Voltage	V <sub>OUT</sub>	0 to V <sub>CC</sub>	V
Op. Temp. Range	Topr	-40 to +85	°C
Input Rise and Fall Time	dt/dv	0 to 1000 (V <sub>CC</sub> =1.0 V)	ns
		0 to 500 (V <sub>CC</sub> =2.0 V)	
		0 to 400 (V <sub>CC</sub> =3.0 V)	

■ **DC Characteristics**

Parameter	Symbol	Conditions	Ta=25°C			Ta=-40 to 85°C		Unit					
			V <sub>CC</sub>	MIN.	TYP.	MAX.	MIN.		MAX.				
Input Voltage	"H" level	V <sub>IH</sub>	1.0	0.75	—	—	0.75	—	V				
			1.5	1.05	—	—	1.05	—					
			3.0	2.10	—	—	2.10	—					
	"L" level		V <sub>IL</sub>	1.0	—	—	0.25	—		0.25			
				1.5	—	—	0.45	—		0.45			
				3.0	—	—	0.90	—		0.90			
Output Voltage	"H" level	V <sub>OH</sub>		V <sub>IN</sub> =V <sub>IH</sub>	I <sub>OH</sub> =-20 μA	1.0	0.9	1.0	—	0.9	—	V	
						1.5	1.4	1.5	—	1.4	—		
						3.0	2.9	3.0	—	2.9	—		
			I <sub>OH</sub> =-1 mA			1.5	1.07	1.23	—	0.99	—		
						3.0	2.61	2.68	—	2.55	—		
	"L" level		V <sub>OL</sub>	V <sub>IN</sub> =V <sub>IL</sub> or V <sub>IH</sub>	I <sub>OL</sub> =20 μA	1.0	—	0	0.1	—	0.1		
						1.5	—	0	0.1	—	0.1		
						3.0	—	0	0.1	—	0.1		
						I <sub>OL</sub> =1 mA	1.5	—	0.23	0.31	—		0.37
							3.0	—	0.23	0.31	—		0.33
Input Current	I <sub>IN</sub>	V <sub>IN</sub> =V <sub>CC</sub> or GND			3.6	—	—	±0.1	—	±1.0	μA		
Current Consump.	I <sub>CC</sub>	V <sub>IN</sub> =V <sub>CC</sub> or GND			3.6	—	—	1.0	—	10.0	μA		

**■ AC Characteristics**

$C_L=15\text{ pf}$ , Input  $t_r=t_f=6\text{ ns}$ ,  $V_{CC}=3.3\pm 0.3\text{ V}$ ,  $T_a=25^\circ\text{C}$  (unless otherwise specified)

Parameter	Symbol	Measurement Conditions	MIN.	TYP.	MAX.	Unit
Output Rise/Fall Time	$t_{TLH}, t_{THL}$		—	4.0	8.0	ns
Propagation Delay Time	$t_{PLH}, t_{PHL}$		—	6.0	9.0	

$C_L=25\text{ pf}$ , Input  $t_r=t_f=6\text{ ns}$  (unless otherwise specified)

Parameter	Symbol	Measurement Conditions	$T_a=25^\circ\text{C}$			$T_a=-40\text{ to }85^\circ\text{C}$		Unit	
			$V_{CC}(\text{V})$	Min.	Typ.	Max.	Min.		Max.
Output Rise/Fall Time	$t_{TLH}, t_{THL}$		1.0	—	35	70	—	90	ns
			1.5	—	15	25	—	30	
			3.0	—	7	10	—	14	
Propagation Delay Time	$t_{PLH}, t_{PHL}$		1.0	—	30	60	—	75	ns
			1.5	—	15	25	—	30	
			3.0	—	7	10	—	14	
Input Capacitance	$C_{IN}$		—	5	10	—	10	pF	
Equiv. Int. Capacitance	$C_{PD}$	Note <sup>1</sup>	—	10	—	—	—	pF	

Note<sup>1</sup>  $C_{PD}$  is the no-load equivalent capacitance inside the circuitry. Refer to the measurement circuit shown below.

Current consumption is averaged by the following equation.

$$I_{CC(opr)} = C_{PD} \cdot V_{CC} \cdot f_{in} + I_{CC}$$

**Measurement Circuit**

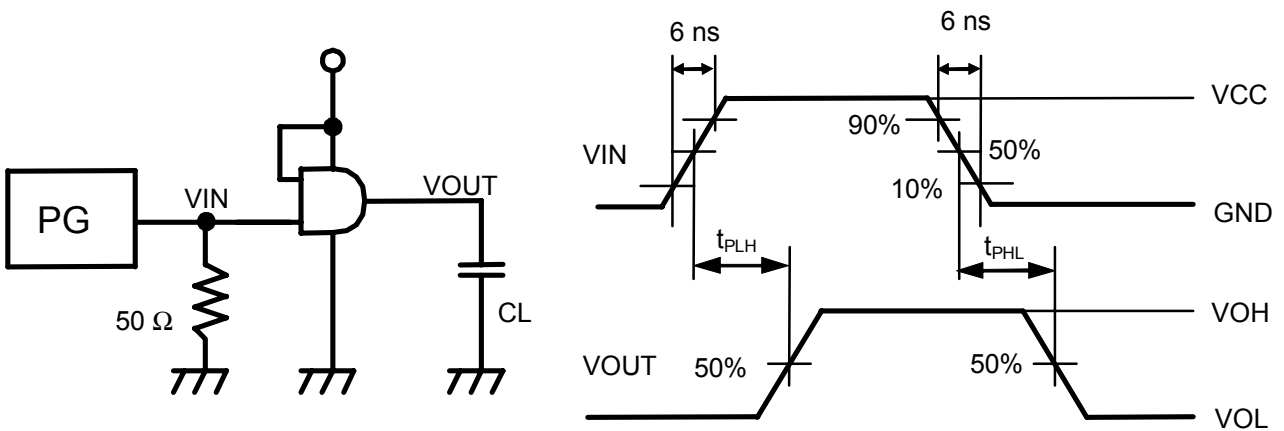

**Remark** No-load output during measurement of current consumption.

**■ Input Pin Equivalent Circuit**

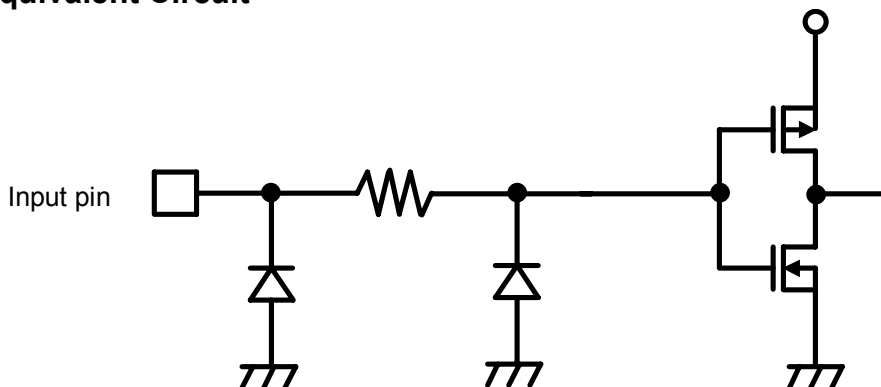

**MINI LOGIC SERIES  
SCHMITT INVERTER**

**S-75L14ANC**

The S-75L14ANC is a SCHMITT INVERTER fabricated by utilizing advanced silicon-gate CMOS technology which provides the inherent benefit of CMOS low power consumption to achieve operation by only a couple of batteries (1 to 3 V).

The internal circuitry has buffered outputs to ensure high noise immunity and output stability.

Input voltage is allowed to be applied even if power voltage is not supplied because no diode is inserted between an input pin and  $V_{CC}$ .

This allows for interfaces between power supplies of different voltage, output level conversion from 3 V to 1 V and battery backup applications.

■ **Features**

- Wide power supply range: 1 V to 3.6 V
- Low current consumption: 1.0  $\mu$ A max. (at 3.6 V, 25°C)
- Typical propagation delay:  $t_{PD} = 8$  ns (at 3 V)
- High noise immunity:  $V_{NIH}=V_{NIL}=28\%$   $V_{CC}$  min.
- Power down protection: All pins
- Very small plastic package: SC-88A

■ **Applications**

- Personal computers, peripherals
- Cellular phones
- Cameras
- Games

■ **Pin Assignment**

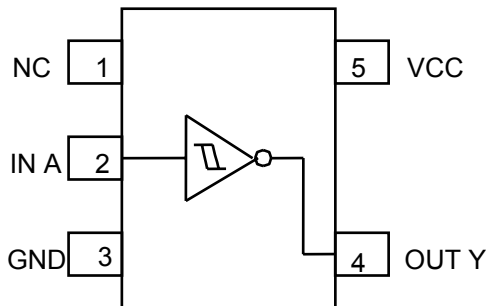

(Top view)

■ **Marking**

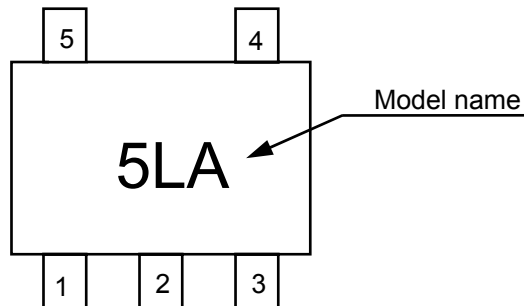

(Top view)

■ **Logic Diagram**

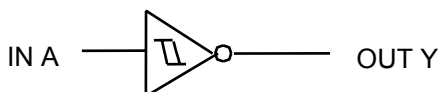

True Values

A	B
L	H
H	L

## Ordering

Delivery form: Taping only  
Model name: S-75L14ANC-5LA-TF

## Absolute Maximum Ratings

Ta=25°C

Item	Symbol	Ratings	Unit
Power Supply Voltage	V <sub>CC</sub>	-0.5 to +5.0	V
Input Voltage	V <sub>IN</sub>	-0.5 to +5.0	V
Output Voltage	V <sub>OUT</sub>	-0.5 to V <sub>CC</sub> +0.5	V
Input Parasitic Diode Current	I <sub>IK</sub>	-20	mA
Output Parasitic Diode Current	I <sub>OK</sub>	±20	mA
Output Current	I <sub>OUT</sub>	±12.5	mA
V <sub>CC</sub> /GND Current	I <sub>CC</sub>	±25	mA
Power Dissipation	P <sub>D</sub>	200	mW
Storage Temp. Range	T <sub>stg</sub>	-65 to +150	°C
Lead Temperature (10 sec.)	TL	260	°C

**Caution** The absolute maximum ratings are rated values exceeding which the product could suffer physical damage. These values must therefore not be exceeded under any conditions.

## Recommended Operating Conditions

Parameter	Symbol	Standard	Unit
Power Voltage	V <sub>CC</sub>	1 to 3.6	V
Input Voltage	V <sub>IN</sub>	0 to 3.6	V
Output Voltage	V <sub>OUT</sub>	0 to V <sub>CC</sub>	V
Op. Temp. Range	Topr	-40 to +85	°C
Input Rise and Fall Time	dt/dv	0 to 1000 (V <sub>CC</sub> =1.0 V)	ns
		0 to 500 (V <sub>CC</sub> =2.0 V)	
		0 to 400 (V <sub>CC</sub> =3.0 V)	

## DC Characteristics

Parameter	Symbol	Conditions	Ta=25°C			Ta=-40 to 85°C		Unit			
			V <sub>CC</sub>	MIN.	TYP.	MAX.	MIN.		MAX.		
Input Voltage	"H" level	V <sub>IH</sub>	1.0	0.80	—	—	0.80	—	V		
			1.5	1.20	—	—	1.20	—			
			3.0	2.10	—	—	2.10	—			
	"L" level	V <sub>IL</sub>	1.0	—	—	0.20	—	0.20			
			1.5	—	—	0.45	—	0.45			
			3.0	—	—	0.90	—	0.90			
Output Voltage	"H" level	V <sub>OH</sub>	V <sub>IN</sub> =V <sub>IL</sub>	I <sub>OH</sub> =-20 μA	1.0	0.9	1.0	—	0.9	—	V
					1.5	1.4	1.5	—	1.4	—	
					3.0	2.9	3.0	—	2.9	—	
				I <sub>OH</sub> =-1 mA	1.5	1.07	1.23	—	0.99	—	
					3.0	2.61	2.68	—	2.55	—	
					I <sub>OH</sub> =-2.6 mA	3.0	2.61	2.68	—	2.55	
	"L" level	V <sub>OL</sub>	V <sub>IN</sub> =V <sub>IH</sub>	I <sub>OL</sub> =20 μA	1.0	—	0	0.1	—	0.1	
					1.5	—	0	0.1	—	0.1	
					3.0	—	0	0.1	—	0.1	
				I <sub>OL</sub> =1 mA	1.5	—	0.23	0.31	—	0.37	
					3.0	—	0.23	0.31	—	0.33	
					I <sub>OL</sub> =2.6 mA	3.0	—	0.23	0.31	—	
Hysteresis Voltage	V <sub>H</sub>		1.0	0.20	—	0.50	—	—	V		
			1.5	0.25	—	0.50	—	—			
			3.0	0.45	—	0.65	—	—			
Input Current	I <sub>IN</sub>	V <sub>IN</sub> =V <sub>CC</sub> or GND	3.6	—	—	±0.1	—	±1.0	μA		
Current Consump.	I <sub>CC</sub>	V <sub>IN</sub> =V <sub>CC</sub> or GND	3.6	—	—	1.0	—	10.0	μA		

■ **AC Characteristics**

$C_L=15$  pf, Input  $t_r=t_f=6$  ns,  $V_{CC}=3.3\pm 0.3$  V,  $T_a=25^\circ\text{C}$  (unless otherwise specified)

Parameter	Symbol	Measurement Conditions	MIN.	TYP.	MAX.	Unit
Output Rise/Fall Time	$t_{TLH}, t_{THL}$		—	4.0	8.0	ns
Propagation Delay Time	$t_{PLH}, t_{PHL}$		—	4.0	10.5	

$C_L=25$  pf, Input  $t_r=t_f=6$  ns (unless otherwise specified)

Parameter	Symbol	Measurement Conditions	$T_a=25^\circ\text{C}$			$T_a=-40$ to $85^\circ\text{C}$		Unit	
			$V_{CC}(\text{V})$	Min.	Typ.	Max.	Min.		Max.
Output Rise/Fall Time	$t_{TLH}, t_{THL}$		1.0	—	35	70	—	90	ns
			1.5	—	15	25	—	30	
			3.0	—	7	10	—	14	
Propagation Delay Time	$t_{PLH}, t_{PHL}$		1.0	—	35	70	—	90	
			1.5	—	15	25	—	30	
			3.0	—	8	12	—	15	
Input Capacitance	$C_{IN}$		—	5	10	—	10	pF	
Equiv.Int. Capacitance	$C_{PD}$	Note <sup>1</sup>	—	10	—	—	—	pF	

Note<sup>1</sup>  $C_{PD}$  is the no-load equivalent capacitance inside the circuitry. Refer to the measurement circuit shown below.

Current consumption is averaged by the following equation.

$$I_{CC(opr)} = C_{PD} \cdot V_{CC} \cdot f_{in} + I_{CC}$$

Measurement Circuit

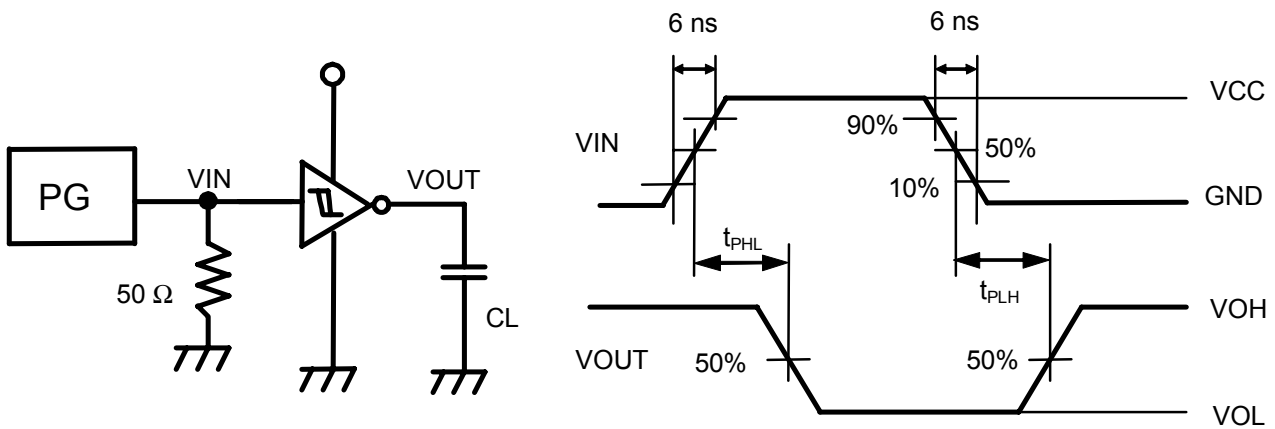

**Remark** No-load output during measurement of current consumption.

■ **Input Pin Equivalent Circuit**

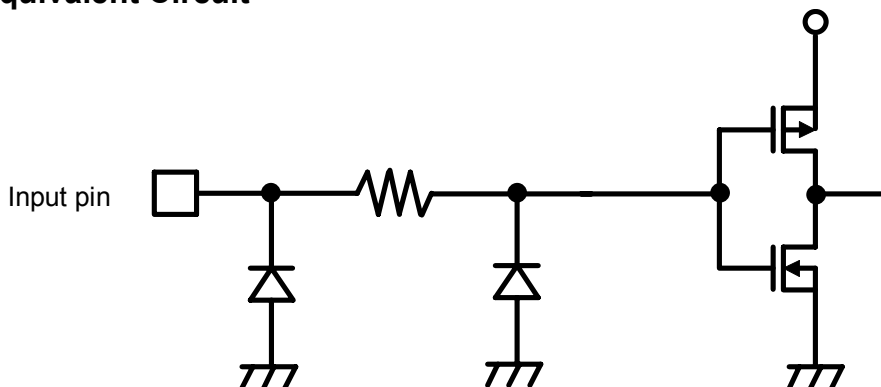

**MINI LOGIC SERIES  
2 INPUT OR GATE**

**S-75L32ANC**

The S-75L32ANC is a single 2-input OR gate fabricated by utilizing advanced silicon-gate CMOS technology which provides the inherent benefit of CMOS low power consumption to achieve operation by only a couple of batteries (1 to 3 V).

The internal circuitry has buffered outputs to ensure high noise immunity and output stability.

Input voltage is allowed to be applied even if power voltage is not supplied because no diode is inserted between an input pin and  $V_{CC}$ .

This allows for interfaces between power supplies of different voltage, output level conversion from 3 V to 1 V and battery backup applications.

■ **Features**

- Wide power supply range: 1 V to 3.6 V
- Low current consumption: 1.0  $\mu$ A max. (at 3.6 V, 25°C)
- Typical propagation delay:  $t_{PD} = 7$  ns (at 3 V)
- High noise immunity:  $V_{NIH} = V_{NIL} = 28\% V_{CC}$  min.
- Power down protection: All pins
- Very small plastic package: SC-88A

■ **Applications**

- Personal computers, peripherals
- Cellular phones
- Cameras
- Games

■ **Pin Assignment**

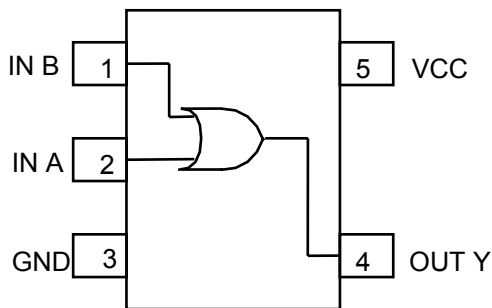

(Top view)

■ **Marking**

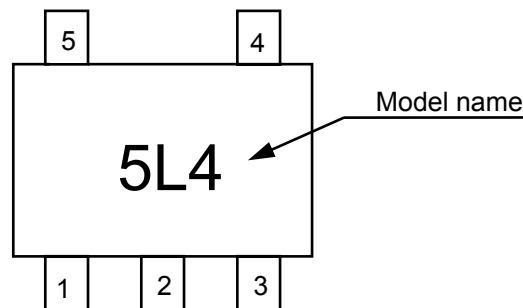

(Top view)

■ **Logic Diagram**

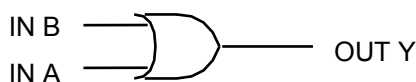

True Values

A	B	Y
L	L	L
L	H	H
H	L	H
H	H	H

■ **Ordering**

Delivery form: Taping only  
 Model name: S-75L32ANC-5L4-TF

■ **Absolute Maximum Ratings**

Ta=25°C

Item	Symbol	Ratings	Unit
Power Supply Voltage	V <sub>CC</sub>	-0.5 to +5.0	V
Input Voltage	V <sub>IN</sub>	-0.5 to +5.0	V
Output Voltage	V <sub>OUT</sub>	-0.5 to V <sub>CC</sub> +0.5	V
Input Parasitic Diode Current	I <sub>IK</sub>	-20	mA
Output Parasitic Diode Current	I <sub>OK</sub>	±20	mA
Output Current	I <sub>OUT</sub>	±12.5	mA
V <sub>CC</sub> /GND Current	I <sub>CC</sub>	±25	mA
Power Dissipation	P <sub>D</sub>	200	mW
Storage Temp. Range	T <sub>stg</sub>	-65 to +150	°C
Lead Temperature (10 sec.)	TL	260	°C

**Caution** The absolute maximum ratings are rated values exceeding which the product could suffer physical damage. These values must therefore not be exceeded under any conditions.

■ **Recommended Operating Conditions**

Parameter	Symbol	Standard	Unit
Power Voltage	V <sub>CC</sub>	1 to 3.6	V
Input Voltage	V <sub>IN</sub>	0 to 3.6	V
Output Voltage	V <sub>OUT</sub>	0 to V <sub>CC</sub>	V
Op. Temp. Range	Topr	-40 to +85	°C
Input Rise and Fall Time	dt/dv	0 to 1000 (V <sub>CC</sub> =1.0 V)	ns
		0 to 500 (V <sub>CC</sub> =2.0 V)	
		0 to 400 (V <sub>CC</sub> =3.0 V)	

■ **DC Characteristics**

Parameter	Symbol	Conditions	Ta=25°C			Ta=-40 to 85°C		Unit					
			V <sub>CC</sub>	MIN.	TYP.	MAX.	MIN.		MAX.				
Input Voltage	"H" level	V <sub>IH</sub>	1.0	0.75	—	—	0.75	—	V				
			1.5	1.05	—	—	1.05	—					
			3.0	2.10	—	—	2.10	—					
	"L" level		V <sub>IL</sub>	1.0	—	—	0.25	—		0.25			
				1.5	—	—	0.45	—		0.45			
				3.0	—	—	0.90	—		0.90			
Output Voltage	"H" level	V <sub>OH</sub>		V <sub>IN</sub> =V <sub>IH</sub> or V <sub>IL</sub>	I <sub>OH</sub> =-20 μA	1.0	0.9	1.0	—	0.9	—	V	
						1.5	1.4	1.5	—	1.4	—		
						3.0	2.9	3.0	—	2.9	—		
			I <sub>OH</sub> =-1 mA			1.5	1.07	1.23	—	0.99	—		
						3.0	2.61	2.68	—	2.55	—		
	"L" level		V <sub>OL</sub>	V <sub>IN</sub> =V <sub>IL</sub>	I <sub>OL</sub> =20 μA	1.0	—	0	0.1	—	0.1		
						1.5	—	0	0.1	—	0.1		
						3.0	—	0	0.1	—	0.1		
						I <sub>OL</sub> =1 mA	1.5	—	0.23	0.31	—		0.37
							3.0	—	0.23	0.31	—		0.33
Input Current	I <sub>IN</sub>	V <sub>IN</sub> =V <sub>CC</sub> or GND		3.6	—	—	±0.1	—	±1.0	μA			
Current Consump.	I <sub>CC</sub>	V <sub>IN</sub> =V <sub>CC</sub> or GND		3.6	—	—	1.0	—	10.0	μA			

■ AC Characteristics

$C_L=15$  pf, Input  $t_r=t_f=6$  ns,  $V_{CC}=3.3\pm 0.3$  V,  $T_a=25^\circ\text{C}$  (unless otherwise specified)

Parameter	Symbol	Measurement Conditions	MIN.	TYP.	MAX.	Unit
Output Rise/Fall Time	$t_{TLH}, t_{THL}$		—	4.0	8.0	ns
Propagation Delay Time	$t_{PLH}, t_{PHL}$		—	6.0	9.0	

$C_L=25$  pf, Input  $t_r=t_f=6$  ns (unless otherwise specified)

Parameter	Symbol	Measurement Conditions	$T_a=25^\circ\text{C}$			$T_a=-40$ to $85^\circ\text{C}$		Unit	
			$V_{CC}(\text{V})$	Min.	Typ.	Max.	Min.		Max.
Output Rise/Fall Time	$t_{TLH}, t_{THL}$		1.0	—	35	70	—	90	ns
			1.5	—	15	25	—	30	
			3.0	—	7	10	—	14	
Propagation Delay Time	$t_{PLH}, t_{PHL}$		1.0	—	30	60	—	75	ns
			1.5	—	15	25	—	30	
			3.0	—	7	10	—	14	
Input Capacitance	$C_{IN}$		—	5	10	—	10	pF	
Equiv. Int. Capacitance	$C_{PD}$	Note <sup>1</sup>	—	10	—	—	—	pF	

Note<sup>1</sup>  $C_{PD}$  is the no-load equivalent capacitance inside the circuitry. Refer to the measurement circuit shown below.

Current consumption is averaged by the following equation.

$$I_{CC(opr)} = C_{PD} \cdot V_{CC} \cdot f_{in} + I_{CC}$$

Measurement Circuit

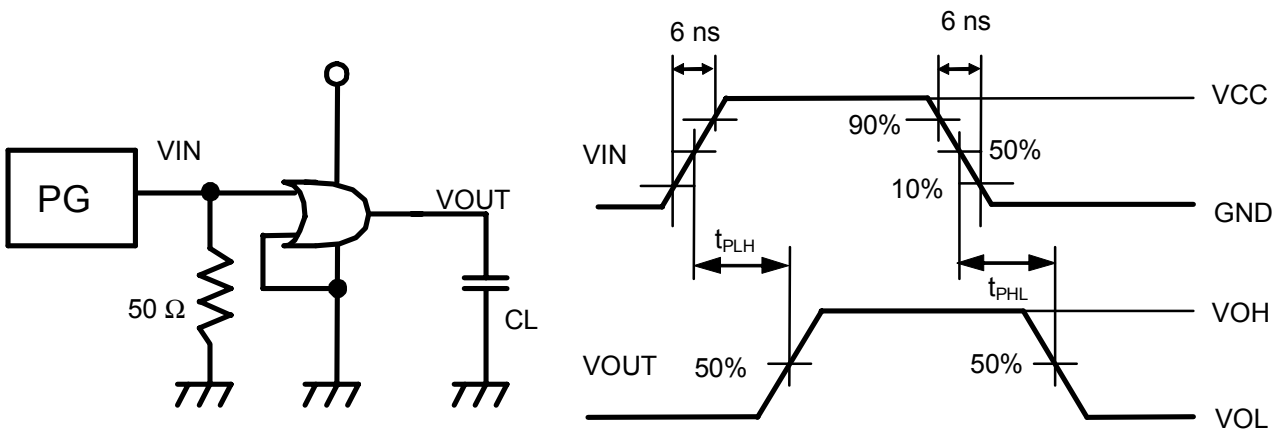

**Remark** No-load output during measurement of current consumption.

■ Input Pin Equivalent Circuit

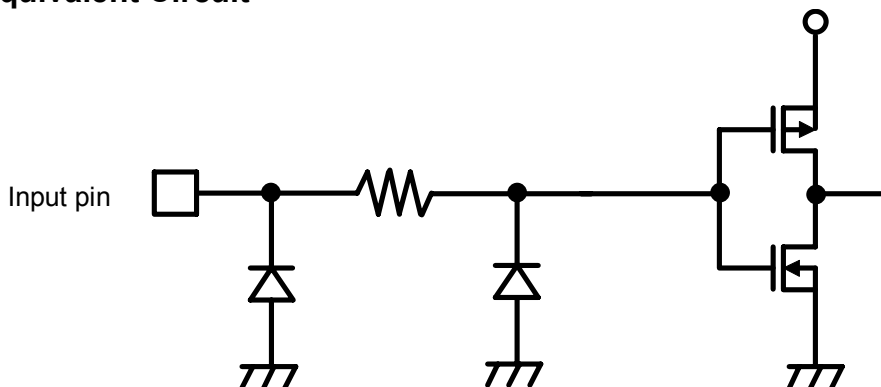

**MINI LOGIC SERIES  
EXCLUSIVE OR GATE**

**S-75L86ANC**

The S-75L86ANC is an EXCLUSIVE OR GATE fabricated by utilizing advanced silicon-gate CMOS technology which provides the inherent benefit of CMOS low power consumption to achieve operation by only a couple of batteries (1 to 3 V).

The internal circuitry has buffered outputs to ensure high noise immunity and output stability.

Input voltage is allowed to be applied even if power voltage is not supplied because no diode is inserted between an input pin and VCC.

This allows for interfaces between power supplies of different voltage, output level conversion from 3 V to 1 V and battery backup applications.

■ **Features**

- Wide power supply range: 1 V to 3.6 V
- Low current consumption: 1.0  $\mu$ A max. (at 3.6 V, 25°C)
- Typical propagation delay:  $t_{PD} = 7$  ns (at 3 V)
- High noise immunity:  $V_{NIH}=V_{NIL}=28\%$   $V_{CC}$  min.
- Power down protection: All pins
- Very small plastic package: SC-88A

■ **Applications**

- Personal computers, peripherals
- Cellular phones
- Cameras
- Games

■ **Pin Assignment**

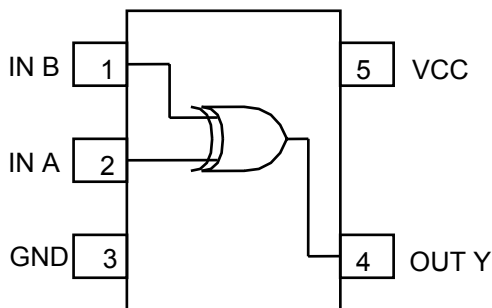

(Top view)

■ **Marking**

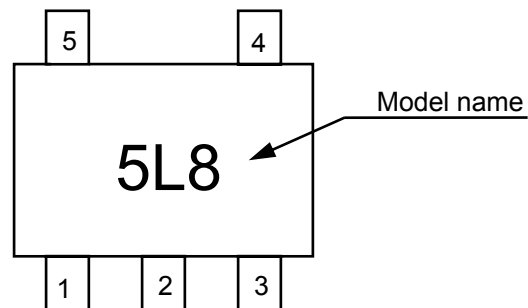

(Top view)

■ **Logic Diagram**

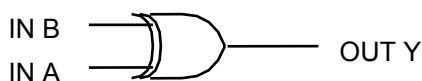

True Values

A	B	Y
L	L	L
L	H	H
H	L	H
H	H	L

## Ordering

Delivery form: Taping only  
Model name: S-75L86ANC-5L8-TF

## Absolute Maximum Ratings

Ta=25°C

Item	Symbol	Ratings	Unit
Power Supply Voltage	V <sub>CC</sub>	-0.5 to +5.0	V
Input Voltage	V <sub>IN</sub>	-0.5 to +5.0	V
Output Voltage	V <sub>OUT</sub>	-0.5 to V <sub>CC</sub> +0.5	V
Input Parasitic Diode Current	I <sub>IK</sub>	-20	mA
Output Parasitic Diode Current	I <sub>OK</sub>	±20	mA
Output Current	I <sub>OUT</sub>	±12.5	mA
V <sub>CC</sub> /GND Current	I <sub>CC</sub>	±25	mA
Power Dissipation	P <sub>D</sub>	200	mW
Storage Temp. Range	T <sub>stg</sub>	-65 to +150	°C
Lead Temperature (10 sec.)	TL	260	°C

**Caution** The absolute maximum ratings are rated values exceeding which the product could suffer physical damage. These values must therefore not be exceeded under any conditions.

## Recommended Operating Conditions

Parameter	Symbol	Standard	Unit
Power Voltage	V <sub>CC</sub>	1 to 3.6	V
Input Voltage	V <sub>IN</sub>	0 to 3.6	V
Output Voltage	V <sub>OUT</sub>	0 to V <sub>CC</sub>	V
Op. Temp. Range	Topr	-40 to +85	°C
Input Rise and Fall Time	dt/dv	0 to 1000 (V <sub>CC</sub> =1.0 V)	ns
		0 to 500 (V <sub>CC</sub> =2.0 V)	
		0 to 400 (V <sub>CC</sub> =3.0 V)	

## DC Characteristics

Parameter	Symbol	Conditions	Ta=25°C			Ta=-40 to 85°C		Unit					
			V <sub>CC</sub>	MIN.	TYP.	MAX.	MIN.		MAX.				
Input Voltage	"H" level	V <sub>IH</sub>	1.0	0.75	—	—	0.75	—	V				
			1.5	1.05	—	—	1.05	—					
			3.0	2.10	—	—	2.10	—					
	"L" level		V <sub>IL</sub>	1.0	—	—	0.25	—		0.25			
				1.5	—	—	0.45	—		0.45			
				3.0	—	—	0.90	—		0.90			
Output Voltage	"H" level	V <sub>OH</sub>		V <sub>IN</sub> =V <sub>IH</sub> or V <sub>IL</sub>	I <sub>OH</sub> =-20 μA	1.0	0.9	1.0	—	0.9	—	V	
						1.5	1.4	1.5	—	1.4	—		
						3.0	2.9	3.0	—	2.9	—		
			I <sub>OH</sub> =-1 mA			1.5	1.07	1.23	—	0.99	—		
						3.0	2.61	2.68	—	2.55	—		
	"L" level		V <sub>OL</sub>	V <sub>IN</sub> =V <sub>IH</sub> or V <sub>IL</sub>	I <sub>OL</sub> =20 μA	1.0	—	0	0.1	—	0.1		
						1.5	—	0	0.1	—	0.1		
						3.0	—	0	0.1	—	0.1		
						I <sub>OL</sub> =1 mA	1.5	—	0.23	0.31	—		0.37
							3.0	—	0.23	0.31	—		0.33
Input Current	I <sub>IN</sub>	V <sub>IN</sub> =V <sub>CC</sub> or GND		3.6	—	—	±0.1	—	±1.0	μA			
Current Consump.	I <sub>CC</sub>	V <sub>IN</sub> =V <sub>CC</sub> or GND		3.6	—	—	1.0	—	10.0	μA			

**AC Characteristics**

$C_L=15$  pf, Input  $t_r=t_f=6$  ns,  $V_{CC}=3.3\pm 0.3$  V,  $T_a=25^\circ\text{C}$  (unless otherwise specified)

Parameter	Symbol	Measurement Conditions	MIN.	TYP.	MAX.	Unit
Output Rise/Fall Time	$t_{TLH}, t_{THL}$		—	4.0	8.0	ns
Propagation Delay Time	$t_{PLH}, t_{PHL}$		—	6.0	9.0	

$C_L=25$  pf, Input  $t_r=t_f=6$  ns (unless otherwise specified)

Parameter	Symbol	Measurement Conditions	$T_a=25^\circ\text{C}$			$T_a=-40$ to $85^\circ\text{C}$		Unit	
			$V_{CC}$ (V)	Min.	Typ.	Max.	Min.		Max.
Output Rise/Fall Time	$t_{TLH}, t_{THL}$		1.0	—	35	70	—	90	ns
			1.5	—	15	25	—	30	
			3.0	—	7	10	—	14	
Propagation Delay Time	$t_{PLH}, t_{PHL}$		1.0	—	30	60	—	75	ns
			1.5	—	15	25	—	30	
			3.0	—	7	10	—	14	
Input Capacitance	$C_{IN}$		—	5	10	—	10	pF	
Equiv. Int. Capacitance	$C_{PD}$	Note <sup>1</sup>	—	10	—	—	—	pF	

Note<sup>1</sup>  $C_{PD}$  is the no-load equivalent capacitance inside the circuitry. Refer to the measurement circuit shown below.

Current consumption is averaged by the following equation.

$$I_{CC(opr)} = C_{PD} \cdot V_{CC} \cdot f_{in} + I_{CC}$$

**Measurement Circuit**

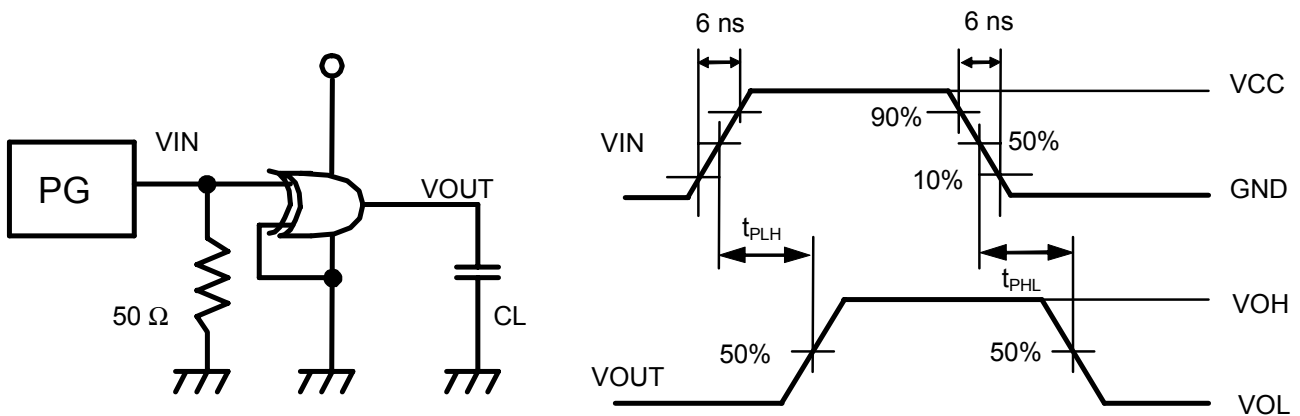

**Remark** No-load output during measurement of current consumption.

**Input Pin Equivalent Circuit**

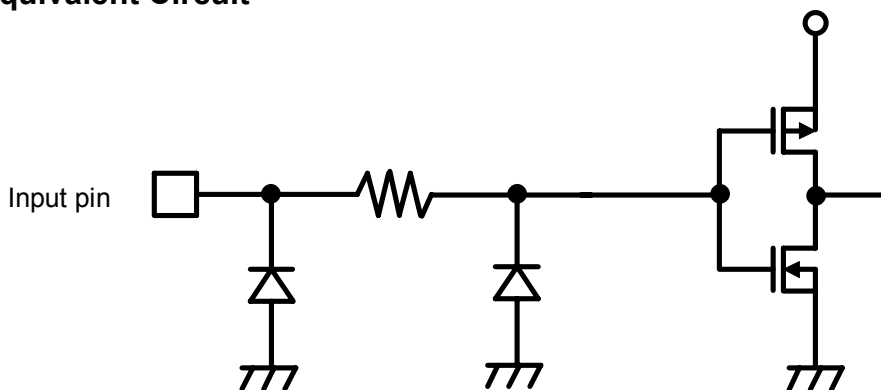

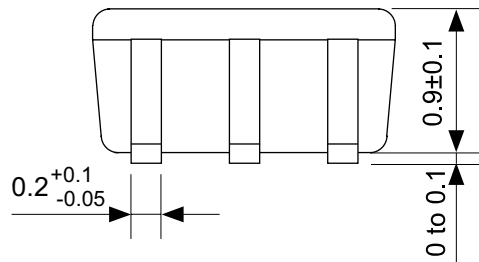
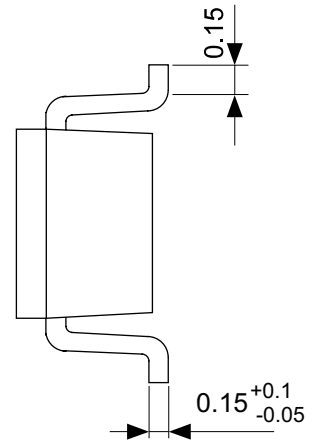
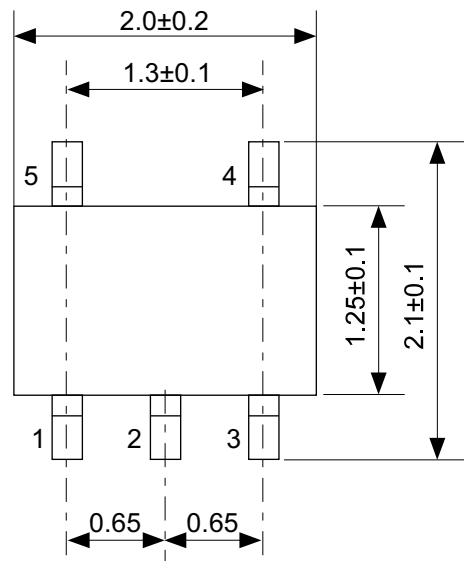

No. NP005-B-P-SD-1.1

TITLE	SC88A-B-PKG Dimensions
No.	NP005-B-P-SD-1.1
SCALE	
UNIT	mm
Seiko Instruments Inc.	

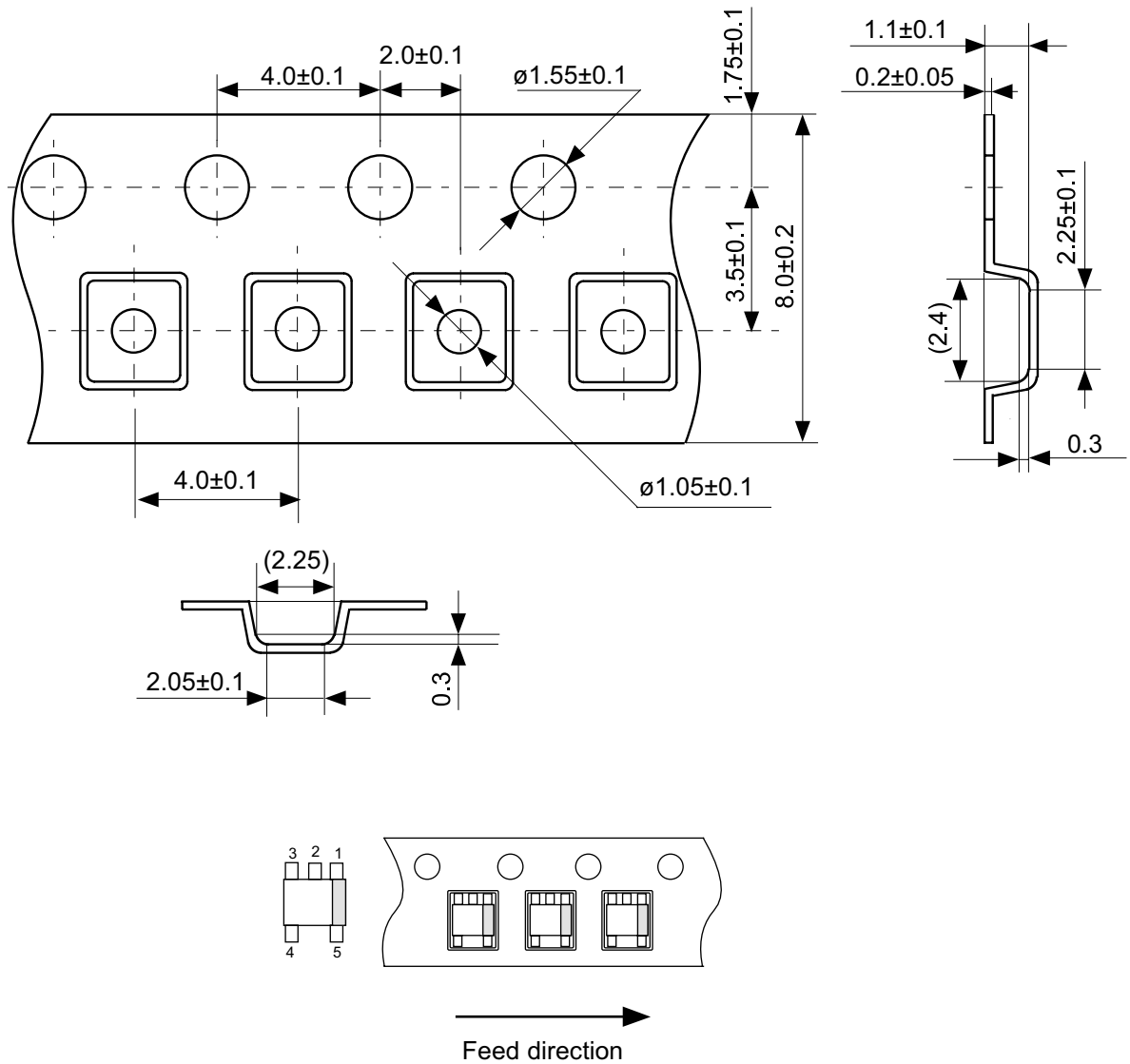

No. NP005-B-C-SD-1.1

TITLE	SC88A-B-Carrier Tape
No.	NP005-B-C-SD-1.1
SCALE	
UNIT	mm
Seiko Instruments Inc.	

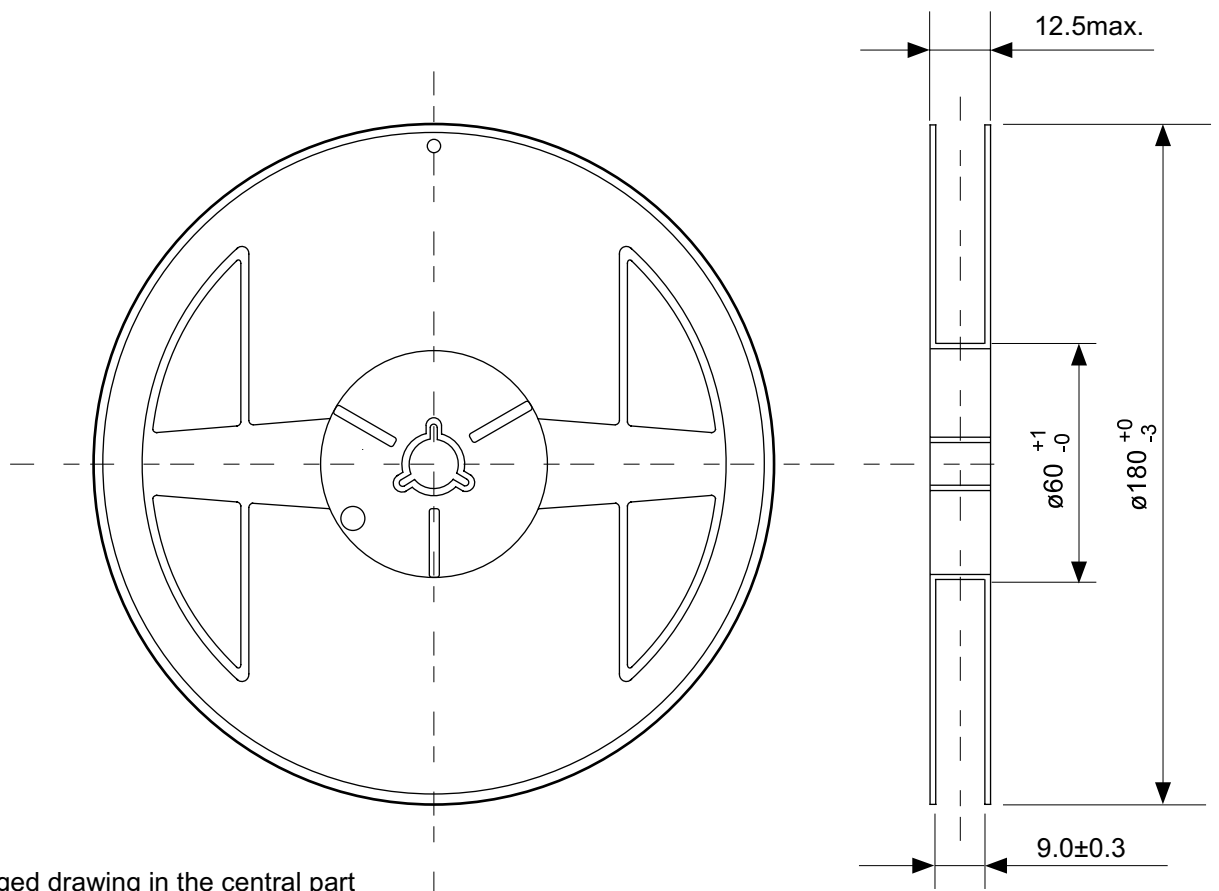

Enlarged drawing in the central part

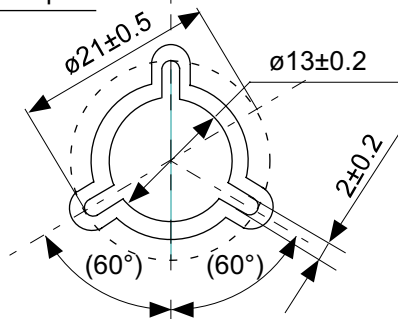

No. NP005-B-R-SD-2.1

TITLE	SC88A-B-Reel		
No.	NP005-B-R-SD-2.1		
SCALE		QTY.	3000
UNIT	mm		
Seiko Instruments Inc.			

- The information described herein is subject to change without notice.
- Seiko Instruments Inc. is not responsible for any problems caused by circuits or diagrams described herein whose related industrial properties, patents, or other rights belong to third parties. The application circuit examples explain typical applications of the products, and do not guarantee the success of any specific mass-production design.
- When the products described herein are regulated products subject to the Wassenaar Arrangement or other agreements, they may not be exported without authorization from the appropriate governmental authority.
- Use of the information described herein for other purposes and/or reproduction or copying without the express permission of Seiko Instruments Inc. is strictly prohibited.
- The products described herein cannot be used as part of any device or equipment affecting the human body, such as exercise equipment, medical equipment, security systems, gas equipment, or any apparatus installed in airplanes and other vehicles, without prior written permission of Seiko Instruments Inc.
- Although Seiko Instruments Inc. exerts the greatest possible effort to ensure high quality and reliability, the failure or malfunction of semiconductor products may occur. The user of these products should therefore give thorough consideration to safety design, including redundancy, fire-prevention measures, and malfunction prevention, to prevent any accidents, fires, or community damage that may ensue.