

# L5PDR



## 7-16 DIN Male Right Angle for 7/8 in LDF5-50A cable

- This product is exclusively available through distribution partners

### OBSOLETE

This product was discontinued on: July 1, 2010

## Product Classification

<b>Product Type</b>	Wireless and radiating connector
<b>Product Brand</b>	HELIAX®

## General Specifications

<b>Body Style</b>	Right angle
<b>Cable Family</b>	LDF5-50A
<b>Inner Contact Attachment Method</b>	Self-tapping
<b>Inner Contact Plating</b>	Silver
<b>Interface</b>	7-16 DIN Male
<b>Mounting Angle</b>	Right angle
<b>Outer Contact Attachment Method</b>	Self-flare
<b>Outer Contact Plating</b>	Trimetal
<b>Pressurizable</b>	No

## Dimensions

<b>Width</b>	36.32 mm   1.43 in
<b>Length</b>	83.82 mm   3.3 in
<b>Right Angle Length</b>	63.5 mm   2.5 in
<b>Diameter</b>	35.56 mm   1.4 in
<b>Nominal Size</b>	7/8 in

# L5PDR

## Outline Drawing

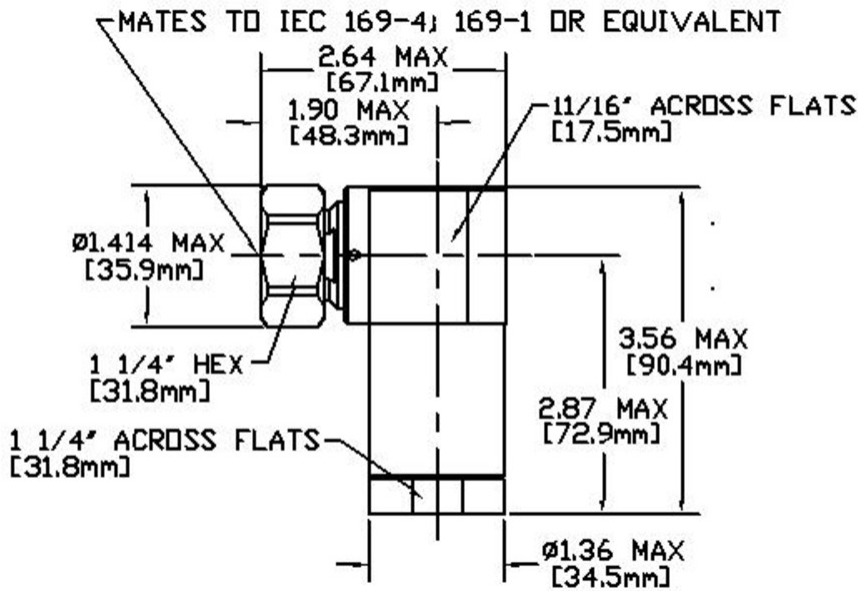

## Electrical Specifications

<b>Insertion Loss, typical</b>	0.05 dB
<b>Average Power at Frequency</b>	2.3 kW @ 900 MHz
<b>Cable Impedance</b>	50 ohm
<b>Connector Impedance</b>	50 ohm
<b>dc Test Voltage</b>	4000 V
<b>Inner Contact Resistance, maximum</b>	0.8 mOhm
<b>Insulation Resistance, minimum</b>	5000 MOhm
<b>Operating Frequency Band</b>	0 – 2000 MHz
<b>Outer Contact Resistance, maximum</b>	1.5 mOhm
<b>Peak Power, maximum</b>	40 kW
<b>RF Operating Voltage, maximum (vrms)</b>	1415 V
<b>Shielding Effectiveness</b>	-130 dB

## Mechanical Specifications

<b>Attachment Durability</b>	25 cycles
<b>Connector Retention Tensile Force</b>	889.64 N   200 lbf
<b>Connector Retention Torque</b>	8.14 N-m   72.001 in lb

# L5PDR

---

<b>Coupling Nut Proof Torque</b>	24.86 N-m   220.003 in lb
<b>Coupling Nut Retention Force</b>	1,000.85 N   225 lbf
<b>Coupling Nut Retention Force Method</b>	MIL-C-39012C-3.23, 4.6.22
<b>Interface Durability</b>	500 cycles
<b>Interface Durability Method</b>	IEC 61169-4:9.5
<b>Mechanical Shock Test Method</b>	MIL-STD-202F, Method 213B, Test Condition C

## Environmental Specifications

<b>Operating Temperature</b>	-55 °C to +85 °C (-67 °F to +185 °F)
<b>Storage Temperature</b>	-55 °C to +85 °C (-67 °F to +185 °F)
<b>Attenuation, Ambient Temperature</b>	20 °C   68 °F
<b>Average Power, Ambient Temperature</b>	40 °C   104 °F
<b>Corrosion Test Method</b>	MIL-STD-1344A, Method 1001.1, Test Condition A
<b>Immersion Depth</b>	1 m
<b>Immersion Test Mating</b>	Mated
<b>Immersion Test Method</b>	IEC 60529:2001, IP68
<b>Moisture Resistance Test Method</b>	MIL-STD-202F, Method 106F
<b>Thermal Shock Test Method</b>	MIL-STD-202F, Method 107G, Test Condition A-1, Low Temperature -55 °C
<b>Vibration Test Method</b>	IEC 60068-2-6
<b>Water Jetting Test Mating</b>	Mated
<b>Water Jetting Test Method</b>	IEC 60529:2001, IP66

## Packaging and Weights

<b>Weight, net</b>	503.5 g   1.11 lb
--------------------	-------------------

## \* Footnotes

<b>Insertion Loss, typical</b>	0.05v <sup>-1</sup> freq (GHz) (not applicable for elliptical waveguide)
<b>Immersion Depth</b>	Immersion at specified depth for 24 hours