

69000

**69000 HiQVideo™
Accelerator with
Integrated Memory**

**Data Sheet
Revision 1.2**

March 1998

P R E L I M I N A R Y

CHIPS®

A SUBSIDIARY OF INTEL CORPORATION

Copyright Notice

Copyright© 1997-98 Chips and Technologies, Inc., a subsidiary of Intel Corporation. ALL RIGHTS RESERVED.

This manual is copyrighted by Chips and Technologies, Inc., a subsidiary of Intel Corporation. You may not reproduce, transmit, transcribe, store in a retrieval system, or translate into any language or computer language, in any form or by any means - electronic, mechanical, magnetic, optical, chemical, manual, or otherwise - any part of this publication without the express written permission of Chips and Technologies, Inc., a subsidiary of Intel Corporation.

Restricted Rights Legend

Use, duplication, or disclosure by the Government is subject to restrictions set forth in subparagraph (c)(1)(ii) of the Rights in Technical Data and Computer Software clause at 252.277-7013.

Trademark Acknowledgment

CHIPS Logo is a registered trademark of Chips and Technologies, Inc., a subsidiary of Intel Corporation.

HiQVideo, is a trademark of Chips and Technologies, Inc., a subsidiary of Intel Corporation.

All other trademarks are the property of their respective holders.

Disclaimer

This document provides general information for the customer. Chips and Technologies, Inc., a subsidiary of Intel Corporation, reserves the right to modify the information contained herein as necessary and the customer should ensure that it has the most recent revision of the document. CHIPS makes no warranty for the use of its products and bears no responsibility for any errors which may appear in this document. The customer should be on notice that many different parties hold patents on products, components, and processes within the personal computer industry. Customers should ensure that their use of the products does not infringe upon any patents. CHIPS respects the patent rights of third parties and shall not participate in direct or indirect patent infringement.

69000 High Performance Flat Panel / CRT HiQVideo™ Accelerator with Integrated Memory

- Highly integrated Flat Panel and CRT GUI Accelerator & Multimedia Engine, Palette/DAC, Clock Synthesizer, and integrated frame buffer
- Integrated High Performance SDRAM memory
 - 2MB integrated memory
 - 83 MHz SDRAM operation
- HiQColor™ Technology implemented with TMED (Temporal Modulated Energy Distribution)
 - Enables 16.7 Million colors on STN panel without *dither*
 - Brighter and Crisper STN Image
 - No shimmer or Mach bands on STN
 - No crawling images on STN
 - 256 gray shades per primary color
 - Panel Tuning NOT required
- Hardware Windows Acceleration
 - 64-bit Graphics Engine
 - System-to-Screen and
 - Screen-to-Screen BitBLT
 - 3-Operand Raster-Ops
 - 8/16/24 Color Expansion
 - Transparent BLT
 - Optimized for Windows™ BitBLT format
 - Acceleration in ALL color modes
- Integrated composite NTSC / PAL Support
 - Flicker Reduction Circuitry
- Hardware Multimedia Support
 - Zoom Video port
 - YUV input from System Bus or Video Port
 - YUV-RGB Conversion
 - Capture / Scaling
 - Video Zoom up to 8x
 - Vertical interpolation of video data up to 720 pixels wide.
 - Double Buffered Video
 - Horizontal Interpolation
 - Image Mirroring
- Display centering and stretching features for optimal fit of VGA graphics and text on 800x600 and 1024x768 panels
- Simultaneous Hardware Cursor and Pop-up Window
 - 64x64 pixels by 4 colors
 - 128x128 pixels by 2 colors
- PCI Bus with Burst Mode capability and BIOS ROM support
- Power Sequencing control outputs regulate application of bias voltage, +5V to the panel and +12V to the inverter for backlight operation.
- 3.3V Operation, 5.0V tolerant I/O
- Game Acceleration
 - Source Transparent BLT
 - Destination Transparent BLT
 - Double buffer support for YUV and 15/16Bpp Overlay Engine
 - Instant Full Screen Page Flip
 - Read back of CRT Scan line counters
- High-Performance Flat Panel Display resolutions and color depth at 3.3V
 - 640x480 x 24bpp
 - 800x600 x 24bpp
 - 1024x768 x 16bpp
 - 1280x1024 x 8bpp
- CRT Support
 - Integrated high performance triple 8-bit, RAMDAC
- Flexible Panel Support
 - Support for a wide variety of monochrome and color panels
 - Single-Panel, Single-Drive (SS)
 - Dual-Panel, Dual Drive (DD) passive STN
 - Active matrix TFT/MIM LCD
 - EL panels
 - Plasma panels
- 36-bit direct interface to color and monochrome, single drive (SS), and dual drive (DD), STN & TFT panels
- Support for 16:9 aspect ratio panels
- Flexible On-chip Activity Timer facilitates ordered shut-down of the display system
- Advanced Power Management feature minimizes power usage in:
 - Normal operation
 - Standby (Sleep) modes
 - Panel-Off Power-Saving Mode
- VESA Standards supported
 - VAFC Port for display of "Live" Video
 - DPMS for CRT power-down
 - DDC for CRT Plug-Play & Display Control
- Fully Compatible with IBM® VGA

69000 Software Support Features

- Drivers Features
 - High Performance Accelerated drivers
 - Compatible across HiQVideo family
 - Auto Panning Support
 - LCD/CRT/Simultaneous Mode Support
 - Auto Resolution Change
 - HW Stretching/Scaling
 - Double Buffering
 - Internationalization
 - ChipsCPL (Control Panel Applet)
 - Direct Draw support
 - Games SDK support
 - Dynamic Resolution Switching
 - VGA Graphics applications in Windows™
 - VESA DDC extensions
 - VESA DPMS extensions
 - Property Sheet to change Refresh/Display
 - Seamless Windows Support
 - Boot time resolution adjustment
 - DIVE, EnDIVE
 - DCAF
- Multimedia Software
 - Video Port Manager for ZV Port
 - PCVideo DLL plus Tuner with DK Board
- Software Utilities
 - DebugVGA
 - Auto testing of all video modes
 - ChipsVGA
 - ChipsEXT
- Software Documentation
 - BIOS OEM Reference Guide
 - Display Driver User's Guide
 - Utilities User's Guide
 - Release Notes for BIOS, Drivers, and Utilities
- Software Support
 - Dedicated Software Applications Engineer
 - BBS Support for Software Updates
- BIOS Features
 - VGA Compatible BIOS
 - PnP Support
 - VESA VBE 2.0 (incl. DPMS)
 - DDC 1, DDC 2AB
 - Text and Graphics Expansion
 - Auto Centering
 - 44 (40) K BIOS
 - CRT, LCD, Simultaneous display modes
 - Auto Resolution Switch
 - Multiple Refresh Rates
 - NTSC/PAL support
 - Extended Modes
 - Extended BIOS Functions
 - 1024x768 TFT, DSTN Color Panels
 - Multiple Panel Support (8 panels built in)
 - Get Panel Type Function
 - HW Popup Interface
 - Monitor Detect
 - Pop Up Support
 - SMI and Hot Key support
- System BIOS Hooks
 - Set Active Display Type
 - Save/Restore Video State
 - Setup Memory for Save/Restore
 - SMI Entry Point
 - Int 15 Calls after POST, Set Mode
- BIOS Modify Program (BMP)
 - Clocks
 - Mode support
 - Panel Tables
 - Int 15 Hooks
 - Monitor Sensing

Revision History

<u>Revision</u>	<u>Date</u>	<u>By</u>	<u>Comments</u>
0.1	2/28/97	TE/lc/bjb	First Draft- Official Release
0.2	4/3/97	AS/bjb	Change MCLK from 110MHz to 83MHz Added HiQColor(features) Updated Pin Descriptions Updated Extension Registers Update Multimedia Registers Updated Electrical Specifications Updated Appendix A
1.0	8/18/97	AS/bjb	Remove NDA requirements and API status
1.1	10/10/97	BB/Inc	Reorganized chapters Added Wide Extension Register chapter Updated Flat Panel Registers Updated CRT Controller Registers Added Subsystem and Subvendor ID support
1.2	3/9/98	BB/Inc	Improved Status Register Descriptions Improved Palette Register Chapter Improved Extension Register Descriptions Improved Flat Panel Register Descriptions Improved Multimedia Register Descriptions Improved BitBLT Engine Register Descriptions Updated Specifications chapter

List Of Figures	xv
List of Tables	xvii
Chapter 1	
Introduction / Overview	
High Performance Integrated Memory	1-1
HiQColor(tm) Technology	1-1
Versatile Panel Support	1-1
Acceleration for All Panels and All Modes	1-1
Television NTSC/PAL Flicker Free Output.....	1-1
HiQvideo(tm) Multimedia Support	1-4
Low Power Consumption	1-5
Software Compatibility/Flexibility.....	1-5
Display Modes Supported	1-5
Chapter 2	
Pin Descriptions	
Pin Diagram, Top View	2-1
Pin Diagram, Bottom View	2-2
PCI Bus Interface	2-3
Configuration Pins and ROM Interface	2-6
Flat Panel Display Interface	2-7
CRT Interface	2-10
Video Interface	2-11
Miscellaneous	2-12
Power and Ground	2-13
Reserved and No Connect	2-14
Chapter 3	
Electrical Specifications	
Absolute Maximum Conditions.....	3-1
Normal Operating Conditions.....	3-1
DAC Characteristics.....	3-1
DC Characteristics	3-2
DC Drive Characteristics.....	3-2
AC Test Conditions	3-3
AC Timing Characterisitcs - Reference Clock.....	3-4
AC Timing Characteristics - Clock Generator	3-4
AC Timing Characteristics - Reset	3-5
AC Timing Characteristics - PCI Bus Frame (CLK=33MHz).....	3-6
AC Timing Characteristics - PCI Bus Stop (CLK=33MHz_	3-7
AC Timing Characteristics - PC BIOS ROM	3-8
AC Timing Characteristics - Video Data Port.....	3-9
AC Timing Characteristics - Panel Output Timing.....	3-10
Chapter 4	
Mechanical Specifications	
	4-1

Chapter 5

I/O and Memory Address Maps

I/O and Memory Address Map	5-1
VGA-Compatible Address Map	5-1
Address Maps for Going Beyond VGA.....	5-2
PCI Configurations Registers	5-3
I/O and Sub-Addressed Register Map	5-4
Sub-Addressing Indexes and Data Ports	5-5
Lower Memory Map	5-6
Upper Memory Map	5-7

Chapter 6

Register Summaries

PCI Configuratin Registers	6-1
CRT Controller Registers	6-2
Sequencer Registers.....	6-3
Graphics Controller Registers.....	6-3
Attribute Controller Registers.....	6-3
Palette Registers.....	6-3
Extension Registers	6-4
Flat Panel Registers.....	6-5
Multimedia Registers.....	6-7
BitBLT Registers	6-8
Memory Mapped Wide Extension Registers.....	6-8

Chapter 7

PCI Configuration Registers

VENDID Vendor ID Register	7-2
DEVID Device ID Register	7-2
DEVCTL Device Control Register	7-3
DEVSTAT Device Status Register	7-5
REV Revision ID Register	7-7
PRG Register-Level Programming Interface Register	7-7
SUB Sub-Class Code Register	7-8
BASE Base Class Code Register	7-8
HDR Header Type Register	7-9
MBASE Memory Base Address Register	7-10
SUBVENDID Subsystem Vendor ID Register	7-11
SUBDEVID Subsystem Device ID Register	7-11
INTLINE Interrupt Line Register.....	7-12
INTPIN Interrupt Pin Register	7-12
RBASE ROM Base Address Register.....	7-13
SUBVENDSET Subsystem Vendor ID Set Register	7-14
SUBDEVSET Subsystem Device ID Set Register	7-14

Chapter 8

General Control and Status Registers

ST00 Input Status Register 0	8-2
ST01 Input Status Register 1	8-3
FCR Feature Control Register	8-4
MSR Miscellaneous Output Register	8-5

Chapter 9

CRT Controller Registers

CRX	CRT Controller Index Register	9-2
CR00	Horizontal Total Register	9-3
CR01	Horizontal Display Enable End Register	9-3
CR02	Horizontal Blanking Start Register	9-3
CR03	Horizontal Blanking End Register	9-5
CR04	Horizontal Sync Start Register	9-6
CR05	Horizontal Sync End Register	9-7
CR06	Vertical Total Register	9-8
CR07	Overflow Register	9-9
CR08	Preset Row Scan Register	9-13
CR09	Maximum Scanline Register	9-14
CR0A	Text Cursor Start Register	9-16
CR0B	Text Cursor End Register	9-17
CR0C	Start Address High Register	9-18
CR0D	Start Address Low Register	9-19
CR0E	Text Cursor Location High Register	9-20
CR0F	Text Cursor Location Low Register	9-20
CR10	Vertical Sync Start Register	9-21
CR11	Vertical Sync End Register	9-22
CR12	Vertical Display Enable End Register	9-23
CR13	Offset Register	9-23
CR14	Underline Location Register	9-24
CR15	Vertical Blanking Start Register	9-25
CR16	Vertical Blanking End Register	9-25
CR17	CRT Mode Control	9-26
CR18	Line Compare Register	9-29
CR22	Memory Read Latch Data Register	9-29
CR30	Extended Vertical Total Register	9-30
CR31	Extended Vertical Display End Register	9-30
CR32	Extended Vertical Sync Start Register	9-31
CR33	Extended Vertical Blanking Start Register	9-32
CR38	Extended Horizontal Total Register	9-33
CR3C	Extended Horizontal Blanking End Register	9-34
CR40	Extended Start Address Register.....	9-35
CR41	Extended Offset Register	9-36
CR70	Interlace Control Register	9-36
CR71	NTSC/PAL Video Output Control Register	9-37
CR72	NTSC/PAL Horizontal Serration 1 Start Register	9-38
CR73	NTSC/PAL Horizontal Serration 2 Start Register	9-38
CR74	NTSC/PAL Horizontal Pulse Width Register	9-39
CR75	NTSC/PAL Filtering Burst Read Length Register	9-40
CR76	NTSC/PAL Filtering Burst Read Quantity Register	9-40
CR77	NTSC/PAL Filtering Control Register	9-41
CR78	NTSC/PAL Vertical Reduction Register.....	9-42
CR79	NTSC/PAL Horizontal Total Fine Adjust Register.....	9-43

Chapter 10**Sequencer Registers**

SRX	Sequencer Index Register	10-2
SR00	Reset Register	10-2
SR01	Clocking Mode Register	10-3
SR02	Plane Mask Register	10-4
SR03	Character Map Select Register	10-5
SR04	Memory Mode Register	10-6
SR07	Horizontal Character Counter Reset Register	10-7

Chapter 11**Graphics Controller Registers**

GRX	Graphics Controller Index Register	11-2
GR00	Set/Reset Register	11-2
GR01	Enable Set/Reset Register	11-3
GR02	Color Compare Register	11-3
GR03	Data Rotate Register	11-4
GR04	Read Plane Select Register	11-5
GR05	Graphics Mode Register	11-6
GR06	Miscellaneous Register	11-9
GR07	Color Don't Care Register	11-10
GR08	Bit Mask Register	11-10

Chapter 12**Attribute Controller Registers**

ARX	Attribute Controller Index Register	12-2
AR00-AR0F	Palette Registers 0-F	12-2
AR10	Mode Control Register	12-3
AR11	Overscan Color Register	12-4
AR12	Memory Plane Enable Register	12-5
AR13	Horizontal Pixel Panning Register	12-6
AR14	Color Select Register	12-7

Chapter 13**Palette Registers**

PALMASK	Palette Data Mask Register	13-3
PALSTATE	Palette State Register	13-3
PALRX	Palette Read Index Register	13-4
PALWX	Palette Write Index Register	13-4
PALDATA	Palette Data Register	13-5

Chapter 14**Extension Registers**

XRX	Extension Register Index Register	14-3
XR00	Vendor ID Low Register	14-3
XR01	Vendor ID High Register	14-4
XR02	Device ID Low Register	14-4
XR03	Device ID High Register	14-5
XR04	Revision ID Register	14-5
XR05	Linear Base Address Low Register	14-6
XR06	Linear Base Address High Register	14-6
XR08	Host Bus Configuration Register	14-7
XR09	I/O Control Register	14-7
XR0A	Frame Buffer Mapping Register	14-8
XR0B	PCI Burst Write Support Register	14-10

XR0E	Frame Buffer Page Select Register	14-11
XR20	BitBLT Configuration Register	14-12
XR40	Memory Access Control Register	14-13
XR41-XR4F	Memory Configuration Registers	14-13
XR60	Video Pin Control Register	14-14
XR61	DPMS Sync Control Register	14-15
XR62	GPIO Pin Control Register	14-16
XR63	GPIO Pin Data Register	14-17
XR67	Pin Tri-State Control Register	14-18
XR70	Configuration Pins 0 Register	14-19
XR71	Configuration Pins 1 Register	14-21
XR80	Pixel Pipeline Configuration 0 Register	14-22
XR81	Pixel Pipeline Configuration 1 Register	14-24
XR82	Pixel Pipeline Configuration 2 Register	14-25
XRA0	Cursor 1 Control Register	14-26
XRA1	Cursor 1 Vertical Extension Register	14-27
XRA2	Cursor 1 Base Address Low Register	14-27
XRA3	Cursor 1 Base Address High Register	14-28
XRA4	Cursor 1 X-Position Low Register	14-28
XRA5	Cursor 1 X-Position High Register	14-29
XRA6	Cursor 1 Y-Position Low Register	14-29
XRA7	Cursor 1 Y-Position High Register	14-30
XRA8	Cursor 2 Control Register	14-31
XRA9	Cursor 2 Vertical Extension Register	14-32
XRAA	Cursor 2 Base Address Low Register	14-32
XRAB	Cursor 2 Base Address High Register	14-33
XRAC	Cursor 2 X-Position Low Register	14-33
XRAD	Cursor 2 X-Position High Register	14-34
XRAE	Cursor 2 Y-Position Low Register	14-34
XRAF	Cursor 2 Y-Position High Register	14-35
XRC0	Dot Clock 0 VCO M-Divisor Low Register	14-35
XRC1	Dot Clock 0 VCO N-Divisor Low Register	14-36
XRC3	Dot Clock 0 Divisor Select Register	14-37
XRC4	Dot Clock 1 VCO M-Divisor Low Register	14-38
XRC5	Dot Clock 1 VCO N-Divisor Low Register	14-38
XRC7	Dot Clock 1 Divisor Select Register	14-39
XRC8	Dot Clock 2 VCO M-Divisor Low Register	14-40
XRC9	Dot Clock 2 VCO N-Divisor Low Register	14-40
XRCB	Dot Clock 2 Divisor Select Register	14-41
XRCC	Memory Clock VCO M-Divisor Register	14-42
XRCD	Memory Clock VCO N-Divisor Register	14-42
XRCE	Memory Clock Divisor Select Register	14-43
XRCF	Clock Configuration Register	14-44
XR0D	Powerdown Control Register	14-45
XR01	Power Conservation Control Register	14-46
XR02	2KHz Down Counter Register	14-46
XRE0-XREB	Software Flag Registers 0 to B	14-47
XRF8-XRFC	Test Registers	14-47

Chapter 15

Flat Panel Registers

FR00	Feature Register	15-2
FR01	CRT / FP Control Register	15-2
FR02	FP Mode Control Register	15-3
FR03	FP Dot Clock Source Register	15-3
FR04	Panel Power Sequencing Delay Register	15-4

FR05	Power Down Control 1 Register	15-5
FR06	FP Power Down Control Register	15-6
FR08	FP Pin Polarity Register	15-7
FR0A	Programmable Output Drive Register	15-8
FR0B	FP Pin Control 1 Register	15-9
FR0C	Pin Control 2 Register	15-10
FR0F	Activity Timer Control Register	15-11
FR10	FP Format 0 Register	15-12
FR11	FP Format 1 Register	15-14
FR12	FP Format 2 Register	15-16
FR13	FP Format 3 Register	15-18
FR16	FRC Option Select Register	15-19
FR17	Polynomial FRC Control Register	15-20
FR18	FP Text Mode Control Register	15-20
FR19	Blink Rate Control Register	15-21
FR1A	STN-DD Buffering Control Register	15-22
FR1E	M (ACDCLK) Control Register	15-22
FR1F	Diagnostic Register	15-23
FR20	FP Horizontal Panel Display Size LSB Register	15-24
FR21	FP Horizontal Sync Start LSB Register	15-24
FR22	FP Horizontal Sync End Register	15-25
FR23	FP Horizontal Total LSB Register	15-25
FR24	FP HSync (LP) Delay LSB Register	15-26
FR25	FP Horizontal Overflow 1 Register	15-26
FR26	FP Horizontal Overflow 2 Register	15-27
FR27	FP HSync (LP) Width and Disable Register	15-27
FR30	FP Vertical Panel Size LSB Register	15-28
FR31	FP Vertical Sync Start LSB (FR31) Register	15-28
FR32	FP Vertical Sync End Register	15-29
FR33	FP Vertical Total Register	15-29
FR34	FP VSync (FLM) Delay Register	15-30
FR35	FP Vertical Overflow 1 Register	15-30
FR36	FP Vertical Overflow 2 Register	15-31
FR37	FP VSync (FLM) Disable	15-31
FR40	Horizontal Compensation Register	15-32
FR41	Horizontal Stretching Register	15-34
FR48	Vertical Compensation Register	15-35
FR49-4C	Text Mode Vertical Stretching Register	15-36
FR4D	Vertical Line Replication Register	15-36
FR4E	Selective Vertical Stretching Disable Register	15-37
FR70	TMED Red Seed Register	15-38
FR71	TMED Green Seed Register	15-38
FR72	TMED Blue Seed Register	15-38
FR73	TMED Control Register	15-39
FR74	TMED2 Control Register	15-40

Chapter 16

Multimedia Registers

MR00	Module Capability Register	16-2
MR01	Secondary Capability Register	16-2
MR02	Capture Control 1 Register	16-3
MR03	Capture Control 2 Register	16-4
MR04	Capture Control 3 Register	16-5
MR05	Capture Control 4 Register	16-6
MR06	Capture Memory Address PTR1 Low Register	16-7

MR07	Capture Memory Address PTR1 Mid Register	16-7
MR08	Capture Memory Address PTR1 High Register	16-7
MR09	Capture Memory Address PTR2 Low Register	16-8
MR0A	Capture Memory Address PTR2 Mid Register	16-8
MR0B	Capture Memory Address PTR2 High Register	16-8
MR0C	Capture Line Memory Storage Width Register	16-9
MR0E	Capture Window X-LEFT Low Register	16-9
MR0F	Capture Window X-LEFT High Register	16-9
MR10	Capture Window X-RIGHT Low Register	16-10
MR11	Capture Window X-RIGHT High Register	16-10
MR12	Capture Window Y-TOP Low Register	16-11
MR13	Capture Window Y-TOP High Register	16-11
MR14	Capture Window Y-BOTTOM Low Register	16-12
MR15	Capture Window Y-BOTTOM High Register	16-12
MR16	H-SCALE Register	16-13
MR17	V-SCALE Register	16-13
MR18	Capture Frame/Field Count Register	16-13
MR1E	Playback Control 1 Register	16-14
MR1F	Playback Control 2 Register	16-15
MR20	Playback Control 3 Register	16-16
MR21	Double Buffer Status Register	16-17
MR22	Playback Memory Address PTR1 Low Register	16-18
MR23	Playback Memory Address PTR1 Mid Register	16-18
MR24	Playback Memory Address PTR1 High Register	16-18
MR25	Playback Memory Address PTR2 Low Register	16-19
MR26	Playback Memory Address PTR2 Mid Register	16-19
MR27	Playback Memory Address PTR2 High Register	16-19
MR28	Playback Line Memory Fetch Width Register	16-20
MR2A	Playback Window X-LEFT Low Register	16-20
MR2B	Playback Window X-LEFT High Register	16-20
MR2C	Playback Window X-RIGHT Low Register	16-21
MR2D	Playback Window X-RIGHT High Register	16-21
MR2E	Playback Window Y-TOP Low Register	16-22
MR2F	Playback Window Y-TOP High Register	16-22
MR30	Playback Window Y-BOTTOM Low Register	16-23
MR31	Playback Window Y-BOTTOM High Register	16-23
MR32	H-ZOOM Register	16-24
MR33	V-ZOOM Register	16-24
MR34	Playback Line Display Width Register	16-25
MR3C	Color Key Control 1 Register	16-25
MR3D-3F	Color Key Registers	16-26
MR40-42	Color Key Mask Registers	16-26
MR43	Line Count Low Register	16-27
MR44	Line Count High Register	16-27

Chapter 17

BitBLT Registers

BR00	Source and Destination Span Register	17-2
BR01	Pattern/Source Expansion Background Color & Transparency Key Register	17-3
BR02	Pattern/Source Expansion Foreground Color Register	17-4
BR03	Monochrome Source Control Register	17-5
BR04	BitBLT Control Register	17-7
BR05	Pattern Address Register	17-12
BR06	Source Address Register	17-13
BR07	Destination Address Register	17-14
BR08	Destination Width & Height Register	17-15

BR09	Source Expansion Background Color & Transparency Key Register	17-16
BR0A	Source Expansion Foreground Color Register	17-17

Chapter 18

Memory-Mapped Wide Extension Registers

ER00	Central Interrupt Control Register	18-2
ER01	Central Interrupt Status/Acknowledge Register	18-3
ER03	Miscellaneous Function Register	18-4

Appendix A

Display Modes	A-1
CRT-Only Display Modes	A-2
Standard VGA CRT-Only Display Modes	A-2
Chips Extended VGA CRT-Only Display Modes.....	A-3
Display Modes.....	A-6
Flat Panel-Only and Simultaneous 640x480 (VGA) Display Modes	A-6
Flat Panel-Only and Simultaneous 800x600 (SVGA) Display Modes.....	A-7
Flat Panel-Only and Simultaneous 1024x768 Display Modes	A-8
Flat Panel-Only and Simultaneous 1280x1024 Display Modes	A-9

Appendix B

Clock Generation	B-1
Clock Synthesizer	B-1
Dot Clock (DCLK)	B-1
Memory Clock (MCLK)	B-1
PLL Parameters	B-2
Programming the Clock Synthesizer.....	B-3
DCLK Programming.....	B-3
MCLK Programming.....	B-3
Programming Constraints	B-4
Programming Example	B-4
PCB Layout Considerations	B-5
Display Memory Bandwidth	B-7
STN-DD Panel Buffering	B-8
Horizontal and Vertical Clocking	B-9

Appendix C

Panel Power Sequencing	C-1
-------------------------------------	-----

Appendix D

Hardware Cursor and Pop Up Window	D-1
Basic Cursor Configuration	D-1
Base Address for Cursor Data	D-2
Cursor Vertical Extension	D-2
Cursor Colors	D-2
Cursor Positioning	D-3
Cursor Modes	D-3
32x32x2bpp & 64x64x2bpp AND/XOR Pixel Plane Modes	D-4
64x64x2bpp 4-Color Mode	D-6
64x64x2bpp 3-Color and Transparency Mode	D-7
128x128x1bpp 2-Color Mode	D-8
128x128x1bpp 1-Color and Transparency Mode	D-9

Appendix E

BitBLT Operation	E-1
Introduction	E-1
Color Depth Configuration and Color Expansion	E-2
Graphics Data Size Limitations	E-3
Bit-Wise Operations	E-3
Per-Pixel Write-Masking Operations	E-7
When the Source and Destination Locations Overlap	E-8
Contiguous vs. Discontiguous Graphics Data	E-12
Source Data	E-13
Monochrome Source Data	E-14
Pattern Data	E-14
Destination Data	E-17
BitBLT Programming Examples Pattern Fill -- A Very Simple BitBLT	E-18
Drawing Characters Using a Font Stored in System Memory	E-20

List Of Figures

Figure 1-1: Pixel Averaging Circuit	1-2
Figure 1-2: Pixel Averaging Method.....	1-3
Figure 1-3: Data Pipeline After MMUX, 2 Clocking	1-4
Figure 2-1: Pin Diagram, Top View	2-1
Figure 2-2: Pin Diagram, Bottom View.....	2-2
Figure 3-1: AC Test Timing	3-3
Figure 3-2: Reference Clock Timing	3-4
Figure 3-3: Reset Timing	3-5
Figure 3-4: PCI Bus Frame Timing	3-6
Figure 3-5: PCI Bus Stop Timing	3-7
Figure 3-6: PCI BIOS ROM Timing	3-8
Figure 3-7: Video Data Port Timing	3-9
Figure 3-8: Panel Output Timing	3-10
Figure 4-1: 256+16-Contact Ball Grid Array	4-1
Figure B-1: PLL Elements.....	B-1
Figure E-1: Block Diagram and Data Paths of the BitBLT Engine	E-1
Figure E-2: Block Diagram and Data Paths of the BitBLT Engine	E-7
Figure E-3: Source Corruption in BitBLT with Overlapping Source and Destination	E-8
Figure E-4: Correctly Performed BitBLT with Overlapping Source and Destination	E-10
Figure E-5: Suggested Starting Points for Source and Destination Overlap Situations	E-11
Figure E-6: On-Screen Single 6-Pixel Line in the Frame Buffer	E-12
Figure E-7: On-Screen 6x4 Array of Pixels in the Frame Buffer	E-13
Figure E- 8: Pattern Data	E-15
Figure E-9: Monochrome Pattern Data -- Occupies a Single Quadword	E-15
Figure E-10: 8bpp Pattern Data -- Occupies 64 Bytes (8 Quadwords)	E-15
Figure E-11: 16bpp Pattern Data -- Occupies 128 Bytes (16 Quadwords)	E-16
Figure E-12: 24bpp Pattern Data -- Occupies 256 Bytes (32 Quadwords)	E-16
Figure E-13: On-Screen Destination for Example Pattern Fill BitBLT	E-18
Figure E-14: Pattern Data for Example Pattern Fill BitBLT	E-19
Figure E-15: Results of Example Pattern Fill BitBLT	E-20
Figure E-16: On-Screen Destination for Example Character Drawing BitBLT	E-21
Figure E- 17: Source Data in System Memory for Example Character Drawing BitBLT	E-21
Figure E-18: Results of Example Character Drawing BitBLT	E-23

List of Tables

Table 1-1: 69000 Mode Support	1-5
Table 3-1: Absolute Maximum Conditions	3-1
Table 3-2: Normal Operating Conditions	3-1
Table 3-3: DAC Characteristics	3-1
Table 3-4: DC Characteristics:	3-2
Table 3-5: DC Drive Characteristics	3-2
Table 3-6: AC Test Conditions:	3-3
Table 3-7: AC Timing Characteristics - Reference Clock	3-4
Table 3-8: AC Timing Characteristics - Clock Generator	3-4
Table 3-9: AC Timing Characteristics - Reset	3-5
Table 3-10: AC Timing Characteristics - PCI Bus Frame (CLK=33MHz)	3-6
Table 3-11: AC Timing Characteristics - PCI Bus Stop (CLK=33MHz)	3-7
Table 3-12: AC Timing Characteristics - PC BIOS ROM	3-8
Table 3-13: AC Timing Characteristics - Video Input Port	3-9
Table 3-14: AC Timing Characteristics - Panel Output Timing	3-10
Table 6-1: PCI Configuration Registers	6-1
Table 6-2: General Control & Status Registers	6-1
Table 6-3: CRT Controller Registers	6-2
Table 6-4: Sequencer Registers	6-3
Table 6-5: Graphics Controller Registers	6-3
Table 6-6: Attribute Controller Register	6-3
Table 6-7: Palette DAC Registers	6-3
Table 6-8: Extension Register	6-4
Table 6-9: Flat Panel Registers	6-6
Table 6-10: Multimedia Registers	6-7
Table 6-11: BitBLT Registers	6-8
Table 6-12: Memory Mapped Wide Extension Registers	6-8
Table 7-1 PCI Configuration Registers	7-1
Table 15-1: Flat Panel Registers	15-1
Table 16-1: Multimedia Registers	16-1
Table 16-2: Color Key Bit Assignments	16-26
Table A-1: Standard VGA CRT-Only Display Modes	A-2
Table A-2: Extended VGA CRT-Only Display Modes	A-3
Table A-3: Flat Panel-Only and Simultaneous 640x480 (VGA) Display Modes.....	A-6
Table A-4: Flat Panel-Only and Simultaneous Display Modes for 800x600 Panels	A-7
Table A-5: Flat Panel-Only and Simultaneous Display Modes for 1024x768 Flat Panels	A-8
Table A-6: Flat Panel-Only and Simultaneous Display Modes for 1280x1024 Flat Panel	A-9
Table D-1: Memory Organization 32x32x2bpp AND/XOR Pixel Plane Mode	D-4
Table D-2: Memory Organization 64x64x2bpp AND/XOR Pixel Plane Mode	D-5
Table D-3: Pixel Data 32x32x2bpp and 64x64x2bpp AND/XOR Pixel Plane Modes	D-5
Table D-4: Memory Organization 64x64x2bpp 4-Color Mode	D-6
Table D-5: Pixel Data 64x64x2bpp 4-Color Mode	D-6
Table D-6: Memory Organization 64x64x2bpp 3-Color & Transparency Mode	D-7
Table D-7: Pixel Data 64x64x2bpp 3-Color & Transparency Mode	D-7
Table D-8: Memory Organization 128x128x1bpp 2-Color Mode	D-8
Table D-9: Pixel Data 128x128x1bpp 2-Color Mode	D-8
Table D-10: Memory Organization 128x128x1bpp 1-Color & Transparency Mode	D-9
Table D-11: Pixel Bit Definitions 128x128x1bpp 1-Color & Transparency Mode	D-9
Table E-1: Bit-Wise Operations and 8-bit Codes (00 - 5F)	E-4
Table E-2: Bit-Wise Operations and 8-bit Codes (60 - BF)	E-5
Table E-3: Bit-Wise Operations and 8-bit Codes (C0 - FF)	E-6

Chapter 1

Introduction / Overview

The 69000 is the first product in the CHIPS family of portable graphics accelerator product line that integrates high performance memory technology for the graphics frame buffer. Based on the proven HiQVideo™ graphics accelerator core, the 69000 combines state-of-the-art flat panel controller capabilities with low power, high performance integrated memory. The result is the start of a high performance, low power, highly integrated solution for the premier family of portable graphics products.

High Performance Integrated Memory

The 69000 is the first member of the HiQVideo™ family to provide integrated high performance synchronous DRAM (SDRAM) memory technology. Targeted at the mainstream notebook market, the 69000 incorporates 2MB of proprietary integrated SDRAM for the graphics/video frame buffer. The integrated SDRAM memory can support up to 83MHz operation, thus increasing the available memory bandwidth for the graphics subsystem. The result is support for additional high color / high resolution graphics modes combined with real-time video acceleration. This additional bandwidth also allows more flexibility in the other graphics functions intensely used in Graphical User Interfaces (GUIs) such as Microsoft™ Windows™.

HiQColor™ Technology

The 69000 integrates CHIPS breakthrough HiQColor™ technology. Based on the CHIPS proprietary TMED™ (Temporal Modulated Energy Distribution) algorithm, HiQColor technology is a unique process that allows the display of 16.7 million true colors on STN panels without using Frame Rate Control (FRC) or dithering. In addition, TMED also reduces the need for the panel tuning associated with current FRC-based algorithms. Independent of panel response, the TMED algorithm eliminates all of the flaws (such as shimmer, Mach banding, and other motion artifacts) normally associated with dithering and FRC. Combined with the new fast response, high-contrast, and low-crosstalk technology found in new STN panels, HiQColor technology enables the best display quality and color fidelity previously only available with TFT technology.

Versatile Panel Support

The HiQVideo™ family supports a wide variety of monochrome and color Single-Panel, Single-Drive (SS) and Dual-Panel, Dual Drive (DD), standard and high-resolution, passive STN and active matrix TFT/MIM LCD, and EL panels. With HiQColor™ technology, up to 256 gray scales are supported on passive STN LCDs. Up to 16.7M different colors can be displayed on passive STN LCDs and up to 16.7M colors on 24-bit active matrix LCDs.

The 69000 offers a variety of programmable features to optimize display quality. Vertical centering and stretching are provided for handling modes with less than 480 lines on 480-line panels. Horizontal and vertical stretching capabilities are also available for both text and graphics modes for optimal display of VGA text and graphics modes on 800x600, 1024x768 and 1280x1024 panels.

Acceleration for All Panels and All Modes

The 69000 graphics engine is designed to support high performance graphics and video acceleration for all supported display resolutions, display types, and color modes. There is no compromise in performance operating in 8, 16, or 24 bpp color modes allowing true acceleration while displaying up to 16.7M colors.

Television NTSC/PAL Flicker Free Output

The 69000 uses a flicker reduction process which makes text of all fonts and sizes readable by reducing the flicker and jumping lines on the display. To accomplish this, the 69000 uses a line buffer and digital filters to average adjacent vertical lines for odd/even display. The chip also uses both horizontal and vertical interpolation to make both graphics and text appear "smooth" on the television. This process reduces the effect of flicker in the NTSC mode.

Flicker reduction can be accomplished by averaging the contents of successive horizontal and vertical lines. See Figure 1-1. The flicker reduction circuit is in pixel data path, with the vertical averaging circuit followed by the horizontal averaging circuit. Both have bypass controls (Vertical filter enable and Horizontal filter enable). This flicker averaging circuit is placed before the DAC and before the flat panel pick off. The flat panel pins can be used for test verification of correct filter operation.

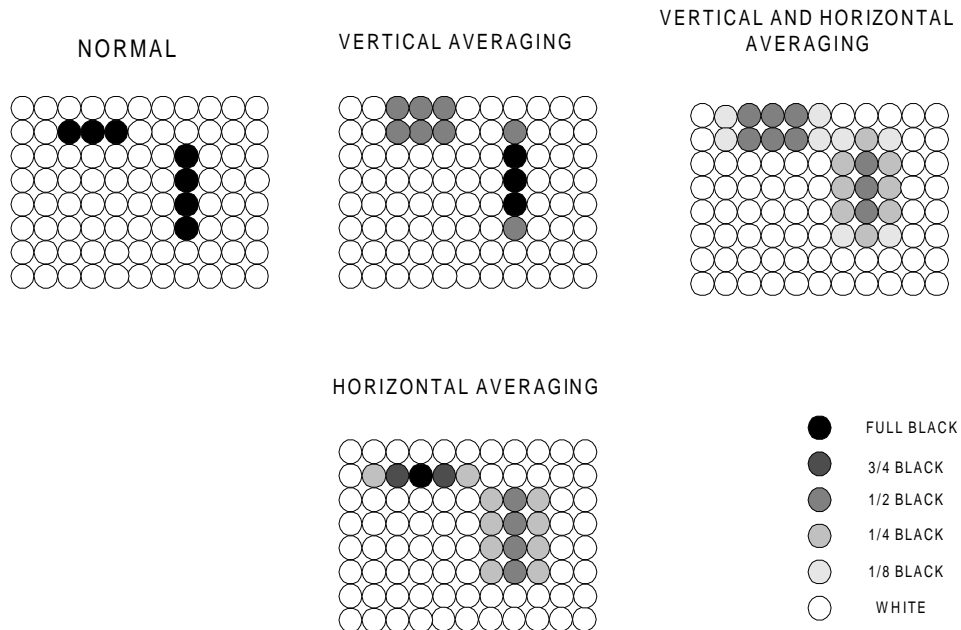

Figure 1-1: Pixel Averaging Circuit

For the non-flicker reduction mode, the display line data is stored sequentially in the FIFO buffer. For the flicker reduction mode the FIFO buffer data is written in strips of *segments* because the vertical filter averages the current and next line pixels. Each segment is written to alternate locations in the FIFO buffer. See Fig. 1-2.

The write pointer is modified to skip through the FIFO buffer. A current/next line flag is carried through the display pipeline to keep track of which line the pixel comes from. This is needed for the color key logic and the vertical filter averaging circuitry to align to the correct segment of pixels. The MMUX color key is formed on the "current" pixel pair.

Flicker reduced NTSC is supported in the following extended graphics modes:

NTSC:	640x480, 60 Hz Interlaced
PAL:	800x600, 50 Hz, Interlaced
Color Depths:	8 bit indexed
	15 bit RGB
	16 bit RGB
	24 bit RGB

MEMORY FETCH ORDERING - INTERLACING DISPLAY

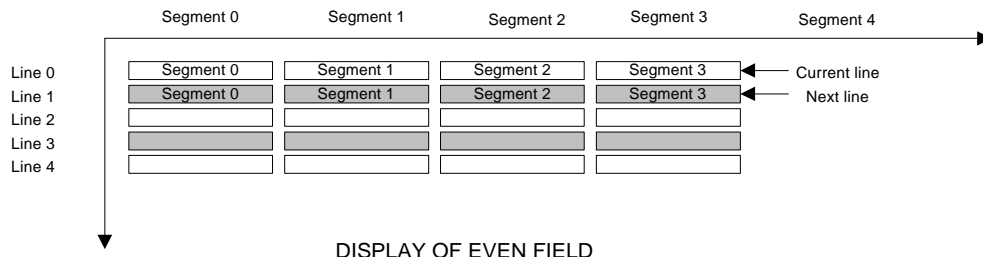

DISPLAY OF EVEN FIELD

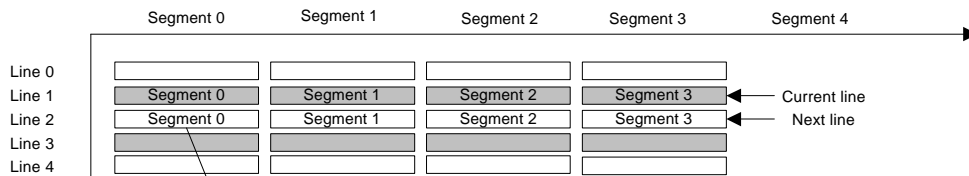

DISPLAY OF ODD FIELD

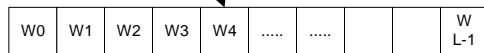

W = MEMORY WORD L = SEGMENT LENGTH

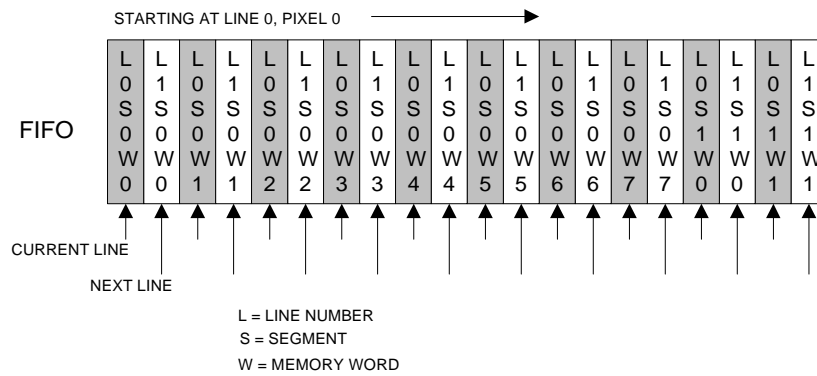

FIFO CONTENTS IN FLICKER REDUCTION MODE

Figure 1-2: Pixel Averaging Method

Memory words are converted to pixels by the *pixel packer*. See Figure 1-3 for pixel pipeline data format.

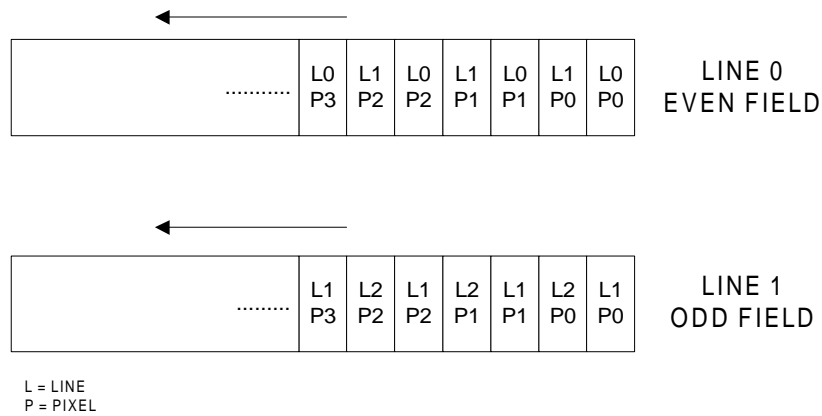

DATA PIPELINE AFTER MMUX, 2X CLOCKING

Figure 1-3: Data Pipeline After MMUX, 2 Clocking

The television output circuitry supports both NTSC and PAL standard formats, and scales images appropriately for both television formats and panels. The 69000 can drive these formats simultaneously, allowing a dual display capability.

HiQVideo™ Multimedia Support

The 69000 uses independent multimedia capture and display systems on-chip. The capture system places data in display memory (usually off screen) and the display system places the data in a window on the screen.

The capture system can receive data from either the system bus or from the ZV enabled video port in either RGB or YUV format. The input data can also be scaled down before storage in display memory. Capture of input data may also be double buffered for smoothing and to prevent image tearing. To better support MPEG2 (DVD) video decompression, the 69000 includes a line buffer to directly support the native format of MPEG2 data of 720 pixels wide.

The capture engine also supports image mirroring and rotation for camera support. This feature is important for applications such as video teleconferencing because it allows the image movements to appear on the display as it actually occurs. The image and movement is not a mirror image of what is actually taking place. The display system can independently place either RGB or YUV data from anywhere in display memory into an on-screen window which can be any size and located at any pixel boundary (YUV data is converted to RGB "on-the-fly" on output). This is important for the 69000 since the video must be stored in the integrated 2MB frame buffer and thus optimized to require very little space. Storing data in the native YUV format uses less memory for video while providing excellent playback display quality.

Non-rectangular windows are supported via color keying. The data can be fractionally zoomed on output up to 8x to fit the on-screen window and can be horizontally and vertically interpolated. Interlaced and non-interlaced data are both supported in the capture and display systems.

Low Power Consumption

The 69000 uses a variety of advanced power management features to reduce power consumption of the display sub-system and to extend battery life. Optimized for 3.3V operation, the 69000 internal logic, bus and panel interfaces operate at 3.3V but can tolerate 5V operation. For additional power savings, the integrated memory subsystem voltage is stepped-down internally to operate at 2.5V.

Software Compatibility / Flexibility

The HiQVideo controllers are fully compatible with the VGA standard at both the register and BIOS levels. CHIPS and third-party vendors supply a fully VGA compatible BIOS, end-user utilities and drivers for common application programs.

Display Modes Supported

The 69000 supports the modes which appear in the table below.

Table 1-1: 69000 Mode Support

Resolution	Color (bpp)	Refresh Rates (Hz)
640x480	8	60, 75, 85
640x480	16	60, 75, 85
640x480	24	60, 75, 85
800x600	8	60, 75, 85
800x600	16	60, 75, 85
800x600	24	60, 75, 85
1024x768	8	60, 75, 85
1024x768	16	60, 75, 85
1280x1024	8	60

Chapter 2

Pin Descriptions

Pin Diagram, Top View

	A	B	C	D	E	F	G	H	J	K	L	M	N	P	R	T	U	V	W	Y		
20	CFG4	CFG2	N/C	N/C	N/C	N/C	N/C	N/C	N/C	N/C	RMA17	N/C	N/C	N/C	N/C	N/C	VP1	VP6	VP10	RSVD	20	
19	CFG6	CFG5	CFG1	N/C	N/C	N/C	N/C	N/C	N/C	N/C	RMA16	N/C	N/C	N/C	N/C	N/C	VP2	VP5	VP9	VP11	VP14	19
18	N/C	CFG7	CFG3	CFG0	N/C	N/C	N/C	N/C	N/C	N/C	N/C	N/C	N/C	N/C	N/C	VP0	VP4	VP8	VP13	VP15	VCLK	18
17	RMA2	N/C	CFG8	TMD0	N/C	N/C	MEMGND	MEMVCC	N/C	N/C	N/C	N/C	MEMVCC	MEMGND	VP3	VP7	VP12	PCLK	HREF	P33	17	
16	RMA4	RMA1	N/C	CFG9													GPIO4	VREF	P34	P31	16	
15	RMA7	RMA5	RMA3	RMA0													P35	P32	P30	P28	15	
14	RMA10	RMA8	RMA6	MEMGND													GND	P29	P27	P25	14	
13	RMA14	RMA11	RMA9	MEMVCC													IOVCC	P26	P24	P21	13	
12	TMD1	RMA15	RMA13	RMA12													P23	P22	CORVCC	P20	12	
11	N/C	N/C	N/C	N/C													P16	P19	P18	P17	11	
10	N/C	CFG10	CFG11	N/C													P15	P12	P13	P14	10	
9	CFG12	CFG13	CFG15	CORVCC													P7	P8	P10	P11	9	
8	CFG14	RMD0	RMD2	RSVD													IOVCC	P4	P6	P9	8	
7	RMD1	RMD3	RMD5	GND													GND	P1	P3	P5	7	
6	RMD4	RMD6	ROMOE#	GPIO7													ENABKL	M	P0	P2	6	
5	RMD7	RSVD	RSVD	DCKVCC													DACVCC	ENAVDD	FLM	SHFCLK	5	
4	INT#	DCKGND	DCKVCC	RSVD	STNDBY	AD30	GND	IOVCC	AD20	TRDY#	DEVSEL	AD13	IOVCC	GND	AD2	GPIO1	DDC CLK	GRN	ENAVEE	LP	4	
3	DCKGND	MCKVCC	REFCLK	RSVD	AD31	AD27	AD24	AD23	AD19	C/BE2#	SERR#	AD14	AD10	C/BE0#	AD5	AD1	HSYNC	DDC DATA	BLUE	RED	3	
2	MCKGND	DCLKIN	RSVD	BUSCLK	AD29	AD25	IDSEL	AD21	AD17	FRAME#	PERR#	C/BE1	AD12	AD9	AD7	AD3	AD0	VSYN	RSET	DACGND	2	
1	RSVD	MCLKIN	RESET#	AD28	AD26	C/BE#	AD22	AD18	AD16	IRDY#	STOP#	PAR	AD15	AD11	AD8	AD6	AD4	GPIO0	IOVCC	RGND	1	
	A	B	C	D	E	F	G	H	J	K	L	M	N	P	R	T	U	V	W	Y		

12	GND	GND	GND	RGND
11	GND	GND	GND	RGND
10	GND	GND	GND	RGND
9	GND	GND	GND	RGND
	J	K	L	M

Figure 2-1: Pin Diagram

Pin Diagram, Bottom View

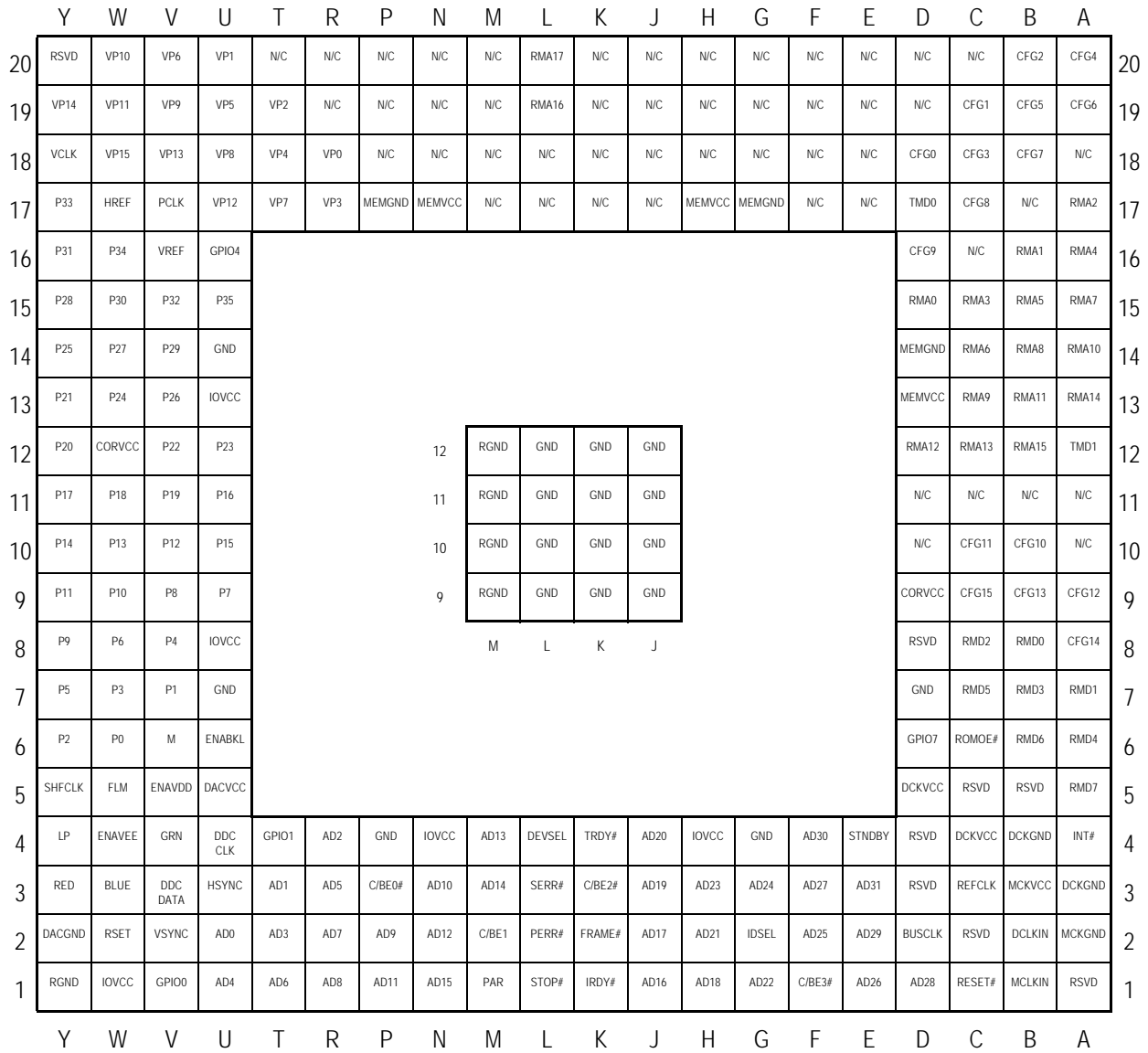

Figure 2-2: Pin Diagram

PCI Bus Interface

Ball	Pin Name	Type	Active	Powered	Description
C1	RESET#	In	Low	IOVCC & GND	Reset. This input sets all signals and registers in the chip to a known state. All outputs from the chip are tri-stated or driven to an inactive state. This pin is ignored during Standby mode (STNDBY# pin low). The remainder of the system (therefore the system bus) may be powered down if desired (all bus output pins are tri-stated in Standby mode).
D2	BUSCLK	In	High	IOVCC & GND	Bus Clock. This input provides the timing reference for all PCI bus transactions. All bus inputs except RESET# are sampled on the rising edge of BCLK. BCLK may be any frequency from DC to 33MHz.
M1	PAR	I/O	High	IOVCC & GND	Parity. This signal is used to maintain even parity across AD0-31 and C/BE0-3#. PAR is stable and valid one clock after the address phase. For data phases PAR is stable and valid one clock after either IRDY# is asserted on a write transaction or TRDY# is asserted on a read transaction. Once PAR is valid, it remains valid until one clock after the completion of the current data phase (i.e., PAR has the same timing as AD0-31 but delayed by one clock). The bus master drives PAR for address and write data phases; the target drives PAR for read data phases.
K2	FRAME#	In	Low	IOVCC & GND	Cycle Frame. Driven by the current master to indicate the beginning and duration of an access. Assertion indicates a bus transaction is beginning (while asserted, data transfers continue); de-assertion indicates the transaction is in the final data phase
K1	IRDY#	In	Low	IOVCC & GND	Initiator Ready. Indicates the bus master's ability to complete the current data phase of the transaction. During a write, IRDY# indicates valid data is present on AD0-31; during a read it indicates the master is prepared to accept data. A data phase is completed on any clock when both IRDY# and TRDY# are sampled then asserted (wait cycles are inserted until this occurs).
K4	TRDY#	S/TS	Low	IOVCC & GND	Target Ready. Indicates the target's ability to complete the current data phase of the transaction. During a read, TRDY# indicates that valid data is present on AD0-31; during a write it indicates the target is prepared to accept data. A data phase is completed on any clock when both IRDY# and TRDY# are sampled then asserted (wait cycles are inserted until this occurs).
L1	STOP#	S/TS	Low	IOVCC & GND	Stop. Indicates the current target is requesting the master to stop the current transaction.
L4	DEVSEL#	S/TS	Low	IOVCC & GND	Device Select. Indicates the current target has decoded its address as the target of the current access

Note: S/TS stands for "Sustained Tri-state". These signals are driven by only one device at a time, are driven high for one clock before released, and are not driven for at least one cycle after being released by the previous device. A pull-up provided by the bus controller is used to maintain an inactive level between transactions.

PCI Bus Interface (continued)

Ball	Pin Name	Type	Active	Powered	Description
L2	PERR#	S/TS	Low	IOVCC & GND	Parity Error. This signal reports data parity errors (except for Special Cycles where SERR# is used). The PERR# pin is Sustained Tri-state. The receiving agent will drive PERR# active two clocks after detecting a data parity error. PERR# will be driven high for one clock before being tri-stated as with all sustained tri-state signals. PERR# will not report status until the chip has claimed the access by asserting DEVSEL# and completing the data phase.
L3	SERR#	OD	Low	IOVCC & GND	System Error. Used to report system errors where the result will be catastrophic (address parity error, data parity errors for Special Cycle commands, etc.). This output is actively driven for a single PCI clock cycle synchronous to BCLK and meets the same setup and hold time requirements as all other bused signals. SERR# is not driven high by the chip after being asserted, but is pulled high only by a weak pull-up provided by the system. Thus, SERR# on the PCI bus may take two or three clock periods to fully return to an inactive state.
A4	INT#	OD	Low	IOVCC & GND	Interrupt request pin.

Note: S/TS stands for "Sustained Tri-state". These signals are driven by only one device at a time, are driven high for one clock before released, and are not driven for at least one cycle after being released by the previous device. A pull-up provided by the bus controller is used to maintain an inactive level between transactions.

PCI Bus Interface (continued)

Ball	Pin Name	Type	Active	Powered	Description
U2	AD0	I/O	High	IOVCC	PCI Address/Data Bus
T3	AD1	I/O	High	& GND	Address and data are multiplexed on the same pins. A bus transaction consists of an address phase followed by one or more data phases (both read and write bursts are allowed by the bus definition). The address phase is the clock cycle in which FRAME# is asserted (AD0-31 contain a 32-bit physical address). For I/O, the address is a byte address. For memory and configuration, the address is a DWORD address. During data phases AD0-7 contain the LSB and 24-31 contain the MSB. Write data is stable and valid when IRDY# is asserted; read data is stable and valid when TRDY# is asserted. Data transfers only during those clocks when both IRDY# and TRDY# are asserted.
R4	AD2	I/O	High		
T2	AD3	I/O	High		
U1	AD4	I/O	High		
R3	AD5	I/O	High		
T1	AD6	I/O	High		
R2	AD7	I/O	High		
R1	AD8	I/O	High		
P2	AD9	I/O	High		
N3	AD10	I/O	High		
P1	AD11	I/O	High		
N2	AD12	I/O	High		
M4	AD13	I/O	High		
M3	AD14	I/O	High		
N1	AD15	I/O	High		
					C/BE3-0 Command Type Supported
J1	AD16	I/O	High		0000 Interrupt Acknowledge
J2	AD17	I/O	High		0001 Special Cycle
H1	AD18	I/O	High		0010 I/O Read Y
J3	AD19	I/O	High		0011 I/O Write Y
J4	AD20	I/O	High		0100 -reserved-
H2	AD21	I/O	High		0101 -reserved-
G1	AD22	I/O	High		0110 Memory Read Y
H3	AD23	I/O	High		0111 Memory Write Y
G3	AD24	I/O	High		1000 -reserved-
F2	AD25	I/O	High		1001 -reserved-
E1	AD26	I/O	High		1010 Configuration Read Y
F3	AD27	I/O	High		1011 Configuration Write Y
D1	AD28	I/O	High		1100 Memory Read Multiple
E2	AD29	I/O	High		1101 Dual Address Cycle
F4	AD30	I/O	High		1110 Memory Read Line
E3	AD31	I/O	High		1111 Memory Read & Invalidate
P3	C/BE0#	In	Low	IOVCC	Bus Command/Byte Enables. During the address phase of a bus transaction, these pins define the bus command (see list above). During the data phase, these pins are byte enables that determine which byte lanes carry meaningful data: byte 0 corresponds to AD0-7, byte 1 to 8-15, byte 2 to 16-23, and byte 3 to 24-31.
M2	C/BE1#	In	Low	& GND	
K3	C/BE2#	In	Low		
F1	C/BE3#	In	Low		
G2	IDSEL	In	High	IOVCC & GND	Initialization Device Select. Used as a chip select during configuration read and write transactions

Configuration Pins and ROM Interface

Ball	Pin Name	Type	Active	Powered	Description
D18	CFG0	In	n/a	IOVCC	CFG0 through CFG15 are latched into registers XR70 and XR71 on reset for use as configuration inputs. Please see register descriptions for XR70 and XR71 for complete details on the configuration options.
C19	CFG1	In	n/a	& GND	
B20	CFG2	In	n/a		
C18	CFG3	In	n/a		
A20	CFG4	In	n/a		
B19	CFG5	In	n/a		
A19	CFG6	In	n/a		
B18	CFG7	In	n/a		
C17	CFG8	In	n/a		
D16	CFG9	In	n/a		
B10	CFG10	In	n/a		
C10	CFG11	In	n/a		
A9	CFG12	In	n/a		
B9	CFG13	In	n/a		
A8	CFG14	In	n/a		
C9	CFG15	In	n/a		
B8	RMD0	IN	High	IOVCC	RMD0 through RMD7 are used as BIOS ROM data inputs during system start-up (i.e., before the system enables the graphics controller memory interface).
A7	RMD1	IN	High	& GND	
C8	RMD2	IN	High		
B7	RMD3	IN	High		
A6	RMD4	IN	High		
C7	RMD5	IN	High		
B6	RMD6	IN	High		
A5	RMD7	IN	High		
C6	ROMOE# (MCLKOUT)	Out	Low	IOVCC & GND	BIOS ROM Output Enable. May be configured as MCLK output in test mode.
D15	RMA0	Out	n/a	IOVCC	These pins are BIOS ROM address outputs RMA0-17. BIOS ROMs are not normally required in portable computer designs (the graphics system BIOS code is normally included in the system BIOS ROM). However, the 69000 provides BIOS ROM interface capability for development systems and add-in card flat panel graphics controllers. Since the PCI Bus specifications require only one load on the bus for the entire graphics subsystem, the BIOS ROM interface is "through the chip".
B16	RMA1	Out	n/a	& GND	
A17	RMA2	Out	n/a		
C15	RMA3	Out	n/a		
A16	RMA4	Out	n/a		
B15	RMA5	Out	n/a		
C14	RMA6	Out	n/a		
A15	RMA7	Out	n/a		
B14	RMA8	Out	n/a		
C13	RMA9	Out	n/a		
A14	RMA10	Out	n/a		
B13	RMA11	Out	n/a		
D12	RMA12	Out	n/a		
C12	RMA13	Out	n/a		
A13	RMA14	Out	n/a		
B12	RMA15	Out	n/a		
L19	RMA16	Out	n/a		
L20	RMA17	Out	n/a		

Flat Panel Display Interface

Ball	Pin Name	Type	Active	Powered	Description
W6	P0	Out	High	IOVCC	Flat panel data bus of up to 36-bits.
V7	P1	Out	High	& GND	
Y6	P2	Out	High		
W7	P3	Out	High		
V8	P4	Out	High		
Y7	P5	Out	High		
W8	P6	Out	High		
U9	P7	Out	High		
V9	P8	Out	High		
Y8	P9	Out	High		
W9	P10	Out	High		
Y9	P11	Out	High		
V10	P12	Out	High		
W10	P13	Out	High		
Y10	P14	Out	High		
U10	P15	Out	High		
U11	P16	Out	High		
Y11	P17	Out	High		
W11	P18	Out	High		
V11	P19	Out	High		
Y12	P20	Out	High		
Y13	P21	Out	High		
V12	P22	Out	High		
U12	P23	Out	High		
W13	P24	Out	High		
Y14	P25	Out	High		
V13	P26	Out	High		
W14	P27	Out	High		
Y15	P28	Out	High		
V14	P29	Out	High		
W15	P30	Out	High		
Y16	P31	Out	High		
V15	P32	Out	High		
Y17	P33	Out	High		
W16	P34	Out	High		
U15	P35	Out	High		

Flat Panel Display Interface (continued)

Ball	Pin Name	Type	Active	Powered	Description
Y5	SHFCLK	OUT	High	IOVCC & GND	Shift Clock. Pixel clock for flat panel data.
W5	FLM	OUT	High	IOVCC & GND	First Line Marker. Flat Panel equivalent of VSYNC.
Y4	LP (CL1)(DE) (BLANK#)	OUT	High	IOVCC & GND	Latch Pulse. Flat Panel equivalent of HSYNC. May also be configured as Display Enable (DE) or BLANK#. Some panels use the signal name of CL1.
V6	M (DE) (BLANK#)	OUT	High	IOVCC & GND	M signal for panel AC drive control (may also be called ACDCLK). May also be configured as BLANK# or as Display Enable (DE) for TFT Panels.
V5	ENAVDD	I/O	High	IOVCC & GND	Power sequencing control for panel driver electronics voltage VDD.
W4	ENAVEE (ENABKL)	I/O	High		Power sequencing control for panel bias voltage VEE. May also be configured as ENABKL.
U6	ENABKL	I/O	High		Power sequencing control for enabling the backlight.

To accommodate a wide variety of panel types, the graphics controller has been designed to output its data in any of a number of formats. These formats include different data widths for the colors belonging to each pixel, and the ability to accommodate different pixel data transfer timing requirements.

For STN-DD panels, pins P0 through P35 are organized into groups corresponding to the upper and lower parts of the panel. The names of the signals for the upper and lower parts follow a naming convention of Uxx and Lxx, respectively.

For panels that require a pair of adjacent pixels be sent with every shift clock, pins P0 through P35 are organized into groups corresponding to the first and second (from right to left) pixels of each pair of pixels being sent. The names of the signals for the first and second pixels of each such pair follow a naming convention of Fxx and Sxx, respectively.

Panels that transfer data on both edges of SHFCLK are also supported. See the description for register FR12 for more details.

Flat Panel Display Interface (continued)

		Mono	Mono	Mono	Color	Color	Color	Color	Color	Color	Color	Color	Color
		SS	DD	DD	TFT	TFT	TFT	TFT-HR	STN-SS	STN-SS	STN-DD	STN-DD	STN-DD
Pin#	Pin Name	8-bit	8-bit	16 bit	9/12/16 bit	18/24 bit	36-bit	18/24 bit	8-bit (4bP)	16-bit (4bP)	8-bit (4bP)	16-bit (4bP)	24-bit
W6	P0	D0	UD3	UD7	B0	B0	FB0	FB0	R1	R1	UR1	UR0	UR0
V7	P1	D1	UD2	UD6	B1	B1	FB1	FB1	B1	G1	UG1	UG0	UG0
Y6	P2	D2	UD1	UD5	B2	B2	FB2	FB2	G2	B1	UB1	UB0	UB0
W7	P3	D3	UD0	UD4	B3	B3	FB3	FB3	R3	R2	UR2	UR1	LR0
V8	P4	D4	LD3	UD3	B4	B4	FB4	SB0	B3	G2	LR1	LR0	LG0
Y7	P5	D5	LD2	UD2	G0	B5	FB5	SB1	G4	B2	LG1	LG0	LB0
W8	P6	D6	LD1	UD1	G1	B6	SB0	SB2	R5	R3	LB1	LB0	UR1
U9	P7	D7	LD0	UD0	G2	B7	SB1	SB3	B5	G3	LR2	LR1	UG1
V9	P8			LD7	G3	G0	SB2	FG0		B3		UG1	UB1
Y8	P9			LD6	G4	G1	SB3	FG1		R4		UB1	LR1
W9	P10			LD5	G5	G2	SB4	FG2		G4		UR2	LG1
Y9	P11			LD4	R0	G3	SB5	FG3		B4		UG2	LB1
V10	P12			LD3	R1	G4	FG0	SG0		R5		LG1	UR2
W10	P13			LD2	R2	G5	FG1	SG1		G5		LB1	UG2
Y10	P14			LD1	R3	G6	FG2	SG2		B5		LR2	UB2
U10	P15			LD0	R4	G7	FG3	SG3		R6		LG2	LR2
U11	P16					R0	FG4	FR0					LG2
Y11	P17					R1	FG5	FR1					LB2
W11	P18					R2	SG0	FR2					UR3
V11	P19					R3	SG1	FR3					UG3
Y12	P20					R4	SG2	SR0					UB3
Y13	P21					R5	SG3	SR1					LR3
V12	P22					R6	SG4	SR2					LG3
U12	P23					R7	SG5	SR3					LB3
W13	P24							FR0					
Y14	P25							FR1					
V13	P26							FR2					
W14	P27							FR3					
Y15	P28							FR4					
V14	P29							FR5					
W15	P30							SR0					
Y16	P31							SR1					
V15	P32							SR2					
Y17	P33							SR3					
W16	P34							SR4					
U15	P35							SR5					
Y5	SHFCLK	SHFCLK	SHFCLK	SHFCLK	SHFCLK	SHFCLK	SHFCLK	SHFCLK	SHFCLK	SHFCLK	SHFCLK	SHFCLK	SHFCLK
Pixels/Clock:		8	8	16	1	1	2	2	2-2/3	5-1/3	2-2/3	5-1/3	8

See the notes for this table on the previous page.

CRT Interface

Ball	Pin Name	Type	Active	Powered	Description
U3	HSYNC (CSYNC)	Out	Both	IOVCC & GND	CRT Horizontal Sync (polarity is programmable) or "Composite Sync" for support of various external NTSC/PAL encoder chips.
V2	VSYNC	Out	Both	IOVCC & GND	CRT Vertical Sync (polarity is programmable).
Y3	RED	Out	Analog	DACVCC & DACGND	CRT analog video outputs from the internal color palette DAC. The DAC is designed for a 37.5Ω equivalent load on each pin (e.g. 75Ω resistor on the board, in parallel with the 75Ω CRT load)
V4	GREEN	Out	Analog		
W3	BLUE	Out	Analog		
W2	RSET	In	N/A	DACVCC & DACGND	Set point resistor for the internal color palette DAC. A 528Ω 1% resistor is required between RSET and DACGND.
V3	DDC DATA (GPIO2)	I/O	High	IOVCC & GND	General purpose I/O, suitable for use as DDC Data.
U4	DDC CLK (GPIO3)	I/O	High	IOVCC & GND	General purpose I/O, suitable for use as DDC Clock. These two pins are functionally suitable for a DDC interface between the graphics controller chip and a CRT monitor.

Video Interface

Ball	Pin Name	Type	Active	Powered	Description
V16	VREF	I/O	High	IOVCC & GND	Vertical Reference Input.
W17	HREF	In	High	IOVCC & GND	Horizontal Reference Input
Y18	VCLK	In	High	IOVCC & GND	Video Input Clock
V17	PCLK (VCLKOUT)	Out	High	IOVCC & GND	Video in port PCLK out. May also be configured as the VCLK output in test mode.
R18	VP0	In	High	IOVCC & GND	Video data port data bus. In ZV mode, VP0-7 correspond to Y0-7, and VP8-15 correspond to UV0-7.
U20	VP1	In	High		
T19	VP2	In	High		
R17	VP3	In	High		
T18	VP4	In	High		
U19	VP5	In	High		
V20	VP6	In	High		
T17	VP7	In	High		
U18	VP8	In	High		
V19	VP9	In	High		
W20	VP10	In	High		
W19	VP11	In	High		
U17	VP12	In	High		
V18	VP13	In	High		
Y19	VP14	In	High		
W18	VP15	In	High		

Miscellaneous

Ball	Pin Name	Type	Active	Powered	Description
E4	STNDBY#	In	Low	IOVCC & GND	Standby Control Pin. Pull this pin low to place the chip in Standby Mode. A low-to-high transition on the pin will cause change to exit standby mode, host standby mode, and panel off mode.
C3	REFCLK (MCLKIN)	In	High	IOVCC & GND	Reference Clock Input. This pin serves as the input for an external reference oscillator (usually 14.31818MHz). All internal timings are derived from this primary clock input source. Alternatively, this can be configured to be used as an input for an externally provided MCLK through a strapping option and register programming. During normal operation, an external MCLK should be provided through MCLKIN.
B2	DCLKIN	In	High	IOVCC & GND	Optional input for an externally provided DCLK. Enabled via strapping option and register programming. See the descriptions for registers XR70 and XRCF for complete details.
B1	MCLKIN	In	High	IOVCC & GND	Optional input for an externally provided MCLK. Enabled via strapping option and register programming. See the descriptions for registers XR70 and XRCF for complete details.
V1	GPIO0 (ACTI)	I/O	High	IOVCC & GND	General Purpose I/O pin #0. Can also be used as the ACTI output (Activity Indicator).
T4	GPIO1 (32KHz)	I/O	High	IOVCC & GND	General Purpose I/O pin #1. Can also be used as a 32KHz clock input for panel power sequencing.
U16	GPIO4	I/O	High	IOVCC & GND	General purpose I/O pin #4.
D6	GPIO7	I/O	High	IOVCC & GND	General purpose I/O pin #7.
D17 A12	TMD0 TMD1	n/a n/a	n/a n/a		These two pins are for internal use only and should be left open.

Power and Ground

Ball	Pin Name	Description	
U5	DACVCC	Analog power for the internal RAMDAC.	DACVCC should be isolated from all other VCCs, and should not be greater than CORVCC.
Y2	DACGND	Analog ground for the internal RAMDAC.	DACGND should be common with digital ground but must be tightly coupled to DACVCC.
B3 A2	MCKVCC MCKGND	Analog power and ground pins for the internal memory clock synthesizer (MCLK).	MCKVCC and DCKVCC must be at the same voltage level as CORVCC. Each of the MCKVCC/MCKGND and DCKVCC/DCKGND pairs must be INDIVIDUALLY decoupled.
C4 D5 A3 B4	DCKVCC DCKGND	Analog power and ground pins for the internal dot clock synthesizer (DCLK).	Balls D5 and C4 (DCKVCC) may be jumpered together. Balls B4 and A3 (DCKGND) may be jumpered together. Refer to the section on clock generation for suggested clock power and ground PCB layout.
D7 G4 P4 U14 U7 J9 J10 J11 J12 K9 K10 K11 K12 L9 L10 L11 L12	GND	Digital ground.	
D9 W12	CORVCC	Digital power for the graphics controller internal logic (a.k.a., the "core" VCC).	
D14 G17 P17	MEMGND	Embedded memory ground.	
M9 M10 M11 M12 Y1	RGND	Internal reference GND, should be tied to GND.	
H4 N4 U8 U13 W1	IOVCC	I/O Power.	
D13 H17 N17	MEMVCC	Power for embedded memory.	

Reserved and No Connect

Pin Name	Ball
Reserved	A1, B5, C2, C5, D3, D4, D8, Y20
No Connect	A10, A11, A18, B11, B17, C11, C16, C20, D10, D11, D19, D20, E17, E18, E19, E20, F17, F18, F19, F20, G18, G19, G20, H18, H19, H20, J17, J18, J19, J20, K17, K18, K19, K20, L17, L18, M17, M18, M19, M20, N18, N19, N20, P18, P19, P20, R19, R20, T20

Chapter 3

Electrical Specifications

Table 3-1: Absolute Maximum Conditions

Symbol	Parameter	Min	Max	Units
V_{CC}	Supply Voltage	-0.5	5.0	V
V_I	Input Voltage	-0.5	5.5	V
T_{STG}	Storage Temperature	-40	125	°C

Note: Permanent device damage may occur if Absolute Maximum Rating are exceeded. Operation must be restricted to the conditions under Normal Operating Conditions.

Table 3-2: Normal Operating Conditions

Symbol	Parameter	Min	Typical	Max	Units
V_{CC}	Supply Voltage	3.0	3.3	3.6	V
T_A	Ambient Temperature	0	—	70	°C

Table 3-3: DAC Characteristics

Symbol	Parameter	Notes	Min	Typical	Max	Units
I_O	Full Scale Output Current	$R_{SET}=560\Omega$ and 37.5Ω Load	—	18.6	—	mA
	Full Scale Error		—	—	± 5	%
	DAC to DAC Correlation		—	1.27	—	%
	DAC Linearity		± 2	—	—	LSB

Note: These values apply under normal operating conditions unless otherwise noted.

Table 3-4: DC Characteristics.

Symbol	Parameter	Notes	Min	Max	Units
P_D	Power Dissipation	All VCCs at 3.3V MCLK=83MHz, DCLK=110MHz	–	1.0	W
I_{IL}	Input Leakage Current		–100	+100	μ A
I_{OZ}	Output Leakage Current	High Impedance	–100	+100	μ A
V_{IL}	Input Low Voltage	All input pins	–0.5	0.8	V
V_{IH}	Input High Voltage	All input pins	$0.6 \times V_{CC}$	5.5	V
V_{OL}	Output Low Voltage	Under max load per table 16-5 (3.3V)	–	0.5	V
V_{OH}	Output High Voltage	Under max load per table 16-5 (3.3V)	$0.7 \times V_{CC}$	–	V

Notes: These values apply under normal operating conditions unless otherwise noted.
For power configuration data, please refer to an appropriate application note.

Table 3-5: DC Drive Characteristics

Symbol	Parameter	Output Pins	DC Test Conditions	Min	Units
I_{OL}	Output Low Current	H/VSYNC, P0-P35, SHFCLK, M	$V_{OUT} \leq V_{OL}$ and $V_{CC} = 3.3V$	12	mA
		DEVSEL#, PAR, PERR#, SERR#, STOP#, TRDY#		8	mA
		ACTI, AD0-AD31, ENABKL, ENAVDD, ENAVEE, FLM, LP		2	mA
I_{OH}	Output High Current	H/VSYNC, P0-P35, SHFCLK, M	$V_{OUT} \geq V_{OL}$ and $V_{CC} = 3.3V$	12	mA
		DEVSEL#, PAR, PERR#, SERR#, STOP#, TRDY#		8	mA
		ACTI, AD0-AD31, ENABKL, ENAVDD, ENAVEE, FLM, LP		2	mA
		All other outputs			

Note: These values apply under normal operating conditions unless otherwise noted.

Table 3-6: AC Test Conditions:

Symbol	Parameter	Minimum	Maximum	Units
V_{CC}	Supply Voltage	3.1	3.6	V
V_{TEST}	All AC parameters	$0.4 V_{CC}$	1.5	V
V_{IL}	Input low voltage (10% of V_{CC})	$0.1 V_{CC}$	$0.1 V_{CC}$	V
V_{IH}	Input high voltage (90% of V_{CC})	$V_{CC} - 0.1$	$V_{CC} - 0.1$	V
T_R	Maximum input rise time (3.3/5V)	3	3	ns
T_F	Maximum input fall time (3.3/5V)	2	2	ns

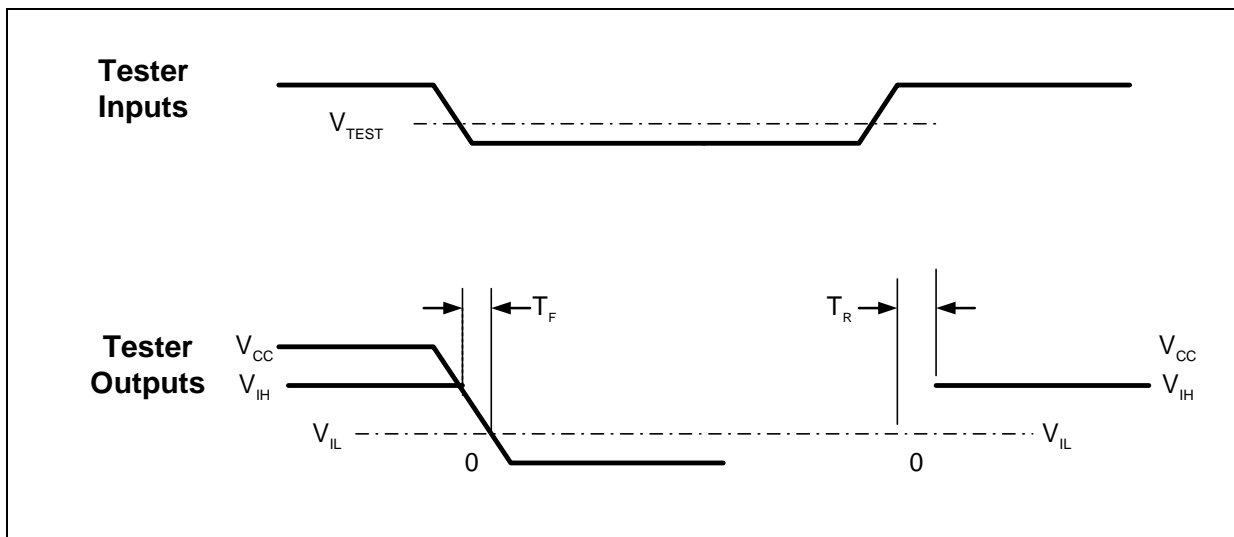
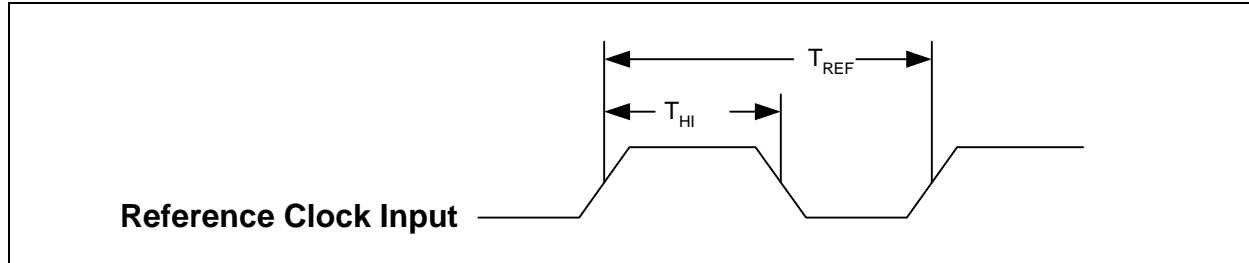

Figure 3-1: AC Test Timing

Table 3-7: AC Timing Characteristics - Reference Clock

Symbol	Parameter	Notes	Min	Typical	Max	Units
F_{REF}	Reference Frequency		1	14.31818	60	MHz
T_{REF}	Reference Clock Period		16.6	69.84128	1000	ns
T_{HI} / T_{REF}	Reference Clock Duty Cycle		40	–	60	%

**Figure 3-2: Reference Clock Timing****Table 3-8: AC Timing Characteristics - Clock Generator**

Symbol	Parameter	Notes	Min	Typical	Max	Units
F_{DCLK}	DCLK Frequency		–	–	135	MHz
F_{MCLK}	MCLK Frequency		–	–	83	MHz

Table 3-9: AC Timing Characteristics - Reset

Symbol	Parameter	Notes	Min	Max	Units
T_{IPR}	Reset Inactive from Power Stable	See Note 1	1	–	ms
T_{ORS}	Reset Inactive from Ext. Osc. Stable		0	–	ms
T_{RES}	Minimum Reset Pulse Width	See Note 2	1	–	ms
T_{STR}	Reset Inactive from Standby Inactive	RESET# is ignored in Standby Mode	2	–	ms
T_{RSR}	Reset Rise Time	measured 0.1V _{cc} to 0.9V _{cc}	–	20	ns
T_{RSO}	Reset Active to Output Float Delay		–	40	ns
T_{CSU}	Configuration Setup Time	See Note 3	20	–	ns
T_{CHD}	Configuration Hold Time		5	–	ns

Note 1: This parameter includes time for internal voltage stabilization of all sections of the chip, start-up and stabilization of the internal clock synthesizer, and setting of all internal logic to a known state.

Note 2: This parameter includes time for the internal clock synthesizer to reset to its default frequency and time to set all internal logic to a known state. It assumes power is stable and the internal clock synthesizer is already operating at some stable frequency.

Note 3: This parameter specifies the setup time to latch reliably the state of the configuration bits. Changes in some configuration bits may take longer to stabilize inside the chip (such as internal clock synthesizer-related bits 4 and 5). The recommended configuration bit setup time is T_{RES} to insure that the chip is in a completely stable state when Reset goes inactive.

**Figure 3-3: Reset Timing**

Table 3-11: AC Timing Characteristics - PCI Bus Stop (CLK=33MHz)

Symbol	Parameter	Notes	Min	Max	Units
T _{SZH}	STOP# High Z to High from CLK		2	11	ns
T _{SHL}	STOP# Active from CLK		2	11	ns
T _{SLH}	STOP# Inactive from CLK		2	11	ns
T _{SHZ}	STOP# High before High Z		1	–	CLK

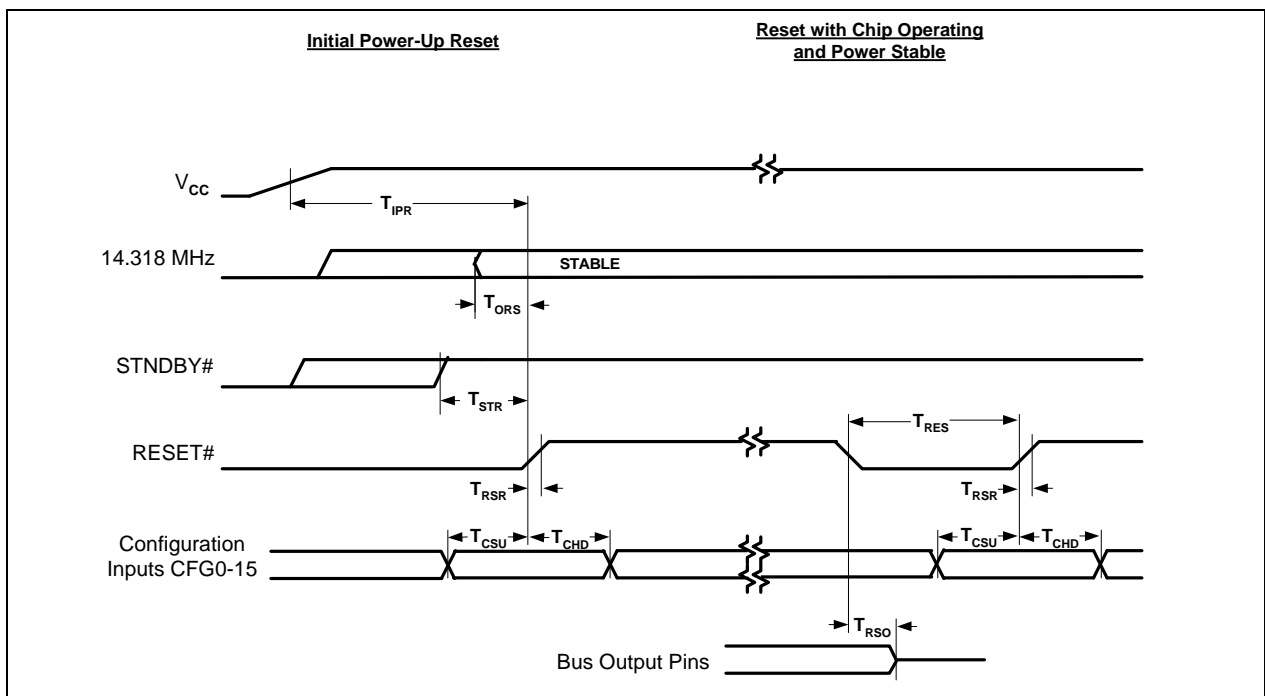
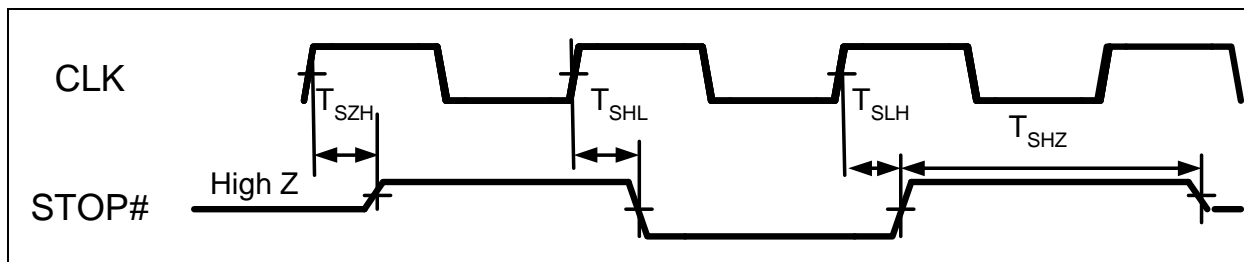

Figure 3-5: PCI Bus Stop Timing

Table 3-12: AC Timing Characteristics PC BIOS ROM

Symbol	Parameter	Notes	Min	Max	Units
T _{ROE}	ROMOE# Active from CLK		–	40	ns
T _{ROM}	Slowest Permissible BIOS ROM Access Speed		–	150	ns

Note: PCI BIOS ROM timing is derived from the PCI bus clock. Timing sequences are fixed assuming the use of widely-available, low-cost, typical industry-standard EPROMs. Timing specifications and performance of BIOS ROM memory accesses are non-critical since PCI BIOS ROM data is always shadowed into high-speed system memory prior to execution of BIOS code.

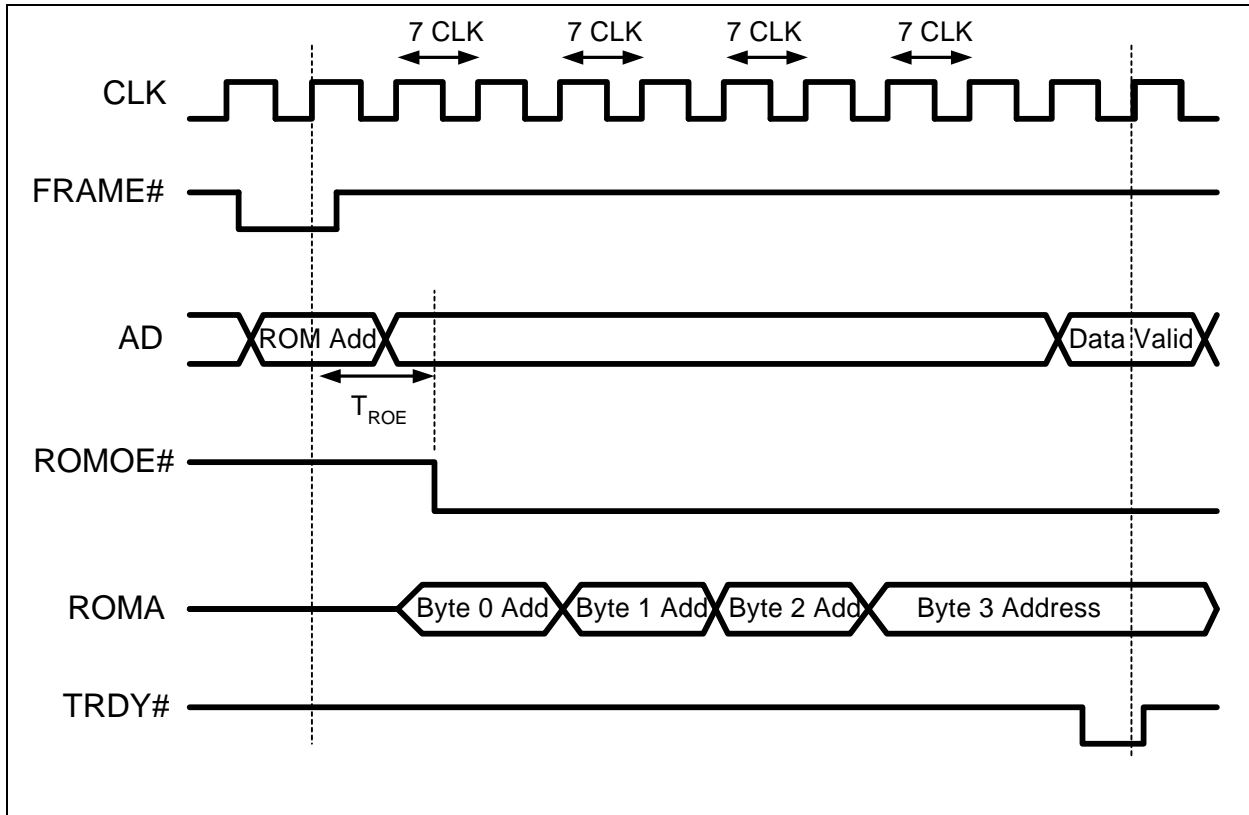

Figure 3-6: PCI BIOS ROM Timing

Table 3-13: AC Timing Characteristics - Video Data Port

Symbol	Parameter	Notes	Min	Max	Units
T_{VPS}	VP0 - VP15 (Incoming Data) Setup	In ZV-Port Mode	5	–	ns
T_{VPH}	VP0 - VP15 (Incoming Data) Hold		3	–	ns
T_{HRS}	HREF (Incoming HS) Setup		5	–	ns
T_{HRH}	HREF (Incoming HS) Hold		3	–	ns
T_{VRS}	VREF (Incoming VS) Setup		5	–	ns
T_{VRH}	VREF (Incoming VS) Hold		3	–	ns
F_{VCLK}	VCLK Frequency (T_{VCLK} is VCLK period)		10	33	MHz
	VCLK Duty Cycle		40	60	%

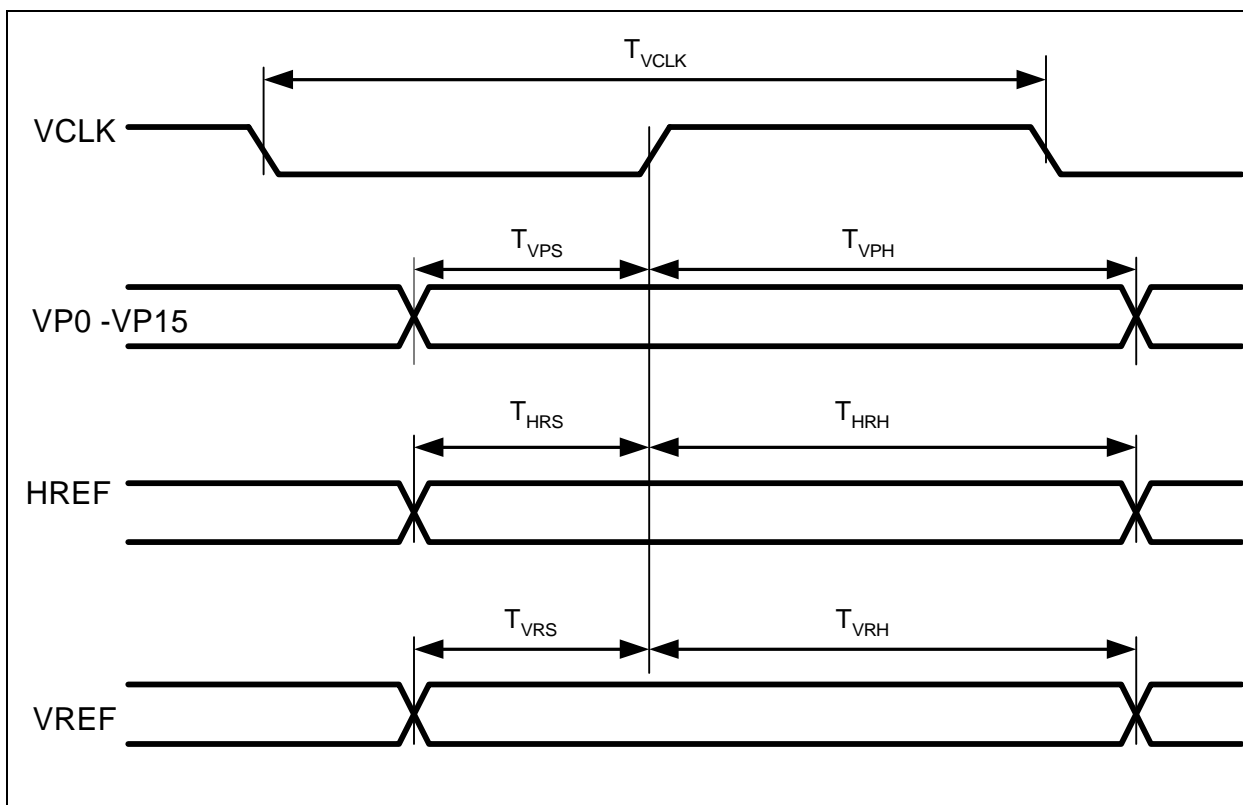

Figure 3-7: Video Data Port Timing

Table 3-14: AC Timing Characteristics - Panel Output Timing

Symbol	Parameter	Signaling	Min	Max	Units
T_{SCLK}	SHFCLK cycle time	Measured at $0.4V_{CC}$	15	–	ns
T_{DOVD}	DE and P[35..0] Output Valid Delay		-3	4	ns
T_{COVD}	LP and FLM Output Valid Delay		-3	3	ns
	SHFCLK Duty Cycle		40	60	%

Note: AC Timing is valid when max output loading=25pF.

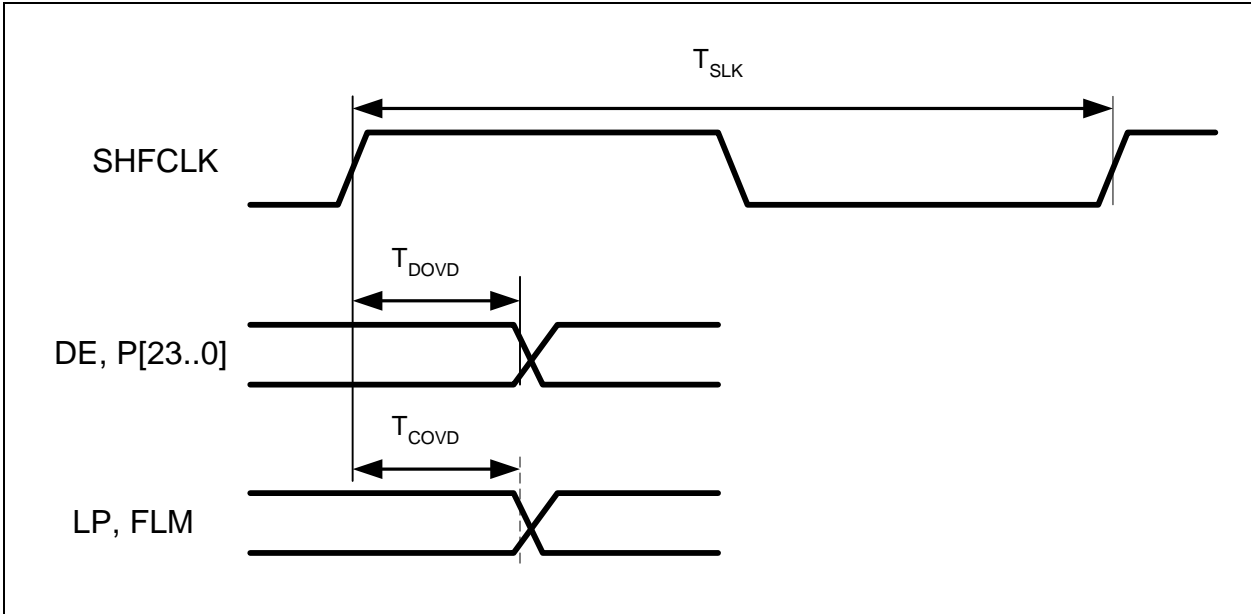
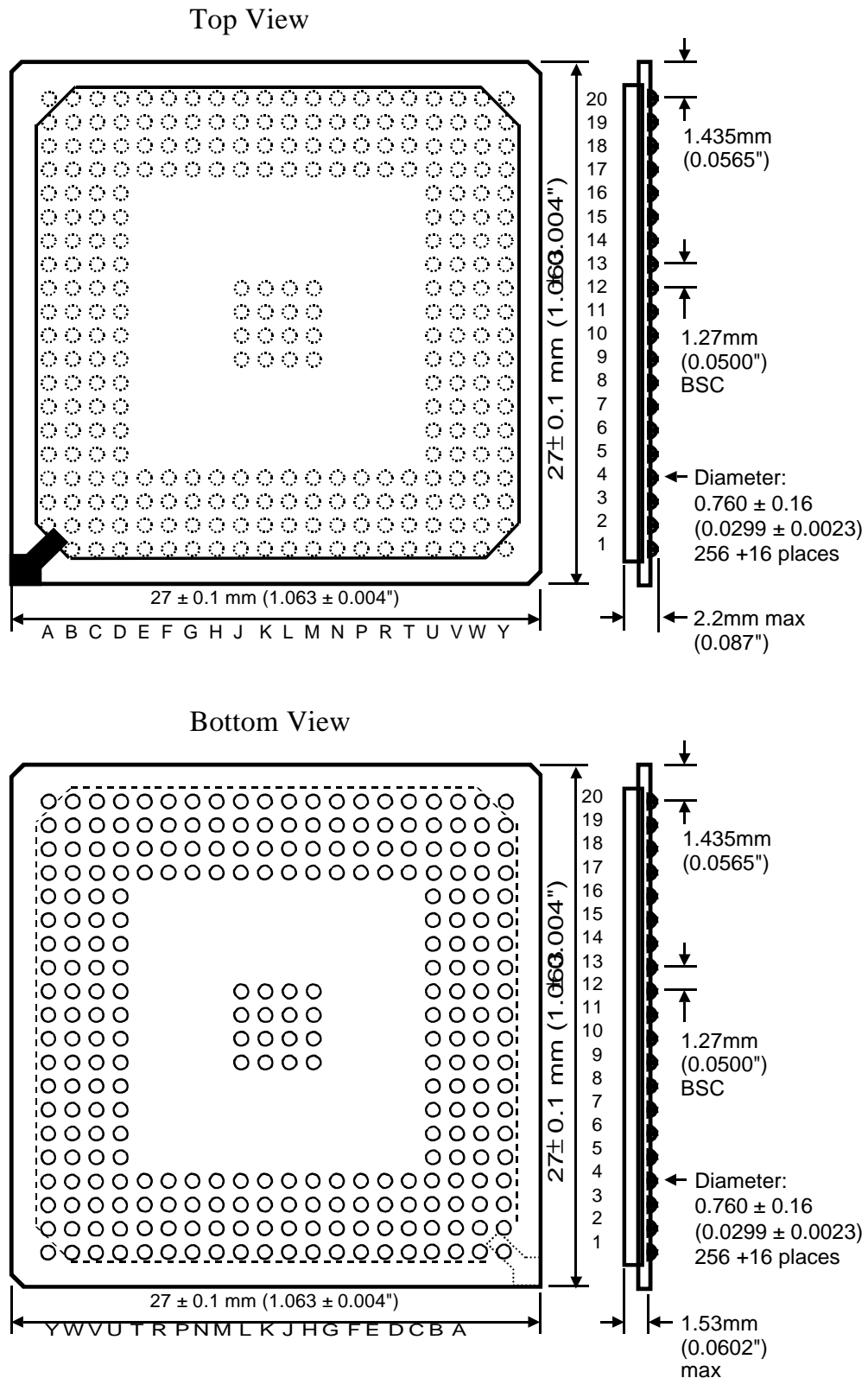

Figure 3-8: Panel Output Timing

Chapter 4

Mechanical Specifications



Chapter 5

I/O and Memory Address Maps

An extensive set of registers normally controls the graphics system. These registers are a combination of registers defined by IBM when the Video Graphics Array (VGA) was first introduced, and others that have been added to support graphics modes that have color depths, resolutions, and hardware acceleration features that go well beyond the original VGA standard. This chapter provides an overview of the address locations and sub-addressing mechanisms used to access the various registers and the frame buffer of this graphics controller.

Some of the registers are directly accessible at various I/O addresses. They may be read-only or write-only, and some must be read from and written to at different I/O addresses. Most of the other registers are accessed through a sub-addressing arrangement. The index of the desired register is written to an index register, and then the desired register may be read from or written to through a data port. Almost all of these sub-addressed registers are both readable and writable. Still other registers are directly accessible at various memory addresses and here too, almost all of these registers are both readable and writable.

VGA-Compatible Address Map

Part of the VGA standard requires the VGA graphics system to take the place of either the IBM Monochrome Display and Printer Adapter (either MDPA or MDA) or the IBM Color Graphics Adapter (CGA). This was also the case with the IBM Enhanced Graphics Adapter (EGA), VGA's predecessor. The MDA has registers at I/O addresses 3B4-3B5 and 3BA, and a character buffer (not a frame buffer -- the MDA is a text-only device) within the memory address range of B0000-B7FFF. The CGA has registers within I/O addresses 3D4-3D5 and 3DA-3DC, and a frame buffer (for either text or graphics) within the memory address range of B8000-BFFFF.

The VGA standard introduced numerous modes with features that went beyond those originally provided by either MDA or CGA. To do this, the VGA standard introduced many additional registers at locations in the 3C0-3CF I/O address range, and an additional frame buffer memory space in the A0000-AFFFF memory address range through which the frame buffer could be accessed. This additional memory address region is a 64KB "port-hole" by which the standard 256KB VGA frame buffer is accessed. Either different 64KB portions of this frame buffer are swapped or "paged" in and out of this port-hole as a way of gaining access to all of it, or this frame buffer can be reorganized into "planes" that can be made selectively or even simultaneously accessible through this port-hole as part of a mechanism to enable bit-wise graphics color manipulation. This was done as part of the VGA standard partly because of the shortage of available addresses in the first 1MB of memory address space in PC-standard systems.

If a PC with a VGA graphics system does not have either an MDA display system or a CGA graphics system, the VGA BIOS will initialize the VGA graphics system to take the place of either an MDA if a monochrome display is attached to the VGA, or of a CGA if a color display is attached. However, if a PC with a VGA graphics system also has an MDA display system, the VGA is initialized to take the place of a CGA, regardless of the type of monitor attached to the VGA in order to avoid conflicts with the MDA. Likewise, if a PC with a VGA graphics system also has a CGA graphics system, the VGA is initialized to take the place of an MDA, regardless of the type of monitor attached to the VGA. The VGA standard does not allow a system to have both an MDA display system and a CGA graphics system in the same PC along with a VGA graphics system.

Address Maps for Going Beyond VGA

This graphics controller improves upon VGA by providing additional features that are used through numerous additional registers. Many of these additional registers are simply added to the sub-addressing schemes already defined in the VGA standard, while others are added through sub-addressing schemes using additional I/O address locations 3D0-3D3 and 3D6-3D7. This graphics controller also provides for the memory-mapping of both the standard VGA and these additional registers alongside I/O-mapping. All of the registers that are accessible via I/O addresses 3B0 through 3DF are also accessible at offsets 400760 through 4007BF from the starting address of the upper memory space. Still more of these additional registers are 32 bits wide and for performance reasons are accessible exclusively at other offsets from the starting address of the upper memory space.

This graphics controller also supports 1 or more megabytes of frame buffer memory -- far larger than VGA's standard complement of 256KB. As an improvement upon the VGA standard frame buffer port-hole, this graphics controller also maps the entire frame buffer into part of a single contiguous memory space at a programmable location, providing what is called "linear" access to the frame buffer. The size of this memory space is 16MB (however, the frame buffer does not fill this entire memory space), and the base address is set through a PCI configuration register.

Most aspects of the host interface of this graphics controller are configured through a set of built-in PCI-compliant setup registers. The system logic accesses these registers through standard PCI configuration read and write cycles. Therefore, the exact location of the PCI configuration registers for this graphics controller, as well as any other PCI device in the system I/O or memory address space depends on the system logic design and the system software that configures the system.

PCI Configuration Registers

Configuration Space Offset	Name	Function	Access	Bits
00	VENDID	Vendor ID	read-only	16
02	DEVID	Device ID	read-only	16
04	DEVCTL	Device Control	read/clear	16
06	DEVSTAT	Device Status	read-only	16
08	REV	Revision ID	read-only	8
09	PRG	Programming Interface	read-only	8
0A	SUB	Sub-Class Code	read-only	8
0B	BASE	Base Class Code	read-only	8
0C		Reserved (Cache Line Size)	—	8
0D		Reserved (Latency Timer)	—	8
0E		Reserved (Header Type)	—	8
0F		Reserved (Built-In-Self-Test)	—	8
10	MBASE	Memory Base Address	read/write	32
14		Reserved (Base Address)	—	32
18		Reserved (Base Address)	—	32
1C		Reserved (Base Address)	—	32
20		Reserved (Base Address)	—	32
24		Reserved (Base Address)	—	32
28		Reserved	—	32
2C	SUBVENDID	Subsystem Vendor ID	read-only	16
2E	SUBDEVID	Subsystem Device ID	read-only	16
30	RBASE	ROM Base Address	read/write	32
34		Reserved	—	32
38		Reserved	—	32
3C	INTLINE	Interrupt Line	read/write	8
3D	INTPIN	Interrupt Pin	read-only	8
3E		Reserved (Minimum Grant)	—	8
3F		Reserved (Maximum Latency)	—	8
40 to 6B				
6C	SUBVENDSET	Subsystem Vendor ID Set	read/write	16
6E	SUBDEVSET	Subsystem Device ID Set	read/write	16
6F to FF				

I/O and Sub-Addressed Register Map

I/O Address	Memory Offset	Read	Write
3B0-3B3			
3B4	0x400768	CRTC Index (MDA Emulation)	
3B5	0x400769	CRTC Data Port (MDA Emulation)	
3B6-3B9			
3BA	0x400774	Input Status Register 1 (ST01) (MDA Emulation)	Feature Control Register (FCR) (MDA Emulation)
3BB-3BF			
3C0	0x400780	Attribute Controller Index	Attribute Controller Index and Data Port
3C1	0x400781	Attribute Controller Data Port	Alternate Attribute Controller Data Port
3C2	0x400784	Input Status Register 0 (ST00)	Misc. Output Register (MSR)
3C3			
3C4	0x400788	Sequencer Index	
3C5	0x400789	Sequencer Data Port	
3C6	0x40078C	Color Palette Mask	
3C7	0x40078D	Color Palette State	Color Palette Read Mode Index
3C8	0x400790	Color Palette Write Mode Index	
3C9	0x400791	Color Palette Data Port	
3CA	0x400794	Feature Control Register (FCR)	
3CB			
3CC	0x400798	Misc. Output Register (MSR)	
3CD			
3CE	0x40079C	Graphics Controller Index	
3CF	0x40079D	Graphics Controller Data Port	
3D0	0x4007A0	Flat Panel Extensions Index	
3D1	0x4007A1	Flat Panel Extensions Data Port	
3D2	0x4007A4	Multimedia Extensions Index	
3D3	0x4007A5	Multimedia Extensions Data Port	
3D4	0x4007A8	CRTC Index (CGA Emulation)	
3D5	0x4007A9	CRTC Data Port (CGA Emulation)	
3D6	0x4007AC	Configuration Extensions Index	
3D7	0x4007AD	Configuration Extensions Data Port	
3D8-3D9			
3DA	0x4007B4	Input Status Register 1 (ST01) (CGA Emulation)	Feature Control Register (FCR) (CGA Emulation)
3DB-3DF			

Sub-Addressing Indexes and Data Ports

Index Port Addresses	Data Port Addresses	Register Group	Name	Function
I/O 3C0 Mem 0x400780	I/O 3C0/3C1 Mem 0x400780/781	Attribute Controller	AR0-14	VGA Attributes Control
I/O 3C4 Mem 0x400788	I/O 3C5 Mem 0x400789	Sequencer	SR0-7	VGA Sequencer Control
I/O 3CE Mem 0x40079C	I/O 3CF Mem 0x40079D	Graphics Controller	GR0-8	VGA Data Path Control
I/O 3D0 Mem 0x4007A0	I/O 3D1 Mem 0x4007A1	Flat Panel	FR00-1F FR20-2F FR30-3F FR40-47 FR48-4F FR50-5F FR60-6F FR70-7F	General Panel Control Horizontal Panel Timing Vertical Panel Timing Horizontal Compensation Vertical Compensation — — —
I/O 3D2 Mem 0x4007A4	I/O 3D3 Mem 0x4007A5	Multimedia	MR00-1F MR20-3F MR40-5F MR60-7F	Acquisition/Capture Playback Window Display Color Key —
I/O 3B4/3D4 Mem 0x400768/7A8	I/O 3B5/3D5 Mem 0x400769/7A9	CRTC	CR00-2F CR30-3F CR40-4F CR50-5F CR60-6F CR70-7F CR80-FF	Basic Display Control Timing Extension Bits Address Extension Bits Display Overlay — Interlace Control —
I/O 3D6 Mem 0x4007AC	I/O 3D7 Mem 0x4007AD	Extension Registers	XR00-0F XR10-1F XR20-2F XR30-3F XR40-4F XR50-5F XR60-6F XR70-7F XR80-8F XR90-9F XRA0-AF XRB0-BF XRC0-CF XRD0-DF XRE0-EF XRF0-FF	General Configuration — Graphics Engine Configuration — Memory Configuration — Pin Control Configuration Pins Pixel Pipeline — Hardware Cursor — Clock Control Power Management Software Flags Hardware Testing

Lower Memory Map

Address Range	Function	Size in Bytes
A0000-AFFFF	VGA Frame Buffer	64KB
B0000-B7FFF	MDA Emulation Character Buffer	32KB
B8000-BFFFF	CGA Emulation Frame Buffer	32KB
C0000-C7FFF or C0000 up to CFFFF	VGA BIOS ROM	32KB or Larger (up to 64KB)

Upper Memory Map

Size		Memory Offset	Function	
16MB	8MB	2MB	0x000000 to 0x1FFFFFF Linear Frame Buffer (Little-Endian)	
		2MB	0x200000 to 0x3FFFFFF	
	4MB	2KB	64 Bytes	0x400000 to 0x40003F BitBLT Registers (Little-Endian)
			1472 Bytes	0x400040 to 0x4005FF
			64 Bytes	0x400600 to 0x40063F ER Registers (Little-Endian)
			192 Bytes	0x400640 to 0x4006FF
			256 Bytes	0x400700 to 0x4007FF VGA and Sub-Addressed Registers (Little-Endian)
		62KB	0x400800 to 0x40FFFF	
		64KB	0x410000 to 0x41FFFF BitBLT Data Port (Little-Endian)	
	3968KB	0x420000 to 0x7FFFFFFF		
	8MB	2MB	0x800000 to 0x9FFFFFF Linear Frame Buffer (Big-Endian)	
		2MB	0xA00000 to 0xBFFFFFF	
		4MB	64KB	0xC00000 to 0xC0FFFF
			64KB	0xC10000 to 0xC1FFFF BitBLT Data Port (Big-Endian)
3968KB			0xC20000 to 0xFFFFF	

Chapter 6

Register Summaries

Table 6-1 PCI Configuration Registers

Configuration Space Offset	Name	Register Function	Access	Bits
00	VENDID	Vendor ID Register	read-only	16
02	DEVID	Device ID Register	read-only	16
04	DEVCTL	Device Control Register	read/clear	16
06	DEVSTAT	Device Status Register	read-only	16
08	REV	Revision ID Register	read-only	8
09	PRG	Programming Interface Register	read-only	8
0A	SUB	Sub-Class Code Register	read-only	8
0B	BASE	Base Class Code Register	read-only	8
0C		Reserved (Cache Line Size)	—	8
0D		Reserved (Latency Timer)	—	8
0E		Reserved (Header Type)	—	8
0F		Reserved (Built-In-Self-Test)	—	8
10	MBASE	Memory Base Address Register	read/write	32
14		Reserved (Base Address)	—	32
18		Reserved (Base Address)	—	32
1C		Reserved (Base Address)	—	32
20		Reserved (Base Address)	—	32
24		Reserved (Base Address)	—	32
28		Reserved	—	32
2C	SUBVENDID	Subsystem Vendor ID Register	read-only	16
2E	SUBDEVID	Subsystem Device ID Register	read-only	16
30	RBASE	ROM Base Address Register	read/write	32
34		Reserved	—	32
38		Reserved	—	32
3C	INTLINE	Interrupt Line Register	read/write	8
3D	INTPIN	Interrupt Pin Register	read-only	8
3E		Reserved (Minimum Grant)	—	8
3F		Reserved (Maximum Latency)	—	8
40 to 6B				
6C	SUBVENDSET	Subsystem Vendor ID Set Register	read/write	16
6E	SUBDEVSET	Subsystem Device ID Set Register	read/write	16
6F to FF				

Table 6-2: General Control & Status Registers

Name	Register Function	Read	Write
ST00	VGA Input Status Register 0	3C2	—
ST01	VGA Input Status Register 1	3BA/3DA	—
FCR	VGA Feature Control Register	3CA	3BA/3DA
MSR	VGA Miscellaneous Output Register	3CC	3C2

Table 6-3: CRT Controller Registers

Name	Register Function	Access 3B5/3D5	Index Value 3B4/3D4 (CRX)
CR00	Horizontal Total Register	read/write	00h
CR01	Horizontal Display Enable End Register	read/write	01h
CR02	Horizontal Blanking Start Register	read/write	02h
CR03	Horizontal Blanking End Register	read/write	03h
CR04	Horizontal Sync Start Register	read/write	04h
CR05	Horizontal Sync End Register	read/write	05h
CR06	Vertical Total Register	read/write	06h
CR07	Overflow Register	read/write	07h
CR08	Preset Row Scan Register	read/write	08h
CR09	Maximum Scanline Register	read/write	09h
CR0A	Text Cursor Start Scanline Register	read/write	0Ah
CR0B	Text Cursor End Scanline Register	read/write	0Bh
CR0C	Start Address High Register	read/write	0Ch
CR0D	Start Address Low Register	read/write	0Dh
CR0E	Text Cursor Location High Register	read/write	0Eh
CR0F	Text Cursor Location Low Register	read/write	0Fh
CR10	Vertical Sync Start Register	read/write	10h
CR11	Vertical Sync End Register	read/write	11h
CR12	Vertical Display Enable End Register	read/write	12h
CR13	Offset Register	read/write	13h
CR14	Underline Row Register	read/write	14h
CR15	Vertical Blanking Start Register	read/write	15h
CR16	Vertical Blanking End Register	read/write	16h
CR17	CRT Mode Control Register	read/write	17h
CR18	Line Compare Register	read/write	18h
CR22	Memory Read Latch Data Register	read-only	22h
CR30	Extended Vertical Total Register	read/write	30h
CR31	Extended Vertical Display End Register	read/write	31h
CR32	Extended Vertical Sync Start Register	read/write	32h
CR33	Extended Vertical Blanking Start Register	read/write	33h
CR38	Extended Horizontal Total Register	read/write	38h
CR3C	Extended Horizontal Blanking End Register	read/write	3Ch
CR40	Extended Start Address Register	read/write	40h
CR41	Extended Offset Register	read/write	41h
CR70	Interlace Control Register	read/write	70h
CR71	NTSC/PAL Video Output Control Register	read/write	71h
CR72	NTSC/PAL Horizontal Serration 1 Start Register	read/write	72h
CR73	NTSC/PAL Horizontal Serration 2 Start Register	read/write	73h
CR74	NTSC/PAL Horizontal Pulse Width Register	read/write	74h
CR75	NTSC/PAL Filtering Burst Read Length Register	read/write	75h
CR76	NTSC/PAL Filtering Burst Read Quantity Register	read/write	76h
CR77	NTSC/PAL Filtering Control Register	read/write	77h
CR78	NTSC/PAL Vertical Reduction Register	read/write	78h
CR79	NTSC/PAL Pixel Resolution Fine Adjust Register	read/write	79h

Note: CR00-CR22 are standard VGA registers -- all other CR registers are CHIPS extensions.

Table 6-4: Sequencer Registers

Name	Register Function	Access (via 3C5)	Index Value In 3C4 (SRX)
SR00	Reset Register	read/write	00
SR01	Clocking Mode Register	read/write	01
SR02	Map Mask Register	read/write	02
SR03	Character Map Select Register	read/write	03
SR04	Memory Mode Register	read/write	04
SR07	Horizontal Character Counter Reset Register	read/write	07

Table 6-5: Graphics Controller Registers

Name	Register Function	Access (via 3CF)	Index Value In 3CE (GRX)
GR00	Set/Reset Register	read/write	00h
GR01	Enable Set/Reset Register	read/write	01h
GR02	Color Compare Register	read/write	02h
GR03	Data Rotate Register	read/write	03h
GR04	Read Map Select Register	read/write	04h
GR05	Graphics Mode Register	read/write	05h
GR06	Miscellaneous Register	read/write	06h
GR07	Color Don't Care Register	read/write	07h
GR08	Bit Mask Register	read/write	08h

Table 6-6: Attribute Controller Registers

Name	Register Function	Access (via 3C0/3C1)	Index Value In 3C0 (ARX)
AR00-AR0F	Color Data Registers	read/write	00-0F
AR10	Mode Control Register	read/write	10
AR11	Overscan Color Register	read/write	11
AR12	Memory Plane Enable Register	read/write	12
AR13	Horizontal Pixel Panning Register	read/write	13
AR14	Color Select Register	read/write	14

Table 6-7: Palette Registers

Name	Register Function	Access (via 3C9)	I/O Address In 3C7/3C8
PALMASK	Palette Mask Register	read/write	3C6h
PALSTATE	Palette State Register	read-only	3C7h
PALRX	Palette Read Index Register	write-only	3C7h
PALWX	Palette Write Index Register	read/write	3C8h
PALDATA	Palette Data Register	read/write	3C9h

Table 6-8: Extension Registers

Name	Register Function	Access (via 3D7)	Index Value In 3D6 (XRX)
XR00	Vendor ID Low Register	read-only	00h
XR01	Vendor ID High Register	read-only	01h
XR02	Device ID Low Register	read-only	02h
XR03	Device ID High Register	read-only	03h
XR04	Revision ID Register	read-only	04h
XR05	Linear Base Address Low Register	read-only	05h
XR06	Linear Base Address High Register	read-only	06h
XR08	Host Bus Configuration Register	read-only	08h
XR09	I/O Control Register	read/write	09h
XR0A	Frame Buffer Mapping Register	read/write	0Ah
XR0B	PCI Burst Write Support Register	read/write	0Bh
XR0E	Frame Buffer Page Select Register	read/write	0Eh
XR20	BitBLT Configuration Register	read/write	20h
XR40	Memory Access Control Register	read/write	40h
XR41-XR4F	Memory Configuration Registers	read/write	41h-4Fh
XR60	Video Pin Control Register	read/write	60h
XR61	DPMS Sync Control Register	read/write	61h
XR62	GPIO Pin Control Register	read/write	62h
XR63	GPIO Pin Data Register	read/write	63h
XR67	Pin Tri-State Control Register	read/write	67h
XR70	Configuration Pins 0 Register	read-only	70h
XR71	Configuration Pins 1 Register	read-only	71h
XR80	Pixel Pipeline Configuration 0 Register	read/write	80h
XR81	Pixel Pipeline Configuration 1 Register	read/write	81h
XR82	Pixel Pipeline Configuration 2 Register	read/write	82h

Table 6-8: Extension Registers(continued)

Name	Register Function	Access Via Port 3D7	Index Value Port 3D6 (XRX)
XRA0	Cursor 1 Control Register	read/write	A0h
XRA1	Cursor 1 Vertical Extension Register	read/write	A1h
XRA2	Cursor 1 Base Address Low Register	read/write	A2h
XRA3	Cursor 1 Base Address High Register	read/write	A3h
XRA4	Cursor 1 X-Position Low Register	read/write	A4h
XRA5	Cursor 1 X-Position High Register	read/write	A5h
XRA6	Cursor 1 Y-Position Low Register	read/write	A6h
XRA7	Cursor 1 Y-Position High Register	read/write	A7h
XRA8	Cursor 2 Control Register	read/write	A8h
XRA9	Cursor 2 Vertical Extension Register	read/write	A9h
XRAA	Cursor 2 Base Address Low Register	read/write	AAh
XRAB	Cursor 2 Base Address High Register	read/write	ABh
XRAC	Cursor 2 X-Position Low Register	read/write	ACh
XRAD	Cursor 2 X-Position High Register	read/write	ADh
XRAE	Cursor 2 Y-Position Low Register	read/write	A Eh
XRAF	Cursor 2 Y-Position High Register	read/write	AFh
XRC0	Dot Clock 0 VCO M-Divisor Low Register	read/write	C0h
XRC1	Dot Clock 0 VCO N-Divisor Low Register	read/write	C1h
XRC2	Dot Clock 0 VCO M/N-Divisor High Register	read/write	C2h
XRC3	Dot Clock 0 Divisor Select Register	read/write	C3h
XRC4	Dot Clock 1 VCO M-Divisor Low Register	read/write	C4h
XRC5	Dot Clock 1 VCO N-Divisor Low Register	read/write	C5h
XRC6	Dot Clock 1 VCO M/N-Divisor High Register	read/write	C6h
XRC7	Dot Clock 1 Divisor Select Register	read/write	C7h
XRC8	Dot Clock 2 VCO M-Divisor Low Register	read/write	C8h
XRC9	Dot Clock 2 VCO N-Divisor Low Register	read/write	C9h
XRCA	Dot Clock 2 VCO M/N-Divisor High Register	read/write	CAh
XRCB	Dot Clock 2 Divisor Select Register	read/write	CBh
XRCC	Memory Clock VCO M-Divisor Register	read/write	CCh
XRCD	Memory Clock VCO N-Divisor Register	read/write	CDh
XRCE	Memory Clock VCO Divisor Select Register	read/write	CEh
XRCF	Clock Configuration Register	read/write	CFh
XRD0	Powerdown Control Register	read/write	D0h
XRD1	Power Conservation Control Register	read/write	D1h
XRD2	2KHz Down Counter Register	read-only	D2h
XRE0-XRE9	Software Flag Registers	read/write	E0h-E9h
XRF8-XRFC	Test Registers	read/write	F8h-FCh

Table 6-9: Flat Panel Registers

Name	Register Function	Access Via Port 3D1h	Index Value Port 3D0h
FR00	Feature Register	read-only	00h
FR01	CRT / FP Control Register	read/write	01h
FR02	FP Mode Control Register	read/write	02h
FR03	FP Dot Clock Source Register	read/write	03h
FR04	Panel Power Sequencing Delay Register	read/write	04h
FR05	Power Down Control 1 Register	read/write	05h
FR06	FP Power Down Control Register	read/write	06h
FR08	FP Pin Polarity Register	read/write	08h
FR0A	Programmable Output Drive Register	read/write	0Ah
FR0B	FP Pin Control 1 Register	read/write	0Bh
FR0C	Pin Control 2 Register	read/write	0Ch
FR0F	Activity Timer Control Register	read/write	0Fh
FR10	FP Format 0 Register	read/write	10h
FR11	FP Format 1 Register	read/write	11h
FR12	FP Format 2 Register	read/write	12h
FR13	FP Format 3 Register	read/write	13h
FR16	FRC Option Select Register	read/write	16h
FR17	Polynomial FRC Control Register	read/write	17h
FR18	FP Text Mode Control Register	read/write	18h
FR19	Blink Rate Control Register	read/write	19h
FR1A	STN-DD Buffering Control Register	read/write	1Ah
FR1E	M (ACDCLK) Control Register	read/write	1Eh
FR1F	Diagnostic Register	read/write	1Fh
FR20	FP Horizontal Panel Display Size LSB Register	read/write	20h
FR21	FP Horizontal Sync Start LSB Register	read/write	21h
FR22	FP Horizontal Sync End Register	read/write	22h
FR23	FP Horizontal Total LSB Register	read/write	23h
FR24	FP HSync (LP) Delay LSB Register	read/write	24h
FR25	FP Horizontal Overflow 1 Register	read/write	25h
FR26	FP Horizontal Overflow 2 Register	read/write	26h
FR27	FP HSync (LP) Width and Disable Register	read/write	27h
FR30	FP Vertical Panel Size LSB Register	read/write	30h
FR31	FP Vertical Sync Start LSB Register	read/write	31h
FR32	FP Vertical Sync End Register	read/write	32h
FR33	FP Vertical Total LSB Register	read/write	33h
FR34	FP VSync (FLM) Delay LSB Register	read/write	34h
FR35	FP Vertical Overflow 1 Register	read/write	35h
FR36	FP Vertical Overflow 2 Register	read/write	36h
FR37	FP VSync (FLM) Disable Register	read/write	37h
FR40	Horizontal Compensation Register	read/write	40h
FR41	Horizontal Stretching Register	read/write	41h
FR48	Vertical Compensation Register	read/write	48h
FR49-4C	Text Mode Vertical Stretching 0 MSB Registers	read/write	49h-4Ch
FR4D	Vertical Line Replication Register	read/write	4Dh
FR4E	Selective Vertical Stretching Disable Register	read/write	4Eh
FR70	TMED Red Seed Register	read/write	70h
FR71	TMED Green Seed Register	read/write	71h
FR72	TMED Blue Seed Register	read/write	72h
FR73	TMED Control Register	read/write	73h
FR74	TMED2 Shift Control Register	read/write	74h

Table 6-10: Multimedia Registers

Name	Register Function	Access Via 3D3h	Index at 3D2h Set to Value
MR00	Module Capability Register	read-only	00h
MR01	Secondary Capability Register	read-only	01h
MR02	Capture Control 1 Register	read/write	02h
MR03	Capture Control 2 Register	read/write	03h
MR04	Capture Control 3 Register	read/write	04h
MR05	Capture Control 4 Register	read/write	05h
MR06-08	Capture Memory Address PTR1 Register	read/write	06h - 08h
MR09-0B	Capture Memory Address PTR2 Register	read/write	09h - 0Bh
MR0C	Capture Memory Width (Span) Register	read/write	0Ch
MR0E	Capture Window X-LEFT Low Register	read/write	0Eh
MR0F	Capture Window X-LEFT High Register	read/write	0Fh
MR10	Capture Window X-RIGHT Low Register	read/write	10h
MR11	Capture Window X-RIGHT High Register	read/write	11h
MR12	Capture Window Y-TOP Low Register	read/write	12h
MR13	Capture Window Y-TOP High Register	read/write	13h
MR14	Capture Window Y-BOTTOM Low Register	read/write	14h
MR15	Capture Window Y-BOTTOM High Register	read/write	15h
MR16	H-SCALE Register	read/write	16h
MR17	V-SCALE Register	read/write	17h
MR18	Capture Frame Count Register	read/write	18h
MR1E	Playback Control 1 Register	read/write	1Eh
MR1F	Playback Control 2 Register	read/write	1Fh
MR20	Playback Control 3 Register	read/write	20h
MR21	Double Buffer Status Register	read/write	21h
MR22-24	Playback Memory Address PTR1 Register	read/write	22h - 24h
MR25-27	Playback Memory Address PTR2 Register	read/write	25h - 27h
MR28	Playback Memory Line Fetch Width Register	read/write	28h
MR2A	Playback Window X-LEFT Low Register	read/write	2Ah
MR2B	Playback Window X-LEFT High Register	read/write	2Bh
MR2C	Playback Window X-RIGHT Low Register	read/write	2Ch
MR2D	Playback Window X-RIGHT High Register	read/write	2Dh
MR2E	Playback Window Y-TOP Low Register	read/write	2Eh
MR2F	Playback Window Y-TOP High Register	read/write	2Fh
MR30	Playback Window Y-BOTTOM Low Register	read/write	30h
MR31	Playback Window Y-BOTTOM High Register	read/write	31h
MR32	H-ZOOM Register	read/write	32h
MR33	V-ZOOM Register	read/write	33h
MR34	Memory Line Out Total Register	read/write	34h
MR3C	Color Key Control 1 Register	read/write	3Ch
MR3D-3F	Color Keys Register	read/write	3Dh - 3Fh
MR40-42	Color Key Masks Register	read/write	40h - 42h
MR43	Line Count Low Register	read-only	43h
MR44	Line Count High Register	read-only	44h

Table 6-11: BitBLT Registers

Name	Function	Access	Offset
BR00	Source and Destination Offset Register	read/write	0x400000
BR01	Pattern/Source Expansion Background Color Register	read/write	0x400004
BR02	Pattern/Source Expansion Foreground Color Register	read/write	0x400008
BR03	Monochrome Source Control Register	read/write	0x40000C
BR04	BitBLT Control Register	read/write	0x400010
BR05	Pattern Address Register	read/write	0x400014
BR06	Source Address Register	read/write	0x400018
BR07	Destination Address Register	read/write	0x40001C
BR08	Destination Width & Height Register	read/write	0x400020
BR09	Source Expansion Background Color Register	read/write	0x400024
BR0A	Source Expansion Foreground Color Register	read/write	0x400028

Table 6-12: Memory Mapped Wide Extension Registers

Name	Function	Access	Offset
ER00	Central Interrupt Control Register	read/write	0x400100
ER01	Central Interrupt Status Register	read/write	0x400104
ER03	Miscellaneous Function Register	read/write	0x40010C

Chapter 7

PCI Configuration Registers

Table 7-1 PCI Configuration Registers

Configuration Space Offset	Name	Function	Access	Bits
00	VENDID	Vendor ID Register	read-only	16
02	DEVID	Device ID Register	read-only	16
04	DEVCTL	Device Control Register	read/clear	16
06	DEVSTAT	Device Status Register	read-only	16
08	REV	Revision ID Register	read-only	8
09	PRG	Programming Interface Register	read-only	8
0A	SUB	Sub-Class Code Register	read-only	8
0B	BASE	Base Class Code Register	read-only	8
0C		Reserved (Cache Line Size)	—	8
0D		Reserved (Latency Timer)	—	8
0E		Reserved (Header Type)	—	8
0F		Reserved (Built-In-Self-Test)	—	8
10	MBASE	Memory Base Address Register	read/write	32
14		Reserved (Base Address)	—	32
18		Reserved (Base Address)	—	32
1C		Reserved (Base Address)	—	32
20		Reserved (Base Address)	—	32
24		Reserved (Base Address)	—	32
28		Reserved	—	32
2C	SUBVENDID	Subsystem Vendor ID Register	read-only	16
2E	SUBDEVID	Subsystem Device ID Register	read-only	16
30	RBASE	ROM Base Address Register	read/write	32
34		Reserved	—	32
38		Reserved	—	32
3C	INTLINE	Interrupt Line Register	read/write	8
3D	INTPIN	Interrupt Pin Register	read-only	8
3E		Reserved (Minimum Grant)	—	8
3F		Reserved (Maximum Latency)	—	8
40 to 6B				
6C	SUBVENDSET	Subsystem Vendor ID Set Register	read/write	16
6E	SUBDEVSET	Subsystem Device ID Set Register	read/write	16
6F to FF				

Note: The mechanism used to generate the PCI configuration read and configuration write cycles by which these registers are accessed is system-dependent.

VENDID Vendor ID Register

read-only at PCI configuration offset 00h

byte or word accessible

accessible only via PCI configuration cycles

15	14	13	12	11	10	9	8	7	6	5	4	3	2	1	0
Vendor ID (102Ch)															

15-0 Vendor ID

This is the vendor ID assigned to CHIPS by the PCI Special Interest group. This register always returns the 16-bit value 102Ch (4140 decimal).

DEVID Device ID Register

read-only at PCI configuration offset 02h

byte or word accessible

accessible only via PCI configuration cycles

15	14	13	12	11	10	9	8	7	6	5	4	3	2	1	0
Device ID (00C0h)															

15-0 Device ID

This is the device ID assigned to the 69000 by CHIPS. This register always returns the 16-bit value 00C0h when read.

DEVCTL Device Control Register

read/write at PCI configuration offset 04h

byte or word accessible

accessible only via PCI configuration cycles

15	14	13	12	11	10	9	8	7	6	5	4	3	2	1	0
Reserved						Fast Bk-Bk	SERR Enbl	Wait Cycl Ctl	PERR Enbl	VGA Pal Snoop	Mem Wrt / Inval.	Spec Cycl	Bus Mstr	Mem Acc	I/O Acc
(0000:00)						(0)	(0)	(1)	(0)	(0)	(0)	(0)	(0)	(0)	(0)

15-10 Reserved

Each of these bits always return a value of 0 when read.

9 Fast Back-to-Back Enable for Masters

This bit applies only to PCI Bus masters. Since this graphics controller never functions as a PCI Bus master, this bit always returns a value of 0 when read.

8 SERR# Enable

0: Disables the use of SERR# and the setting of bit 14 (Signaled System Error bit) in the Device Status Register (DEVSTAT) to 1 as a response to an address parity error. This is the default after reset.

1: Enables the use of SERR# and the setting of bit 14 (Signaled System Error bit) in the Device Status Register (DEVSTAT) to 1 as a response to an address parity error.

7 Wait Cycle Control

This bit controls enables and disables address stepping. Since this graphics controller always supports address stepping, this bit always returns a value of 1 when read.

6 Parity Error Response

0: Disables the use of PERR# as a response to detecting either data or address parity errors. Disables the setting of bit 14 (Signaled System Error bit) in the Device Status Register (DEVSTAT) to 1 as a response to an address parity error. This is the default after reset.

1: Enables the use of PERR# as a response to detecting either data or address parity errors. Enables the setting of bit 14 (Signaled System Error bit) in the Device Status Register (DEVSTAT) to 1 as a response to an address parity error.

Note: Bit 8 (SERR# Enable) of this register must also be set to 1 to enable the use of SERR# and the setting of bit 14 (Signaled System Error bit) in the Device Status Register (DEVSTAT) to 1 as a response to an address parity error.

5 VGA Palette Snoop

0: Accesses to all VGA I/O locations including those for the palette will be claimed. All read and write accesses to the palette will be performed normally. This is the default after reset.

1: Accesses to all VGA I/O locations, except for those for the palette, will be claimed. All reads will be entirely ignored, but all writes will still update the palette. This permits accesses to the palette I/O addresses to be answered by other devices that need to be able to snoop accesses to the palette.

4 Memory Write & Invalidate

This bit applies only to PCI Bus masters. Since this graphics controller never functions as a PCI Bus master, this bit always returns a value of 0 when read.

3 Special Cycles

This graphics controller always ignores all special cycles, therefore this bit always returns the value of 0 when read.

2 Bus Master

This graphics controller never functions as a PCI Bus master, therefore this bit always returns a value of 0 when read.

1 Memory Access Enable

0: Disables access to the frame buffer memory locations within the range specified by the MBASE Register. This is the default after reset.

1: Enables access to the frame buffer memory locations within the range specified by the MBASE Register.

Note: Accesses with only adjacent active byte enables are supported.

0 I/O Access Enable

0: Disables I/O port accesses. This is the default after reset.

1: Enables I/O port accesses.

Note: Accesses with only adjacent active byte enables are supported.

DEVSTAT Device Status Register

read/write at PCI configuration offset 06h

byte or word accessible

accessible only via PCI configuration cycles

15	14	13	12	11	10	9	8	7	6	5	4	3	2	1	0
Det Parity Error (0)	Signal System Error (0)	Rcvd Master Abort (0)	Rcvd Target Abort (0)	Signal Target Abort (0)	DEVSEL# Timing (01)		Data Parity Error (0)	Fast Back- Back (1)	UDF (0)	66 MHz (0)	Reserved (0:0000)				

Important: Read accesses to this register behave normally. Writes, however, behave differently in that bits can be reset to 0, but not set to 1. A bit in this register is reset to 0 whenever it is written with the value of 1. Bits written with a value of 0 are entirely unaffected.

15 Detected Parity Error

- 0: No address or data parity error detected.
- 1: An address or data parity error was detected.

Note: This bit is set in response to a parity error regardless of the settings of either bit 6 (Parity Error Response bit) and 8 (SERR# Enable) of the Device Control Register (DEVCTL).

14 Signaled System Error

- 0: SERR# has not been asserted.
- 1: SERR# has been asserted.

Note: Both bits 6 (Parity Error Response bit) and 8 (SERR# Enable) of the Device Control Register (DEVCTL) must both be set to 1 to enable the use of SERR# and the setting of this bit to 1 in response to an address parity error.

13 Received Master Abort

This bit applies only to PCI Bus masters. Since the 69000 never functions as a PCI Bus master, this bit always returns a value of 0 when read.

12 Received Target Abort

This bit applies only to PCI Bus masters. Since the 69000 never functions as a PCI Bus master, this bit always returns a value of 0 when read.

11 Signaled Target Abort

- 0: A target abort was not generated.
 - 1: A target abort was generated.
- A target abort can be generated by the 69000 on I/O cycles with non-adjacent active byte enables.

10-9 DEVSEL# Timing

These two bits specify the longest-possible amount of time that the 69000 will take in decoding an address and asserting DEVSEL#. These two bits always return a value of 01, indicating a medium-length timing.

8 Data Parity Error Detected

This bit applies only to PCI Bus masters. Since the 69000 never functions as a PCI Bus master, this bit always returns a value of 0 when read.

7 Fast Back-to-Back Capable

This bit always returns a value of 1 when read, indicating that the 69000 is capable of fast back-to-back transactions that are not in the same segment.

6 UDF Supported

This bit always returns a value of 0 when read, indicating that the 69000 does not provide features that are definable by the end-user.

5 66MHz Capable

This bit always returns a value of 0 when read, indicating that the 69000 can support a maximum PCI Bus speed of 33MHz, not 66MHz.

4-0 Reserved

Each of these bits always return a value of 0 when read.

REV Revision ID Register

read-only at PCI configuration offset 08h

byte accessible

accessible only via PCI configuration cycles

7	6	5	4	3	2	1	0
Chip Manufacturing Code (xxxx)				Chip Revision Code (xxxx)			

Note: This register is identical to the Revision ID Register (XR04).

7-4 Chip Manufacturing Code

These four bits carry the fabrication code.

3-0 Chip Revision Code

These four bits carry the revision code. Revision codes start at 0 and are in increments for each new silicon revision.

PRG Register-Level Programming Interface Register

read-only at PCI configuration offset 09h

byte accessible

accessible only via PCI configuration cycles

7	6	5	4	3	2	1	0
Register-Level Programming Interface (00h)							

7-0 Register-Level Programming Interface

This register always returns a value of 00h to identify this PCI device as a display controller with a VGA-compatible programming interface (as opposed to 01h, which would indicate a display controller with a 8514/A-compatible programming interface).

SUB Sub-Class Code Register

read-only at PCI configuration offset 0Ah

byte accessible

accessible only via PCI configuration cycles

7	6	5	4	3	2	1	0
Sub-Class Code (00h)							

7-0 Sub-Class Code

This register always returns a value of 00h to identify this PCI device as a display controller of the VGA or 8514/A type.

BASE Base Class Code Register

read-only at PCI configuration offset 0Bh

byte accessible

accessible only via PCI configuration cycles

7	6	5	4	3	2	1	0
Base Class Code (03h)							

7-0 Base Class Code

This register always returns a value of 03h to identify this PCI device as a display controller.

HDR Header Type Register

read-only at PCI configuration offset 0Eh

byte accessible

accessible only via PCI configuration cycles

7	6	5	4	3	2	1	0
Single/Multi Function Dev (0)	Reserved (000:0000)						

7 Single/Multiple Function Device

This bit always returns a value of 0 when read, indicating that this PCI device is a single-function device, not a multi-function device.

6-0 Reserved

Each of these bits always return a value of 0 when read.

MBASE Memory Base Address Register

read/write at PCI configuration offset 10h

byte, word, or doubleword accessible

accessible only via PCI configuration cycles

31	30	29	28	27	26	25	24	23	22	21	20	19	18	17	16
Memory Space Base Address (0000:0000)								Memory Space Size (0000:0000)							
15	14	13	12	11	10	9	8	7	6	5	4	3	2	1	0
Memory Space Size (0000:0000:0000)											Pref. (0)	Memory Type (00)	M or I/O (0)		

31-24 Memory Space Base Address

These 8 bits select the base address for this 16MB memory space used by the 65555 for the memory mapped registers and linear accesses to the frame buffer.

23-4 Memory Space Size

These 20 bits always return 0 to indicate that the size of this memory space is 16MB.

3 Prefetchable

This bit always returns a value of 0 when read, indicating that the data in this 16MB memory space should not be prefetched by the CPU.

2-1 Memory Type

These 2 bits always return values of 0 when read, indicating that this 16MB memory space may be placed anywhere in the system's 32-bit address space by the system's PCI configuration software.

0 Memory/I/O Space Indicator

This bit always returns a value of 0 when read, indicating that this is a memory space, not an I/O space.

SUBVENDID Subsystem Vendor ID Register

read-only at PCI configuration offset 2Ch

byte or word accessible

accessible only via PCI configuration cycles

15	14	13	12	11	10	9	8	7	6	5	4	3	2	1	0
Subsystem Vendor ID (102Ch)															

15-0 Subsystem Vendor ID

These bits are intended to carry the vendor ID of the vendor of the subsystem in which this graphics controller is used, such as an add-in graphics card. After reset, this register defaults to 102Ch, the vendor ID assigned to CHIPS by the PCI special interest group. The vendor ID of the actual subsystem vendor must be programmed into this graphics controller by writing it to the SUBVENDSET register in the PCI configuration space at offset 6Ch.

SUBDEVVID Subsystem Device ID Register

read-only at PCI configuration offset 2Eh

byte or word accessible

accessible only via PCI configuration cycles

15	14	13	12	11	10	9	8	7	6	5	4	3	2	1	0
Subsystem Device ID (00C0h)															

15-0 Subsystem Vendor ID

These bits are intended to carry the device ID of the vendor of the subsystem in which this graphics controller is used, such as an add-in graphics card. After reset, this register defaults to 00C0h, the vendor ID assigned to the 69000 by CHIPS. The device ID desired by actual subsystem vendor must be programmed into this graphics controller by writing it to the SUBDEVSET register in the PCI configuration space at offset 6Eh.

INTLINE Interrupt Line Register

read/write at PCI configuration offset 3Ch

byte accessible

accessible only via PCI configuration cycles

7	6	5	4	3	2	1	0
Interrupt Line (00h)							

7-0 Interrupt Line

This register carries the level number of the interrupt line to which the interrupt output is routed by the host system. The graphics controller does not use the information in this register. The data is normally written to with the value determined by the host system's POST code, and then later read by other software to find out which interrupt level on the host CPU should be 'hooked' by interrupt software.

INTPIN Interrupt Pin Register

read-only at PCI configuration offset 3Dh

byte accessible

accessible only via PCI configuration cycles

7	6	5	4	3	2	1	0
Interrupt pin (01h)							

7-0 Sub-class Code

This register always returns a value of 01h to indicate that the interrupt output should be connected to the INTA# signal.

RBASE ROM Base Address Register

read/write at PCI configuration offset 30h

byte, word, or doubleword accessible

accessible only via PCI configuration cycles

31	30	29	28	27	26	25	24	23	22	21	20	19	18	17	16
ROM Space Base Address (0000:0000:0000:00)														ROM Space Size (00)	
15	14	13	12	11	10	9	8	7	6	5	4	3	2	1	0
ROM Space Size (0000:0000:0000:000)														Addr Enbl (0)	

31-18 ROM Space Base Address

These 14 bits select the base address for this 256KB ROM space used by the 65555 for the video BIOS ROM.

17-1 ROM Space Size

These 17 bits always return 0 to indicate that the size of this ROM space is 256KB.

0 Address Decode Enable

- 0: Disable access to the video BIOS ROM. This is the default after reset.
- 1: Enable access to the video BIOS ROM.

Note: Bit 1 of the Device Control register (DEVCTL) must also be set to 1 for the video BIOS ROM to be accessible. Also, the ROM address space must not be programmed to a range that overlaps the area specified by the MBASE register.

SUBVENDSET Subsystem Vendor ID Set Register

read/write at PCI configuration offset 6Ch

byte or word accessible

accessible only via PCI configuration cycles

15	14	13	12	11	10	9	8	7	6	5	4	3	2	1	0
Subsystem Vendor ID Set (102Ch)															

15-0 Subsystem Vendor ID Set

These bits are used to program the vendor ID of the vendor of the subsystem in which this graphics controller is used, such as an add-in graphics card. After reset, this register defaults to 102Ch, the vendor ID assigned to CHIPS by the PCI special interest group. The vendor ID of the actual subsystem vendor must be programmed into the graphics controller by writing it to this register.

SUBDEVSET Subsystem Device ID Set Register

read/write at PCI configuration offset 6Eh

byte or word accessible

accessible only via PCI configuration cycles

15	14	13	12	11	10	9	8	7	6	5	4	3	2	1	0
Subsystem Device ID Set (00C0h)															

15-0 Subsystem Device ID Set

These bits are intended to program the device ID specified by the vendor of the subsystem in which this graphics controller is used, such as an add-in graphics card. After reset this register defaults to 00C0h, the device ID assigned to this graphics controller by CHIPS. The device ID desired by the actual subsystem vendor must be programmed into this graphics controller by writing it to this register.

Chapter 8

General Control and Status Registers

These are direct-access registers -- they are NOT read from or written to using any form of sub-indexing scheme.

Name	Function	Read	Write
ST00	Input Status Register 0	3C2	—
ST01	Input Status Register 1	3BA/3DA	—
FCR	Feature Control Register	3CA	3BA/3DA
MSR	Miscellaneous Output Register	3CC	3C2

Various bits in these registers have bits that provide control over the real-time status of the horizontal sync signal, the horizontal retrace interval, the vertical sync signal, and the vertical retrace interval.

The horizontal retrace interval is the time when the drawing of each horizontal line has active video data, when the active video data is not being displayed. It is the time that includes the horizontal front and back porches, and the horizontal sync pulse. The horizontal retrace interval is always longer than the horizontal sync pulse.

The vertical retrace interval is the period during the drawing of each screen, when the horizontal lines with active video data are not drawn. This period includes the vertical front and back porches, and the vertical sync pulse. The vertical retrace interval is always longer than the vertical sync pulse.

The 'Display Enable' status bit (bit 0) in Input Status Register 1 indicates that either a horizontal retrace interval or a vertical retrace interval is in progress (the name 'Display Enable' is misleading for this status bit because the bit does not enable nor disable the graphics system as its name suggests). In the IBM™ EGA graphics system (and the ones that preceded it, including MDA and CGA) it was important to check the status of this bit to ensure that one or the other of the retrace intervals was taking place before accessing the graphics memory. In these earlier systems reading from or writing to graphics memory outside the retrace intervals meant that the CRT controller would be cut off from accessing the graphics memory in order to draw pixels to the display, resulting in either "snow" or a flickering display.

ST00 Input Status Register 0

read-only at I/O Address 3C2h

7	6	5	4	3	2	1	0
Vert Ret Interrupt	Reserved		DAC CRT Sense	Reserved			

7 Vertical Retrace Interrupt

0: Indicates that a vertical retrace interrupt is not pending.

1: Indicates that a vertical retrace interrupt is pending.

Note: This bit does NOT indicate the status of any real hardware interrupt occurring at the onset of vertical retrace. This bit works in conjunction with bit 3 of ST01 and bits 4 and 5 of CR11 to implement a "phantom" interrupt for the sake of compatibility with older software. Early VGA graphics systems (and their predecessors, including the EGA) had the ability to generate a hardware interrupt on IRQ9 whenever a vertical retrace commenced. This was done because in these earlier graphics systems it was important for the host CPU to wait for a vertical retrace interval before accessing the frame buffer. If the host CPU accessed the frame buffer at a time other than the vertical retrace interval, i.e., while data for the active display area was being drawn to the display, then either "snow" on the display or a flickering display would result. Later graphics systems, including this one, do NOT actually generate this interrupt.

6-5 Reserved

These bits return the value of 0 when read.

4 DAC CRT Sense

Indicates the state of the DAC analog output comparators. The comparators can be used to determine whether a CRT is currently attached, and/or whether the CRT is color or monochrome. This is done by blanking the CRT outputs, which causes the color value stored at index 0 in the color lookup table of the RAMDAC to be continuously output to the CRT. Different color values can then be written to the color lookup table at index 0 to set different output levels for the red, green and blue D-to-A converters.

Result	When Testing for Presence of CRT	When Testing for Color or Monochrome CRT
0	No CRT is present.	Monochrome CRT.
1	CRT is present.	Color CRT.

3-0 Reserved

These bits return the value of 0 when read.

ST01 Input Status Register 1

read-only at I/O Address 3BAh/3DAh

7	6	5	4	3	2	1	0
VSYNC Output	Reserved	Video Feedback 1,0		Vertical Retrace	Reserved		Display Enable

7 VSYNC Output

0: The VSYNC output pin is currently inactive.

1: The VSYNC output pin is currently active.

Note: This bit is largely unused by current software.

6 Reserved

This bit returns the value of 0 when read.

5-4 Video Feedback 1, 0

These are diagnostic video bits that are programmable when connected to two of the eight color bits sent to the palette. Bits 4 and 5 of the Color Plane Enable Register (AR12) select which two of the eight possible color bits become connected to these 2 bits of this register. The current software normally does not use these 2 bits. They exist for EGA compatibility.

3 Vertical Retrace

0: Indicates that a vertical retrace interval is not taking place.

1: Indicates that a vertical retrace interval is taking place.

2-1 Reserved

These bits return the value of 0 when read.

0 Display Enable

0: Data for the active display area is being drawn to the display. Neither a horizontal retrace interval nor a vertical retrace interval is currently taking place.

1: Either a horizontal or vertical retrace interval is currently taking place.

FCR Feature Control Register

write at I/O Address 3BAh/3DAh

read at I/O Address 3CAh

7	6	5	4	3	2	1	0
Reserved				VSYNC Control	Reserved		

7-4 Reserved

These bits return the value of 0 when read.

3 VSYNC Control

0: VSYNC output pin simply provides the vertical sync signal.

1: VSYNC output pin provides a signal that is the logical OR of the vertical sync signal and the value of bit 0 of Input Status Register 1 (ST01).

Note: This feature is largely unused by current software -- this bit is provided solely for VGA compatibility.

2-0 Reserved

These bits return the value of 0 when read.

MSR Miscellaneous Output Register

write at I/O Address 3C2h

read at I/O Address 3CCh

7	6	5	4	3	2	1	0
Sync Output Polarity (00)		Page Select (0)	Reserved (0)	Clock Select (00)		RAM Enable (0)	I/O Address (0)

7-6 Sync Output Polarity

Bit 7 controls the polarity of the VSYNC output, while bit 6 performs the same function for the HSYNC output. For both of these bits, a value of 0 sets the corresponding sync output for positive polarity, while a value of 1 chooses negative polarity.

The original VGA standard was created at a time pre-dating the onset of multifrequency displays that examined clock rates or counted pulses to determine resolutions. Therefore, different combinations of positive and negative polarities on the sync outputs were used to set original VGA displays to any one of three modes (depicted in the table below). However, over time, numerous additional resolutions and alternate timings intended to improve upon the original VGA standard came to be widely used. In order to maintain compatibility with the VGA standard, the vast majority of these use HSYNC and VSYNC outputs that are both configured to be of positive polarity since this was the only choice left over as 'reserved' in the original VGA standard.

Bit 7 6	VSYNC Output Polarity	HSYNC Output Polarity	Vertical Resolution Selected
0 0	positive	positive	Not used for standard VGA modes. Often used for extended modes regardless of the number of scanlines.
0 1	positive	negative	For standard VGA modes with 400 scanlines.
1 0	negative	positive	For standard VGA modes with 350 scanlines.
1 1	negative	negative	For standard VGA modes with 480 scanlines.

5 Odd/Even Page Select

0: Selects the lower 64KB page.

1: Selects the upper 64KB page.

Selects between two 64KB pages of frame buffer memory during standard VGA odd/even modes (modes 0h through 5h). Bit 1 of register GR06 can also program this bit in other modes.

4 Reserved

This bit returns the value of 0 when read.

3-2 Clock Select

These two bits select the dot clock.

Bit 3 2	Selected Clock
0 0	CLK0 -- default 25MHz (for standard VGA modes with a horizontal resolution of 320 or 640 pixels.
0 1	CLK1 -- default 28MHz (for standard VGA modes with a horizontal resolution of 360 or 720 pixels.
1 0	CLK2 (normally for all extended modes or at any time a flat panel display is used) (this selection was 'reserved' in the original VGA standard)
1 1	reserved

1 RAM Access Enable

- 0: Disables CPU access to frame buffer.
- 1: Enables CPU access to frame buffer.

0 I/O Address Select

- 0: Sets the I/O address decode for ST01, FCR, and all CR registers to the 3Bx I/O address range (for MDPA emulation).
- 1: Sets the I/O address decode for ST01, FCR, and all CR registers to the 3Dx I/O address range (for CGA emulation).

Chapter 9

CRT Controller Registers

Name	Register Function	Access 3B5/3D5	Index Value 3B4/3D4 (CRX)
CR00	Horizontal Total Register	read/write	00h
CR01	Horizontal Display Enable End Register	read/write	01h
CR02	Horizontal Blanking Start Register	read/write	02h
CR03	Horizontal Blanking End Register	read/write	03h
CR04	Horizontal Sync Start Register	read/write	04h
CR05	Horizontal Sync End Register	read/write	05h
CR06	Vertical Total Register	read/write	06h
CR07	Overflow Register	read/write	07h
CR08	Preset Row Scan Register	read/write	08h
CR09	Maximum Scanline Register	read/write	09h
CR0A	Text Cursor Start Scanline Register	read/write	0Ah
CR0B	Text Cursor End Scanline Register	read/write	0Bh
CR0C	Start Address High Register	read/write	0Ch
CR0D	Start Address Low Register	read/write	0Dh
CR0E	Text Cursor Location High Register	read/write	0Eh
CR0F	Text Cursor Location Low Register	read/write	0Fh
CR10	Vertical Sync Start Register	read/write	10h
CR11	Vertical Sync End Register	read/write	11h
CR12	Vertical Display Enable End Register	read/write	12h
CR13	Offset Register	read/write	13h
CR14	Underline Row Register	read/write	14h
CR15	Vertical Blanking Start Register	read/write	15h
CR16	Vertical Blanking End Register	read/write	16h
CR17	CRT Mode Control Register	read/write	17h
CR18	Line Compare Register	read/write	18h
CR22	Memory Read Latch Data Register	read-only	22h
CR30	Extended Vertical Total Register	read/write	30h
CR31	Extended Vertical Display End Register	read/write	31h
CR32	Extended Vertical Sync Start Register	read/write	32h
CR33	Extended Vertical Blanking Start Register	read/write	33h
CR38	Extended Horizontal Total Register	read/write	38h
CR3C	Extended Horizontal Blanking End Register	read/write	3Ch
CR40	Extended Start Address Register	read/write	40h
CR41	Extended Offset Register	read/write	41h
CR70	Interlace Control Register	read/write	70h
CR71	NTSC/PAL Video Output Control Register	read/write	71h
CR72	NTSC/PAL Horizontal Serration 1 Start Register	read/write	72h
CR73	NTSC/PAL Horizontal Serration 2 Start Register	read/write	73h
CR74	NTSC/PAL Horizontal Pulse Width Register	read/write	74h
CR75	NTSC/PAL Filtering Burst Read Length Register	read/write	75h
CR76	NTSC/PAL Filtering Burst Read Quantity Register	read/write	76h
CR77	NTSC/PAL Filtering Control Register	read/write	77h
CR78	NTSC/PAL Vertical Reduction Register	read/write	78h
CR79	NTSC/PAL Pixel Resolution Fine Adjust Register	read/write	79h

See Note on following page:

Note: The CRT controller registers are accessed by writing the index of the desired register into the CRT Controller Index Register at I/O address 3B4h or 3D4h (depending upon whether the graphics system is configured for MDA or CGA emulation), and then accessing the desired register through the data port for the CRT controller registers located at I/O address 3B5h or 3D5h (again depending upon the choice of MDA or CGA emulation).

CRX CRT Controller Index Register

read/write at I/O address 3B4h/3D4h

This register is cleared to 00h by reset.

7	6	5	4	3	2	1	0
CRT Controller Register Index							

7-0 CRT Controller Register Index

These 8 bits are used to select any one of the CRT controller registers to be accessed via the data port at I/O location 3B5h or 3D5h (depending upon whether the graphics system is configured for MDA or CGA emulation).

CR00 Horizontal Total Register

read/write at I/O address 3B5h/3D5h with index at address 3B4h/3D4h set to 00h

7	6	5	4	3	2	1	0
Horizontal Total							

7-0 Horizontal Total

These bits provide either all 8 bits of an 8-bit value or the least significant 8 bits of a 9-bit value that specifies the total length of a scanline. This includes both the part of the scanline that is within the active display area and the part that is outside of it.

In standard VGA modes, where bit 0 of the I/O Control Register (XR09) is set to 0, the horizontal total is specified with an 8-bit value, 8 bits of which are supplied by this register.

In extended modes, where bit 0 of the I/O Control Register (XR09) is set to 1, the horizontal total is specified with a 9-bit value. The 8 least significant bits of the vertical total are supplied by the 8 bits of this register. The most significant bit is supplied by bit 0 of the Extended Horizontal Total Register (CR38).

This 8-bit or 9-bit value should be programmed to equal the total number of character clocks within the total length of a scanline, minus 5.

Note: For NTSC/PAL output support, CR79 can be used to add a programmable number of pixel clocks (as opposed to character clocks) to the horizontal total, permitting the horizontal total to be specified with greater precision.

CR01 Horizontal Display Enable End Register

read/write at I/O address 3B5h/3D5h with index at 3B4h/3D4h set to 01h

7	6	5	4	3	2	1	0
Horizontal Display Enable End							

7-0 Horizontal Display Enable End

This register is used to specify the end of the part of the scanline that is within the active display area relative to its beginning. In other words, this is the horizontal width of the active display area.

This register should be programmed with a value equal to the number of character clocks that occur within the part of a scanline that is within the active display area minus 1.

CR02 Horizontal Blanking Start Register

read/write at I/O address 3B5h/3D5h with index at address 3B4h/3D4h set to 02h

7	6	5	4	3	2	1	0
Horizontal Blanking Start							

7-0 Horizontal Blanking Start

This register is used to specify the beginning of the horizontal blanking period relative to the beginning of the active display area of a scanline.

This register should be programmed with a value equal to the number of character clocks that occur on a scanline from the beginning of the active display area to the beginning of the horizontal blanking.

CR03 Horizontal Blanking End Register

read/write at I/O address 3B5h/3D5h with index at address 3B4h/3D4h set to 03h

7	6	5	4	3	2	1	0
Reserved	Display Enable Skew Control		Horizontal Blanking End Bits 4-0				

7 Reserved

Values written to this bit are ignored. To maintain consistency with the VGA standard, a value of 1 is returned whenever this bit is read. At one time, this bit was used to enable access to certain light pen registers. At that time, setting this bit to 0 provided this access, but setting this bit to 1 was necessary for normal operation.

6-5 Display Enable Skew Control

Defines the degree to which the start and end of the active display area are delayed along the length of a scanline to compensate for internal pipeline delays.

These 2 bits describe the delay in terms of a number character clocks.

Bit 6 5	Amount of Delay
0 0	no delay
0 1	delayed by 1 character clock
1 0	delayed by 2 character clocks
1 1	delayed by 3 character clocks

4-0 Horizontal Blanking End Bits 4-0

These 5 bits provide the 5 least significant bits of either a 6-bit or 8-bit value that specifies the end of the blanking period relative to its beginning on a single scanline.

In standard VGA modes, where bit 0 of the I/O Control Register (XR09) is set to 0, the horizontal blanking end is specified with a 6-bit value. The 5 least significant bits of the horizontal blanking end are supplied by these 5 bits of this register, and the most significant bits is supplied by bit 7 of the Horizontal Sync End Register (CR05).

In extended modes, where bit 0 of the I/O Control Register (XR09) is set to 1, the horizontal blanking end is specified with an 8-bit value. The 5 least significant bits of the horizontal blanking end are supplied by these 5 bits of this register, the next most significant bit is supplied by bit 7 of the Horizontal Sync End Register (CR05), and the 2 most significant bits are supplied by bits 7 and 6 of the Extended Horizontal Blanking End Register (CR3C).

This 6-bit or 8-bit value should be programmed to be equal to the least significant 6 or 8 bits, respectively, of the result of adding the length of the blanking period in terms of character clocks to the value specified in the Horizontal Blanking Start Register (CR02).

CR04 Horizontal Sync Start Register

read/write at I/O address 3B5h/3D5h with index at address 3B4h/3D4h set to 04h

7	6	5	4	3	2	1	0
Horizontal Sync Start							

7-0 Horizontal Sync Start

This register is used to specify the beginning of the horizontal sync pulse relative to the beginning of the active display area on a scanline.

This register should be set to be equal to the number of character clocks that occur from the beginning of the active display area to the beginning of the horizontal sync pulse on a single scanline.

CR05 Horizontal Sync End Register

read/write at I/O address 3B5h/3D5h with index at address 3B4h/3D4h set to 05h

7	6	5	4	3	2	1	0
Hor Blnk End Bit 5	Horizontal Sync Delay		Horizontal Sync End				

7 Horizontal Blanking End Bit 5

This bit provides either the most significant bit of a 6-bit value or the 3rd most significant bit of an 8-bit value that specifies the end of the horizontal blanking period relative to its beginning.

In standard VGA modes, where bit 0 of the I/O Control Register (XR09) is set to 0, the horizontal blanking end is specified with a 6-bit value. The 5 least significant bits of this value are supplied by bits 4-0 of the Horizontal Blanking End Register (CR03), and the most significant bit is supplied by this bit of this register.

In extended modes, where bit 0 of the I/O Control Register (XR09) is set to 1, the horizontal blanking end is specified with an 8-bit value. The 5 least significant bits of this value are supplied by bits 4-0 of the Horizontal Blanking End Register (CR03), the next most significant bit is supplied by this bit of this register, and the 2 most significant bits are supplied by bits 7 and 6 of the Extended Horizontal Blanking End Register (CR3C).

This 6-bit or 8-bit value should be programmed to be equal to the least significant 6 or 8 bits, respectively, of the result of adding the length of the blanking period in terms of character clocks to the value specified in the Horizontal Blanking Start Register (CR02).

6-5 Horizontal Sync Delay

These bits define the degree to which the start and end of the horizontal sync pulse are delayed to compensate for internal pipeline delays.

These 2 bits describe the delay in terms of a number of character clocks.

Bit 6 5	Amount of Delay
0 0	no delay
0 1	delayed by 1 character clock
1 0	delayed by 2 character clocks
1 1	delayed by 3 character clocks

4-0 Horizontal Sync End

These 5 bits provide the 5 least significant bits of a 6-bit value that specifies the end of the horizontal sync pulse relative to its beginning. In other words, this 6-bit value specifies the width of the horizontal sync pulse. Bit 7 of Horizontal Sync End Register (CR05) supplies the most significant bit.

This 6-bit value should be set to the least significant 6 bits of the result of adding the width of the sync pulse in terms of character clocks to the value specified in the Horizontal Sync Start Register (CR04).

CR06 Vertical Total Register

read/write at I/O address 3B5h/3D5h with index at address 3B4h/3D4h set to 06h

7	6	5	4	3	2	1	0
Vertical Total Bits 7-0							

7-0 Vertical Total Bits

These bits provide the 8 least significant bits of either a 10-bit or 12-bit value that specifies the total number of scanlines. This includes the scanlines both inside and outside of the active display area.

In standard VGA modes, where bit 0 of the I/O Control Register (XR09) is set to 0, the vertical total is specified with a 10-bit value. The 8 least significant bits of the vertical total are supplied by these 8 bits of this register, and the 2 most significant bits are supplied by bits 5 and 0 of the Overflow Register (CR07).

In extended modes, where bit 0 of the I/O Control Register (XR09) is set to 1, the vertical total is specified with a 12-bit value. The 8 least significant bits of the vertical total are supplied by the 8 bits of this register (CR06). The 4 most significant bits are supplied by bits 3-0 of the Extended Vertical Total Register (CR30).

This 10-bit or 12-bit value should be programmed to equal the total number of scanlines minus 2.

CR07 Overflow Register

read/write at I/O address 3B5h/3D5h with index at address 3B4h/3D4h set to 07h

7	6	5	4	3	2	1	0
Vert Sync Start Bit 9	Vert Disp En Bit 9	Vert Total Bit 9	Line Cmp Bit 8	Vert Blink Start Bit 8	Vert Sync Start Bit 8	Vert Disp En Bit 8	Vert Total Bit 8

7 Vertical Sync Start Bit 9

The vertical sync start is a 10-bit or 12-bit value that specifies the beginning of the vertical sync pulse relative to the beginning of the active display area.

In standard VGA modes, where bit 0 of the I/O Control Register (XR09) is set to 0, the vertical sync start is specified with a 10-bit value. The 8 least significant bits of the vertical sync start are supplied by bits 7-0 of the Vertical Sync Start Register (CR10), and the most and second-most significant bits are supplied by bit 7 and bit 2 of this register (CR07), respectively.

In extended modes, where bit 0 of the I/O Control Register (XR09) is set to 1, the vertical display end is specified with a 12-bit value. The 8 least significant bits of the vertical display end are supplied by bits 7-0 of the Vertical Sync Start Register (CR10), and the 4 most significant bits are supplied by bits 3-0 of the Extended Vertical Sync Start Register (CR32) register. In extended modes, neither bit 7 nor bit 2 of this register are used.

This 10-bit or 12-bit value should be programmed to be equal to the number of scanlines from the beginning of the active display area to the start of the vertical sync pulse. Since the active display area always starts on the 0th scanline, this number should be equal to the number of the scanline on which the vertical sync pulse begins.

6 Vertical Display Enable End Bit 9

The vertical display enable end is a 10-bit or 12-bit value that specifies the number of the last scanline within the active display area.

In standard VGA modes, where bit 0 of the I/O Control Register (XR09) is set to 0, the vertical display enable end is specified with a 10-bit value. The 8 least significant bits of the vertical display enable are supplied by bits 7-0 of the Vertical Display Enable End Register (CR12), and the most and second-most significant bits are supplied by bit 6 and bit 1 of this register (CR07), respectively.

In extended modes, where bit 0 of the I/O Control Register (XR09) is set to 1, the vertical display enable end is specified with a 12-bit value. The 8 least significant bits of the vertical display enable are supplied by bits 7-0 of the Vertical Display Enable End Register (CR12), and the 4 most significant bits are supplied by bits 3-0 of the Extended Vertical Display End Enable Register (CR31). In extended modes, neither bit 6 nor bit 1 of this register are used.

This 10-bit or 12-bit value should be programmed to be equal to the number of the last scanline within in the active display area. Since the active display area always starts on the 0th scanline, this number should be equal to the total number of scanlines within the active display area minus 1.

5 Vertical Total Bit 9

The vertical total is a 10-bit or 12-bit value that specifies the total number of scanlines. This includes the scanlines both inside and outside of the active display area.

In standard VGA modes, where bit 0 of the I/O Control Register (XR09) is set to 0, the vertical total is specified with a 10-bit value. The 8 least significant bits of the vertical total are supplied by bits 7-0 of the Vertical Total Register (CR06), and the most and second-most significant bits are supplied by bit 5 and bit 0 of this register (CR07), respectively.

In extended modes, where bit 0 of the I/O Control Register (XR09) is set to 1, the vertical total is specified with a 12-bit value. The 8 least significant bits of the vertical total are supplied by bits 7-0 of the Vertical Total Register (CR06), and the 4 most significant bits are supplied by 3-0 bits of the Extended Vertical Total Register (CR30). In extended modes, neither bit 5 nor bit 0 of this register are used.

This 10-bit or 12-bit value should be programmed to be equal to the total number of scanlines minus 2.

4 Line Compare Bit 8

This bit provides the second most significant bit of a 10-bit value that specifies the scanline at which the memory address counter restarts at the value of 0. Bit 6 of the Maximum Scanline Register (CR09) supplies the most significant bit, and bits 7-0 of the Line Compare Register (CR18) supply the 8 least significant bits.

Normally, this 10-bit value is set to specify a scanline after the last scanline of the active display area. When this 10-bit value is set to specify a scanline within the active display area, it causes that scanline and all subsequent scanlines in the active display area to display video data starting at the very first byte of the frame buffer. The result is what appears to be a screen split into a top and bottom part, with the image in the top part being repeated in the bottom part.

When used in cooperation with the Start Address High Register (CR0C) and the Start Address Low Register (CR0D), it is possible to create a split display, as described earlier, but with the top and bottom parts displaying different data. The top part will display whatever data exists in the frame buffer starting at the address specified in the two start address registers (CR0C and CR0D), while the bottom part will display whatever data exists in the frame buffer starting at the first byte of the frame buffer.

3 Vertical Blanking Start Bit 8

The vertical blanking start is a 10-bit or 12-bit value that specifies the beginning of the vertical blanking period relative to the beginning of the active display area.

In standard VGA modes, where bit 0 of the I/O Control Register (XR09) is set to 0, the vertical blanking start is specified with a 10-bit value. The 8 least significant bits of the vertical blanking start are supplied by bits 7-0 of the Vertical Blanking Start Register (CR15), and the most and second-most significant bits are supplied by bit 5 of the Maximum Scanline Register (CR09) and bit 3 of this register (CR07), respectively.

In extended modes, where bit 0 of the I/O Control Register (XR09) is set to 1, the vertical blanking start is specified with a 12-bit value. The 8 least significant bits of the vertical blanking start are supplied by bits 7-0 of the Vertical Blanking Start Register (CR15), and the 4 most significant bits are supplied by bits 3-0 of the Extended Vertical Blanking Start Register (CR33). In extended modes, neither bit 3 of CR07 nor bit 5 of the Maximum Scanline Register (CR09) are used.

This 10-bit or 12-bit value should be programmed to be equal to the number of scanlines from the beginning of the active display area to the beginning of the blanking period. Since the active display area always starts on the 0th scanline, this number should be equal to the number of the scanline on which the vertical blanking period begins.

2 Vertical Sync Start Bit 8

The vertical sync start is a 10-bit or 12-bit value that specifies the beginning of the vertical sync pulse relative to the beginning of the active display area.

In standard VGA modes, where bit 0 of the I/O Control Register (XR09) is set to 0, the vertical sync start is specified with a 10-bit value. The 8 least significant bits of the vertical sync start are supplied by bits 7-0 of the Vertical Sync Start Register (CR10), and the most and second-most significant bits are supplied by bit 7 and bit 2 of this register (CR07), respectively.

In extended modes, where bit 0 of the I/O Control Register (XR09) is set to 1, the vertical display end is specified with a 12-bit value. The 8 least significant bits of the vertical display are supplied by bits 7-0 of the Vertical Sync Start Register (CR10), and the 4 most significant bits are supplied by bits 3-0 of the Extended Vertical Sync Start Register (CR32) register. In extended modes, neither bit 7 nor bit 2 of this register (CR07) are used.

This 10-bit or 12-bit value should be programmed to be equal to the number of scanlines from the beginning of the active display area to the start of the vertical sync pulse. Since the active display area always starts on the 0th scanline, this number should be equal to the number of the scanline on which the vertical sync pulse begins.

1 Vertical Display Enable End Bit 8

The vertical display enable end is a 10-bit or 12-bit value that specifies the number of the last scanline within the active display area.

In standard VGA modes, where bit 0 of the I/O Control Register (XR09) is set to 0, the vertical display enable end is specified with a 10-bit value. The 8 least significant bits of the vertical display enable are supplied by bits 7-0 of the Vertical Display Enable End Register (CR12), and the most and second-most significant bits are supplied by bit 6 and bit 1 of this register (CR07), respectively.

In extended modes, where bit 0 of the I/O Control Register (XR09) is set to 1, the vertical display enable end is specified with a 12-bit value. The 8 least significant bits of the vertical display enable are supplied by bits 7-0 of the Vertical Display Enable End Register (CR12), and the 4 most significant bits are supplied by bits 3-0 of the Extended Vertical Display End Enable Register (CR31). In extended modes, neither bit 6 nor bit 1 of this register (CR07) are used.

This 10-bit or 12-bit value should be programmed to be equal to the number of the last scanline within in the active display area. Since the active display area always starts on the 0th scanline, this number should be equal to the total number of scanlines within the active display area minus 1.

0 Vertical Total Bit 8

The vertical total is a 10-bit or 12-bit value that specifies the total number of scanlines. This includes the scanlines both inside and outside of the active display area.

In standard VGA modes, where bit 0 of the I/O Control Register (XR09) is set to 0, the vertical total is specified with a 10-bit value. The 8 least significant bits of the vertical total are supplied by bits 7-0 of the Vertical Total Register (CR06), and the most and second-most significant bits are supplied by bit 5 and bit 0 of this register (CR07), respectively.

In extended modes, where bit 0 of the I/O Control Register (XR09) is set to 1, the vertical total is specified with a 12-bit value. The 8 least significant bits of the vertical total are supplied by bits 7-0 of the Vertical Total Register (CR06), and the 4 most significant bits are supplied by 3-0 bits of the Extended Vertical Total Register (CR30). In extended modes, neither bit 5 nor bit 0 of this register (CR07) are used.

This 10-bit or 12-bit value should be programmed to be equal to the total number of scanlines minus 2.

CR08 Preset Row Scan Register

read/write at I/O address 3B5h/3D5h with index at address 3B4h/3D4h set to 08h

7	6	5	4	3	2	1	0
Reserved	Left Hor Pixel Shift		Starting Row Scan Count				

7 Reserved

6-5 Leftward Horizontal Pixel Shift

Bits 6 and 5 of this register hold a 2-bit value that selects number of bytes (up to 3) by which the image is shifted horizontally to the left on the screen. This function is available in both text and graphics modes.

In text modes with a 9-pixel wide character box, the image can be shifted up to 27 pixels to the left, in increments of 9 pixels.

In text modes with an 8-pixel wide character box, and in all standard VGA graphics modes, the image can be shifted up to 24 pixels to the left in increments of 8 pixels.

The image can be shifted still further, in increments of individual pixels, through the use of bits 3-0 of the Horizontal Pixel Panning Register (AR13).

Number of Pixels Shifted		
Bit 6 5	9-Pixel Text	8-Pixel Text & Graphics
0 0	0	0
0 1	9	8
1 0	18	16
1 1	27	24

Note: In the VGA standard this is called the 'Byte Panning' bit.

4-0 Starting Row Scan Count

These 5 bits specify which horizontal line of pixels within the character boxes of the characters used on the top-most row of text on the display will be used as the top-most scanline. The horizontal lines of pixels of a character box are numbered from top to bottom, with the top-most line of pixels being number 0. If a horizontal line of these character boxes other than the top-most line is specified, then the horizontal lines of the character box above the specified line of the character box will not be displayed as part of the top-most row of text characters on the display. Normally the value specified by these 5 bits should be 0, so that all of the horizontal lines of pixels within these character boxes will be displayed in the top-most row of text, ensuring that the characters in the top-most row of text do not look as though they have been cut off at the top.

CR09 Maximum Scanline Register

read/write at I/O address 3B5h/3D5h with index at address 3B4h/3D4h set to 09h

7	6	5	4	3	2	1	0
Double Scanning	Line Cmp Bit 9	Vert Blnk Start Bit 9	Maximum Scanline				

7 Double Scanning

0: Disables double scanning. The clock to the row scan counter is equal to the horizontal scan rate. This is the normal setting for many of the standard VGA modes and all of the extended modes.

1: Enables double scanning. The clock to the row scan counter is divided by 2. This is normally used to allow CGA-compatible modes that have only 200 scanlines of active video data to be displayed as 400 scanlines (each scanline is displayed twice).

6 Line Compare Bit 9

This bit provides the most significant bit of a 10-bit value that specifies the scanline at which the memory address counter restarts at the value of 0. Bit 4 of the Overflow Register (CR07) supplies the second most significant bit and bits 7-0 of the Line Compare Register (CR18) supply the 8 least significant bits.

Normally, this 10-bit value is set to specify a scanline after the last scanline of the active display area. When this 10-bit value is set to specify a scanline within the active display area, it causes that scanline and all subsequent scanlines in the active display area to display video data starting at the very first byte of the frame buffer. The result is what appears to be a screen split into a top and bottom part, with the image in the top part being repeated in the bottom part.

When used in cooperation with the Start Address High Register (CR0C) and the Start Address Low Register (CR0D), it is possible to create a split display but with the top and bottom parts displaying different data, as described earlier. The top part will display whatever data exists in the frame buffer starting at the address specified in the two start address registers (CR0C and CR0D) while the bottom part will display whatever data exists in the frame buffer starting at the first byte of the frame buffer.

5 Vertical Blanking Start Bit 9

The vertical blanking start is a 10-bit or 12-bit value that specifies the beginning of the vertical blanking period relative to the beginning of the active display area.

In standard VGA modes, where bit 0 of the I/O Control Register (XR09) is set to 0, the vertical blanking start is specified with a 10-bit value. The 8 least significant bits of the vertical blanking start are supplied by bits 7-0 of the Vertical Blanking Start Register (CR15) and the most and second-most significant bits are supplied by bit 5 of this register (CR09) and bit 3 of the Overflow Register (CR07), respectively.

In extended modes, where bit 0 of the I/O Control Register (XR09) is set to 1, the vertical blanking start is specified with a 12-bit value. The 8 least significant bits of this value are supplied by bits 7-0 of the Vertical Blanking Start Register (CR15), and the 4 most significant bits are supplied by bits 3-0 of the Extended Vertical Blanking Start Register (CR33). In extended modes, neither bit 5 of CR09 nor bit 3 of the Overflow Register (CR07) are used.

This 10-bit or 12-bit value should be programmed to be equal to the number of scanline from the beginning of the active display area to the beginning of the blanking period. Since the active display area always starts on the 0th scanline, this number should be equal to the number of the scanline on which the vertical blanking period begins.

4-0 Starting Row Scan Count

These bits provide all 5 bits of a 5-bit value that specifies the number of scanlines in a horizontal row of text.

This value should be programmed to be equal to the number of scanlines in a Horizontal row of text, minus 1.

CR0A Text Cursor Start Register

read/write at I/O address 3B5h/3D5h with index at address 3B4h/3D4h set to 0Ah

7	6	5	4	3	2	1	0
Reserved		Text Cursor Off	Text Cursor Start				

This cursor is the text cursor that is part of the VGA standard and should not be confused with the hardware cursor and popup (cursor 1 and cursor 2), which are intended to be used in graphics modes. This register is entirely ignored in graphics modes.

7-6 Reserved

5 Text Cursor Off

- 0: Enables the text cursor.
- 1: Disables the text cursor.

4-0 Text Cursor Start

These 5 bits specify which horizontal line of pixels within a character box is to be used to display the first horizontal line of the cursor in text mode. The horizontal lines of pixels within a character box are numbered from top to bottom, with the top-most line being number 0. The value specified by these 5 bits should be the number of the first horizontal line of pixels on which the cursor is to be shown.

CR0B Text Cursor End Register

read/write at I/O address 3B5h/3D5h with index at address 3B4h/3D4h set to 0Bh

7	6	5	4	3	2	1	0
Reserved	Text Cursor Skew		Text Cursor End				

This cursor is the text cursor that is part of the VGA standard and should not be confused with the hardware cursor and popup (cursor 1 and cursor 2), which are intended to be used in graphics modes. This register is entirely ignored in graphics modes.

7 Reserved

6-5 Text Cursor Skew

Specifies the degree to which the start and end of each horizontal line of pixels making up the cursor is delayed to compensate for internal pipeline delays.

These 2 bits describe the delay in terms of a number of character clocks.

Bits 6 5	Amount of Delay
0 0	no delay
0 1	delayed by 1 character clock
1 0	delayed by 2 character clocks
1 1	delayed by 3 character clocks

4-0 Text Cursor End

These 5 bits specify which horizontal line of pixels within a character box is to be used to display the last horizontal line of the cursor in text mode. The horizontal lines of pixels within a character box are numbered from top to bottom, with the top-most line being number 0. The value specified by these 5 bits should be the number of the last horizontal line of pixels on which the cursor is to be shown.

CR0C Start Address High Register

read/write at I/O address 3B5h/3D5h with index at address 3B4h/3D4h set to 0Ch

7	6	5	4	3	2	1	0
Start Address Bits 15-8							

7-0 Start Address Bits 15-8

This register provides bits 15 through 8 of either a 16-bit or 20-bit value that specifies the memory address offset from the beginning of the frame buffer at which the data to be shown in the active display area begins.

In standard VGA modes, where bit 0 of the I/O Control Register (XR09) is set to 0, the start address is specified with a 16-bit value. The eight bits of this register provide the eight most significant bits of this value, while the eight bits of the Start Address Low Register (CR0D) provide the eight least significant bits.

In extended modes, where bit 0 of the I/O Control Register (XR09) is set to 1, the start address is specified with a 20-bit value. The four most significant bits are provided by bits 3-0 of the Extended Start Address Register (CR40), bits 15 through 8 of this value are provided by this register and the eight least significant bits are provided by the Start Address Low Register (CR0D). Note that in extended modes, these 20 bits are double-buffered and synchronized to VSYNC to ensure that changes occurring on the screen as a result of changes in the start address always have a smooth or instantaneous appearance. To change the start address in extended modes, all three registers must be set for the new value, and then bit 7 of CR40 must be set to 1. When this is done the hardware will update the start address on the next VSYNC. When this update has been performed, the hardware will set bit 7 of CR40 back to 0.

CR0D Start Address Low Register

read/write at I/O address 3B5h/3D5h with index at address 3B4h/3D4h set to 0Dh

7	6	5	4	3	2	1	0
Start Address Bits 7-0							

7-0 Start Address Bits 7-0

This register provides the eight least significant bits of either a 16-bit or 20-bit value that specifies the memory address offset from the beginning of the frame buffer at which the data to be shown in the active display area begins.

In standard VGA modes, where bit 0 of the I/O Control Register (XR09) is set to 0, the start address is specified with a 16-bit value. The eight bits of the Start Address High Register (CR0C) provide the eight most significant bits of this value, while the eight bits of this register provide the eight least significant bits.

In extended modes, where bit 0 of the I/O Control Register (XR09) is set to 1, the start address is specified with a 20-bit value. The four most significant bits are provided by bits 3-0 of the Extended Start Address Register (CR40), bits 15 through 8 of this value are provided by the Start Address High Register (CR0C), and the eight least significant bits are provided by this register. Note that in extended modes, these 20 bits are double-buffered and synchronized to VSYNC to ensure that changes occurring on the screen as a result of changes in the start address always have a smooth or instantaneous appearance. To change the start address in extended modes, all three registers must be set for the new value, and then bit 7 of CR40 must be set to 1. When this is done the hardware will update the start address on the next VSYNC. When this update has been performed, the hardware will set bit 7 of CR40 back to 0.

CR0E Text Cursor Location High Register

read/write at I/O address 3B5h/3D5h with index at address 3B4h/3D4h set to 0Eh

7	6	5	4	3	2	1	0
Text Cursor Location Bits 15-8							

This cursor is the text cursor that is part of the VGA standard and should not be confused with the hardware cursor and popup (cursor 1 and cursor 2), which are intended to be used in graphics modes. This register is entirely ignored in graphics modes.

7-0 Text Cursor Location Bits 15-8

This register provides the 8 most significant bits of a 16-bit value that specifies the address offset from the beginning of the frame buffer at which the text cursor is located. Bit 7-0 of the Text Cursor Location Low Register (CR0F) provide the 8 least significant bits.

CR0F Text Cursor Location Low Register

read/write at I/O address 3B5h/3D5h with index at address 3B4h/3D4h set to 0Fh

7	6	5	4	3	2	1	0
Text Cursor Location Bits 7-0							

This cursor is the text cursor that is part of the VGA standard and should not be confused with the hardware cursor and popup (cursor 1 and cursor 2), which are intended to be used in graphics modes. This register is entirely ignored in graphics modes.

7-0 Text Cursor Location Bits 7-0

This register provides the 8 least significant bits of a 16-bit value that specifies the address offset from the beginning of the frame buffer at which the text cursor is located. Bits 7-0 of the Text Cursor Location High Register (CR0E) provide the 8 most significant bits.

CR10 Vertical Sync Start Register

read/write at I/O address 3B5h/3D5h with index at address 3B4h/3D4h set to 10h

7	6	5	4	3	2	1	0
Vertical Sync Start Bits 7-0							

7-0 Vertical Sync Start Bits 7-0

This register provides the 8 least significant bits of either a 10-bit or 12-bit value that specifies the beginning of the vertical sync pulse relative to the beginning of the active display area of a screen.

In standard VGA modes, where bit 0 of the I/O Control Register (XR09) is set to 0, this value is described in 10 bits with bits 7 and 2 of the Overflow Register (CR07) supplying the 2 most significant bits.

In extended modes, where bit 0 of the I/O Control Register (XR09) is set to 1, this value is described in 12 bits with bits 3-0 of the Extended Vertical Sync Start Register (CR32) supplying the 4 most significant bits.

This 10-bit or 12-bit value should equal the vertical sync start in terms of the number of scanlines from the beginning of the active display area to the beginning of the vertical sync pulse. Since the active display area always starts on the 0th scanline, this number should be equal to the number of the scanline on which the vertical sync pulse begins.

CR11 Vertical Sync End Register

read/write at I/O address 3B5h/3D5h with index at address 3B4h/3D4h set to 11h

7	6	5	4	3	2	1	0
Protect Regs 0-7	Reserved	Vert Int Enable	Vert Int Clear	Vertical Sync End			

7 Protect Registers 0-7

- 0: Enable writes to registers CR00-CR07.
- 1: Disable writes to registers CR00-CR07.

Note: The ability to write to bit 4 of the Overflow Register (CR07) is not affected by this bit. Bit 4 of the Overflow Register is always writable.

6 Reserved

Writes to this bit are ignored. In the VGA standard, this bit was used to switch between 3 and 5 frame buffer refresh cycles during the time required to draw each horizontal line.

5 Vertical Interrupt Enable

- 0: Enable the generation of an interrupt at the beginning of each vertical retrace period.
- 1: Disable the generation of an interrupt at the beginning of each vertical retrace period.

Note: The hardware does not actually provide an interrupt signal which would be connected to an input of the system's interrupt controller. Bit 7 of Input Status Register 0 (ST00) indicates the status of the vertical retrace interrupt, and can be polled by software to determine if a vertical retrace interrupt has taken place. Bit 4 of this register can be used to clear a pending vertical retrace interrupt.

4 Vertical Interrupt Clear

Setting this bit to 0 clears a pending vertical retrace interrupt. This bit must be set back to 1 to enable the generation of another vertical retrace interrupt.

Note: The hardware does not actually provide an interrupt signal which would be connected to an input of the system's interrupt controller. Bit 7 of Input Status Register 0 (ST00) indicates the status of the vertical retrace interrupt, and can be polled by software to determine if a vertical retrace interrupt has taken place. Bit 5 of this register can be used to enable or disable the generation of vertical retrace interrupts.

3-0 Vertical Sync End

These 4 bits provide a 4-bit value that specifies the end of the vertical sync pulse relative to its beginning.

This 4-bit value should be set to the least significant 4 bits of the result of adding the length of the vertical sync pulse in terms of the number of scanlines that occur within the length of the vertical sync pulse to the value that specifies the beginning of the vertical sync pulse. See the description of the Vertical Sync Start Register (CR10) for more details.

CR12 Vertical Display Enable End Register

read/write at I/O address 3B5h/3D5h with index at address 3B4h/3D4h set to 12h

7	6	5	4	3	2	1	0
Vertical Display Enable End Bits 7-0							

7-0 Vertical Display Enable End Bits 7-0

This register provides the 8 least significant bits of either a 10-bit or 12-bit value that specifies the number of the last scanline within the active display area.

In standard VGA modes, where bit 0 of the I/O Control Register (XR09) is set to 0, this value is described in 10 bits with bits 6 and 1 of the Overflow Register (CR07) supplying the 2 most significant bits.

In extended modes, where bit 0 of the I/O Control Register (XR09) is set to 1, this value is described in 12 bits with bits 3-0 of the Extended Vertical Display Enable End Register (CR31) supplying the 4 most significant bits.

This 10-bit or 12-bit value should be programmed to be equal to the number of the last scanline within in the active display area. Since the active display area always starts on the 0th scanline, this number should be equal to the total number of scanlines within the active display area, minus 1.

CR13 Offset Register

read/write at I/O address 3B5h/3D5h with index at address 3B4h/3D4h set to 13h

7	6	5	4	3	2	1	0
Offset Bits 7-0							

7-0 Offset Bits 7-0

This register provides either all 8 bits of an 8-bit value or the 8 least significant bits of a 12-bit value that specifies the number of words or doublewords of frame buffer memory occupied by each horizontal row of characters. Whether this value is interpreted as the number of words or doublewords is determined by the settings of the bits in the Clocking Mode Register (SR01).

In standard VGA modes, where bit 0 of the I/O Control Register (XR09) is set to 0, the offset is described with an 8-bit value, with all the bits provided by this register (CR13).

In extended modes, where bit 0 of the I/O Control Register (XR09) is set to 1, the offset is described with a 12-bit value. The four most significant bits of this value are provided by bits 3-0 of the Extended Offset Register (CR41), and the eight least significant bits are provided by this register (CR13).

This 8-bit or 12-bit value should be programmed to be equal to either the number of words or doublewords (depending on the setting of the bits in the Clocking Mode Register, SR01) of frame buffer memory that is occupied by each horizontal row of characters.

CR14 Underline Location Register

read/write at I/O address 3B5h/3D5h with index at address 3B4h/3D4h set to 14h

7	6	5	4	3	2	1	0
Reserved	Dword Mode	Count By 4	Underline Location				

7 Reserved

6 Doubleword Mode

0: Frame buffer addresses are interpreted by the frame buffer address decoder as being either byte addresses or word addresses, depending upon the setting of bit 6 of the CRT Mode Control Register (CR17).

1: Frame buffer addresses are interpreted by the frame buffer address decoder as being doubleword addresses regardless of the setting of bit 6 of the CRT Mode Control Register (CR17).

Note: This bit is used in conjunction with bits 6 and 5 of the CRT Mode Control Register (CR17) to select how frame buffer addresses from the CPU are interpreted by the frame buffer address decoder as shown below:

CR14 Bit 6	CR17 Bit 6	Addressing Mode
0	0	Word Mode
0	1	Byte Mode
1	0	Doubleword Mode
1	1	Doubleword Mode

5 Count By 4

0: The memory address counter is incremented either every character clock or every other character clock, depending upon the setting of bit 3 of the CRT Mode Control Register.

1: The memory address counter is incremented either every 4 character clocks or every 2 character clocks, depending upon the setting of bit 3 of the CRT Mode Control Register.

Note: This bit is used in conjunction with bit 3 of the CRT Mode Control Register (CR17) to select the number of character clocks are required to cause the memory address counter to be incremented as shown, below:

CR14 Bit 5	CR17 Bit 3	Address Incrementing Interval
0	0	every character clock
0	1	every 2 character clocks
1	0	every 4 character clocks
1	1	every 2 character clocks

4-0 Underline Location

These 5 bits specify which horizontal line of pixels in a character box is to be used to display a character underline in text mode. The horizontal lines of pixels within a character box are numbered from top to bottom, with the top-most line being number 0. The value specified by these 5 bits should be the number of the horizontal line on which the character underline mark is to be shown.

CR15 Vertical Blanking Start Register

read/write at I/O address 3B5h/3D5h with index at address 3B4h/3D4h set to 15h

7	6	5	4	3	2	1	0
Vertical Blanking Start Bits 7-0							

7-0 Vertical Blanking Start Bits 7-0

This register provides the 8 least significant bits of either a 10-bit or 12-bit value that specifies the beginning of the vertical blanking period relative to the beginning of the active display area of the screen. Whether this value is described in 10 or 12 bits depends on the setting of bit 0 of the I/O Control Register (XR09).

In standard VGA modes, where bit 0 of the I/O Control Register (XR09) is set to 0, the vertical blanking start is specified with a 10-bit value. The most and second-most significant bits of this value are supplied by bit 5 of the Maximum Scanline Register (CR09) and bit 3 of the Overflow Register (CR07), respectively.

In extended modes, where bit 0 of the I/O Control Register (XR09) is set to 1, the vertical blanking start is specified with a 12-bit value. The 4 most significant bits of this value are supplied by bits 3-0 of the Extended Vertical Blanking Start Register (CR33).

This 10-bit or 12-bit value should be programmed to be equal to the number of scanlines from the beginning of the active display area to the beginning of the vertical blanking period. Since the active display area always starts on the 0th scanline, this number should be equal to the number of the scanline on which vertical blanking begins, minus one.

CR16 Vertical Blanking End Register

read/write at I/O address 3B5h/3D5h with index at address 3B4h/3D4h set to 16h

7	6	5	4	3	2	1	0
Vertical Blanking End Bits 7-0							

7-0 Vertical Blanking End Bits 7-0

This register provides a 8-bit value that specifies the end of the vertical blanking period relative to its beginning.

This 8-bit value should be set equal to the least significant 8 bits of the result of adding the length of the vertical blanking period in terms of the number of scanlines that occur within the length of the vertical blanking period to the value that specifies the beginning of the vertical blanking period (see the description of the Vertical Blanking Start Register for details).

CR17 CRT Mode Control

read/write at I/O address 3B5h/3D5h with index at address 3B4h/3D4h set to 17h

7	6	5	4	3	2	1	0
CRT Ctrl Reset	Word or Byte Mode	Address Wrap	Reserved	Count By 2	Horizontal Retrace Sel	Select Row Scan Cntr	Compat Mode Supp.

7 CRT Controller Reset

0: Forces horizontal and vertical sync signals to be inactive. No other registers or outputs are affected.

1: Permits normal operation.

6 Word Mode or Byte Mode

0: The memory address counter's output bits are shifted by 1 bit position before being passed on to the frame buffer address decoder such that they are made into word-aligned addresses when bit 6 of the Underline Location Register (CR17) is set to 0.

1: The memory address counter's output bits remain unshifted before being passed on to the frame buffer address decoder such that they remain byte-aligned addresses when bit 6 of the Underline Location Register (CR17) is set to 0.

Note: This bit is used in conjunction with bits 6 and 5 of the CRT Mode Control Register (CR17) to control how frame buffer addresses from the memory address counter are interpreted by the frame buffer address decoder as shown below:

CR14 Bit 6	CR17 Bit 6	Addressing Mode
0	0	Word Mode -- addresses from the memory address counter are shifted once to become word-aligned
0	1	Byte Mode -- addresses from the memory address counter are not shifted
1	0	Doubleword Mode -- addresses from the memory address counter are shifted twice to become doubleword-aligned
1	1	Doubleword Mode -- addresses from the memory address counter are shifted twice to become doubleword-aligned

See the note at the end of this register description.

5 Address Wrap

0: Wrap frame buffer address at 16KB. This is used in CGA-compatible modes.

1: No wrapping of frame buffer addresses.

Note: This bit is only effective when word mode is made active by setting bit 6 in both the Underline Location Register and this register to 0.

See the note at the end of this register description.

4 Reserved

3 Count By 2

- 0: The memory address counter is incremented either every character clock or every 4 character clocks, depending upon the setting of bit 5 of the Underline Location Register.
 1: The memory address counter is incremented either every other clock.

This bit is used in conjunction with bit 5 of the Underline Location Register (CR14) to select the number of character clocks required to cause the memory address counter to be incremented as shown, below:

CR14 Bit 5	CR17 Bit 3	Address Incrementing Interval
0	0	every character clock
0	1	every 2 character clocks
1	0	every 4 character clocks
1	1	every 2 character clocks

2 Horizontal Retrace Select

This bit provides a method to effectively double the vertical resolution by allowing the vertical timing counter to be clocked by the horizontal retrace clock divided by 2 (usually, it would be undivided).

- 0: The vertical timing counter is clocked by the horizontal retrace clock.
 1: The vertical timing counter is clocked by the horizontal retrace clock divided by 2.

1 Select Row Scan Counter

0: A substitution takes place, whereby bit 14 of the 16-bit memory address generated by the memory address counter (after the stage at which these 16 bits may have already been shifted to accommodate word or doubleword addressing) is replaced with bit 1 of the row scan counter at a stage just before this address is presented to the frame buffer address decoder.

- 1: No substitution takes place.

See the note at the end of this register description for an overview of the interactions between this and other bits.

0 Compatibility Mode Support

0: A substitution takes place, whereby bit 13 of the 16-bit memory address generated by the memory address counter (after the stage at which these 16 bits may have already been shifted to accommodate word or doubleword addressing) is replaced with bit 0 of the row scan counter at a stage just before this address is presented to the frame buffer address decoder.

- 1: No substitution takes place.

See the note at the end of this register description for an overview of the interactions between this and other bits.

Note: The two tables that follow show the possible ways in which the address bits from the memory address counter can be shifted and/or reorganized before being presented to the frame buffer address decoder. First, the address bits generated by the memory address counter (MAOut0 to MAOut15) are reorganized, if needed, to accommodate byte, word, or doubleword modes. The resulting reorganized outputs (Reorg0 to Reorg15) may then also be further manipulated with the substitution of bits from the row scan counter (RSOut0 and RSOut1) before finally being presented to the input bits of the frame buffer address decoder (FBIn15-FBIn0).

Bits Generated by the Memory Address Counter (MAOut0 to MAOut15)						Resulting Reorganized Bits	
Byte Mode CR14 bit 6=0 CR17 bit 6=1 CR17 bit 5=X	Word Mode CR14 bit 6=0 CR17 bit 6=0 CR17 bit 5=1	Word Mode CR14 bit 6=0 CR17 bit 6=0 CR17 bit 5=0	Word Mode CR14 bit 6=0 CR17 bit 6=0 CR17 bit 5=0	Doubleword Mode CR14 bit 6=1 CR17 bit 6=X CR17 bit 5=X			
MAOut0	OR	MAOut15	OR	MAOut13	OR	MAOut12	Reorg0
MAOut1		MAOut0		MAOut0		MAOut13	Reorg1
MAOut2		MAOut1		MAOut1		MAOut0	Reorg2
MAOut3		MAOut2		MAOut2		MAOut1	Reorg3
MAOut4		MAOut3		MAOut3		MAOut2	Reorg4
MAOut5		MAOut4		MAOut4		MAOut3	Reorg5
MAOut6		MAOut5		MAOut5		MAOut4	Reorg6
MAOut7		MAOut6		MAOut6		MAOut5	Reorg7
MAOut8		MAOut7		MAOut7		MAOut6	Reorg8
MAOut9		MAOut8		MAOut8		MAOut7	Reorg9
MAOut10		MAOut9		MAOut9		MAOut8	Reorg10
MAOut11		MAOut10		MAOut10		MAOut9	Reorg11
MAOut12		MAOut11		MAOut11		MAOut10	Reorg12
MAOut13		MAOut12		MAOut12		MAOut11	Reorg13
MAOut14		MAOut13		MAOut13		MAOut12	Reorg14
MAOut15		MAOut14		MAOut14		MAOut13	Reorg15

CR17 bit 1=1 CR17 bit 0=1	CR17 bit 1=1 CR17 bit 0=0	CR17 bit 1=0 CR17 bit 0=1	CR17 bit 1=0 CR17 bit 0=0	Bits Sent to the Frame Buffer Address Decoder		
Reorg0	OR	Reorg0	OR	Reorg0	FBIn0	
Reorg1		Reorg1		Reorg1	Reorg1	FBIn1
Reorg2		Reorg2		Reorg2	Reorg2	FBIn2
Reorg3		Reorg3		Reorg3	Reorg3	FBIn3
Reorg4		Reorg4		Reorg4	Reorg4	FBIn4
Reorg5		Reorg5		Reorg5	Reorg5	FBIn5
Reorg6		Reorg6		Reorg6	Reorg6	FBIn6
Reorg7		Reorg7		Reorg7	Reorg7	FBIn7
Reorg8		Reorg8		Reorg8	Reorg8	FBIn8
Reorg9		Reorg9		Reorg9	Reorg9	FBIn9
Reorg10		Reorg10		Reorg10	Reorg10	FBIn10
Reorg11		Reorg11		Reorg11	Reorg11	FBIn11
Reorg12		Reorg12		Reorg12	Reorg12	FBIn12
Reorg13		RSOut0		Reorg13	RSOut0	FBIn13
Reorg14		Reorg14		RSOut1	RSOut1	FBIn14
Reorg15		Reorg15		Reorg15	Reorg15	FBIn15

CR18 Line Compare Register

read/write at I/O address 3B5h/3D5h with index at address 3B4h/3D4h set to 18h

7	6	5	4	3	2	1	0
Line Compare Bits 7-0							

7-0 Line Compare Bits 7-0

This register provides the 8 least significant bits of a 10-bit value that specifies the scanline at which the memory address counter restarts at the value of 0. Bit 6 of the Maximum Scanline Register (CR09) supplies the most significant bit, and bit 4 of the Overflow Register (CR07) supplies the second most significant bit.

Normally, this 10-bit value is set to specify a scanline after the last scanline of the active display area. When this 10-bit value is set to specify a scanline within the active display area, it causes that scanline and all subsequent scanlines in the active display area to display video data starting at the very first byte of the frame buffer. The result is what appears to be a screen split into a top and bottom part, with the image in the top part being repeated in the bottom part.

When used in cooperation with the Start Address High Register (CR0C) and the Start Address Low Register (CR0D), it is possible to create a split display, as described earlier, but with the top and bottom parts displaying different data. The top part will display whatever data exists in the frame buffer starting at the address specified in the two start address registers (CR0C and CR0D), while the bottom part will display whatever data exists in the frame buffer starting at the first byte of the frame buffer.

CR22 Memory Read Latch Data Register

read-only at I/O address 3B5h/3D5h with index at address 3B4h/3D4h set to 22h

7	6	5	4	3	2	1	0
Memory Read Latch Data							

7-0 Memory Read Latch Data

This register provides the value currently stored in 1 of the 4 memory read latches. Bits 1 and 0 of the Read Map Select Register (GR04) select which of the 4 memory read latches may be read using this register.

CR30 Extended Vertical Total Register

read/write at I/O address 3B5h/3D5h with index at address 3B4h/3D4h set to 30h

7	6	5	4	3	2	1	0
Reserved				Vertical Total Bits 11-8			

7-4 Reserved

These bits should always be written with the value of 0.

3-0 Vertical Total Bits 11-8

The vertical total is a 10-bit or 12-bit value that specifies the total number of scanlines. This includes the scanlines both inside and outside of the active display area.

In standard VGA modes, where bit 0 of the I/O Control Register (XR09) is set to 0, the vertical total is specified with a 10-bit value. The 8 least significant bits of the vertical total are supplied by bits 7-0 of the Vertical Total Register (CR06), and the 2 most significant bits are supplied by bits 5 and 0 of the Overflow Register (CR07). In standard VGA modes, these bits 3-0 of this register (CR30) are not used.

In extended modes, where bit 0 of the I/O Control Register (XR09) is set to 1, the vertical total is specified with a 12-bit value. The 8 least significant bits of this value are supplied by bits 7-0 of the Vertical Total Register (CR06), and the 4 most significant bits are supplied by bits 3-0 of this register (CR30).

This 10-bit or 12-bit value should be programmed to be equal to the total number of scanlines, minus 2.

CR31 Extended Vertical Display End Register

read/write at I/O address 3B5h/3D5h with index at address 3B4h/3D4h set to 31h

7	6	5	4	3	2	1	0
Reserved				Vertical Display End Bits 11-8			

7-4 Reserved

These bits should always be written with the value of 0.

3-0 Vertical Display End Bits 11-8

The vertical display enable end is a 10-bit or 12-bit value that specifies the number of the last scanline within the active display area.

In standard VGA modes, where bit 0 of the I/O Control Register (XR09) is set to 0, the vertical display enable end is specified with a 10-bit value. The 8 least significant bits of the vertical display enable end are supplied by bits 7-0 of the Vertical Display Enable End Register (CR12), and the 2 most significant bits are supplied by bits 6 and 1 of the Overflow Register (CR07). In standard VGA modes bits 3-0 of CR31 are not used.

In extended modes, where bit 0 of the I/O Control Register (XR09) is set to 1, the vertical display enable end is specified with a 12-bit value. The 8 least significant bits of the vertical display enable end are supplied by bits 7-0 of the Vertical Display Enable End Register (CR12), and the 4 most significant bits are supplied by these 4 bits of this register (CR31).

This 10-bit or 12-bit value should be programmed to be equal to the number of the last scanline within the active display area. Since the active display area always starts on the 0th scanline, this number should be equal to the total number of scanlines within the active display area, minus 1.

CR32 Extended Vertical Sync Start Register

read/write at I/O address 3B5h/3D5h with index at address 3B4h/3D4h set to 32h

7	6	5	4	3	2	1	0
Reserved				Vertical Sync Start Bits 11-8			

7-4 Reserved

These bits should always be written with the value of 0.

3-0 Vertical Sync Start Bits 11-8

The vertical sync start is a 10-bit or 12-bit value that specifies the beginning of the vertical sync pulse relative to the beginning of the active display area.

In standard VGA modes, where bit 0 of the I/O Control Register (XR09) is set to 0, the vertical sync start is specified with a 10-bit value. The 8 least significant bits of the vertical sync start are supplied by bits 7-0 of the Vertical Sync Start Register (CR10), and the 2 most significant bits are supplied by bits 7 and 2 of the Overflow Register (CR07). In standard VGA modes, bits 3-0 of CR32 are not used.

In extended modes, where bit 0 of the I/O Control Register (XR09) is set to 1, the vertical display end is specified with a 12-bit value. The 8 least significant bits of the vertical sync start are supplied by bits 7-0 of the Vertical Sync Start Register (CR10), and the 4 most significant bits are supplied by bits 3-0 of this register (CR32).

This 10-bit or 12-bit value should be programmed to be equal to the number of scanlines from the beginning of the active display area to the start of the vertical sync pulse. Since the active display area always starts on the 0th scanline, this number should be equal to the number of the scanline on which the vertical sync pulse begins.

CR33 Extended Vertical Blanking Start Register

read/write at I/O address 3B5h/3D5h with index at address 3B4h/3D4h set to 33h

7	6	5	4	3	2	1	0
Reserved				Vertical Blanking Start Bits 11-8			

7-4 Reserved

These bits should always be written with the value of 0.

3-0 Vertical Blanking Start Bits 11-8

The vertical blanking start is a 10-bit or 12-bit value that specifies the beginning of the vertical blanking period relative to the beginning of the active display area.

In standard VGA modes, where bit 0 of the I/O Control Register (XR09) is set to 0, the vertical blanking start is specified with a 10-bit value. The 8 least significant bits of the vertical blanking start are supplied by bits 7-0 of the Vertical Blanking Start Register (CR15), and the most and second-most significant bits are supplied by bit 5 of the Maximum Scanline Register (CR09) and bit 3 of the Overflow Register (CR07), respectively. In standard VGA modes, bits 3-0 of this register (CR33) are not used.

In extended modes, where bit 0 of the I/O Control Register (XR09) is set to 1, the vertical blanking start is specified with a 12-bit value. The 8 least significant bits of this value are supplied by bits 7-0 of the Vertical Blanking Start Register (CR15), and the 4 most significant bits are supplied by bits 3-0 of this register (CR33).

This 10-bit or 12-bit value should be programmed to be equal to the number of scan lines from the beginning of the active display area to the beginning of the blanking period. Since the active display area always starts on the 0th scanline, this number should be equal to the number of the scanline on which the vertical blanking period begins.

CR38 Extended Horizontal Total Register

read/write at I/O address 3B5h/3D5h with index at address 3B4h/3D4h set to 38h

7	6	5	4	3	2	1	0
Reserved (0000:000)							Hor Total Bit 8 (0)

7-1 Reserved

These bits should always be written with the value of 0.

0 Horizontal Total Bit 8

The horizontal total is an 8-bit or 9-bit value that specifies the total length of a scanline. This includes both the part of the scanline that is within the active display area and the part that is outside of it.

In standard VGA modes, where bit 0 of the I/O Control Register (XR09) is set to 0, the horizontal total is specified with an 8-bit value. All 8 bits of the horizontal total are supplied by bits 7-0 of the Horizontal Total Register (CR00). In standard VGA modes, this bit is not used.

In extended modes, where bit 0 of the I/O Control Register (XR09) is set to 1, the horizontal total is specified with a 9-bit value. The 8 least significant bits of this value are supplied by bits 7-0 of the Horizontal Total Register (CR00), and the most significant bit is supplied by this bit of this register.

This 8-bit or 9-bit value should be programmed to equal the total number of character clocks within the total length of a scanline minus 5.

Note: For NTSC/PAL output support, CR79 can be used to add a programmable number of pixel clocks (as opposed to character clocks) to the horizontal total, permitting the horizontal total to be specified with greater precision.

CR3C Extended Horizontal Blanking End Register

read/write at I/O address 3B5h/3D5h with index at address 3B4h/3D4h set to 3Ch

7	6	5	4	3	2	1	0
Horizontal Blank End Bits 7 and 6 (00)		Reserved (00:0000)					

7-6 Horizontal Blanking End Bits 7 and 6

The horizontal blanking end is a 6-bit or 8-bit value that specifies the end of the horizontal blanking period relative to its beginning.

In standard VGA modes, where bit 0 of the I/O Control Register (XR09) is set to 0, the horizontal blanking end is specified with a 6-bit value. The 5 least significant bits of this value are supplied by bits 4-0 of the Horizontal Blanking End Register (CR03), and the most significant bit is supplied by bit 7 of the Horizontal Sync End Register (CR05). In standard VGA modes, this bit is not used.

In extended modes, where bit 0 of the I/O Control Register (XR09) is set to 1, the horizontal blanking end is specified with an 8-bit value. The 5 least significant bits of this value are supplied by bits 4-0 of the Horizontal Blanking End Register (CR03), the next most significant bit is supplied by bit 7 of the Horizontal Sync End Register (CR05), and both the most significant and 2nd most significant bits are supplied by bits 7 and 6, respectively, of this register.

This 6-bit or 8-bit value should be programmed to be equal to the least significant 6 or 8 bits, respectively, of the result of adding the length of the blanking period in terms of character clocks to the value specified in the Horizontal Blanking Start Register (CR02).

5-0 Reserved

These bits should always be written with the value of 0.

CR40 Extended Start Address Register

read/write at I/O address 3B5h/3D5h with index at address 3B4h/3D4h set to 40h

7	6	5	4	3	2	1	0
Strt Addr En	Reserved			Start Address Bits 19-16			

7 Extended Mode Start Address Enable

This bit is used only in extended modes, where bit 0 of the I/O Control Register (XR09) is set to 1, to signal the hardware to update the start address. In extended modes, the start address is specified with a 20 bit value. These 20 bits, which are provided by the Start Address Low Register (CR0D), the Start Address High Register (CR0C) and bits 3-0 of this register, are double-buffered and synchronized to VSYNC to ensure that changes occurring on the screen as a result of changes in the start address always have a smooth or instantaneous appearance. To change the start address in extended modes, all three registers must be set for the new value, and then this bit of this register must be set to 1. Only if this is done, will the hardware update the start address on the next VSYNC. When this update has been performed, the hardware will set bit 7 of this register back to 0.

6-4 Reserved

Whenever this register is written to, these bits should be set to 0.

3-0 Start Address Bits 19-16

The start address is a 16-bit or a 20-bit value that specifies the memory address offset from the beginning of the frame buffer at which the data to be shown in the active display area begins.

In standard VGA modes, where bit 0 of the I/O Control Register (XR09) is set to 0, the start address is specified with a 16-bit value. The eight bits of the Start Address High Register (CR0C) provide the eight most significant bits of this value, while the eight bits of the Start Address Low Register (CR0D) provide the eight least significant bits.

In extended modes, where bit 0 of the I/O Control Register (XR09) is set to 1, the start address is specified with a 20-bit value. The four most significant bits are provided by bits 3-0 of this register, bits 15 through 8 of this value are provided by the Start Address High Register (CR0C), and the eight least significant bits are provided by the Start Address Low Register (CR0D). Note that in extended modes, these 20 bits are double-buffered and synchronized to VSYNC to ensure that changes occurring on the screen as a result of changes in the start address always have a smooth or instantaneous appearance. To change the start address in extended modes, all three registers must be set for the new value, and then bit 7 of this register must be set to 1. Only if this is done, will the hardware update the start address on the next VSYNC. When this update has been performed, the hardware will set bit 7 of this register back to 0.

CR41 Extended Offset Register

read/write at I/O address 3B5h/3D5h with index at address 3B4h/3D4h set to 41h

7	6	5	4	3	2	1	0
Reserved				Offset Bits 11-8			

7-4 Reserved

Whenever this register is written to, these bits should be set to 0.

3-0 Offset Bits 11-8

The offset is an 8-bit or 12-bit value describing the number of words or doublewords of frame buffer memory occupied by each horizontal row of characters. Whether this value is interpreted as the number of words or doublewords is determined by the settings of the bits in the Clocking Mode Register (SR01).

In standard VGA modes, where bit 0 of the I/O Control Register (XR09) is set to 0, the offset is described with an 8-bit value, all the bits of which are provided by the Offset Register (CR13).

In extended modes, where bit 0 of the I/O Control Register (XR09) is set to 1, the offset is described with a 12-bit value. The four most significant bits of this value are provided by bits 3-0 of this register, and the eight least significant bits are provided by the Offset Register (CR13).

This 8-bit or 12-bit value should be programmed to be equal to either the number of words or doublewords (depending on the setting of the bits in the Clocking Mode Register, SR01) of frame buffer memory that is occupied by each horizontal row of characters.

CR70 Interlace Control Register

read/write at I/O address 3B5h/3D5h with index at address 3B4h/3D4h set to 70h

7	6	5	4	3	2	1	0
Interlace Enable	CRT Half-Line Value						

7 Interlace Enable

- 0: Selects non-interlaced CRT output. This is the default after reset.
- 1: Selects interlaced CRT output.

6-0 CRT Half-Line Value

When interlaced CRT output has been selected, these 7 bits specify the position along the length of a scan line at which the half-line vertical sync pulse occurs for the odd frame. This half-line vertical sync pulse begins at a position between two horizontal sync pulses on the last scanline, rather than coincident with the beginning of a horizontal sync pulse at the end of a scanline.

CR71 NTSC/PAL Video Output Control Register

read/write at I/O address 3B5h/3D5h with index at address 3B4h/3D4h set to 71h

7	6	5	4	3	2	1	0
NTSC/ PAL Sel	Pedestal Enable	Blanking Delay Ctrl	Composite Sync Character Clk Delay		Composite Sync Pixel Clk Delay		

7 NTSC/PAL Select

- 0: Selects NTSC-formatted video output.
- 1: Selects PAL-formatted video output.

6 Pedestal Enable

- 0: Disables the provision of an additional voltage pedestal on red, green and blue analog output lines during the active video portions of each horizontal line.
- 1: Enables the provision of an additional voltage pedestal on the red, green, and blue analog output lines during the active video portions of each horizontal line.

5 Blanking Delay Control

- 0: Blanking period is not delayed on odd frames.
- 1: Blanking period is delayed by half a scanline on odd frames.

4-3 Composite Sync Character Clock Delay

These 2 bits specify the number of character clocks (from 0 to 3) by which the composite sync may be delayed.

2-0 Composite Sync Pixel Clock Delay

These 3 bits specify the number of pixel clocks (from 0 to 7) by which the composite sync may be delayed.

CR72 NTSC/PAL Horizontal Serration 1 Start Register

read/write at I/O address 3B5h/3D5h with index at address 3B4h/3D4h set to 72h

7	6	5	4	3	2	1	0
Horizontal Serration 1 Start							

7-0 Horizontal Serration 1 Start

These 8 bits specify the start position along the length of a scanline of the first horizontal serration pulse for composite sync generation.

CR73 NTSC/PAL Horizontal Serration 2 Start Register

read/write at I/O address 3B5h/3D5h with index at address 3B4h/3D4h set to 73h

7	6	5	4	3	2	1	0
Horizontal Serration 2 Start							

7-0 Horizontal Serration 2 Start

These 8 bits specify the start position along the length of a scanline of the second horizontal serration pulse for composite sync generation.

CR74 NTSC/PAL Horizontal Pulse Width Register

read/write at I/O address 3B5h/3D5h with index at address 3B4h/3D4h set to 74h

7	6	5	4	3	2	1	0
Reserved		Round Off	NTSC/PAL Horizontal Equalization Pulse Width				

7-6 Reserved

5 NTSC/PAL Horizontal Pulse Width Round Off Control

0: Enables the generation of horizontal equalization pulses with a width that is approximately equal to half the width of the horizontal sync pulse. The actual width is determined using bits 4-0 of this register.

1: Disables the generation of horizontal equalization pulses.

4-0 NTSC/PAL Horizontal Equalization Pulse Width

These 5 bits specify the pulse width of the horizontal equalization pulse used to generate the NTSC/PAL-compliant composite sync. Normally, the width of this horizontal equalization pulse is approximately half the width of the horizontal sync pulse.

These 5 bits should be programmed with a value equal to the actual pulse width, subtracted by 1. The width of the actual equalization pulse can be calculated as follows:

$$\text{equalization pulse width} - 1 = (\text{CR74}[4:0] - \text{CR74}[5]) \div 2$$

CR75 NTSC/PAL Filtering Burst Read Length Register

read/write at I/O address 3B5h/3D5h with index at address 3B4h/3D4h set to 75h

7	6	5	4	3	2	1	0
Reserved (Writable) (xxxx)				Memory Burst Read Length (xxxx)			

7-4 Reserved

These bits should always be written with the value of 0.

3-0 Memory Burst Access Segment Length

The flicker reduction filtering processes are performed on pixel data as it is sequentially read from the frame buffer to be displayed. These filtering processes involve the averaging of current pixel data that is about to be displayed with data for adjacent pixels. Depending upon which filtering processes are selected, accesses to the frame buffer can become non-sequential. To optimize the use of the frame buffer, burst accesses of one or more quadwords are performed to read this data. These 4 bits provide a means of adjusting how many quadwords of pixel data are read from the frame buffer in each burst access.

CR76 NTSC/PAL Filtering Burst Read Quantity Register

read/write at I/O address 3B5h/3D5h with index at address 3B4h/3D4h set to 76h

7	6	5	4	3	2	1	0
Memory Burst Access Segments Per Scanline (xxxx:xxxx)							

7-0 Memory Burst Access Segments Per Scanline

These 8 bits specify the number of burst reads required to supply both current pixel data and pixel data from adjacent pixels for each scanline's worth of displayable pixel data. Refer to the NTSC/PAL Filtering Burst Read Length Register (CR75) for an explanation of these burst reads.

CR77 NTSC/PAL Filtering Control Register

read/write at I/O address 3B5h/3D5h with index at address 3B4h/3D4h set to 77h

7	6	5	4	3	2	1	0
Text Mode Line Halving (0)	Reserved (Writable) (000)			Hor. Filter Enable (0)	Ver. Filter Enable (0)	Clk Doubling Enable (0)	Filtering Enable (0)

7 VGA Text Mode Scanline Halving

0: Disables VGA text mode scanline halving.

1: Enables VGA text mode scanline halving, where the setting carried in the Maximum Scanline Register (CR09) and that carried by bits 4-0 of the Text Cursor End Register (CR0B) are halved. This is done to cut the number of scanlines actually sent to the display from VGA standard quantities (such as 400) down to quantities that are more manageable for televisions (such as 200) without actually programming CR09 and bits 4-0 of CR0B with values that are different from VGA standards. This function is meant to be used in conjunction with character fonts that are only half as high as those normally used in VGA text modes.

6-4 Reserved (Writable)

These bits should always be written with the value of 0.

3 Horizontal Flicker Reduction Filtering Enable

Note: Bits 1 and 0 of this register must both be set to 1 in order to enable the flicker reduction filtering hardware, before horizontal flicker reduction filtering can be enabled through this bit.

0: Disables horizontal flicker reduction filtering

1: Enables horizontal flicker reduction filtering where the current pixel is averaged with the pixels immediately to the left and right on the same scanline. This averaging process uses weighted averaging. The current pixel's value is divided by 2, the values of each of the two adjacent pixels is divided by 4, and the resulting three values are added to create the value that is displayed.

2 Vertical Flicker Reduction Filtering Enable

Note: Bits 1 and 0 of this register must both be set to 1 in order to enable the flicker reduction filtering hardware, before vertical flicker reduction filtering can be enabled through this bit.

0: Disables vertical flicker reduction filtering

1: Enables vertical flicker reduction filtering where the pixels of the current scanline are averaged with the pixels of the next scanline as the pixels of the current scanline are being displayed.

1 Internal Clock Doubling Enable

0: One of the internal clocks used by the graphics controller remains at normal clock rates.

1: One of the internal clocks used by the graphics controller is doubled in frequency.

0 Flicker Reduction Filtering Enable

Note: Bit 1 of this register should be set to enable the doubling of an internal clock, before the use of the flicker reduction hardware is enabled by setting this bit to 1.

0: Disables all flicker reduction filter hardware.

1: Enables the use of the flicker reduction filter hardware.

CR78 NTSC/PAL Vertical Reduction Register

read/write at I/O address 3B5h/3D5h with index at address 3B4h/3D4h set to 78h

7	6	5	4	3	2	1	0
Vertical Redux En (0)	Reserved (0)	Reserved (0)	Vertical Reduction Line Dropping Interval (0:0000)				

7 Vertical Reduction Enable

0: Vertical reduction is disabled. This is the default after reset.

1: Vertical reduction is enabled

6-5 Reserved

These bits always return the value of 0 when read.

4-0 Vertical Reduction Line Dropping Interval

When bit 7 of this register is set to 1, these 5 bits specify the number of scanlines remaining (those which will be drawn on the display) between each of the scanlines that are to be dropped (those which will NOT be drawn on the display).

Bit 4 3 2 1 0	Number of Scanlines Remaining Between Dropped Scanlines
0 0 0 0 0	Reserved
0 0 0 0 1	Reserved
0 0 0 1 0 to 1 1 1 1 1	2 to 31

CR79 NTSC/PAL Horizontal Total Fine Adjust Register

read/write at I/O address 3B5h/3D5h with index at address 3B4h/3D4h set to 79h

7	6	5	4	3	2	1	0
Reserved (Writable) (0000:0)					NTSC/PAL Horizontal Total Fine Adjust (000)		

7-3 Reserved

2-0 Horizontal Total Fine Adjust

These 3 bits can be use to specify a number of pixel clocks to be added to the horizontal total specified either by the Horizontal Total Register (CR00) alone in VGA standard modes, or by the Horizontal Total Register (CR00) in conjunction with the Extended Horizontal Total Register (CR38) for extended modes -- both of which specify their respective portions of the horizontal total in units of character clocks. The pixel clock granularity of these 3 bits permit the horizontal total to be specified with greater precision than is possible with character clocks, alone.

Chapter 10

Sequencer Registers

Name	Function	Access (via 3C5)	Index Value In 3C4 (SRX)
SR00	Reset Register	read/write	00
SR01	Clocking Mode Register	read/write	01
SR02	Plane Mask Register	read/write	02
SR03	Character Map Select Register	read/write	03
SR04	Memory Mode Register	read/write	04
SR07	Horizontal Character Counter Reset Register	read/write	07

The sequencer registers are accessed by writing the index of the desired register into the VGA Sequencer Index Register (SRX) at I/O address 3C4, and then accessing the desired register through the data port for the sequencer registers at I/O address 3C5.

SRX Sequencer Index Register

read/write at I/O address 3C4h

This register is cleared to 00h by reset.

7	6	5	4	3	2	1	0
Reserved					Sequencer Register Index		

7-3 Reserved

2-0 Sequencer Register Index

These three bits are used to select any one of the sequencer registers, SR00 through SR07, to be accessed via the data port at I/O location 3C5.

Note: SR02 is referred to in the VGA standard as the Map Mask Register. However, the word "map" is used with multiple meanings in the VGA standard and was therefore deemed too confusing, hence the reason for calling it the Plane Mask Register.

Note: SR07 is a standard VGA register that was not documented by IBM. It is not a CHIPS extension.

SR00 Reset Register

read/write at I/O address 3C5h with index at address 3C4h set to 00h

7	6	5	4	3	2	1	0
Reserved						Sync Reset	Async Reset

7-2 Reserved

1 Synchronous Reset

Setting this bit to 0 commands the sequencer to perform a synchronous clear and then halt. The sequencer should be reset via this bit before changing the Clocking Mode Register (SR01) if the memory contents are to be preserved. However, leaving this bit set to 0 for longer than a few tenths of a microsecond can still cause data loss in the frame buffer. No register settings are changed by performing this type of reset.

0: Forces synchronous reset and halt

1: Permits normal operation

0 Asynchronous Reset

Setting this bit to 0 commands the sequencer to perform a clear and then halt. Resetting the sequencer via this bit can cause data loss in the frame buffer. No register settings are changed by performing this type of reset.

0: Forces asynchronous reset

1: Permits normal operation

SR01 Clocking Mode Register

read/write at I/O address 3C5h with index at address 3C4h set to 01h

7	6	5	4	3	2	1	0
Reserved		Screen Off	Shift 4	Dot Clock Divide	Shift Load	Reserved	8/9 Dot Clocks

7-6 Reserved

5 Screen Off

0: Permits normal operation

1: Disables all graphics output except for video playback windows and turns off the picture-generating logic allowing the full memory bandwidth to be available for both host CPU accesses and accesses by the multimedia engine for video capture and playback functions. Synchronization pulses to the display, however, are maintained. Setting this bit to 1 can be used as a way to more rapidly update the frame buffer.

4 Shift 4

0: Causes the video data shift registers to be loaded every 1 or 2 character clock cycles, depending on bit 2 of this register.

1: Causes the video data shift registers to be loaded every 4 character clock cycles.

3 Dot Clock Divide

Setting this bit to 1 divides the dot clock by two and stretches all timing periods. This bit is used in standard VGA 40-column text modes to stretch timings to create horizontal resolutions of either 320 or 360 pixels as opposed to 640 or 720 pixels, normally used in standard VGA 80-column text modes.

0: Pixel clock is left unaltered.

1: Pixel clock is divided by 2.

2 Shift Load

This bit is ignored if bit 4 of this register is set to 1.

0: Causes the video data shift registers to be loaded on every character clock, if bit 4 of this register is set to 0.

1: Causes the video data shift registers to be loaded every 2 character clocks, provided that bit 4 of this register is set to 0.

1 Reserved

0 8/9 Dot Clocks

0: Selects 9 dot clocks (9 horizontal pixels) per character in text modes with a horizontal resolution of 720 pixels

1: Selects 8 dot clocks (8 horizontal pixels) per character in text modes with a horizontal resolution of 640 pixels

SR02 Plane Mask Register

read/write at I/O address 3C5h with index at address 3C4h set to 02h

7	6	5	4	3	2	1	0
Reserved				Memory Plane 3	Memory Plane 2	Memory Plane 1	Memory Plane 0

Note: This register is referred to in the VGA standard as the Map Mask Register. However, the word “map” is used with multiple meanings in the VGA standard and was, therefore, deemed too confusing, hence the reason for calling it the Plane Mask Register.

7-4 Reserved

3-0 Memory Plane 3 through Memory Plane 0

These four bits of this register control processor write access to the four memory maps:

0: Disables CPU write access to the given memory plane

1: Enables CPU write access to the given memory plane

In both the Odd/Even Mode and the Chain 4 Mode, these bits still control access to the corresponding color plane.

SR03 Character Map Select Register

read/write at I/O address 3C5h with index at address 3C4h set to 03h

7	6	5	4	3	2	1	0
Reserved		Char Map A Select (bit 0)	Char Map B Select (bit 0)	Character Map A Select (bits 2 and 1)		Character Map B Select (bits 2 and 1)	

Note: In text modes, bit 3 of the video data's attribute byte normally controls the foreground intensity. This bit may be redefined to control switching between character sets. This latter function is enabled whenever there is a difference in the values of the Character Font Select A and the Character Font Select B bits. If the two values are the same, the character select function is disabled and attribute bit 3 controls the foreground intensity.

7-6 Reserved

5, 3-2 Character Map Select Bits for Character Map A

These three bits are used to select the character map (character generator tables) to be used as the secondary character set (font). Note that the numbering of the maps is not sequential.

Bit 3 2	Bit 5	Map Number	Table Location
0 0	0	0	1st 8KB of plane 2 at offset 0
0 0	1	4	2nd 8KB of plane 2 at offset 8K
0 1	0	1	3rd 8KB of plane 2 at offset 16K
0 1	1	5	4th 8KB of plane 2 at offset 24K
1 0	0	2	5th 8KB of plane 2 at offset 32K
1 0	1	6	6th 8KB of plane 2 at offset 40K
1 1	0	3	7th 8KB of plane 2 at offset 48K
1 1	1	7	8th 8KB of plane 2 at offset 56K

4, 1-0 Character Map Select Bits for Character Map B

These three bits are used to select the character map (character generator tables) to be used as the primary character set (font). Note that the numbering of the maps is not sequential.

Bit 1 0	Bit 4	Map Number	Table Location
0 0	0	0	1st 8KB of plane 2 at offset 0
0 0	1	4	2nd 8KB of plane 2 at offset 8K
0 1	0	1	3rd 8KB of plane 2 at offset 16K
0 1	1	5	4th 8KB of plane 2 at offset 24K
1 0	0	2	5th 8KB of plane 2 at offset 32K
1 0	1	6	6th 8KB of plane 2 at offset 40K
1 1	0	3	7th 8KB of plane 2 at offset 48K
1 1	1	7	8th 8KB of plane 2 at offset 56K

Note: Bit 1 of the Memory Mode Register (SR04) must be set to 1 for the character font select function of this register to be active. Otherwise, only character maps 0 and 4 are available.

SR04 Memory Mode Register

read/write at I/O address 3C5h with index at address 3C4h set to 04h

7	6	5	4	3	2	1	0
Reserved				Chain 4	Odd/ Even	Extended Memory	Reserved

7-4 Reserved

3 Chain 4 Mode

0: The manner in which the frame buffer memory is mapped is determined by the setting of bit 2 of this register.

1: The frame buffer memory is mapped in such a way that the function of address bits 0 and 1 are altered so that they select planes 0 through 3.

The selections made by this bit affect both CPU read and write accesses to the frame buffer.

2 Odd/Even Mode

0: The frame buffer is mapped so that address bit 0 is used to select between sets of planes such that even addresses select memory planes 0 and 2 and odd addresses select memory planes 1 and 3.

1: Addresses sequentially access data within a bit map, and the choice of which map is accessed is made according to the value of the Plane Mask Register (SR02).

Note: Bit 3 of this register must be set to 0 for this bit to be effective. The selections made by this bit affect only CPU writes to the frame buffer.

Note: This works in a way that is the inverse of (and is normally set to be the opposite of) bit 2 of the Memory Mode Register (SR04).

1 Extended Memory Enable

0: Disable CPU accesses to more than the first 64KB of VGA standard memory.

1: Enable CPU accesses to the rest of the 256KB total VGA memory beyond the first 64KB. This bit must be set to 1 to enable the selection and use of character maps in plane 2 via the Character Map Select Register (SR03).

0 Reserved

SR07 Horizontal Character Counter Reset Register

read/write at I/O address 3C5h with index at address 3C4h set to index 07h

7	6	5	4	3	2	1	0
Horizontal Character Counter Reset							

Writing this register with any data will cause the horizontal character counter to be held in reset (the character counter output will remain 0) until a write occurs to any other sequencer register location with SRX set to an index of 0 through 6.

The vertical line counter is clocked by a signal derived from the horizontal display enable (which does not occur if the horizontal counter is held in reset). Therefore, if a write occurs to this register occurs during the vertical retrace interval, both the horizontal and vertical counters will be set to 0. A write to any other sequencer register location (with SRX set to an index of 0 through 6) may then be used to start both counters with reasonable synchronization to an external event via software control.

This is a standard VGA register which was not documented by IBM.

Chapter 11

Graphics Controller Registers

Name	Function	Access (via 3CF)	Index Value In 3CE (GRX)
GR00	Set/Reset Register	read/write	00h
GR01	Enable Set/Reset Register	read/write	01h
GR02	Color Compare Register	read/write	02h
GR03	Data Rotate Register	read/write	03h
GR04	Read Map Select Register	read/write	04h
GR05	Graphics Mode Register	read/write	05h
GR06	Miscellaneous Register	read/write	06h
GR07	Color Don't Care Register	read/write	07h
GR08	Bit Mask Register	read/write	08h

The graphics controller registers are accessed by writing the index of the desired register into the VGA Graphics Controller Index Register (GRX) at I/O address 3CE, then accessing the desired register through the data port for the graphics controller registers located at I/O address 3CF.

GRX Graphics Controller Index Register

read/write at I/O address 3CEh

This register is cleared to 00h by reset.

7	6	5	4	3	2	1	0
Reserved				Graphics Controller Register Index			

7-4 Reserved

3-0 Graphics Controller Register Index

These four bits are used to select any one of the graphics controller registers, GR00 through GR08, to be accessed via the data port at I/O location 3CF.

GR00 Set/Reset Register

read/write at I/O address 3CFh with index at address 3CEh set to 00h

7	6	5	4	3	2	1	0
Reserved				Set/Reset Plane 3	Set/Reset Plane 2	Set/Reset Plane 1	Set/Reset Plane 0

7-4 Reserved

3-0 Set/Reset Plane 3 through Set/Reset Plane 0

When the Write Mode bits (bits 0 and 1) of the Graphics Mode Register (GR05) are set to select Write Mode 0, all 8 bits of each byte of each memory plane are set to either 1 or 0 as specified in the corresponding bit in this register if the corresponding bit in the Enable Set/Reset Register (GR01) is set to 1.

When the Write Mode bits (bits 0 and 1) of the Graphics Mode Register (GR05) are set to select Write Mode 3, all CPU data written to the frame buffer is rotated, then logically ANDed with the contents of the Bit Mask Register (GR08) and then treated as the addressed data's bit mask, while value of these four bits of this register are treated as the color value.

GR01 Enable Set/Reset Register

read/write at I/O address 3CFh with index at address 3CEh set to 01h

7	6	5	4	3	2	1	0
Reserved				Enbl Set/ Reset Pln 3	Enbl Set/ Reset Pln 2	Enbl Set/ Reset Pln 1	Enbl Set/ Reset Pln 0

7-4 Reserved

3-0 Enable Set/Reset Plane 3 through Enable Set/Reset Plane 0

0: The corresponding memory plane can be read from or written to by the CPU without any special bitwise operations taking place.

1: The corresponding memory plane is set to 0 or 1 as specified in the Set/Reset Register (GR00).

This register works in conjunction with the Set/Reset Register (GR00). The Write Mode bits (bits 0 and 1) must be set for Write Mode 0 for this register to have any effect.

GR02 Color Compare Register

read/write at I/O address 3CFh with index at address 3CEh set to 02h

7	6	5	4	3	2	1	0
Reserved				Color Comp Plane 3	Color Comp Plane 2	Color Comp Plane 1	Color Comp Plane 0

7-4 Reserved

3-0 Color Compare Plane 3 through Color Compare Plane 0

When the Read Mode bit (bit 3) of the Graphics Mode Register (GR05) is set to select Read Mode 1, all 8 bits of each byte of each of the 4 memory planes of the frame buffer corresponding to the address from which a CPU read access is being performed are compared to the corresponding bits in this register (if the corresponding bit in the Color Don't Care Register (GR07) is set to 1). The value that the CPU receives from the read access is an 8-bit value that shows the result of this comparison, wherein a value of 1 in a given bit position indicates that all of the corresponding bits in the bytes across all of the memory planes that were included in the comparison had the same value as their memory plane's respective bits in this register.

GR03 Data Rotate Register

read/write at I/O address 3CFh with index at address 3CEh set to 03h

7	6	5	4	3	2	1	0
Reserved			Function Select		Rotate Count		

7-5 Reserved

4-3 Function Select

These bits specify the logical function (if any) to be performed on data that is meant to be written to the frame buffer (using the contents of the memory read latch) just before it is actually stored in the frame buffer at the intended address location.

Bit 4 5	Result
0 0	Data being written to the frame buffer remains unchanged, and is simply stored in the frame buffer.
0 1	Data being written to the frame buffer is logically ANDed with the data in the memory read latch before it is actually stored in the frame buffer.
1 0	Data being written to the frame buffer is logically ORed with the data in the memory read latch before it is actually stored in the frame buffer.
1 1	Data being written to the frame buffer is logically XORed with the data in the memory read latch before it is actually stored in the frame buffer.

2-0 Rotate Count

These bits specify the number of bits to the right to rotate any data that is meant to be written to the frame buffer just before it is actually stored in the frame buffer at the intended address location.

GR04 Read Plane Select Register

read/write at I/O address 3CFh with index at address 3CEh set to 04h

7	6	5	4	3	2	1	0
Reserved						Read Plane Select	

7-2 Reserved

1-0 Read Plane Select

These two bits select the memory plane from which the CPU reads data in Read Mode 0. In Odd/Even Mode, bit 0 of this register is ignored. In Chain 4 Mode, both bits 1 and 0 of this register are ignored. The four memory planes are selected as follows:

Bits 1 0	Plane Selected
0 0	Plane 0
0 1	Plane 1
1 0	Plane 2
1 1	Plane 3

These two bits also select which of the four memory read latches may be read via the Memory Read Latch Data Register (CR22). The choice of memory read latch corresponds to the choice of plane specified in the table above. The Memory Read Latch Data register and this additional function served by 2 bits are features of the VGA standard that were never documented by IBM.

GR05 Graphics Mode Register

read/write at I/O address 3CFh with index at address 3CEh set to 05h

7	6	5	4	3	2	1	0
Reserved	Shift Register Control		Odd/ Even	Read Mode	Reserved	Write Mode	

7 Reserved

6-5 Shift Register Control

In standard VGA modes, pixel data is transferred from the 4 graphics memory planes to the palette via a set of 4 serial output bits. These 2 bits of this register control the format in which data in the 4 memory planes is serialized for these transfers to the palette.

0, 0: One bit of data at a time from parallel bytes in each of the 4 memory planes is transferred to the palette via the 4 serial output bits, with 1 of each of the serial output bits corresponding to a memory plane. This provides a 4-bit value on each transfer for 1 pixel, making possible a choice of 1 of 16 colors per pixel.

Serial Out	1st Xfer	2nd Xfer	3rd Xfer	4th Xfer	5th Xfer	6th Xfer	7th Xfer	8th Xfer
Bit 3	plane 3 bit 7	plane 3 bit 6	plane 3 bit 5	plane 3 bit 4	plane 3 bit 3	plane 3 bit 2	plane 3 bit 1	plane 3 bit 0
Bit 2	plane 2 bit 7	plane 2 bit 6	plane 2 bit 5	plane 2 bit 4	plane 2 bit 3	plane 2 bit 2	plane 2 bit 1	plane 2 bit 0
Bit 1	plane 1 bit 7	plane 1 bit 6	plane 1 bit 5	plane 1 bit 4	plane 1 bit 3	plane 1 bit 2	plane 1 bit 1	plane 1 bit 0
Bit 0	plane 0 bit 7	plane 0 bit 6	plane 0 bit 5	plane 0 bit 4	plane 0 bit 3	plane 0 bit 2	plane 0 bit 1	plane 0 bit 0

0, 1: Two bits of data at a time from parallel bytes in each of the 4 memory planes are transferred to the palette in a pattern that alternates per byte between memory planes 0 and 2, and memory planes 1 and 3. First the even-numbered and odd-numbered bits of a byte in memory plane 0 are transferred via serial output bits 0 and 1, respectively, while the even-numbered and odd-numbered bits of a byte in memory plane 2 are transferred via serial output bits 2 and 3. Next, the even-numbered and odd-numbered bits of a byte in memory plane 1 are transferred via serial output bits 0 and 1, respectively, while the even-numbered and odd-numbered bits of memory plane 3 are transferred via serial out bits 1 and 3. This provides a pair of 2-bit values (one 2-bit value for each of 2 pixels) on each transfer, making possible a choice of 1 of 4 colors per pixel.

Serial Out	1st Xfer	2nd Xfer	3rd Xfer	4th Xfer	5th Xfer	6th Xfer	7th Xfer	8th Xfer
Bit 3	plane 2 bit 7	plane 2 bit 5	plane 2 bit 3	plane 2 bit 1	plane 3 bit 7	plane 3 bit 5	plane 3 bit 3	plane 3 bit 1
Bit 2	plane 2 bit 6	plane 2 bit 4	plane 2 bit 2	plane 2 bit 0	plane 3 bit 6	plane 3 bit 4	plane 3 bit 2	plane 3 bit 0
Bit 1	plane 0 bit 7	plane 0 bit 5	plane 0 bit 3	plane 0 bit 1	plane 1 bit 7	plane 1 bit 5	plane 1 bit 3	plane 1 bit 1
Bit 0	plane 0 bit 6	plane 0 bit 4	plane 0 bit 2	plane 0 bit 0	plane 1 bit 6	plane 1 bit 4	plane 1 bit 2	plane 1 bit 0

This alternating pattern is meant to accommodate the use of the Odd/Even mode of organizing the 4 memory planes, which is used by standard VGA modes 2h and 3h.

1, x: Four bits of data at a time from parallel bytes in each of the 4 memory planes are transferred to the palette in a pattern that iterates per byte through memory planes 0 through 3. First the 4 most significant bits of a byte in memory plane 0 are transferred via the 4 serial output bits, followed by the 4 least significant bits of the same byte. Next, the same transfers occur from the parallel byte in memory planes 1, 2 and lastly, 3. Each transfer provides either the upper or lower half of an 8 bit value for the color for each pixel, making possible a choice of 1 of 256 colors per pixel.

Serial Out	1st Xfer	2nd Xfer	3rd Xfer	4th Xfer	5th Xfer	6th Xfer	7th Xfer	8th Xfer
Bit 3	plane 0 bit 7	plane 0 bit 3	plane 1 bit 7	plane 1 bit 3	plane 2 bit 7	plane 2 bit 3	plane 3 bit 7	plane 3 bit 3
Bit 2	plane 0 bit 6	plane 0 bit 2	plane 1 bit 6	plane 1 bit 2	plane 2 bit 6	plane 2 bit 2	plane 3 bit 6	plane 3 bit 2
Bit 1	plane 0 bit 5	plane 0 bit 1	plane 1 bit 5	plane 1 bit 1	plane 2 bit 5	plane 2 bit 1	plane 3 bit 5	plane 3 bit 1
Bit 0	plane 0 bit 4	plane 0 bit 0	plane 1 bit 4	plane 1 bit 0	plane 2 bit 4	plane 2 bit 0	plane 3 bit 4	plane 3 bit 0

This pattern is meant to accommodate mode 13h, a standard VGA 256-color graphics mode.

4 Odd/Even Mode

0: Addresses sequentially access data within a bit map. The choice of which map is accessed is made according to the value of the Plane Mask Register (SR02).

1: The frame buffer is mapped so that address bit 0 is used to select between sets of planes such that even addresses select memory planes 0 and 2 and odd addresses select memory planes 1 and 3.

Note: This works in a way that is the inverse of (and is normally set to be the opposite of) bit 2 of the Memory Mode Register (SR04).

3 Read Mode

0: During a CPU read from the frame buffer, the value returned to the CPU is data from the memory plane selected by bits 1 and 0 of the Read Plane Select Register (GR04).

1: During a CPU read from the frame buffer, all 8 bits of the byte in each of the 4 memory planes corresponding to the address from which a CPU read access is being performed are compared to the corresponding bits in this register (if the corresponding bit in the Color Don't Care Register (GR07) is set to 1). The value that the CPU receives from the read access is an 8-bit value that shows the result of this comparison, wherein value of 1 in a given bit position indicates that all of the corresponding bits in the bytes across all 4 of the memory planes that were included in the comparison had the same value as their memory plane's respective bits in this register.

2 Reserved**1-0 Write Mode**

0, 0: Write Mode 0 -- During a CPU write to the frame buffer, the addressed byte in each of the 4 memory planes is written with the CPU write data after it has been rotated by the number of counts specified in the Data Rotate Register (GR03). If, however, the bit(s) in the Enable Set/Reset Register (GR01) corresponding to one or more of the memory planes is set to 1, then those memory planes will be written to with the data stored in the corresponding bits in the Set/Reset Register (GR00).

0, 1: Write Mode 1 -- During a CPU write to the frame buffer, the addressed byte in each of the 4 memory planes is written to with the data stored in the memory read latches (the memory read latches stores an unaltered copy of the data last read from any location in the frame buffer).

1, 0: Write Mode 2 -- During a CPU write to the frame buffer, the least significant 4 data bits of the CPU write data are treated as the color value for the pixels in the addressed byte in all 4 memory planes. The 8 bits of the Bit Mask Register (GR08) are used to selectively enable or disable the ability to write to the corresponding bit in each of the 4 memory planes that correspond to a given pixel. A setting of 0 in a bit in the Bit Mask Register at a given bit position causes the bits in the corresponding bit positions in the addressed byte in all 4 memory planes to be written with value of their counterparts in the memory read latches. A setting of 1 in a Bit Mask Register at a given bit position causes the bits in the corresponding bit positions in the addressed byte in all 4 memory planes to be written with the 4 bits taken from the CPU write data to thereby cause the pixel corresponding to these bits to be set to the color value.

1, 1: Write Mode 3 -- During a CPU write to the frame buffer, the CPU write data is logically ANDed with the contents of the Bit Mask Register (GR08). The result of this ANDing is treated as the bit mask used in writing the contents of the Set/Reset Register (GR00) are written to addressed byte in all 4 memory planes.

GR06 Miscellaneous Register

read/write at I/O address 3CFh with index at address 3CEh set to 06h

7	6	5	4	3	2	1	0
Reserved				Memory Map Mode		Chain Odd/ Even	Graphics / Text Mode

7-4 Reserved

3-2 Memory Map Mode

These 2 bits control the mapping of the frame buffer into the CPU address space as follows:

Bits 3 2	Frame Buffer Address Range
0 0	A0000h - BFFFFh
0 1	A0000h - AFFFFh
1 0	B0000h - B7FFFh
1 1	B8000h - BFFFFh

Note: This function is both in standard VGA modes and in extended modes that do not provide linear frame buffer access.

1 Chain Odd/Even

This bit provides the ability to alter the interpretation of address bit A0, so that it may be used in selecting between the odd-numbered memory planes (planes 1 and 3) and the even-numbered memory planes (planes 0 and 2).

0: A0 functions normally.

1: A0 is switched with a high order address bit, in terms of how it is used in address decoding. The result is that A0 is used to determine which memory plane is being accessed:

A0 = 0: planes 0 and 2

A0 = 1: planes 1 and 3

0 Graphics/Text Mode

0: Selects text mode.

1: Selects graphics mode.

GR07 Color Don't Care Register

read/write at I/O address 3CFh with index at address 3CEh set to 07h

7	6	5	4	3	2	1	0
Reserved				Ignore Color Plane 3	Ignore Color Plane 2	Ignore Color Plane 1	Ignore Color Plane 0

7-4 Reserved

3-0 Ignore Color Plane 3 through Ignore Color Plane 0

0: The corresponding bit in the Color Compare Register (GR02) will not be included in color comparisons.

1: The corresponding bit in the Color Compare Register (GR02) is used in color comparisons.

Note: These bits have effect only when bit 3 of the Graphics Mode Register (GR05) is set to 1 to select read mode 1.

GR08 Bit Mask Register

read/write at I/O address 3CFh with index at address 3CEh set to 08h

7	6	5	4	3	2	1	0
Bit Mask							

7-0 Bit Mask

0: The corresponding bit in each of the 4 memory planes is written to with the corresponding bit in the memory read latches.

1: Manipulation of the corresponding bit in each of the 4 memory planes via other mechanisms is enabled.

Note: This bit mask applies to any writes to the addressed byte of any or all of the 4 memory planes simultaneously.

Note: This bit mask is applicable to any data written into the frame buffer by the CPU, including data that is also subject to rotation, logical functions (AND, OR, XOR), and Set/Reset. To perform a proper read-modify-write cycle into the frame buffer, each byte must first be read from the frame buffer by the CPU (and this will cause it to be stored in the memory read latches), this Bit Mask Register must be set and the new data then written into the frame buffer by the CPU.

Chapter 12

Attribute Controller Registers

Name	Function	Access	Index
AR00-AR0F	Color Data Registers	read/write	00-0F
AR10	Mode Control Register	read/write	10
AR11	Overscan Color Register	read/write	11
AR12	Memory Plane Enable Register	read/write	12
AR13	Horizontal Pixel Panning Register	read/write	13
AR14	Color Select Register	read/write	14

Unlike the other sets of indexed registers, the attribute controller registers are not accessed through a scheme employing entirely separate index and data ports. I/O address 3C0h is used both as the read and write for the index register, and as the write address for the data port. I/O address 3C1h is the read address for the data port.

To write to one of the attribute controller registers, the index of the desired register must be written to I/O address 3C0h and then the data is written to the very same I/O address. A flip-flop alternates with each write to I/O address 3C0h to change its function from writing the index to writing the actual data and back again. This flip-flop may be deliberately set so that I/O address 3C0h is set to write to the index (which provides a way to set it to a known state) by performing a read operation from Input Status Register 1 (ST01) at I/O address 3BAh or 3DAh (depending on whether the graphics system has been set to emulate an MDA or a CGA).

To read from one of the attribute controller registers, the index of the desired register must be written to I/O address 3C0h and then the data is read from I/O address 3C1h. A read operation from I/O address 3C1h does not reset the flip-flop to writing to the index. Only a write to 3C0h or a read from 3BAh or 3DAh, as described above, will toggle the flip-flop back to writing to the index.

ARX Attribute Controller Index Register

read/write at I/O address 3C0h

7	6	5	4	3	2	1	0
Reserved		Video Enable	Attribute Controller Register Index				

Note: AR12 is referred to in the VGA standard as the Color Plane Enable Register. The words “plane,” “color plane,” “display memory plane,” and “memory map” have been all been used in IBM® literature on the VGA standard to describe the four separate regions in the frame buffer where the pixel color or attribute information is split up and stored in standard VGA planar modes. This use of multiple terms for the same subject was deemed to be confusing, therefore AR12 is called the Memory Plane Enable Register.

7-6 Reserved

5 Video Enable

0: Disables video, allowing the attribute controller color registers (AR00-AR0F) to be accessed by the CPU.

1: Enables video, causing the attribute controller color registers (AR00-AR0F) to be rendered inaccessible by the CPU.

Note: In the VGA standard, this is called the “Palette Address Source” bit.

4-0 Attribute Controller Register Index

These five bits are used to select any one of the attribute controller registers, AR00 through AR14, to be accessed.

AR00-AR0F Palette Registers 0-F

read at I/O address 3C1h, write at I/O address 3C0h with index at address 3C0h set to 00h to 0Fh

7	6	5	4	3	2	1	0
Reserved		Palette Bits P5-P0					

Note: Bits 3 and 2 of the Color Select Register (AR14) supply bits P7 and P6 for the values contained in all 16 of these registers. Bits 1 and 0 of the Color Select Register (AR14) can also replace bits P5 and P4 for the values contained in all 16 of these registers if bit 7 of the Mode Control Register (AR10) is set to 1.

7-6 Reserved

5-0 Palette Bits P5-P0

In each of these 16 registers, these are the lower 6 of 8 bits that are used to map either text attributes or pixel color input values (for modes that use 16 colors) to the 256 possible colors available to be selected in the palette.

AR10 Mode Control Register

read at I/O address 3C1h, write at I/O address 3C0h with index at address 3C0h set to 10h

7	6	5	4	3	2	1	0
Palette Bits P5, P4 Select	Pixel Width/ Clk Select	Pixel Panning Compat	Reserved	En Blink/ SelectBkgnd Int	En Line Gr Char Code	Select Display Type	Graphics/ Alpha Mode

7 Palette Bits P5, P4 Select

- 0: P5 and P4 for each of the 16 selected colors (for modes that use 16 colors) are individually provided by bits 5 and 4 of their corresponding Palette Registers (AR00-0F).
- 1: P5 and P4 for all 16 of the selected colors (for modes that use 16 colors) are provided by bits 1 and 0 of Color Select Register (AR14).

6 Pixel Width/Clock Select

- 0: Six bits of video data (translated from 4 bits via the palette) are output every dot clock.
 - 1: Two sets of 4 bits of data are assembled to generate 8 bits of video data which is output every other dot clock, and the Palette Registers (AR00-0F) are bypassed.
- Note: This bit is set to 0 for all of the standard VGA modes, except mode 13h.

5 Pixel Panning Compatibility

- 0: Scroll both the upper and lower screen regions horizontally as specified in the Horizontal Pixel Panning Register (AR13).
- 1: Scroll only the upper screen region horizontally as specified in the Horizontal Pixel Panning Register (AR13).

Note: This bit has application only when split-screen mode is being used, where the display area is divided into distinct upper and lower regions which function somewhat like separate displays.

4 Reserved

3 Enable Blinking/Select Background Intensity

- 0: Disables blinking in graphics modes and, in text modes, sets bit 7 of the character attribute bytes to control background intensity, instead of blinking.
- 1: Enables blinking in graphics modes and, in text modes, sets bit 7 of the character attribute bytes to control blinking, instead of background intensity.

Note: The blinking rate is derived by dividing the VSYNC signal. The Blink Rate Control Register (FR19) defines the blinking rate.

2 Enable Line Graphics Character Code

0: Every 9th pixel of a horizontal line (i.e., the last pixel of each horizontal line of each 9-pixel wide character box) is assigned the same attributes as the background of the character of which the given pixel is a part.

1: Every 9th pixel of a horizontal line (i.e., the last pixel of each horizontal line of each 9-pixel wide character box) is assigned the same attributes as the 8th pixel of the character of which the given pixel is a part. This setting is intended to accommodate the line-drawing characters of the PC's extended ASCII character set -- characters with an extended ASCII code in the range of B0h to DFh.

Note: In IBM® literature describing the VGA standard, the range of extended ASCII codes that are said to include the line-drawing characters is mistakenly specified as C0h to DFh, rather than the correct range of B0h to DFh.

1 Select Display Type

0: Attribute bytes in text modes are interpreted as they would be for a color display.

1: Attribute bytes in text modes are interpreted as they would be for a monochrome display.

0 Graphics/Alphanumeric Mode

0: Selects alphanumeric (text) mode.

1: Selects graphics mode.

AR11 Overscan Color Register

read at I/O address 3C1h, write at I/O address 3C0h with index at address 3C0h set to 11h

7	6	5	4	3	2	1	0
Overscan Color							

7-0 Overscan

These 8 bits select the overscan (border) color. The border color is displayed during the blanking intervals. For monochrome displays, this value should be set to 00h.

AR12 Memory Plane Enable Register

read at I/O address 3C1h, write at I/O address 3C0h with index at address 3C0h set to 12h

7	6	5	4	3	2	1	0
Reserved		Video Status Mux		Enable Plane 3	Enable Plane 2	Enable Plane 1	Enable Plane 0

Note: AR12 is referred to in the VGA standard as the Color Plane Enable Register. The words “plane,” “color plane,” “display memory plane,” and “memory map” have been all been used in IBM® literature on the VGA standard to describe the 4 separate regions in the frame buffer that are amongst which pixel color or attributes information is split up and stored in standard VGA planar modes. This use of multiple terms for the same subject was deemed to be confusing, therefore AR12 is called the Memory Plane Enable Register.

7-6 Reserved

5-4 Video Status Mux

These 2 bits are used to select 2 of the 8 possible palette bits (P7-P0) to be made available to be read via bits 5 and 4 of the Input Status Register 1 (ST01). The table below shows the possible choices.

AR12 Bit 5 4	ST01 Bit 5 4
0 0	P2 P0
0 1	P5 P4
1 0	P3 P1
1 1	P7 P6

Note: These bits are largely unused by current software. They are provided for EGA compatibility.

3-0 Enable Plane 3-0

These 4 bits individually enable the use of each of the 4 memory planes in providing 1 of the 4 bits used in video output to select 1 of 16 possible colors from the palette to be displayed.

- 0: Disables the use of the corresponding memory plane in video output to select colors, forcing the bit that the corresponding memory plane would have provided to a value of 0.
- 1: Enables the use of the corresponding memory plane in video output to select colors.

AR13 Horizontal Pixel Panning Register

read at I/O address 3C1h, write at I/O address 3C0h with index at address 3C0h set to 13h

7	6	5	4	3	2	1	0
Reserved				Horizontal Pixel Shift			

7-4 Reserved

3-0 Horizontal Pixel Shift

Bits 3-0 of this register hold a 4-bit value that selects number of pixels by which the image is shifted horizontally to the left. This function is available in both text and graphics modes. In text modes with a 9-pixel wide character box, the image can be shifted up to 8 pixels to the left. In text modes with an 8-pixel wide character box, and in graphics modes other than those with 256 colors, the image can be shifted up to 7 pixels to the left.

In standard VGA mode 13h (where bit 6 of the Mode Control Register, AR10, is set to 1 to support 256 colors), bit 0 of this register must remain set to 0, and the image may be shifted up to only 3 pixels to the left. In this mode, the number of pixels by which the image is shifted can be further controlled using bits 6 and 5 of the Preset Row Scan Register (CR08).

Number of Pixels Shifted			
Value in Bits 3-0	9 Pixel Text	8-Pixel Text & Graphics	256-Color Graphics
0h	1	0	0
1h	2	1	Undefined
2h	3	2	1
3h	4	3	Undefined
4h	5	4	2
5h	6	5	Undefined
6h	7	6	3
7h	8	7	Undefined
8h	0	Undefined	Undefined

AR14 Color Select Register

read at I/O address 3C1h, write at I/O address 3C0h with index at address 3C0h set to 14h

7	6	5	4	3	2	1	0
Reserved				P7	P6	Alt P5	Alt P4

7-4 Reserved

3-2 Palette Bits P7 and P6

These are the 2 upper-most of the 8 bits that are used to map either text attributes or pixel color input values (for modes that use 16 colors) to the 256 possible colors contained in the palette. These 2 bits are common to all 16 sets of bits P5 through P0 that are individually supplied by Palette Registers 0-F (AR00-AR0F).

1-0 Alternate Palette Bits P5 and P4

These 2 bits can be used as an alternate version of palette bits P5 and P4. Unlike the P5 and P4 bits that are individually supplied by Palette Registers 0-F (AR00-AR0F), these 2 alternate palette bits are common to all 16 of Palette Registers. Bit 7 of the Mode Control Register (AR10) is used to select between the use of either the P5 and P4 bits that are individually supplied by the 16 Palette Registers or these 2 alternate palette bits.

Chapter 13

Palette Registers

Name	Function	Access	I/O Address
PALMASK	Palette Data Mask Register	read/write	3C6h
PALSTATE	Palette State Register	read-only	3C7h
PALRX	Palette Read Index Register	write-only	3C7h
PALWX	Palette Write Index Register	read/write	3C8h
PALDATA	Palette Data Register	read/write	3C9h

History

The original VGA graphics system and earlier compatible ones had a distinct IC called either the RAMDAC or the palette DAC. The RAMDAC was made up of two main components: a 256x24bit color lookup table (CLUT) or palette in which a selection of 256 colors may be stored and a set of three digital-to-analog converters (DACs), one each for the red, green and blue components used to produce a color on a CRT display. Despite the integration of both the palette and the triplet of DACs into larger ICs in many present day graphics systems, the terms RAMDAC and palette DAC remain in common use.

However, this integration of both the palette and DACs into the graphics controller makes the use of such terms as RAMDAC and palette DAC erroneous, especially in the case of this graphics controller. This graphics controller has two outputs: the DACs which are normally used to drive a CRT display, and a flat-panel interface that is normally used to drive LCD or other types of flat panel displays. Either one or both of these outputs may be used at any given time and the pixel data sent to one or both of these outputs may or may not be routed through the palette. In short, the palette and DACs of this graphics controller can be used entirely independently of each other and for this reason, these registers have been renamed in a manner more in keeping with their actual purpose (e.g., the original VGA standard name of 'DACSTATE' has been replaced with 'PALSTATE').

Color Depths and the Palette

Whether or not the palette is used depends entirely on the color depth to which the graphics system has been set via bits 3-0 of XR81.

The palette is NOT used for modes with color depths greater than 8 bits per pixel. The data stored in the frame buffer is the actual color data, not an index. The appropriate bits describing the intensities of the red, green and blue components are retrieved from the frame buffer and routed to whichever output is being used. The palette is entirely bypassed, and so these are referred to as direct-color modes.

The palette is used for modes with color depths of 8 bits per pixel or less. The color data stored in the frame buffer and received by the palette is actually an index that selects a location within the palette in which the components of a color is specified. The 3-bytes of the selected color are sent from the palette to whichever output (CRT or flat panel or both) is being used. Due to this use of an index into a palette, these modes are referred to as indexed modes.

The use of indexed modes allows the main display image to take up less space in the frame buffer and allows the actual displayed colors to be specified independently. The latter feature has been known to be used in such applications as video games.

Accessing Color Data Locations Within the Palette

A complex sub-indexing scheme using separate read and write access indices and a data port is used to access both the standard and alternate palette locations within the palette where color data is stored. The Palette Read Index Register is used to select the palette location to be read from via the Palette Data Register, while the Palette Write Index Register is used to select the palette location to be written to. This arrangement allows the same data port to be used for reading from and writing to two different palette locations.

To read a palette location, the index of the desired palette location must first be written to the Palette Read Index Register. Then all three bytes of data in that palette location may be read, one at a time, via the Palette Data Register. The first byte read from the Palette Data Register retrieves the 8-bit value specifying the intensity of the red color component while the second and third byte reads are for the green and blue color components, respectively. After completing the third read operation, the Palette Read Index Register is automatically incremented so that the data of the next palette location becomes accessible for being read. This allows the contents of all 256 palette locations to be read by specifying only the index of the 0th location in the Palette Read Index Register, and then simply performing 768 successive reads from the Palette Data Register.

Writing palette locations entails a very similar procedure. The index of the desired palette location must first be written to the Palette Write Index Register. Then all three bytes of data to specify a given color may be written, one at a time, to the selected palette location via the Palette Data Register. The first byte written to the Palette Data Register specifies the intensity of the red color component, while the second and third byte writes are for the green and blue color components, respectively. One important detail is that all three of these bytes must be written before the hardware will actually update these three values in the selected palette location. When all three bytes have been written, the Palette Write Index Register is automatically incremented so that the next palette location becomes accessible for being written. This allows the contents of all 256 palette locations to be written by specifying only the index of the 0th palette location in the Palette Write Index Register, and then simply performing 768 successive writes to the Palette Data Register.

In addition to the standard set of 256 palette locations, there is also an alternate set of 8 palette locations used to specify the colors used to draw cursors 1 and 2, and these are also accessed using the very same sub-indexing scheme. Bit 0 of the Pixel Pipeline Configuration 0 Register (XR80) determines whether the standard 256 palette locations or the alternate 8 palette locations are to be accessed.

PALMASK Palette Data Mask Register

read/write at I/O address 3C6h

7	6	5	4	3	2	1	0
Pixel Data Mask							

7-0 Pixel Data Mask

In indexed-color mode, the 8 bits of this register are logically ANDed with the 8 bits of pixel data received from the frame buffer for each pixel. The result of this ANDing process becomes the actual index used to select locations within the palette. This has the effect of limiting the choice of palette locations that may be specified by the incoming 8-bit data.

In direct-color mode, the palette is not used, and the data in this register is entirely ignored.

PALSTATE Palette State Register

read-only at I/O address 3C7h

7	6	5	4	3	2	1	0
Reserved						DAC State	

7-2 Reserved

1-0 Palette State

These 2 bits indicate which of the palette two index registers was most recently written to.

Bit 1 0	Palette Index Register Last Written To
0 0	Palette Write Index Register (PALWX) at I/O address 3C8h
0 1	reserved
1 0	reserved
1 1	Palette Read Index Register (PALRX) at I/O address 3C7h

PALRX Palette Read Index Register

write-only at I/O address 3C7h

7	6	5	4	3	2	1	0
Palette Read Index							

7-0 Palette Read Index

This 8-bit value is an index that selects 1 of the 256 standard locations within the palette (or 1 of 8 alternate locations specifically for hardware cursor and popup colors, depending on the setting of bit 0 of XR80) to be read from via the Palette Data Register (PALDATA).

The index value held in this register is automatically incremented when all three bytes of the color data position selected by the current index have been read.

PALWX Palette Write Index Register

read/write at I/O address 3C8

7	6	5	4	3	2	1	0
Palette Write Index							

7-0 Palette Write Index

This 8-bit value is an index that selects 1 of the 256 standard locations within the palette (or 1 of 8 alternate locations specifically for hardware cursor and popup colors, depending on the setting of bit 0 of XR80) to be written to via the Palette Data Register (PALDATA).

The index value held in this register is automatically incremented when all three bytes of the color data position selected by the current index have been written.

PALDATA Palette Data Register

read/write at I/O address 3C9h

7	6	5	4	3	2	1	0
Palette Data							

7-0 Palette Data Register

This byte-wide data port provides read or write access to the three bytes of data carried by palette location selected using the Palette Read Index Register (PALRX) or the Palette Write Index Register (PALWX).

The three bytes in each palette location are written to or read from by making three successive read or write operations. The first byte read or written always specifies the intensity of the red component of the color specified in the selected palette location. The second byte is always for the green component and the third byte is always for the blue component.

When writing data to a palette location, all three bytes must be written before the hardware will actually update the three bytes in that palette location.

When reading or writing to a palette location, it is important to ensure that neither the Palette Read Index Register (PALRX) or the Palette Write Index Register (PALWX) are written to before all three bytes are read or written. The logic that automatically cycles through providing access to the bytes for the red, green and blue color components is reset to start again with the red component after writing to either PALRX or PALWX.

Chapter 14

Extension Registers

Name	Register Function	Access Via Port 3D7	Index Value Port 3D6 (XR _X)
XR00	Vendor ID Low Register	read-only	00h
XR01	Vendor ID High Register	read-only	01h
XR02	Device ID Low Register	read-only	02h
XR03	Device ID High Register	read-only	03h
XR04	Revision ID Register	read-only	04h
XR05	Linear Base Address Low Register	read-only	05h
XR06	Linear Base Address High Register	read-only	06h
XR08	Host Bus Configuration Register	read-only	08h
XR09	I/O Control Register	read/write	09h
XR0A	Frame Buffer Mapping Register	read/write	0Ah
XR0B	PCI Burst Write Support Register	read/write	0Bh
XR0E	Frame Buffer Page Select Register	read/write	0Eh
XR20	BitBLT Configuration Register	read/write	20h
XR40	Memory Access Control Register	read/write	40h
XR41-XR4F	Memory Configuration Registers	read/write	41h-4Fh
XR60	Video Pin Control Register	read/write	60h
XR61	DPMS Sync Control Register	read/write	61h
XR62	GPIO Pin Control Register	read/write	62h
XR63	GPIO Pin Data Register	read/write	63h
XR67	Pin Tri-State Control Register	read/write	67h
XR70	Configuration Pins 0 Register	read-only	70h
XR71	Configuration Pins 1 Register	read-only	71h
XR80	Pixel Pipeline Configuration 0 Register	read/write	80h
XR81	Pixel Pipeline Configuration 1 Register	read/write	81h
XR82	Pixel Pipeline Configuration 2 Register	read/write	82h

Name	Register Function	Access Via Port 3D7	Index Value Port 3D6 (XRX)
XRA0	Cursor 1 Control Register	read/write	A0h
XRA1	Cursor 1 Vertical Extension Register	read/write	A1h
XRA2	Cursor 1 Base Address Low Register	read/write	A2h
XRA3	Cursor 1 Base Address High Register	read/write	A3h
XRA4	Cursor 1 X-Position Low Register	read/write	A4h
XRA5	Cursor 1 X-Position High Register	read/write	A5h
XRA6	Cursor 1 Y-Position Low Register	read/write	A6h
XRA7	Cursor 1 Y-Position High Register	read/write	A7h
XRA8	Cursor 2 Control Register	read/write	A8h
XRA9	Cursor 2 Vertical Extension Register	read/write	A9h
XRAA	Cursor 2 Base Address Low Register	read/write	AAh
XRAB	Cursor 2 Base Address High Register	read/write	ABh
XRAC	Cursor 2 X-Position Low Register	read/write	ACh
XRAD	Cursor 2 X-Position High Register	read/write	ADh
XRAE	Cursor 2 Y-Position Low Register	read/write	A Eh
XRAF	Cursor 2 Y-Position High Register	read/write	AFh
XRC0	Dot Clock 0 VCO M-Divisor Low Register	read/write	C0h
XRC1	Dot Clock 0 VCO N-Divisor Low Register	read/write	C1h
XRC3	Dot Clock 0 Divisor Select Register	read/write	C3h
XRC4	Dot Clock 1 VCO M-Divisor Low Register	read/write	C4h
XRC5	Dot Clock 1 VCO N-Divisor Low Register	read/write	C5h
XRC7	Dot Clock 1 Divisor Select Register	read/write	C7h
XRC8	Dot Clock 2 VCO M-Divisor Low Register	read/write	C8h
XRC9	Dot Clock 2 VCO N-Divisor Low Register	read/write	C9h
XRCB	Dot Clock 2 Divisor Select Register	read/write	CBh
XRCC	Memory Clock VCO M-Divisor Register	read/write	CCh
XRCD	Memory Clock VCO N-Divisor Register	read/write	CDh
XRCE	Memory Clock VCO Divisor Select Register	read/write	CEh
XRCF	Clock Configuration Register	read/write	CFh
XRD0	Powerdown Control Register	read/write	D0h
XRD1	Power Conservation Control Register	read/write	D1h
XRD2	2KHz Down Counter Register	read-only	D2h
XRE0-XREB	Software Flag Registers 0 to B	read/write	E0h-EBh
XRF8-XRFC	Test Registers	read/write	F8h-FCh

XRX Extension Register Index Register

read/write at I/O address 3D6h

This register is cleared to 00h by reset.

7	6	5	4	3	2	1	0
Extension Register Index (0000:0000)							

7-0 Extension Register Index

These 8 bits are used to select any one of the extension registers to be accessed via the data port at I/O location 3D7h.

XR00 Vendor ID Low Register

read-only at I/O address 3D7h with index at I/O address 3D6h set to 00h

7	6	5	4	3	2	1	0
Vendor ID Bits 7-0 (2Ch)							

7-0 Vendor ID Bits 7-0

These 8 bits always carry the value 2Ch. This is the lower byte of CHIPS' vendor ID for PCI devices. Both bytes of this ID are also readable from the Vendor ID register at offset 00h in the PCI configuration space.

XR01 Vendor ID High Register

read-only at I/O address 3D7h with index at I/O address 3D6h set to 01h

7	6	5	4	3	2	1	0
Vendor ID Bits 15-8 (10h)							

7-0 Vendor ID Bits 15-8

These 8 bits always carry the value 10h. This is the upper byte of CHIPS' vendor ID for PCI devices. Both bytes of this ID are also readable from the Vendor ID register at offset 00h in the PCI configuration space.

XR02 Device ID Low Register

read-only at I/O address 3D7h with index at I/O address 3D6h set to 02h

7	6	5	4	3	2	1	0
Device ID Bits 7-0 (C0h)							

7-0 Device ID Bits 7-0

These bits always carry the value C0h. This is the lower byte of the 69000's device ID as a PCI device. Both bytes of this ID are also readable from the Device ID register at offset 02h in the PCI configuration space

XR03 Device ID High Register

read-only at I/O address 3D7h with index at I/O address 3D6h set to 03h

7	6	5	4	3	2	1	0
Device ID High (00h)							

7-0 Device ID High

These bits always carry the value 00h. This is the upper byte of the 69000's device ID as PCI device. Both bytes of this ID are also readable from the Device ID register at offset 02h in the PCI configuration space

XR04 Revision ID Register

read-only at I/O address 3D7h with index at I/O address 3D6h set to 04h

7	6	5	4	3	2	1	0
Chip Manufacturing Code (xxxx)				Chip Revision Code (xxxx)			

Note: This register is identical to the Revision register (REV) at offset 08h in the PCI configuration space.

Note: The default value of this register is 62h.

7-4 Chip Manufacturing Code

These four bits carry the fabrication code.

3-0 Chip Revision Code

These four bits carry the revision code. Revision codes start at 0 and are incremented for each new silicon revision.

XR05 Linear Base Address Low Register

read-only at I/O address 3D7h with index at I/O address 3D6h set to 05h

7	6	5	4	3	2	1	0
Mem Space Base Bit 23 (0)	Reserved (000:0000)						

7 Memory Space Base Address Bit 23

This bit is provided only for backward compatibility only. It is a hold-over from earlier CHIPS graphics controllers.

The graphics controller requires a 16MB memory space on the host bus through which the linear frame buffer and memory-mapped registers are accessed. This 16MB memory space always begins on a 16MB address boundary, so bit 23 of the linear base address of this 16MB memory space always has the value of 0. Therefore this bit always returns the value of 0 when read. This base address is set through the MBASE register at offset 10h in the PCI configuration space.

6-0 Reserved

These bits always return the value of 0 when read.

XR06 Linear Base Address High Register

read-only at I/O address 3D7h with index at I/O address 3D6h set to 06h

7	6	5	4	3	2	1	0
Memory Space Base Address Bits 31-24 (xxxx:xxxx)							

7-0 Memory Space Base Address Bits 31-24

The graphics controller requires a 16MB memory space on the host bus through which the linear frame buffer and memory-mapped registers are accessed. These 8 bits provide read-only access to bits 31-24, the 8 most significant bits of the linear base address at which the 16MB memory space begins. This base address is set through the MBASE register at offset 10h in the PCI configuration space.

XR08 Host Bus Configuration Register

read-only at I/O address 3D7h with index at I/O address 3D6h set to 08h

7	6	5	4	3	2	1	0
Reserved (0000:00)						PCI VGA Addr Dec (x)	Reserved (0)

7-2 Reserved

These bits always return the value of 0 when read.

1 PCI VGA Address Decode Enable

This bit reflects the state of memory interface address pin CFG1 during reset.

0: Indicates that VGA I/O Address decoding is disabled on the PCI Bus, so access to the registers via I/O read and write operations is disabled.

1: Indicates that VGA I/O Address decoding is enabled on the PCI Bus, so access to the registers via I/O read and write operations is enabled.

Note: The reset state of this pin is also readable via bit 1 of the Configuration Pins 0 Register (XR70).

0 Reserved

This bit always returns the value of 0 when read.

XR09 I/O Control Register

read/write at I/O address 3D7h with index at I/O address 3D6h set to 09h

7	6	5	4	3	2	1	0
Reserved (0000:00)						Attr Ctrl Ext Enable (0)	CRT Ctrl Ext Enable (0)

7-2 Reserved

These bits always return the value of 0 when read.

1 Attribute Controller Extensions Enable

0: Allow the sub-addressing scheme used to access the attribute controller registers to remain unchanged from the VGA standard. This is the default after reset.

1: Alter attribute controller sub-addressing scheme used to access the attribute controller registers so that I/O Address 3C0h is used solely as the index register and I/O Address 3C1h is used as the data port for both read and write operations.

0 CRT Controller Extensions Enable

0: Use only the CRT controller registers defined in the VGA standard to extend the number of bits used to specify the timing, resolution and addressing parameters to beyond eight bits. This is the default after reset.

1: Use only the additional CHIPS CRT controller registers to extend the number of bits used to specify the timing, resolution and addressing parameters to beyond eight bits.

XR0A Frame Buffer Mapping Register

read/write at I/O address 3D7h with index at I/O address 3D6h set to 0Ah

7	6	5	4	3	2	1	0
Reserved (00)		Endian Byte Swapping Control (00)		Reserved (0)	Planar to Non X-late (0)	Linear Mapping (0)	Paged Mapping (0)

7-6 Reserved

These bits always return the value of 0 when read.

5-4 Endian Byte Swapping Control

These 2 bits enable and select the type of byte-swapping performed on all word and doubleword data written to and read from the graphics controller by the CPU as follows:

Bits 5 4	Type of Endian Byte Swapping
0 0	No byte swapping. This is the default after reset.
0 1	Performs byte swapping wherein byte 0 is swapped with byte 1 and byte 2 is swapped with byte 3.
1 0	Performs byte swapping wherein byte 0 is swapped with byte 3 and byte 1 is swapped with byte 2.
1 1	Reserved

3 Reserved

This bit always returns the value of 0 when read.

2 Planar to Non-Planar Address Translation Enable

This bit provides a single-bit switch that can be used to alter the manner in which the frame buffer memory appears from the perspective of the host bus to be organized so that it looks as though the bits for each pixel are organized sequentially rather than in planes, even though it may well still be organized in planes. This is done through a hardware-based address translation scheme. The result is intended to be very similar to setting the frame buffer memory to chain-4 mode using the graphics controller registers.

This switch is meant to be turned on occasionally as a convenience to programmers when the graphics controller is being used in standard VGA modes, in order to allow a given drawing operation or frame buffer save or restore operation to be carried out more easily. Altering this bit has no effect on the settings in the graphics controller registers (the GRxx series registers) that are normally used to specify the way in which the frame buffer memory is organized. It is recommended, however, that bits 3 and 2 of the Miscellaneous Register (GR06) be set so that the frame buffer memory is accessible using the A0000-AFFFF memory space during the time that this feature is used.

- 0: Disables address translation in support of packed mode. This is the default after reset.
- 1: Enables address translation in support of packed mode.

1 Frame Buffer Linear Mapping Enable

- 0: Disables the linear mapping of the frame buffer.
- 1: Enables the linear mapping of the frame buffer.

0 Frame Buffer Page Mapping Enable

- 0: Disables the mapping of the frame buffer in 64KB pages into the A0000h-AFFFFh memory address space.
- 1: Enables the mapping of the frame buffer in 64KB pages into the A0000h-AFFFFh memory address space.

Note: The selection of which 64KB page is to be mapped into memory addresses A0000h-AFFFFh is made using bits 6-0 of the Frame Buffer Page Selector Register (XR0E).

XR0B PCI Burst Write Support Register

read/write at I/O address 3D7h with index at I/O address 3D6h set to 0Bh

7	6	5	4	3	2	1	0
Reserved (0000)				Font Exp Burst Write Depth (0)	PCI Burst Write Depth (0)	Reserved (0)	Burst Write Enable (0)

7-4 Reserved

These bits always return the value of 0 when read.

3 Font Expansion PCI Burst Write Buffer Depth

0: The buffer used to receive PCI burst writes is always 4 or 8 doublewords deep as selected by bit 2 of this register, regardless of whether or not font expansion is being used. This is the default after a reset.

1: The buffer used to receive PCI burst writes is limited to being 1 doubleword deep when the font expansion feature is being used.

2 PCI Burst Write Buffer Depth

0: The buffer used to receive PCI burst writes is set to be 8 doublewords deep.

1: The buffer used to receive PCI burst writes is set to be 4 doublewords deep.

Note: The use of this bit to choose the depth of the PCI burst write buffer can be overridden by bit 3 of this register.

1 Reserved

This bit always returns the value of 0 when read.

0 PCI Burst Write Support Enable

0: Disables support for receiving PCI burst write cycles.

1: Enables support for receiving PCI burst write cycles.

XR0E Frame Buffer Page Select Register

read/write at I/O address 3D7h with index at I/O address 3D6h set to 0Eh

7	6	5	4	3	2	1	0
Reserved (0)	Page Select (000:0000)						

:7 **Reserved**

This bit always returns the value of 0 when read.

6-0 **Page Select**

These seven bits select which 64KB page of the frame buffer is to be mapped into the A0000h-AFFFFh memory address space.

Note: Bit 0 of the Address Mapping Register (XR0A) must be set to 1 to enable this mapping feature.

XR20 BitBLT Configuration Register

read/write at I/O address 3D7h with index at I/O address 3D6h set to 20h

7	6	5	4	3	2	1	0
Reserved (00)		BitBLT Engine Color Depth (00)		Reserved (Writable) (00)		BitBLT Reset (0)	BitBLT Status (0)

7-6 Reserved

These bits always have the value of 0 when read.

5-4 BitBLT Engine Color Depth

When bit 23 of the BitBLT Control Register (BR04) is set to 0, these two bits configure the BitBLT engine for one of three possible color depths. If bit 23 of the BitBLT Control Register (BR04) is set to 1, then this function is performed by bits 25 and 24 of that same register. It is strongly recommended that the color depth of the BitBLT engine be set to match the color depth to which the graphics system has been set whenever possible.

Bits 5 4	BitBLT Engine Color Depth Selected
0 0	8 bits per pixel (1 byte per pixel) -- This is the default after reset.
0 1	16 bits per pixel (2 bytes per pixel)
1 0	24 bits per pixel (3 bytes per pixel)
1 1	Reserved

The choice of color depth configures the BitBLT engine to work with one, two or three bytes per pixel. This directly affects the number of bytes of graphics data that the BitBLT engine will read and write for a given number of pixels. In the case of monochrome source or pattern data, this setting directly affects the color depth into which such monochrome data will be converted during the color expansion process.

If the graphics system has been set to a color depth that is not supported by the BitBLT engine, then it is strongly recommended that the BitBLT engine not be used. See appendix B for more information.

3-2 Reserved (Writable)

These bits should always be written to with the value of 0.

1 BitBLT Reset

0: Writing a value of 0 to this bit permits normal operation of the BitBLT engine. This is the default value after reset.

1: Writing a value of 1 to this bit resets the BitBLT engine.

0 BitBLT Engine Status

0: Indicates that the BitBLT engine is idle. This is the default after reset.

1: Indicates that the BitBLT engine is busy.

XR40 Memory Access Control Register

read/write at I/O address 3D7h with index at I/O address 3D6h set to 40h

7	6	5	4	3	2	1	0
Reserved (Writable) (0000:00)						Address Wrap (0)	Memory Access (0)

7-2 Reserved (Writable)

These bits should always be set to the value of 0.

1 Address Wrap

0: Only bits 0 through 17 of the memory address decode are used, causing the memory address to wrap at 256K for all memory accesses either through the VGA porthole or linearly.

1: All memory address bits are used, allowing access to all of the graphics memory.

0 Memory Access Width

0: Selects the use of 16-bit accesses to memory to accommodate the standard VGA modes and extended resolution modes with 4-bit color. This is the default after reset.

1: Selects the use of 64-bit accesses to memory to accommodate high resolution modes.

XR41-XR4F Memory Configuration Registers

read/write at I/O address 3D7h with index at I/O address 3D6h set to 41h to 4Fh

7	6	5	4	3	2	1	0
Memory Configuration Bits (xxxx:xxxx)							

7-0 Memory Configuration Bits

The bits in each of these registers provide various ways to configure various aspects of the frame buffer.

Each of these registers defaults to a particular setting, and some of these settings are non-zero. These default settings should NEVER be changed.

XR60 Video Pin Control Register

read/write at I/O address 3D7h with index at I/O address 3D6h set to 60h

7	6	5	4	3	2	1	0
Reserved (0)	PCLK Pin Source (0)	Reserved (00:00)				Video Data Port Configuration (00)	

7 Reserved

This bit always returns the value of 0 when read.

6 Video Data Port PCLK Pin Source

0: Selects the DCLK signal as the source. This is the default after reset.

1: Selects the DCLK signal, divided by 2, as the source.

5-2 Reserved

These bits always return the value of 0 when read.

1-0 Video Data Port Configuration

00: Disables the video data port feature.

01: Enables the video data port and configures it to be used to support a standard VGA interface.

10: Reserved

11: Enables the video data port and configures it to be used to support a ZV-type feature connector.

XR61 DPMS Sync Control Register

read/write at I/O address 3D7h with index at I/O address 3D6h set to 61h

7	6	5	4	3	2	1	0
Reserved (0)	DPMS VSYNC (0)	DPMS HSYNC (0)	DPMS State Control (0)	DPMS VSYNC Sel (0)	DPMS VSYNC Data (0)	DPMS HSYNC Sel (0)	DPMS HSYNC Data (0)

- 7 Reserved**
This bit always has the value of 0 when read.
- 6 DPMS VSYNC Output Select 2**
0: The value carried by bit 2 of this register is output on the VSYNC pin. This is the default after reset.
1: The internal power sequencing clock is output on the VSYNC pin.
- 5 DPMS HSYNC Output Select 2**
0: The value carried by bit 0 of this register is output on the HSYNC pin. This is the default after reset.
1: The internal power sequencing clock is output on the HSYNC pin.
- 4 DPMS HSYNC/VSYNC State Control**
0: HSYNC and VSYNC pins are tri-stated during standby or panel-off modes. This is the default after reset.
1: HSYNC and VSYNC pins are driven during standby or panel-off modes with whatever data or signals that are selected by the other bits in this register.
- 3 DPMS VSYNC Output Select 1**
0: The VSYNC signal is output on the VSYNC pin. This is the default after reset.
1: Bit 6 of this register is used to select what is output on the VSYNC pin.
- 2 DPMS VSYNC Output Data**
The value to which this bit is set is output on the VSYNC pin if bits 6 and 3 of this register are set to 0 and 1, respectively.
- 1 DPMS HSYNC Output Select 1**
0: The HSYNC signal is output on the HSYNC pin. This is the default after reset.
1: Bit 5 of this register is used to select what is output on the HSYNC pin.
- 0 DPMS HSYNC Output Data**
The value to which this bit is set is output on the HSYNC pin if bits 5 and 1 of this register are set to 0 and 1, respectively.

XR62 GPIO Pin Control Register

read/write at I/O address 3D7h with index at I/O address 3D6h set to 62h

7	6	5	4	3	2	1	0
GPIO7 Direction (0)	Reserved (00)		GPIO4 Direction (0)	GPIO3 Direction (0)	GPIO2 Direction (0)	Reserved (00)	

Note: See the FP Pin Control 2 Register (FR0C) for direction control of GPIO0 and GPIO1.

7 GPIO7 Direction Control

0: GPIO7 acts as an input. This is the default after reset.

1: GPIO7 acts as an output.

6-5 Reserved

These bits always return the value of 0 when read.

4 GPIO4 Direction Control

0: GPIO4 acts as an input. This is the default after reset.

1: GPIO4 acts as an output.

3 GPIO3 Direction Control

0: GPIO3 acts as an input. This is the default after reset.

1: GPIO3 acts as an output.

2 GPIO2 Direction Control

0: GPIO2 acts as an input. This is the default after reset.

1: GPIO2 acts as an output.

1-0 Reserved

These bits always return the value of 0 when read.

XR63 GPIO Pin Data Register

read/write at I/O address 3D7h with index at I/O address 3D6h set to 63h

7	6	5	4	3	2	1	0
GPIO7 Data (x)	Reserved (00)		GPIO4 Data (x)	GPIO3 Data (x)	GPIO2 Data (x)	GPIO1 Data (x)	GPIO0 Data (x)

7 GPIO7 Data

This bit is used in either reading or setting the state of GPIO7.

6-5 Reserved

These bits always return the value of 0 when read.

4 GPIO4 Data

This bit is used in either reading or setting the state of GPIO4.

3 GPIO3 Data

This bit is used in either reading or setting the state of GPIO3.

2 GPIO2 Data

This bit is used in either reading or setting the state of GPIO2.

1 GPIO1 Data

This bit is used in either reading or setting the state of GPIO1.

0 GPIO0 Data

This bit is used in either reading or setting the state of GPIO0.

XR67 Pin Tri-State Control Register

read/write at I/O address 3D7h with index at I/O address 3D6h set to 67h

7	6	5	4	3	2	1	0
Reserved (0000:00)						Data Port Tri-State (0)	Reserved (0)

7-2 Reserved

These bits always return the value of 0 when read.

1 Video Data Port Tri-State

0: Video data port pins are not tri-stated. This the default after reset.

1: Video data port pins are tri-stated.

0 Reserved

This bit should always be written to with a value of zero.

XR70 Configuration Pins 0 Register

read-only at I/O address 3D7h with index at I/O address 3D6h set to 70h

7	6	5	4	3	2	1	0
CFG7 (x)	CFG6 (x)	CFG5 (x)	CFG4 (x)	CFG3 (x)	CFG2 (x)	CFG1 (x)	Reserved (1)

The bits of this register indicate the state of each of these pins at the time the graphics controller is reset.

During a reset, the graphics controller does not drive these pins, thereby allowing them to either be pulled high by relatively weak internal resistors, or to be pulled low by external resistors (4.7K recommended). Instead, during reset, the graphics controller latches the state of these pins, and the latched values are used by the graphics controller to provide a limited degree of hardware-based configuration of some features. Some of these latched values directly affect the hardware, while others are simply reflected in this register so as to be read by configuration software, usually the BIOS.

7 Pin CFG7

- 0: Enables clock test mode.
- 1: Disables clock test mode.

Note: Clock test mode allows the internal clock synthesizers to be tested, by placing the output of the MCLK synthesizer on the ROMOE# pin (the pin used to drive the chip select pin of the BIOS ROM) and the output of the VCLK synthesizer on the PCLK pin (the clock pin used for the video data port).

6 Pin CFG6

- 0: The ACTI and ENABKL outputs are forced to be tri-stated.
- 1: The ACTI and ENABKL outputs are permitted to function normally.

5 Pin CFG5

Reserved.

No interpretation has yet been assigned to the state of this bit, and the hardware does not interpret the state of the corresponding pin during reset.

4 Pin CFG4

0: The REFCLK and TCLK pins are used as inputs to receive MCLK and DCLK, respectively, from an external source.

1: MCLK and DCLK are provided by the internal clock generators.

Note: The default selection of sources for MCLK and DCLK may be individually changed by changing the settings of bits 2 and 1 of the Memory Clock Divisor Select Register (XR70). Both of those two bits also use the state of pin AA4 at reset to determine their default values.

3 Pin CFG3

Reserved.

No interpretation has yet been assigned to the state of this bit, and the hardware does not interpret the state of the corresponding pin during reset.

2 Pin CFG2

Reserved.

No interpretation has yet been assigned to the state of this bit, and the hardware does not interpret the state of the corresponding pin during reset.

1 Pin CFG1

0: Indicates that VGA I/O Address decoding is disabled on the PCI Bus, so access to the registers via I/O read and write operations is disabled.

1: Indicates that VGA I/O Address decoding is enabled on the PCI Bus, so access to the registers via I/O read and write operations is enabled.

Note: The reset state of this pin is also readable via bit 1 of the Host Bus Configuration Register (XR08).

0 Reserved

This bit always returns the value of 1 when read.

XR71 Configuration Pins 1 Register

read-only at I/O address 3D7h with index at I/O address 3D6h set to 71h

7	6	5	4	3	2	1	0
CFG15 (x)	CFG14 (x)	CFG13 (x)	CFG12 (x)	CFG11 (x)	CFG10 (x)	CFG9 (x)	CFG8 (x)

The bits of this register indicate the state of each of these pins at the time the graphics controller is reset.

During a reset, the graphics controller does not drive these pins, thereby allowing them to either be pulled high by relatively weak internal resistors, or to be pulled low by external resistors (4.7K recommended). Instead, during reset, the graphics controller latches the state of these pins, and the latched values are used by the graphics controller to provide a limited degree of hardware-based configuration of some features. Some of these latched values directly affect the hardware, while others are simply reflected in this register so as to be read by configuration software, usually the BIOS.

7 Pin CFG15

Reserved. An interpretation has not been assigned to the state of this bit, and the hardware does not interpret the state of the corresponding pin during reset.

6 Pin CFG14

Reserved for BIOS use as bit 3 of a 4-bit code specifying the panel type.

5 Pin CFG13

Reserved for BIOS use as bit 2 of a 4-bit code specifying the panel type.

4 Pin CFG12

Reserved for BIOS use as bit 1 of a 4-bit code specifying the panel type.

3 Pin CFG11

Reserved for BIOS use as bit 0 of a 4-bit code specifying the panel type.

2 Pin CFG10

Reserved. An interpretation has not been assigned to the state of this bit, and the hardware does not interpret the state of the corresponding pin during reset.

1 Pin CFG9

Reserved. An interpretation has not been assigned to the state of this bit, and the hardware does not interpret the state of the corresponding pin during reset.

0 Pin CFG8

Reserved. An interpretation has not been assigned to the state of this bit, and the hardware does not interpret the state of the corresponding pin during reset.

XR80 Pixel Pipeline Configuration 0 Register

read/write at I/O address 3D7h with index at I/O address 3D6h set to 80h

7	6	5	4	3	2	1	0
6-Bit/8-Bit DAC Select (0)	Reserved (0)	Pixel Averaging (0)	Alt Hardware Cursor En (0)	Extended Status Read (0)	Flat Panel Overscan (0)	CRT Overscan (0)	Palette Addr Select (0)

7 6-Bit/8-Bit DAC Select

0: All three D-to-A converters are set for 6-bit operation. This is the default after reset.

1: All three D-to-A converters are set for 8-bit operation.

6 Reserved

This bit always returns the value of 0 when read.

5 Pixel Averaging Enable

Pixel averaging causes the red, green and blue color component values of a replicated pixel created by the horizontal stretching process to be averaged with those of the next pixel.

0: Disables pixel averaging. This is the default after reset.

1: Enables pixel averaging.

Note: The pixel averaging feature applies only to flat panel displays, not CRT's, and it applies only when horizontal stretching is active (see the description of the Horizontal Stretching Register, FR41, for more details).

4 Alternate Hardware Cursor Enable

0: Disables hardware cursor.

1: Enables hardware cursor.

3 Extended Status Read Enable

When enabled, the extended status read feature changes the functionality of three of the palette registers in order to allow the status of the internal state machines and values of the red and green data in the input holding register to be read. The affected palette registers and their alternate functions are as follows:

0: Disable extended status read feature. This is the default after reset.

1: Enable extended status read feature.

Affected Register	Alternate Function
Pixel Data Mask Register (PALMASK)	Returns the value of the red pixel data currently in the data holding register.
Palette Write Mode Index Register (PALWX)	Returns the value of the green pixel data currently in the data holding register.
Palette State Register (PALSTATE)	Returns the status of the internal state machines in bits 7-2.

Note: This feature must be disabled to permit normal accesses to the registers and color data locations within the palette.

2 Flat Panel Overscan Color Enable

0: Disable the use of the flat panel overscan color (Overscan, bit 1). This is the default after reset.

1: Enable the use of the flat panel overscan color (Overscan, bit 1).

1 CRT Overscan Enable

0: Disable the use of the CRT overscan color (Overscan, bit 0). This is the default after reset.

1: Enable the use of the CRT overscan color (Overscan, bit 0).

0 Palette Addressing Select

0: Select the standard 256-position palette for the main display image to be accessed via the palette's sub-indexing scheme. This is the default after reset.

1: Select the separate 8-position palette for cursor 1 and cursor 2 to be accessed via the palette's sub-indexing scheme.

XR81 Pixel Pipeline Configuration 1 Register

read/write at I/O address 3D7h with index at I/O address 3D6h set to 81h

7	6	5	4	3	2	1	0
Reserved (000)			VGA Std Delay (0)	Graphics System Color Depth (0000)			

7-5 Reserved

These bits always return the value of 0 when read.

4 VGA Standard Signal Delay Enable

0: The CRT Display Enable and CRT Blank are delayed for compatibility with the VGA standard. The behavior of CR00 remains compatible with the VGA standard, inasmuch as the value placed there must be subtract by 5. This is the default after reset.

1: The CRT Display Enable and CRT Blank are not delayed. The behavior of CR00 is altered in a way that is different from the VGA standard, inasmuch as the value placed there is not to be subtracted by 5.

Note: This enables/disables the delay of signals relative to the CRT horizontal and vertical sync signals. When the flat panel display engine is enabled (i.e., when bit 1 of FR01 is set to 1), then this bit is ignored and no such delay takes place.

3-0 Graphics System Color Depth

Bits 3 2 1 0	Color Depth Selected for Graphics System
0 0 0 0	Configures the CRT pipeline for standard VGA text and graphics modes, and for 1bpp, 2bpp and 4bpp extended graphics modes. This is the default after reset.
0 0 0 1	Reserved
0 0 1 0	Configures the CRT pipeline for 8bpp extended graphics modes.
0 0 1 1	Reserved
0 1 0 0	Configures the CRT pipeline for 16bpp extended graphics modes wherein the graphics data follows a fixed Targa-compatible 5-5-5 RGB format.
0 1 0 1	Configures the CRT pipeline for 16bpp extended graphics modes wherein the graphics data follows a fixed XGA-compatible 5-6-5 RGB format.
0 1 1 0	Configures the CRT pipeline for packed 24bpp extended graphics modes wherein only 3 bytes are allocated for each pixel.
0 1 1 1	Configures the CRT pipeline for non-packed 24bpp (32bpp) extended graphics modes wherein 4 bytes are allocated for each pixel, so that the graphics data for each pixel is doubleword-aligned. The 4th byte allocated for each pixel is unused.
1 x x x	Reserved

XR82 Pixel Pipeline Configuration 2 Register

read/write at I/O address 3D7h with index at I/O address 3D6h set to 82h

7	6	5	4	3	2	1	0
Reserved (0000)				Graphics Gamma (0)	Video Gamma (0)	Comp. Sync on Green (0)	Blank Pedestal (0)

7-4 Reserved

These bits always return the value of 0 when read.

3 Graphics Data Gamma Correction Enable

0: Graphics data bypasses the palette when the graphics system is set to a color depth of 16, 24 or 32 bits per pixel. This is the default after reset.

1: Graphics data goes through the palette when the graphics system is set to a color depth of 16, 24 or 32 bits per pixel, allowing the palette to be used to perform gamma correction.

2 Video Data Gamma Correction Enable

0: Video data bypasses the palette. This is the default after reset.

1: Video data goes through the palette, allowing the palette to be used to perform gamma correction.

1 Composite Sync on Green Enable

0: Disables the provision of composite sync on the green analog output. This is the default after reset.

1: Enables the provision of composite sync on the green analog output.

0 Blank Pedestal Enable

0: Disables the provision of a pedestal output level during blanking periods. This is the default after reset.

1: Enables the provision of a pedestal output level during blanking periods.

XRA0 Cursor 1 Control Register

read/write at I/O address 3D7h with index at I/O address 3D6h set to A0h

7	6	5	4	3	2	1	0
Cursor 1 Blink En (0)	Cursor 1 V Stretch (0)	Cursor 1 H Stretch (0)	Coordinate Origin Sel (0)	Vertical Extension (0)	Cursor 1 Mode Select (000)		

7 Cursor 1 Blink Enable

- 0: Disables blinking. This is the default after reset.
- 1: Enables blinking. Blinking rate set in register FR19.

6 Cursor 1 Vertical Stretching Enable

- 0: Disables vertical stretching for cursor 1. This is the default after reset.
- 1: Enables vertical stretching for cursor 1.

Note: Just as is the case with the vertical stretching for the main display image, vertical stretching for cursor 1 applies only to flat panel displays.

5 Cursor 1 Horizontal Stretching Enable

- 0: Disables horizontal stretching for cursor 1. This is the default after reset.
- 1: Enables horizontal stretching for cursor 1.

Note: Just as is the case with the horizontal stretching for the main display image, horizontal stretching for cursor 1 applies only to flat panel displays.

4 Cursor 1 Coordinate System Origin Select

- 0: Selects the outermost upper left-hand corner of the screen border as the origin for the coordinate system used to position cursor 1. This is the default after reset.
- 1: Selects the upper left-hand corner of the active display area as the origin for the coordinate system used to position cursor 1.

3 Cursor 1 Vertical Extension Enable

- 0: Disables the vertical extension feature for cursor 1. This is the default after reset.
- 1: Enables the vertical extension feature for cursor 1, thereby permitting the height of cursor 1 may be specified independently of its mode selection through the use of the Cursor 1 Vertical Extension Register (XRA1).

2-0 Cursor 1 Mode Select

These three bits select the mode for cursor 1. See appendix F for more details concerning the cursor modes.

Bits 2 1 0	Cursor Mode
0 0 0	Cursor 1 is disabled. This is the default after reset.
0 0 1	32x32 2bpp AND/XOR 2-plane mode
0 1 0	128x128 1bpp 2-color mode
0 1 1	128x128 1bpp 1-color and transparency mode
1 0 0	64x64 2bpp 3-color and transparency mode
1 0 1	64x64 2bpp AND/XOR 2-plane mode
1 1 0	64x64 2bpp 4-color mode
1 1 1	Reserved

XRA1 Cursor 1 Vertical Extension Register

read/write at I/O address 3D7h with index at I/O address 3D6h set to A1h

7	6	5	4	3	2	1	0
Cursor 1 Vertical Extension (00h)							

7-0 Cursor 1 Vertical Extension

When the vertical extension feature for cursor 1 is enabled by setting bit 3 of the Cursor 1 Control Register (XRA0) to 1, these 8 bits of this register are used to specify the height of cursor 1 in scan lines. The number of scan lines must be a multiple of four.

This register should be programmed with a value derived from the following equation:

$$\text{value} = ((\text{number of scanlines}) \div (4) - 1)$$

XRA2 Cursor 1 Base Address Low Register

read/write at I/O address 3D7h with index at I/O address 3D6h set to A2h

7	6	5	4	3	2	1	0
Cursor 1 Base Address Bits 15-12 (0000)				Cursor 1 Pattern Select (0000)			

7-4 Cursor 1 Base Address Bits 15-12

These four bits provide part of a 22-bit value that specifies the offset from the beginning of the frame buffer memory space where the 4KB cursor data space for cursor 1 is to be located. The six most-significant bits of this 22-bit value are supplied by the Cursor 1 Base Address High Register (XRA3).

3-0 Cursor 1 Pattern Select

These four bits allow 1 of up to as many as 16 possible patterns contained in the cursor data space for cursor 1 to be selected to be displayed. The actual number of patterns depends on the size of each pattern, since the cursor data space is limited to a total of 4KB in size. The size of each pattern depends, at least in part, on the choice of cursor mode. See appendix D for more details concerning the cursor modes.

XRA3 Cursor 1 Base Address High Register

read/write at I/O address 3D7h with index at I/O address 3D6h set to A3h

7	6	5	4	3	2	1	0
Reserved (00)		Cursor 1 Base Address Bits 21-16 (00:0000)					

7-6 Reserved

These bits always return the value of 0 when read.

5-0 Cursor 1 Base Address Bits 21-16

These six bits provide the six most significant bits of a 22-bit value that specifies the offset from the beginning of the frame buffer memory space where the 4KB cursor data space for cursor 1 is to be located. The four next most-significant bits of this 22-bit value are supplied by the Cursor 1 Base Address Low Register (XRA2).

XRA4 Cursor 1 X-Position Low Register

read/write at I/O address 3D7h with index at I/O address 3D6h set to A4h

7	6	5	4	3	2	1	0
Cursor 1 X-Position Magnitude Bits 7-0 (00h)							

7-0 Cursor 1 X-Position Magnitude Bits 7-0

This register provides the eight least significant magnitude bits of a signed 12-bit value that specifies the horizontal position of cursor 1. The three most significant magnitude bits and the sign bit of this value are provided by bits 2-0 and bit 7, respectively, of the Cursor 1 X-Position High Register (XRA5).

XRA5 Cursor 1 X-Position High Register

read/write at I/O address 3D7h with index at I/O address 3D6h set to A5h

7	6	5	4	3	2	1	0
X-Pos Sign Bit (0)	Reserved (000:0)				Cursor 1 X-Position Magnitude Bits 10-8 (000)		

7 Cursor 1 X-Position Sign Bit

This bit provides the sign bit of a signed 12-bit value that specifies the horizontal position of cursor 1. The magnitude bits are provided by the Cursor 1 X-Position Low Register (XRA4) and bits 2-0 of this register.

6-3 Reserved

These bits always return the value of 0 when read.

2-0 Cursor 1 X-Position Magnitude Bits 10-8

These three bits provide the three most significant magnitude bits of a signed 12-bit value that specifies the horizontal position of cursor 1. The eight least significant magnitude bits of this value are provided by bits 7-0 of the Cursor 1 X-Position Low Register (XRA4). The sign bit is provided by bit 7 of this register.

XRA6 Cursor 1 Y-Position Low Register

read/write at I/O address 3D7h with index at I/O address 3D6h set to A6h

7	6	5	4	3	2	1	0
Cursor 1 Y-Position Magnitude Bits 7-0 (00h)							

7-0 Cursor 1 Y-Position Magnitude Bits 7-0

This register provides the eight least significant magnitude bits of a signed 12-bit value that specifies the vertical position of cursor 1. The three most significant magnitude bits and the sign bit of this value are provided by bits 2-0 and bit 7, respectively, of the Cursor 1 Y-Position High Register (XRA7).

XRA7 Cursor 1 Y-Position High Register

read/write at I/O address 3D7h with index at I/O address 3D6h set to A7h

7	6	5	4	3	2	1	0
Y-Pos Sign Bit (0)	Reserved (000:0)			Cursor 1 Y-Position Magnitude Bits 10-8 (000)			

7 Cursor 1 Y-Position Sign Bit

This bit provides the sign bit of a signed 12-bit value that specifies the horizontal position of cursor 1. The magnitude bits are provided by the Cursor 1 Y-Position Low Register (XRA6) and bits 2-0 of this register.

6-3 Reserved

These bits always return the value 0 when read.

2-0 Cursor 1 Y-Position Magnitude Bits 10-8

These three bits provide the three most significant magnitude bits of a signed 12-bit value that specifies the vertical position of cursor 1. The eight least significant magnitude bits of this value are provided by bits 7-0 of the Cursor 1 Y-Position Low Register (XRA6). The sign bit is provided by bit 7 of this register.

XRA8 Cursor 2 Control Register

read/write at I/O address 3D7h with index at I/O address 3D6h set to A8h

7	6	5	4	3	2	1	0
Cursor 2 Blink En (0)	Cursor 2 V Stretch (0)	Cursor 2 H Stretch (0)	Coordinate Origin Sel (0)	Vertical Extension (0)	Cursor 2 Mode Select (000)		

7 Cursor 2 Blink Enable

- 0: Disables blinking. This is the default after reset.
- 1: Enables blinking. Blinking rate set in register FR19.

6 Cursor 2 Vertical Stretching Enable

- 0: Disables vertical stretching for cursor 2. This is the default after reset.
- 1: Enables vertical stretching for cursor 2.

Note: Just as is the case with the vertical stretching for the main display image, vertical stretching for cursor 2 applies only to flat panel displays.

5 Cursor 2 Horizontal Stretching Enable

- 0: Disables horizontal stretching for cursor 2. This is the default after reset.
- 1: Enables horizontal stretching for cursor 2.

Note: Just as is the case with the horizontal stretching for the main display image, horizontal stretching for cursor 2 applies only to flat panel displays.

4 Cursor 2 Coordinate System Origin Select

- 0: Selects the outermost upper left-hand corner of the screen border as the origin for the coordinate system used to position cursor 2. This is the default after reset.
- 1: Selects the upper left-hand corner of the active display area as the origin for the coordinate system used to position cursor 2.

3 Cursor 2 Vertical Extension Enable

- 0: Disables the vertical extension feature for cursor 2. This is the default after reset.
- 1: Enables the vertical extension feature for cursor 2, thereby permitting the height of cursor 2 may be specified independently of its mode selection through the use of the Cursor 2 Vertical Extension Register (XRA9).

2-0 Cursor 2 Mode Select

These three bits select the mode for cursor 2. See appendix F for more details concerning the cursor modes.

Bits 2 1 0	Cursor Mode
0 0 0	Cursor 2 is disabled. This is the default after reset.
0 0 1	32x32 2bpp AND/XOR 2-plane mode
0 1 0	128x128 1bpp 2-color mode
0 1 1	128x128 1bpp 1-color and transparency mode
1 0 0	64x64 2bpp 3-color and transparency mode
1 0 1	64x64 2bpp AND/XOR 2-plane mode
1 1 0	64x64 2bpp 4-color mode
1 1 1	Reserved

XRA9 Cursor 2 Vertical Extension Register

read/write at I/O address 3D7h with index at I/O address 3D6h set to A9h

7	6	5	4	3	2	1	0
Cursor 2 Vertical Extension (00h)							

7-0 Cursor 2 Vertical Extension

When the vertical extension feature for cursor 2 is enabled by setting bit 3 of the Cursor 2 Control Register (XRA8) to 1, these 8 bits of this register are used to specify the height of cursor 2 in scan lines. The number of scan lines must be a multiple of four.

This register should be programmed with a value derived from the following equation:

$$\text{value} = ((\text{number of scanlines}) \div (4) - 1)$$

XRAA Cursor 2 Base Address Low Register

read/write at I/O Address 3D7h with index at I/O address 3D6h set to AAh

7	6	5	4	3	2	1	0
Cursor 2 Base Address Bits 15-12 (0000)				Cursor 2 Pattern Select (0000)			

7-4 Cursor 2 Base Address Bits 15-12

These four bits provide part of a 22-bit value that specifies the offset from the beginning of the frame buffer memory space where the 4KB cursor data space for cursor 2 is to be located. The six most-significant bits of this 22-bit value are supplied by the Cursor 2 Base Address High Register (XRAB).

3-0 Cursor 2 Pattern Select

These four bits allow 1 of up to as many as 16 possible patterns contained in the cursor data space for cursor 2 to be selected to be displayed. The actual number of patterns depends on the size of each pattern, since the cursor data space is limited to a total of 4KB in size. The size of each pattern depends, at least in part, on the choice of cursor mode. See the section on the hardware cursor and popup for more details concerning the cursor modes.

XRAB Cursor 2 Base Address High Register

read/write at I/O address 3D7h with index at I/O address 3D6h set to ABh

7	6	5	4	3	2	1	0
Reserved (00)		Cursor 2 Base Address Bits 21-16 (00:0000)					

7-6 Reserved

These bits always return the value of 0 when read.

5-0 Cursor 2 Base Address Bits 21-16

These six bits provide the six most significant bits of a 22-bit value that specifies the offset from the beginning of the frame buffer memory space where the 4KB cursor data space for cursor 2 is to be located. The four next most-significant bits of this 22-bit value are supplied by the Cursor 2 Base Address Low Register (XRAA).

XRAC Cursor 2 X-Position Low Register

read/write at I/O address 3D7h with index at I/O address 3D6h set to ACh

7	6	5	4	3	2	1	0
Cursor 2 X-Position Magnitude Bits 7-0 (00h)							

7-0 Cursor 2 X-Position Magnitude Bits 7-0

This register provides the eight least significant magnitude bits of a signed 12-bit value that specifies the horizontal position of cursor 2. The three most significant magnitude bits and the sign bit of this value are provided by bits 2-0 and bit 7, respectively, of the Cursor 2 X-Position High Register (XRAD).

XRAD Cursor 2 X-Position High Register

read/write at I/O address 3D7h with index at I/O address 3D6h set to ADh

7	6	5	4	3	2	1	0
X-Position Sign Bit (0)	Reserved (000:0)			Cursor 2 X-Position Magnitude Bits 10-8 (000)			

7 Cursor 2 X-Position Sign Bit

This bit provides the sign bit of a signed 12-bit value that specifies the horizontal position of cursor 2. The magnitude bits are provided by the Cursor 2 X-Position Low Register (XRAC) and bits 2-0 of this register.

6-3 Reserved

These bits always return the value of 0 when read.

2-0 Cursor 2 X-Position Magnitude Bits 10-8

These three bits provide the three most significant magnitude bits of a signed 12-bit value that specifies the horizontal position of cursor 2. The eight least significant magnitude bits of this value are provided by bits 7-0 of the Cursor 2 X-Position Low Register (XRAC). The sign bit is provided by bit 7 of this register.

XRAE Cursor 2 Y-Position Low Register

read/write at I/O address 3D7h with index at I/O address 3D6h set to AEh

7	6	5	4	3	2	1	0
Cursor 2 Y-Position Magnitude Bits 7-0 (00h)							

7-0 Cursor 2 Y-Position Magnitude Bits 7-0

This register provides the eight least significant magnitude bits of a signed 12-bit value that specifies the vertical position of cursor 2. The three most significant magnitude bits and the sign bit of this value are provided by bits 2-0 and bit 7, respectively, of the Cursor 2 Y-Position High Register (XRAF).

XRAF Cursor 2 Y-Position High Register

read/write at I/O address 3D7h with index at I/O address 3D6h set to AFh

7	6	5	4	3	2	1	0
Y-Position Sign Bit (0)	Reserved (000:0)				Cursor 2 Y-Position Magnitude Bits 10-8 (000)		

7 Cursor 2 Y-Position Sign Bit

This bit provides the sign bit of a signed 12-bit value that specifies the vertical position of cursor 2. The magnitude bits are provided by the Cursor 2 Y-Position Low Register (XRAE) and bits 2-0 of this register.

6-3 Reserved

These bits always return the value of 0 when read.

2-0 Cursor 2 Y-Position Magnitude Bits 10-8

These three bits provide the three most significant magnitude bits of a signed 12-bit value that specifies the vertical position of cursor 2. The eight least significant magnitude bits of this value are provided by bits 7-0 of the Cursor 2 Y-Position Low Register (XRAE). The sign bit is provided by bit 7 of this register.

XRC0 Dot Clock 0 VCO M-Divisor Register

read/write at I/O address 3D7h with index at I/O address 3D6h set to C0h

7	6	5	4	3	2	1	0
Dot Clock 0 VCO M-Divisor							

Note: All four of the registers used in specifying the loop parameters for dot clock 0 (XRC0 - XRC3) must be written, and in order from XRC0 to XRC3, before the hardware will update the synthesizer's settings. This is a form of double-buffering that is intended to prevent fluctuations in the synthesizer's output as new values are being written to these registers.

7-0 Dot Clock 0 VCO M-Divisor

This register provides the M-divisor, one of the loop parameters used in controlling the frequency of the output of the synthesizer used to generate dot clock 0. A series of calculations are used to derive this value and the values for the other loop parameters given a desired output frequency and a series of constraints placed on different components within the synthesizer used to generate dot clock 0. See appendix B for a detailed description of the process used to derive the loop parameter values.

XRC1 Dot Clock 0 VCO N-Divisor Register

read/write at I/O address 3D7h with index at I/O address 3D6h set to C1h

7	6	5	4	3	2	1	0
Dot Clock 0 VCO N-Divisor							

Note: All four of the registers used in specifying the loop parameters for dot clock 0 (XRC0 - XRC3) must be written, and in order from XRC0 to XRC3, before the hardware will update the synthesizer's settings. This is a form of double-buffering that is intended to prevent fluctuations in the synthesizer's output as new values are being written to these registers.

7-0 Dot Clock 0 VCO N-Divisor Bits 7-0

This register provides the N-divisor, one of the loop parameters used in controlling the frequency of the output of the synthesizer used to generate dot clock 0.

A series of calculations are used to derive this value and the values for the other loop parameters given a desired output frequency and a series of constraints placed on different components within the synthesizer used to generate dot clock 0. See appendix B for a detailed description of the process used to derive the loop parameter values.

XRC3 Dot Clock 0 Divisor Select Register

read/write at I/O address 3D7h with index at I/O address 3D6h set to C3h

7	6	5	4	3	2	1	0
Reserved	Post Divisor Select			Reserved	VCO Loop Divisor	Reserved	

Note: All four of the registers used in specifying the loop parameters for dot clock 0 (XRC0 - XRC3) must be written, and in order from XRC0 to XRC3, before the hardware will update the synthesizer's settings. This is a form of double-buffering that is intended to prevent fluctuations in the synthesizer's output as new values are being written to these registers.

7 Reserved

This bit always returns the value of 0 when read.

6-4 Post Divisor Select

These three bits select a value that specifies the post divisor, one of the loop parameters used in controlling the frequency of the output of the synthesizer used to generate dot clock 0. The manner in which these bits are used to choose this value is shown in the table below:

Bits 6 5 4	Post Divisor
0 0 0	1
0 0 1	2
0 1 0	4
0 1 1	8
1 0 0	16
1 0 1	32
1 1 0	Reserved
1 1 1	Reserved

A series of calculations are used to derive this value and the values for the other loop parameters given a desired output frequency and a series of constraints placed on different components within the synthesizer used to generate dot clock 0. See the appendix B for a detailed description of the process used to derive the loop parameter values.

3 Reserved

This bit always returns the value of 0 when read.

2 VCO Loop Divisor Select

This bit selects a value that specifies the VCO loop divide, one of the loop parameters used in controlling the frequency of the output of the synthesizer used to generate dot clock 0.

0: Selects a VCO loop divide value of 4.

1: Selects a VCO loop divide value of 1.

A series of calculations are used to derive this value and the values for the other loop parameters given a desired output frequency and a series of constraints placed on different components within the synthesizer used to generate dot clock 0. See appendix B for a detailed description of the process used to derive the loop parameter values.

1-0 Reserved

These bits always return the value 0 when read.

XRC4Dot Clock 1 VCO M-Divisor Register

read/write at I/O address 3D7h with index at I/O address 3D6h set to C4h

7	6	5	4	3	2	1	0
Dot Clock 1 VCO M-Divisor							

Note: All four of the registers used in specifying the loop parameters for dot clock 1 (XRC4 - XRC7) must be written, and in order, from XRC4 to XRC7 before the hardware will update the synthesizer's settings. This is a form of double-buffering that is intended to prevent fluctuations in the synthesizer's output as new values are being written to these registers.

7-0 Dot Clock 1 VCO M-Divisor

This register the M-divisor, one of the loop parameters used in controlling the frequency of the output of the synthesizer used to generate dot clock 1.

A series of calculations are used to derive this value and the values for the other loop parameters given a desired output frequency and a series of constraints placed on different components within the synthesizer used to generate dot clock 1. See appendix B for a detailed description of the process used to derive the loop parameter values.

XRC5 Dot Clock 1 VCO N-Divisor Register

read/write at I/O address 3D7h with index at I/O address 3D6h set to C5h

7	6	5	4	3	2	1	0
Dot Clock 1 VCO N-Divisor Bits 7-0							

Note: All four of the registers used in specifying the loop parameters for dot clock 1 (XRC4 - XRC7) must be written, and in order from XRC4 to XRC7, before the hardware will update the synthesizer's settings. This is a form of double-buffering that is intended to prevent fluctuations in the synthesizer's output as new values are being written to these registers.

7-0 Dot Clock 1 VCO N-Divisor Bits 7-0

This register provides the N-divisor, one of the loop parameters used in controlling the frequency of the output of the synthesizer used to generate dot clock 1.

A series of calculations are used to derive this value and the values for the other loop parameters given a desired output frequency and a series of constraints placed on different components within the synthesizer used to generate dot clock 1. See appendix B for a detailed description of the process used to derive the loop parameter values.

XRC7 Dot Clock 1 Divisor Select Register

read/write at I/O address 3D7h with index at I/O address 3D6h set to Index C7h

7	6	5	4	3	2	1	0
Reserved	Post Divisor Select			Reserved	VCO Loop Divisor	Reserved	

Note: All four of the registers used in specifying the loop parameters for dot clock 1 (XRC4 - XRC7) must be written, and in order from XRC4 to XRC7, before the hardware will update the synthesizer's settings. This is a form of double-buffering that is intended to prevent fluctuations in the synthesizer's output as new values are being written to these registers.

7 Reserved

This bit always returns the value of 0 when read.

6-4 Post Divisor Select

These three bits select a value that specifies the post divisor, one of the loop parameters used in controlling the frequency of the output of the synthesizer used to generate dot clock 1. The manner in which these bits are used to choose this value is shown in the table below:

Bits 6 5 4	Post Divisor
0 0 0	1
0 0 1	2
0 1 0	4
0 1 1	8
1 0 0	16
1 0 1	32
1 1 0	Reserved
1 1 1	Reserved

A series of calculations are used to derive this value and the values for the other loop parameters given a desired output frequency and a series of constraints placed on different components within the synthesizer used to generate dot clock 0. See appendix B for a detailed description of the process used to derive the loop parameter values.

3 Reserved

This bit always returns the value of 0 when read.

2 VCO Loop Divisor Select

This bit selects a value that specifies the VCO loop divide, one of the loop parameters used in controlling the frequency of the output of the synthesizer used to generate dot clock 1.

0: Selects a VCO loop divide value of 4.

1: Selects a VCO loop divide value of 1.

A series of calculations are used to derive this value and the values for the other loop parameters given a desired output frequency and a series of constraints placed on different components within the synthesizer used to generate dot clock 1. See appendix B for a detailed description of the process used to derive the loop parameter values.

1-0 Reserved

These bits always return the value 0 when read.

XRC8 Dot Clock 2 VCO M-Divisor Register

read/write at I/O address 3D7h with index at I/O address 3D6h set to C8h

7	6	5	4	3	2	1	0
Dot Clock 2 VCO M-Divisor							

Note: All four of the registers used in specifying the loop parameters for dot clock 2 (XRC8 - XRCB) must be written, and in order from XRC8 to XRCB, before the hardware will update the synthesizer's settings. This is a form of double-buffering that is intended to prevent fluctuations in the synthesizer's output as new values are being written to these registers.

7-0 Dot Clock 2 VCO M-Divisor

This register provides the M-divisor, one of the loop parameters used in controlling the frequency of the output of the synthesizer used to generate dot clock 2.

A series of calculations are used to derive this value and the values for the other loop parameters given a desired output frequency and a series of constraints placed on different components within the synthesizer used to generate dot clock 2. See appendix B for a detailed description of the process used to derive the loop parameter values.

XRC9 Dot Clock 2 VCO N-Divisor Register

read/write at I/O address 3D7h with index at I/O address 3D6h set to C9h

7	6	5	4	3	2	1	0
Dot Clock 2 VCO N-Divisor							

Note: All four of the registers used in specifying the loop parameters for dot clock 2 (XRC8 - XRCB) must be written, and in order from XRC8 to XRCB, before the hardware will update the synthesizer's settings. This is a form of double-buffering that is intended to prevent fluctuations in the synthesizer's output as new values are being written to these registers.

7-0 Dot Clock 2 VCO N-Divisor Bits 7-0

This register provides the N-divisor, one of the loop parameters used in controlling the frequency of the output of the synthesizer used to generate dot clock 2.

A series of calculations are used to derive this value and the values for the other loop parameters given a desired output frequency and a series of constraints placed on different components within the synthesizer used to generate dot clock 2. See appendix B for a detailed description of the process used to derive the loop parameter values.

XRCB Dot Clock 2 Divisor Select Register

read/write at I/O address 3D7h with index at I/O address 3D6h set to CBh

7	6	5	4	3	2	1	0
Reserved	Post Divisor Select			Reserved	VCO Loop Divisor	Reserved	

Note: All four of the registers used in specifying the loop parameters for dot clock 2 (XRC8 - XRCB) must be written, and in order from XRC8 to XRCB, before the hardware will update the synthesizer's settings. This is a form of double-buffering that is intended to prevent fluctuations in the synthesizer's output as new values are being written to these registers.

7 Reserved

This bit always returns the value of 0 when read.

6-4 Post Divisor Select

These three bits select a value that specifies the post divisor, one of the loop parameters used in controlling the frequency of the output of the synthesizer used to generate dot clock 2. The manner in which these bits are used to choose this value is shown in the table below:

Bits 6 5 4	Post Divisor
0 0 0	1
0 0 1	2
0 1 0	4
0 1 1	8
1 0 0	16
1 0 1	32
1 1 0	Reserved
1 1 1	Reserved

A series of calculations are used to derive this value and the values for the other loop parameters given a desired output frequency and a series of constraints placed on different components within the synthesizer used to generate dot clock 2. See appendix B for a detailed description of the process used to derive the loop parameter values.

3 Reserved

This bit always returns the value of 0 when read.

2 VCO Loop Divisor Select

This bit selects a value that specifies the VCO loop divide, one of the loop parameters used in controlling the frequency of the output of the synthesizer used to generate dot clock 2.

0: Selects a VCO loop divide value of 4.

1: Selects a VCO loop divide value of 1.

A series of calculations are used to derive this value and the values for the other loop parameters given a desired output frequency and a series of constraints placed on different components within the synthesizer used to generate dot clock 2. See appendix B for a detailed description of the process used to derive the loop parameter values.

1-0 Reserved

These bits always return the value of 0 when read.

XRCC Memory Clock VCO M-Divisor Register

read/write at I/O address 3D7h with index at I/O address 3D6h set to CCh

7	6	5	4	3	2	1	0
Memory Clock VCO M-Divisor							

Note: All three of the registers used in specifying the loop parameters for the memory clock (XRCC - XRCE) must be written, and in order from XRCC to XRCE, before the hardware will update the synthesizer's settings. This is a form of double-buffering that is intended to prevent fluctuations in the synthesizer's output as new values are being written to these registers.

7-0 Memory Clock VCO M-Divisor

These eight bits specify the M-divisor, one of the loop parameters used in controlling the frequency of the output of the synthesizer used to generate the memory clock.

A series of calculations are used to derive this value and the values for the other loop parameters given a desired output frequency and a series of constraints placed on different components within the synthesizer used to generate the memory clock. See appendix B for a detailed description of the process used to derive the loop parameter values.

XRCD Memory Clock VCO N-Divisor Register

read/write at I/O address 3D7h with index at I/O address 3D6h set to CDh

7	6	5	4	3	2	1	0
Memory Clock VCO N-Divisor							

Note: All three of the registers used in specifying the loop parameters for the memory clock (XRCC - XRCE) must be written, and in order from XRCC to XRCE, before the hardware will update the synthesizer's settings. This is a form of double-buffering that is intended to prevent fluctuations in the synthesizer's output as new values are being written to these registers.

7-0 Memory Clock VCO N-Divisor

These eight bits specify the N-divisor, one of the loop parameters used in controlling the frequency of the output of the synthesizer used to generate the memory clock.

A series of calculations are used to derive this value and the values for the other loop parameters given a desired output frequency and a series of constraints placed on different components within the synthesizer used to generate the memory clock. See appendix B for a detailed description of the process used to derive the loop parameter values.

XRCE Memory Clock Divisor Select Register

read/write at I/O address 3D7h with index at I/O address 3D6h set to CEh

7	6	5	4	3	2	1	0
Memory Clock Select	Post Divisor Select			Reserved			

Note: Before any value is written to bits other than bit 7 of register, bit 7 of this register should be set to 0 to select the default memory clock.

Note: All three of the registers used in specifying the loop parameters for the memory clock (XRCC - XRCE) must be written, and in order from XRCC to XRCE, before the hardware will update the synthesizer's settings. This is a form of double-buffering that is intended to prevent fluctuations in the synthesizer's output as new values are being written to these registers.

7 Memory Clock Select

0: The memory clock output is set to a preset frequency of 40.00MHz. This is the default after reset.

1: The memory clock output is controlled by the loop parameters given to the memory clock synthesizer using a group of three registers (XRCC-XRCE) which includes this one.

6-4 Post Divisor Select

These three bits select a value that specifies the post divisor, one of the loop parameters used in controlling the frequency of the output of the synthesizer used to generate the memory clock. The manner in which these bits are used to choose this value is shown in the table below:

Bits 6 5 4	Post Divisor
0 0 0	1
0 0 1	2
0 1 0	4
0 1 1	8
1 0 0	16
1 0 1	32
1 1 0	Reserved
1 1 1	Reserved

A series of calculations are used to derive this value and the values for the other loop parameters given a desired output frequency and a series of constraints placed on different components within the synthesizer used to generate the memory clock. See the appendix on clock generation for a detailed description of the process used to derive the loop parameter values.

3-0 Reserved

These bits always return the value of 0 when read.

XRCF Clock Configuration Register

read/write at I/O address 3D7h with index at I/O address 3D6h set to CFh

7	6	5	4	3	2	1	0
Reserved (0000)				Power Seq Ref Clock (0)	Dot Clock Source (x)	Mem Clk Source (x)	Reserved (0)

Note: The default values of some of the bits of this register are determined by the settings of some of the strapping pins at reset.

7-4 Reserved

These bits always return the value of 0 when read.

3 Power Sequencing Reference Clock Select

0: The clock used to time the steps of panel powerdown or powerup is the reference input clock divided by 384. Presuming that the reference clock is the usual 14.31818MHz, the frequency resulting from this division should be 37.5KHz. This is the default after reset.

1: The clock used to time the steps of panel powerdown or powerup is the 32KHz clock provided as an input on one of the GPIO pins. This same clock is usually also used to provide a time base for memory refreshes during standby mode.

2 Dot Clock Source

0: An external clock source received through the TCLK pin is used to provide the dot clock. All three of the synthesizers otherwise used to generate the three selectable dot clocks are disabled.

1: The three synthesizers used to generate the three selectable dot clocks are enabled.

Note: The default state of this bit reflects the state of pin AA4 during reset. The state of pin AA4 during reset is also readable via bit 4 of the Configuration Pins 0 Register (XR70). Bit 4 of XR70 is read-only, while this bit is writable, allowing the source of the dot clock to be changed after reset.

1 Memory Clock Source

0: An external clock source is used to provide the memory clock. The synthesizer otherwise used to generate the memory clock is disabled. The graphics controller is configured to receive this external clock source on either one of two pins depending on the state of pin AA4 during reset. If AA4 was pulled low by an external pull-down resistor during reset, then the graphics controller will be configured to receive the external clock on the REFCLK pin. If AA4 was allowed to be pulled high by the internal pull-up resistor during reset, then the graphics controller is configured to receive the external clock on the TDI pin.

1: The synthesizer used to generate memory clock is enabled.

Note: The default state of this bit reflects the state of pin AA4 during reset. The state of pin AA4 during reset is also readable via bit 4 of the Configuration Pins 0 Register (XR70). Bit 4 of XR70 is read-only, while this bit is writable, allowing the source of the memory clock to be changed after reset.

0 Reserved

This bit always returns the value of 0 when read.

XRD0 Powerdown Control Register

read/write at I/O address 3D7h with index at I/O address 3D6h set to D0h

7	6	5	4	3	2	1	0
Reserved (0)	Video Port Enable (0)	Capture Enable (1)	Playback Enable (1)	MCLK VCO Enable (1)	DCLK VCO Enable (1)	Palette Enable (1)	DAC Enable (1)

7 Reserved

This bit always returns the value of 0 when read.

6 Video Port Enable

0: Disables the video port. This is the default after reset.
1: Enables the video port.

5 Video Capture Enable

0: Disables video capture.
1: Enables video capture. This is the default after reset.

4 Video Playback Enable

0: Disables video playback.
1: Enables video playback. This is the default after reset.

3 Memory Clock VCO Enable

0: Disables the memory clock VCO.
1: Enables the memory clock VCO. This is the default after reset.

2 Dot Clock VCO Enable

0: Disables the dot clock VCO.
1: Enables the dot clock VCO. This is the default after reset.

1 Palette Enable

0: Disables the palette.
1: Enables the palette. This is the default after reset.

0 D-to-A Converters Enable

0: Disables the D-to-A converters.
1: Enables the D-to-A converters. This is the default after reset.

XRD1 Power Conservation Control Register

read/write at I/O address 3D7h with index at I/O address 3D6h set to D1h

7	6	5	4	3	2	1	0
Reserved (0000:000)							BitBLT Idle Powerdown (0)

7-1 Reserved

This bit always returns the value of 0 when read.

0 BitBLT Engine Idle-State Powerdown

0: Does not cause the BitBLT engine to automatically powerdown when idle.

1: Causes the BitBLT engine to automatically powerdown when idle.

Note: Use of this feature in no way affects usability of the BitBLT engine, and in no way impedes access to the BitBLT registers. The manner in which the BitBLT engine is programmed is not affected by the use of this feature.

XRD2 2KHz Down Counter Register

read/write at I/O address 3D7h with index at I/O address 3D6h set to D2h

7	6	5	4	3	2	1	0
32KHz Down Counter (00h)							

7-0 2KHz Down Counter

This register provides the output of a looping 8-bit counter that is continuously de-incremented at a rate of 2KHz. The 2KHz frequency is derived from the same 14.318MHz reference frequency received from an external oscillator that is used as the base frequency for the generation of both the dot clock and memory clock.

This register is meant to be used to provide a fixed time base that can be used by CHIPS' BIOS to properly time the various steps to perform a powerdown or powerup of the graphics controller.

XRE0-XREB Software Flag Registers 0 to B

read/write at I/O address 3D7h with index at I/O address 3D6h set to E0h to E0h

7	6	5	4	3	2	1	0
Software Flag Bits (xxxx:xxxx)							

7-0 Software Flag Bits

The bits in each of these twelve registers are used largely as a “scratch pad” by CHIPS’ BIOS. To a limited extent, these registers are also used as a medium of communication between CHIPS’ BIOS and CHIPS’ device drivers for various operating system environments.

XRF8-XRFC Test Registers

read/write at I/O address 3D7h with index at I/O address 3D6h set to F8h to FCh

7	6	5	4	3	2	1	0
Test Register Bits (xxxx:xxxx)							

7-0 Test Register Bits

The bits in each of these registers are used to perform chip testing, and should never be written to.

Chapter 15

Flat Panel Registers

Table 15-1: Flat Panel Registers

Name	Register Function	Access Via Port 3D1h	Index Value Port 3D0h
FR00	Feature Register	read-only	00h
FR01	CRT / FP Control Register	read/write	01h
FR02	FP Mode Control Register	read/write	02h
FR03	FP Dot Clock Source Register	read/write	03h
FR04	Panel Power Sequencing Delay Register	read/write	04h
FR05	Power Down Control 1 Register	read/write	05h
FR06	FP Power Down Control Register	read/write	06h
FR08	FP Pin Polarity Register	read/write	08h
FR0A	Programmable Output Drive Register	read/write	0Ah
FR0B	FP Pin Control 1 Register	read/write	0Bh
FR0C	Pin Control 2 Register	read/write	0Ch
FR0F	Activity Timer Control Register	read/write	0Fh
FR10	FP Format 0 Register	read/write	10h
FR11	FP Format 1 Register	read/write	11h
FR12	FP Format 2 Register	read/write	12h
FR13	FP Format 3 Register	read/write	13h
FR16	FRC Option Select Register	read/write	16h
FR17	Polynomial FRC Control Register	read/write	17h
FR18	FP Text Mode Control Register	read/write	18h
FR19	Blink Rate Control Register	read/write	19h
FR1A	STN-DD Buffering Control Register	read/write	1Ah
FR1E	M (ACDCLK) Control Register	read/write	1Eh
FR1F	Diagnostic Register	read/write	1Fh
FR20	FP Horizontal Panel Display Size LSB Register	read/write	20h
FR21	FP Horizontal Sync Start LSB Register	read/write	21h
FR22	FP Horizontal Sync End Register	read/write	22h
FR23	FP Horizontal Total LSB Register	read/write	23h
FR24	FP HSync (LP) Delay LSB Register	read/write	24h
FR25	FP Horizontal Overflow 1 Register	read/write	25h
FR26	FP Horizontal Overflow 2 Register	read/write	26h
FR27	FP HSync (LP) Width and Disable Register	read/write	27h
FR30	FP Vertical Panel Size LSB Register	read/write	30h
FR31	FP Vertical Sync Start LSB Register	read/write	31h
FR32	FP Vertical Sync End Register	read/write	32h
FR33	FP Vertical Total LSB Register	read/write	33h
FR34	FP VSync (FLM) Delay LSB Register	read/write	34h
FR35	FP Vertical Overflow 1 Register	read/write	35h
FR36	FP Vertical Overflow 2 Register	read/write	36h
FR37	FP VSync (FLM) Disable Register	read/write	37h
FR40	Horizontal Compensation Register	read/write	40h
FR41	Horizontal Stretching Register	read/write	41h
FR48	Vertical Compensation Register	read/write	48h
FR49-4C	Text Mode Vertical Stretching Register	read/write	49h-4Ch
FR4D	Vertical Line Replication Register	read/write	4Dh
FR4E	Selective Vertical Stretching Disable Register	read/write	4Eh
FR70	TMED Red Seed Register	read/write	70h
FR71	TMED Green Seed Register	read/write	71h
FR72	TMED Blue Seed Register	read/write	72h
FR73	TMED Control Register	read/write	73h
FR74	TMED2 Shift Control Register	read/write	74h

FR00 Feature Register

read-only at I/O address 3D1h with index at I/O address 3D0hh set to 00h

7	6	5	4	3	2	1	0
Reserved					H/W Pop-up	Reserved	Flat Panel

7-3 Reserved (0000-0)

2 Hardware Pop-up

- 0: Hardware support for pop-up menu does not exist
- 1: Hardware support for pop-up menu exists

1 Reserved (0)

0 Flat Panel

- 0: Flat Panel module does not exist
- 1: Flat Panel module exists

FR01 CRT / FP Control Register

read/write at I/O address 3D1h with index at I/O address 3D0hh set to 01h

7	6	5	4	3	2	1	0
Reserved (R/W)						CRT/FP Control	

7-2 Reserved (R/W) (0000-00)

1-0 CRT/FP Control

Bits 1 0	CRT/FP Control
0 0	CRT & FP display engines disabled.
0 1	CRT mode enabled. (Default)
1 0	FP mode enabled.
1 1	Reserved.

FR02 FP Mode Control Register

read/write at I/O address 3D1h with index at I/O address 3D0h set to 02h

7	6	5	4	3	2	1	0
Reserved (R/W)				Reserved			

7-4 Reserved (R/W) (reset state: 0000)

3-0 Reserved (0)

FR03 FP Dot Clock Source Register

read/write at I/O address 3D1h with index at I/O address 3D0h set to 03h

7	6	5	4	3	2	1	0
Reserved			Synthesizer	FP Clock Synth Select		Reserved (R/W)	

7-5 Reserved (000)

4 FP Clock Synthesizer Select

0: Use Video Clock Synthesizer to generate FP dot clock (default)

1: Use Memory Clock Synthesizer to generate FP dot clock.

This bit selects the graphics/video clock synthesizer to generate the FP dot clock in FP mode (FR01 bit 1 is set to 1). Note that CRT display engine always uses dot clock from the graphics/video clock synthesizer.

3-2 FP Clock Select Bits (reset state: 00)

Select graphics/video clock synthesizer frequency when not in CRT mode (FR01 bit 0 is set to 0). In CRT mode, the graphics/video clock synthesizer frequency is selected by MSR bits 3-2. See description of MSR bits 3-2.

Bits 1 0	CRT/FP Control
0 0	Select clock 0
0 1	Select clock 1
1 x	Select clock 2

1-0 Reserved (R/W) (reset state: 00)

FR04 Panel Power Sequencing Delay Register

read/write at I/O address 3D1h with index at I/O address 3D0h set to 04h

7	6	5	4	3	2	1	0
Power Up Delay				Power Down Delay			

7-4 Power Up Delay (reset state: 1000)

Programmable value of panel power sequencing during power up. This value can be programmed up to 54 milliseconds in increments of 3.4 milliseconds. A value of 0 is undefined.

3-0 Power Down Delay (reset state: 0001)

Programmable value of panel power-sequencing during power down. This value can be programmed up to 459 milliseconds in increments of 27.5 milliseconds. A value 0 is undefined.

This register controls panel power on/off sequencing delays. The generation of the clock for the panel power sequencing logic is controlled by XRCF bit 3. The delay intervals above assume a 37.5 KHz clock generated by the 14.31818 MHz reference clock. If using a 32KHz input, scale the delay intervals accordingly.

FR05 Power Down Control 1 Register

read/write at I/O address 3D1h with index at I/O address 3D0h set to 05h

7	6	5	4	3	2	1	0
CRT Mode	Reserved	Panel Off	Host Stby	Off Mode	FP Norm Refresh		

7 CRT Mode Control

- 0: Flat panel data and control signals are tri-stated with weak internal pull-down (default)
 - 1: Flat panel data and control signals are driven inactive.
- This bit is effective only in CRT mode (flat panel is not active).

6 Reserved

This bit should always be written to with a value of zero.

5 Standby and Panel Off Control

- 0: Flat panel data and control signals are driven inactive (default)
 - 1: Flat panel data and control signals are tri-stated with a weak internal pull-down.
- This bit is effective in Flat Panel Mode during Standby and Panel Off modes. This bit does not affect CRT control signals which will be driven low.

4 Host Standby Mode

- 0: Normal Mode (default)
 - 1: Standby Mode
- This bit disables the CPU interface, but allows the display to remain active. All CPU interface activity is ignored except RESET#. This bit can be cleared (re-enabling the CPU interface) by RESET# or a low-to-high transition on STNDBY#

3 Panel Off Mode

- 0: Normal mode (default)
 - 1: Panel Off mode
- When this bit is set, the chip enters Panel Off mode. In this mode, CRT/FP screen refresh is inactive but CPU interface and display memory refresh are still active. Display memory and I/O registers can still be accessed.

2-0 FP Normal Refresh Count (default = 001)

These bits specify the number of memory refresh cycles per scanline. These bits should have a minimum value of 001.

FR06 FP Power Down Control Register

read/write at I/O address 3D1h with index at I/O address 3D0h set to 06h

7	6	5	4	3	2	1	0
Reserved					SYNC Enable	Reserved (Writable)	Palette Power down

7-3 Reserved (0000-0)

2 HSync and VSync Enable When DAC is Off

0: Deactivate HSync and VSync when internal DAC is disabled (default)

1: Allow HSync and VSync to remain active when internal DAC is disabled

This bit is effective when internal DAC is disabled (XRD0=0).

1 Reserved (Writable)

This bit should always be written to with the value of 0.

0 Panel-Off VGA Palette Power down Enable

0: Disable VGA Palette power down in Panel Off mode (default)

1: Enable VGA Palette power down in Panel Off mode

FR08 FP Pin Polarity Register

read/write at I/O address 3D1h with index at I/O address 3D0h set to

7	6	5	4	3	2	1	0
Alt VSYNC Polarity	Alt HSYNC Polarity	FP Graphics Polarity	FP Text Polarity	FLM Polarity	LP Polarity	Disp Enbl Polarity	Reserved (R/W)

7 Alternate CRT VSync Polarity

This bit is used instead of MSR bit 7 when not in CRT mode FR01[0]=0.

0: Positive polarity (default)

1: Negative polarity

6 Alternate CRT HSync Polarity

This bit is used instead of MSR bit 6 when not in CRT mode FR01[0]=0.

0: Positive polarity (default)

1: Negative polarity

5 FP Graphics Video Output Polarity

This bit affects FP video data output in graphics mode only.

0: Normal polarity (default)

1: Inverted polarity

4 FP Text Video Output Polarity

This bit affects FP video data output in text mode only.

0: Normal polarity (default)

1: Inverted polarity

3 FP VSync (FLM) Polarity

0: Positive polarity (default)

1: Negative polarity

2 FP HSync (LP) Polarity

0: Positive polarity (default)

1: Negative polarity

1 FP Display Enable Polarity

0: Positive polarity (default)

1: Negative polarity

0 Reserved (R/W)

FR0A Programmable Output Drive Register

read/write at I/O address 3D1h with index at I/O address 3D0h set to 0Ah

7	6	5	4	3	2	1	0
Mem Addr Drive	HS, VS & ACTI	Reserved (Writable)	Mem Ctrl & Data	Bus Output Drive	FP Output Drive	Reserved (Writable)	

Note: This register controls the input threshold and output drive of the bus, video, and memory interface pins.

- 7 Memory Interface Address Output Drive Select**
0: Lower drive (Default)
1: Higher drive
- 6 HSYNC, VSYNC, ACTI and PCLK output drive select 0**
0: Lower drive (Default)
1: Higher drive
- 5 Reserved (Writable)**
This bit should always be set to the value of 0.
- 4 Memory Interface Control and Data Output Drive Select**
0: Lower drive (Default)
1: Higher drive
- 3 Bus Interface Output Drive Select**
0: Higher drive (Default)
1: Lower drive
- 2 Flat Panel Interface Output Drive Select**
0: Lower drive (Default)
1: Higher drive
- 1-0 Reserved (Writable)**
These bits should always be set to the value of 0.

FR0B FP Pin Control 1 Register

read/write at I/O address 3D1h with index at I/O address 3D0h set to 0Bh

7	6	5	4	3	2	1	0
Reserved		Comp Sync	Reserved	Pins W4 & U6 Select	Pins U3 & V2 Select	Pin Y4 Select	Pin V6 Select

7-6 Reserved (writable)

These bits should always be written with the value of 0.

5 Simple Composite Sync

0: Output CRT HSYNC on pin U3.

1: Output CRT HSYNC OR'd with CRT VSYNC on pin U3.

Effective only when XR0B bit 2 is set to 0.

4 Reserved (0)

3 Pin W4 and Pin U6 Select

0: Enable VEE (ENAVEE) goes to pin W4. Enable Backlight (ENABKL) goes to pin U6. (default).

1: Enable VEE (ENAVEE) goes to pin U6. Enable Backlight (ENABKL) goes to pin U6.

2 Pin U3 and Pin V2 Select

0: CRT HSync signal goes to pin U3. CRT VSync signal goes to pin V2. (default)

1: Composite Sync (CSYNC) goes to pin U3. Modified VSync signal goes to pin V2.

1 Pin Y4 Select

0: FP HSync (LP) signal goes to pin Y4 (default)

1: FP Display Enable (FP Blank#) goes to pin Y4.

0 Pin V6 Select

0: FP "M" signal goes to pin V6 (default)

1: FP Display Enable (FP Blank#) goes to pin V6.

FR0C Pin Control 2 Register

read/write at I/O address 3D1h with index at I/O address 3D0h set to 0Ch

7	6	5	4	3	2	1	0
GPIO ENABKL		Reserved (R/W)	GPIO (ACTI)		Reserved (R/W)		

7-6 GPIO1 (C32KHz) Pin Control

Bits 7 6	GPIO1 (C32KHz) Pin Control
0 0	Pin T4 is C32KHz input (default). Also see XRCF Bit 3
0 1	Reserved
1 0	Pin T4 is general purpose input 1 (GPIO1). Data is read into XR63 Bit 1
1 1	Pin T4 is general purpose output 1 (GPIO1). Data comes from XR63 Bit 1

5 Reserved (R/W) (reset state: 0)

4-3 GPIO0 (ACTI) Pin Control

Bits 4 3	GPIO0 (ACTI) Pin Control
0 0	Pin V1 is ACTI output (default)
0 1	Pin V1 is Composite Sync output
1 0	Pin V1 is general purpose input 0 (GPIO0). Data is read into XR63 Bit 0
1 1	Pin V1 is general purpose output 0 (GPIO0). Data comes from XR63 Bit 0

2-0 Reserved (R/W) (reset state: 000)

FR0F Activity Timer Control Register

read/write at I/O address 3D1h with index at I/O address 3D0h set to 0Fh

7	6	5	4	3	2	1	0
Activity Timer	Timer Action	Reserved (R/W)	Activity Timer Count				

Note: This register controls the activity timer functions. The activity timer is an internal counter that starts from a value programmed into this register (see bits 0-4 below) and is reset back to that count by read or write accesses to graphics memory or standard VGA I/O. Reading or writing extended VGA registers does not reset the counter. If no accesses occur, the counter increments until the end of its programmed interval, then activates either the ENABKL pin or Panel Off mode (as selected by bit-6 below). The timer count does not need to be reloaded once programmed and the timer enabled. Any access to the chip with the timer timed out (ENABKL active or Panel Off mode active) resets the timer and deactivates the ENABKL (or Panel Off mode) pin. The activity timer uses the same clock as the power sequencing logic. The delay intervals assume a 37.5 KHz clock. If using a 32KHz input, scale the delay intervals accordingly.

7 Enable Activity Timer

- 0: Disable activity timer (default on reset)
- 1: Enable activity timer

6 Activity Timer Action

- 0: When the activity timer count is reached, the ENABKL pin is activated (driven low to turn the backlight off)
- 1: When the activity timer count is reached, Panel Off mode is entered.

5 Reserved (R/W)

4-0 Activity Timer Count

For a 37.5KHz power sequencing clock, the counter resolution is 28.1 seconds. The minimum programmed value of 0 results in 28.1 seconds delay, and the maximum value of 1Fh results in a delay of 15 minutes.

FR10 FP Format 0 Register

read/write at I/O address 3D1h with index at I/O address 3D0h set to 10h

7	6	5	4	3	2	1	0
Reserved (R/W)	Shift Clock Divide			Mono / Color		Panel Type	

7 Reserved (R/W) (reset state: 0)

6-4 Shift Clock Divide (reset state: 000)

These bits specify the frequency ratio between the internal dot clock (DCLK) and flat panel shift clock (SHFCLK) signal.

Color TFT

Bits [6-4]	SHFCLK	Pixel / SHFCLK	Max bpp
000	DCLK	1	24
001	DCLK/2	2	12
010	—	—	—
011	—	—	—
100	—	—	—
101	—	—	—
110	—	—	—
111	—	—	—

4-bit pack Color STN-SS

Bits [6-4]	SHFCLK	Pixel / SHFCLK	Max bpp
000	DCLK	1 1/3	4
001	DCLK/2	2 2/3	8
010	DCLK/4	5 1/3	16
011	—	—	—
100	—	—	—
101	—	—	—
110	—	—	—
111	—	—	—

Monochrome STN-DD w/o frame accel.

Bits [6-4]	SHFCLK	Pixel / SHFCLK	Max bpp
000	DCLK	1	2
001	DCLK/2	2	4
010	DCLK/4	4	8
011	DCLK/8	8	16
100	—	—	—
101	—	—	—
110	—	—	—
111	—	—	—

Monochrome STN-DD w/o frame accel.

Bits [6-4]	SHFCLK	Pixel / SHFCLK	Max bpp
000	—	—	—
001	DCLK/2	2	2
010	DCLK/4	4	4
011	DCLK/8	8	8
100	DCLK/16	16	16
101	—	—	—
110	—	—	—
111	—	—	—

4-bit pack color STN-DD w/frame accel.

Bits [6-4]	SHFCLK	Pixel / SHFCLK	Max bpp
000	DCLK	2 2/3	8
001	DCLK/2	5 1/3	16
010	—	—	—
011	—	—	—
100	—	—	—
101	—	—	—
110	—	—	—
111	—	—	—

4-bit pack color STN-DD w/o frame accel.

Bits [6-4]	SHFCLK	Pixel / SHFCLK	Max bpp
000	—	—	—
001	DCLK/2	2 2/3	8
010	DCLK/4	5 1/3	16
011	—	—	—
100	—	—	—
101	—	—	—
110	—	—	—
111	—	—	—

6-4 Shift Clock Divide (continued)**3-bit pack color STN-DD w/ frame accel.**

Bits 6 5 4	SHFCLK	Pixel / SHFCLK	Max bpp
000	DCLK	2	6
001	DCLK/2	4	12
010	DCLK/4	8	24
011	—	—	—
100	—	—	—
101	—	—	—
110	—	—	—
111	—	—	—

3-bit pack color STN-DD w/o frame accel.

Bits 6 5 4]	SHFCLK	Pixel / SHFCLK	Max bpp
000	—	—	—
001	DCLK/2	2	6
010	DCLK/4	4	12
011	DCLK/8	8	24
100	—	—	—
101	—	—	—
110	—	—	—
111	—	—	—

Monochrome TFT

Bits 6 5 4	SHFCLK	Pixel/SHFCLK	Max bpp
000	DCLK	1	8
001	DCLK/2	2	8
010	DCLK/4	4	4
011	DCLK/8	8	2
100	DCLK/16	16	1
101	—	—	—
110	—	—	—
111	—	—	—

3-2 Panel Monochrome/Color Select

Bits 3 2	Panel Monochrome/Color Select
0 0	Monochrome panel: NTSC weighting color reduction algorithm (default)
0 1	Monochrome panel: Equivalent weighting color reduction algorithm
1 0	Monochrome panel: Green only color reduction algorithm
1 1	Color panel

For monochrome panels, these bits select the algorithm used to reduce 18 and 24-bit color data to 6 and 8-bit color data.

1-0 Panel Type

Bits 1 0	Panel Type
0 0	Single Panel Single Drive (SS) (default)
0 1	Reserved
1 0	Reserved
1 1	Dual Panel Dual Drive (DD)

FR11 FP Format 1 Register

read/write at I/O address 3D1h with index at I/O address 3D0h set to 11h

7	6	5	4	3	2	1	0
Res Dither	Bits Per Pixel			Dither Enable		FRC	

7 FP Restrict Dither (reset state: 0)

0: Dithering can be enabled on all modes.

1: Dithering can be enabled only on modes with more than 256 colors.

6-4 Bits Per Pixel Select (reset state: 000)

Gray/Color without dither

Bits 6 5 4	#MSBs Used	No FRC	2-Frame FRC	16-Frame FRC
000	0	—	—	—
001	1	2	—	—
010	2	4	3	—
011	3	8	5	—
100	4	16	15	16
101	5	32	31	—
110	6	64	—	—
111	8	256	—	—

Gray/Color with dither

Bits 6 5 4	#MSBs Used	No FRC	2-Frame FRC	16-Frame FRC
000	0	—	—	—
001	1	5	—	—
010	2	13	9	—
011	3	29	25	—
100	4	61	57	61
101	5	125	121	—
110	6	253	—	—
111	8	—	—	—

Notes:

No FRC is the recommended setting when interfacing with color TFT panel with more than 12 bits per pixel (4K color) or interfacing with monochrome panel with internal gray scaling. When No FRC is chosen FR11 bits 6-4 should be programmed equal to the number of bits/color of the panel. For example, a TFT panel with 18 bits/pixel color uses 6 bits/color. FR11 bits 6-4 should be programmed to 110b.

2-frame FRC should be used with color TFT panel with less than or equal to 12 bits per pixel (<4k color) or used with monochrome panel with internal gray scaling. When 2-frame FRC is chosen FR11 bits 6-4 should be programmed equal to the number of bits/color of the panel plus 1. The extra bit is for the 2-frame FRC. For example, a TFT panel with 9 bits/pixel color uses 3 bits/color. FR11 bits 6-4 should be programmed equal to 100b.

16-frame FRC should be used with STN panel. To achieve 16-frame FRC, 4 bits are needed for each color (R, G, B).

When 2-bit dither is disabled, the theoretical Color/Gray level per R, G, and B is calculated by using the formula below:

Theoretical Color/Gray level = 2^X where X is number of bits/color selected

When 2-frame FRC or 16-frame FRC is enabled the actual Color/Gray level per R, G, and B that can be achieved is less than the theoretical Color/Gray level.

When 2-bit dither is enabled, the theoretical Color/Gray level per R, G, and B is calculated by using the formula below:

Theoretical Color/Gray Level = $4 * 2^X$ where X is number of bits/color selected

3-2 Dither Enable

When 2-bit dither, 2-frame FRC, or 16-frame FRC is enabled the actual achievable Color/Gray level per R, G, and B is less than the theoretical Color/Gray level. 3-2Dither Enable

Bits 3 2	Dither Enable
0 0	Disable dithering (default)
0 1	Enable 2-bit dithering
1 0	Reserved for 4-bit dithering
1 1	Reserved

1-0 Frame Rate Control (FRC)

FRC is gray scale simulation on frame-by-frame basis to generate shades of gray or color on panels that do not generate gray/color levels internally.

Bits 1 0	Frame Rate Control (FRC)
0 0	<u>No FRC.</u> This setting may be used with all panels, especially for panels which can generate shades of grey/color internally (default).
0 1	<u>16-Frame FRC.</u> This setting may be used for panels which do not support internal gray scaling such as color STN or monochrome STN panels. This setting simulates up to 16 gray/color levels per pixel as specified in FR11 Bits 6-4.
1 0	<u>2-frame FRC.</u> This setting may be used with color/monochrome panels, especially for panels which can generate shades of gray/color internally. The valid number of bits/pixel is specified in FR11 Bits 6-4.
1 1	<u>2-frame FRC.</u> This setting may be used with color/monochrome panels, especially for panels which can generate shades of gray/color internally. The valid number of bits/pixel is specified in FR11 Bits 6-4.

FR12 FP Format 2 Register

read/write at I/O address 3D1h with index at I/O address 3D0h set to 12h

7	6	5	4	3	2	1	0
FP Data Width		Force FP Data High	Force HSYNC	FP Blank# Select	Clk Mask STN-DD	Clock Mask	Clock Divide

7-6 FP Data Width

Bits 7 6	FP Data Width
0 0	<u>16-bit panel data width</u> . For color TFT panel this is the 565 RGB interface. This is the default after reset.
0 1	<u>24-bit panel data width</u> . For color the TFT panel this is the 888 RGB interface. This setting can also be used for the 24-bit color STN-DD panel.
1 0	Reserved.
1 1	<u>36-bit panel data width</u> (TFT panels only). Program 000 in shift clock divide bits of FR10.

5 Force FP Data Signals High during Vertical Blank

- 0: Flat panel data output signals are not forced high during vertical blanking.
- 1: Flat panel data output signals are forced high during vertical blanking.

4 Force FP HSync (LP) during Vertical Blank

- 0: FP Display Enable output is generated by inverting both FP Vertical and Horizontal Blank therefore FP Display Enable will not toggle active during Vertical Blank time. FP HSync (LP) is not generated during Vertical Blank except when bit 3 is set to 1. This is the default after reset.
- 1: FP Display Enable output is generated by inverting FP Horizontal Blank only therefore FP Display Enable will be active during Vertical Blank time. FP HSync (LP) will also be active during Vertical Blank.

This bit should be set only for SS panels which require FP HSync (LP) to be active during vertical blank time when bit 3 is 0. This bit should be reset when using DD panels or when bit 3 is 1.

3 FP Display Enable (FP Blank#) Select

0: The FP Display Enable is inactive during vertical blank time because the output comes from inverting both the FP Vertical and Horizontal blank. FP HSync is not generated during vertical blank except when bit 4 is set to 1. In 480-line DD panels, this option will generate exactly 240 FP HSync (LP) pulses. This is the default after reset.

1: The FP Display Enable is active during Vertical blank time since the output comes from inverting the FP Horizontal Blank enable. FP HSync will also be active during vertical blank.

This bit controls FP Display Enable (FP Blank#) generation. This bit also affects FP HSync (LP) generation.

2 Shift Clock Mask for STN-DD

0: Allow Shift Clock output to toggle in first line of Vertical Blank. This is the default after reset.

1: Force Shift Clock output low in first line of Vertical Blank.

This is an option to eliminate dark lines in the middle of STN-DD panels.

1 Shift Clock Mask

0: Allow Shift Clock output to toggle outside the display enable interval. This is the default after reset.

1: Force Shift Clock output low outside the display enable interval.

0 Shift Clock Divide

0: Shift Clock to Dot Clock relationship is specified by FR10[6:4]. This is the default after reset.

1: Shift Clock is further divided by 2 and different video data is valid on the rising and falling edges of Shift Clock.

FR13 FP Format 3 Register

read/write at I/O address 3D1h with index at I/O address 3D0h set to 13h

7	6	5	4	3	2	1	0
Reserved (R/W)					Set Up Time	Pixel Packing	

7-3 Reserved (R/W) (reset state: 0000-0)

2 Increase Setup Time 16-bit Color STN-DD

0: Normal data setup time with respect to SHFCLK falling edge (default). Maximum SHFCLK frequency is DCLK/2 (1:1 duty cycle).

1: Extended data setup time with respect to SHFCLK falling edge. The setup time is increased by approximately half of a dot clock cycle. This is done by extending SHFCLK high time by half of a dot clock cycle. Maximum SHFCLK frequency is DCLK/2.5 with a 1.5:1 duty cycle.

This bit is effective only for 16-bit Color STN-DD when frame acceleration is enabled or for 8-bit Color STN-DD when frame acceleration is disabled.

1-0 Color STN Pixel Packing

Bits 1 0	Color STN Pixel Packing
0 0	3-bit pack (default).
0 1	4-bit pack.
1 0	Reserved.
1 1	Extended 4-bit pack. Bits FR10 Bits 6-4 must be programmed to 001. This setting may only be used for 8-bit interface color STN SS panels.

This determines the type of pixel packing (the RGB pixel output sequence) for color STN panels. These bits must be programmed to 00 for monochrome STN panels and for all TFT panels.

FR16 FRC Option Select Register

read/write at I/O address 3D1h with index at I/O address 3D0h set to 16h

7	6	5	4	3	2	1	0
Reserved (R/W)					FRC Opt 3	FRC Opt 2	FRC Opt 1

7-3 Reserved (R/W)

These bits should always be written with 0's for future compatibility.

2 FRC Option 3

This affects 2-frame FRC and normally should be set to 1.

0: FRC data changes every frame

1: FRC data changes every other frame

1 FRC Option 2

This affects 16-frame FRC and normally should be set to 1.

0: 2x2 FRC sub-matrix

1: 2x4 FRC sub-matrix

0 FRC Option 1

This affects 16-frame FRC and normally should be set to 1.

0: 5x31 FRC matrix

1: 16x32 FRC matrix

FR17 Polynomial FRC Control Register

read/write at I/O address 3D1h with index at I/O address 3D0h set to 17h

7	6	5	4	3	2	1	0
Polynomial M Value				Polynomial N Value			

This register sets the FRC polynomial counters, which are row and column offsets for each panel type and are usually determined by trial and error. These values affect the quality of both 2-frame and the 16-frame FRC algorithms and require readjustment when the horizontal or vertical parameters change, especially when the vertical total parameter is changed.

7-4 Polynomial 'M' Value

3-0 Polynomial 'N' Value

FR18 FP Text Mode Control Register

read/write at I/O address 3D1h with index at I/O address 3D0h set to 18h

7	6	5	4	3	2	1	0
Reserved						Text Enhancement	

7-2 Reserved (0)

1-0 Text Enhancement

Bits 1 0	Text Enhancement
0 0	Normal text (default)
0 1	Text attribute 07h and 0Fh are reversed to maximize the brightness of the normal DOS prompt. This affects both CRT and Flat Panel displays.
1 0	Text attribute 07h and 0Fh are reversed to maximize the brightness of the normal DOS prompt. This affects Flat Panel displays.
1 1	Reserved

FR19 Blink Rate Control Register

read/write at I/O address 3D1h with index at I/O address 3D0h set to 19h

7	6	5	4	3	2	1	0
Char Blink Duty Cycle				Cursor Blink Rate			

7-6 Character Blink Duty Cycle

These bits specify the character blink (also called 'attribute blink') duty cycle in text mode.

Bits 7 6	Character Blink Duty Cycle
0 0	50%
0 1	25%
1 0	50% (default on reset)
1 1	75%

For setting 00, the character blink period is equal to the cursor blink period. For all other settings, the character blink period is twice the cursor blink period (character blink is half as fast as cursor blink).

5-0 Cursor Blink Rate (default = 03h)

These bits specify the cursor blink period in terms of number of VSyncs (50% duty cycle). In text mode, the character blink period and duty cycle is controlled by bits 7-6 of this register. These bits should be programmed to:

$$\text{Programmed value} = ((\text{Actual Value}) / 2) - 1$$

Note: In graphics mode, the pixel blink period is fixed at 32 VSyncs per cursor blink period with 50% duty cycle (16 on and 16 off).

FR1A STN-DD Buffering Control Register

read/write at I/O address 3D1h with index at I/O address 3D0h set to 1Ah

7	6	5	4	3	2	1	0
Reserved (Writable) (0000:00)						Frame Accel Enable (0)	Buffering Enable (0)

7-2 Reserved (Writable)

These bits should always be set to the value of 0.

1 STN-DD Frame Acceleration Enable

Enabling STN-DD frame acceleration doubles the screen refresh rate on an attached STN-DD panel relative to an attached CRT (each CRT frame corresponds to two STN-DD panel frames). The required memory bandwidth does not increase. In the simultaneous display mode, if the CRT refresh rate is 60Hz, the STN-DD panel refresh rate is 120Hz when STN-DD frame acceleration is enabled. Under the same conditions, the STN-DD panel refresh rate is 60Hz when STN-DD frame acceleration is disabled. Usually, STN-DD panels display higher quality images when STN-DD frame acceleration is enabled. If STN-DD frame acceleration is disabled, then the STN-DD buffer must be large enough to hold an entire frame consisting of 3-bits per pixel organized as 10 pixels per 32-bit Dword. With STN-DD frame acceleration enabled, the required STN-DD buffer size is half this amount (only half a frame need be stored).

0 STN-DD Buffering Enable

0: Disables STN-DD buffering. This is the default after reset.

1: Enables STN-DD buffering.

STN-DD buffering is required for STN-DD panel operation. For STN-SS panel operation, STN-DD buffering is not required so this bit must be set to 0.

FR1E M (ACDCLK) Control Register

read/write at I/O address 3D1h with index at I/O address 3D0h set to 1Eh

7	6	5	4	3	2	1	0
ACDCLK Control	M(ACDCLK) Count (ACDCNT)						

7 M (ACDCLK) Control

0: The M (ACDCLK) phase changes depending on bits 0-6 of this register

1: The M (ACDCLK) phase changes every frame if the frame accelerator is not used. If the frame accelerator is used, the M (ACDCLK) phase changes every other frame.

This register is used only in flat panel mode.

6-0 M (ACDCLK) Count (ACDCNT)

These bits define the number of HSyncs between adjacent phase changes on the M (ACDCLK) output. These bits are effective only when bit 7 = 0 and the contents of this register are greater than 2.

Programmed Value = Actual Value - 2

FR1F Diagnostic Register

read/write at I/O address 3D1h with index at I/O address 3D0h set to 1Fh

7	6	5	4	3	2	1	0
Reserved (R/W)		Pixel Data Output Mode		Misc Mod Control 2	Misc Mod Control 2	Bypass VGA Palette	Diagnostic Mode

7-6 Reserved (R/W) (reset state: 00)

5-4 Pixel Data Pin Diagnostic Output Mode

These bits control the output of pins: SHFCLK, LP, M, P bits 15-0 and CA bits 7-0.

00: Normal Operation (default)

01: Output the following internal signals:

Signal	Pins
PDCLK	FLM
RDDE	LP
RDBLANK	M
RDVIDEO bits 23-16	CA bits 7-0
RDVIDEO bits 15-0	P bits 15-0

10: Output the following internal signals on P bits 15-0

PDDELETE, PDGDCK, PHHSTR[2:0], PHREMAIN bits 10-0

11: Output the following internal signals on P bits 13-0

SS1ROMBOE, FHC32KHZI, FHXMEMRQ, T2DDSPBP, T2DDSPEN, T2DHBLANK, MXSQRDBG bits 7-0

3 FP Miscellaneous module control 2

0: Normal Operation. This is the default after reset.

1: Enable the ring oscillator. The waveform is output on ACTI pin. In addition, it is also output on pin A25 if the configuration option of pin AA4 is chosen to output clocks on A24 and A25.

2 FP Miscellaneous module control 2

0: Normal Operation. This is the default after reset.

1: Bypass clock divider for testing purposes

1 Bypass VGA Palette

0: Normal Operation. This is the default after reset.

1: Bypass internal VGA palette

0 FP Interface Diagnostic Mode

0: Normal Operation. This is the default after reset.

1: FP Interface Diagnostic Mode

FR20 FP Horizontal Panel Display Size LSB Register

read/write at I/O address 3D1h with index at I/O address 3D0h set to 20h

7	6	5	4	3	2	1	0
FP Horizontal Panel Size LSB							

7-0 FP Horizontal Panel Size LSB

This parameter signifies the end of FP Horizontal Display Enable and the start of FP Horizontal Blank time relative to the start of FP Horizontal Display Enable. The most significant bits are programmed in FR25 bits 3-0. In FP mode (FR01 bit 1 is set to 1), this parameter is counted using a counter which is clocked with FP dot clock divided by 8 in all modes and is independent of horizontal compensation.

$$\text{Programmed Value} = \text{Actual Value} - 1$$

FR21 FP Horizontal Sync Start LSB Register

read/write at I/O address 3D1h with index at I/O address 3D0h set to 21h

7	6	5	4	3	2	1	0
FP Horizontal Sync Start LSB							

7-0 FP Horizontal Sync Start LSB

In FP mode, this parameter is counted using a counter which is clocked with the FP dot clock divided by 8 in all modes and is independent of horizontal compensation. This parameter signifies the start of CRT HSync when not in CRT mode (FR01[0]=0). The most significant bits are programmed in FR25 bits 7-4.

$$\text{Programmed Value} = \text{Actual Value} - 1$$

FR22 FP Horizontal Sync End Register

read/write at I/O address 3D1h with index at I/O address 3D0h set to 22h

7	6	5	4	3	2	1	0
Reserved (R/W)				FP Horizontal Sync End			

7-5 Reserved (R/W) (Reset state: xxx)

4-0 FP Horizontal Sync End

In FP mode, this parameter is counted using a counter which is clocked with the FP dot clock divided by 8 in all modes and is independent of horizontal compensation. This parameter signifies the end of CRT HSync when not in CRT mode (FR01 bit 0 is set to 0). Only the 5 least significant bits are programmed.

FR23 FP Horizontal Total LSB Register

read/write at I/O address 3D1h with index at I/O address 3D0h set to 23h

7	6	5	4	3	2	1	0
FP Horizontal Total Bits 7-0							

7-0 FP Horizontal Total Bits 7-0

In FP mode, this parameter is counted using a counter which is clocked with the FP dot clock divided by 8 in all modes and is independent of horizontal compensation. This parameter signifies the end of FP Horizontal Blank time and the start of FP Horizontal Display Enable relative to the start of the previous FP Horizontal Display Enable, i.e., the total size from one Horizontal Enable to the next. The most significant bits are programmed in FR26 bits 3-0.

Programmed Value = Actual Value – 5

FR24 FP HSync (LP) Delay LSB Register

read/write at I/O address 3D1h with index at I/O address 3D0h set to 24h

7	6	5	4	3	2	1	0
FP HSYNC (LP) Delay Bits 7-0							

7-0 FP HSync (LP) Delay Bits 7-0

In FP mode, this parameter is counted using a counter which is clocked with the FP dot clock divided by 8 in all modes and is independent of horizontal compensation. This register is effective when FR27 bit 7 is set to 0 and signifies the start of FP HSync (LP) measured from start of FP Horizontal Display Enable. This allows FP HSync (LP) to be positioned independently from CRT HSync. The most significant bits are programmed in FR26 bits 7-4.

FR25 FP Horizontal Overflow 1 Register

read/write at I/O address 3D1h with index at I/O address 3D0h set to 25h

7	6	5	4	3	2	1	0
Reserved for Sync Start MSB				Reserved for Panel Size MSB			

7-4 Reserved (0) for FP Horizontal Sync Start MSB

See description of FR20.

3-0 Reserved (0) for FP Horizontal Panel Size MSB

See description of FR21.

FR26 FP Horizontal Overflow 2 Register

read/write at I/O address 3D1h with index at I/O address 3D0h set to 26h

7	6	5	4	3	2	1	0
FP HSYNC (LP) Delay Bits 11-8				FP Horizontal Total Bits 11-8			

7-4 FP HSync (LP) Delay Bits 11-8

See description of FR23.

3-0 FP Horizontal Total Bits 11-8

See description of FR24.

FR27 FP HSync (LP) Width and Disable Register

read/write at I/O address 3D1h with index at I/O address 3D0h set to 27h

7	6	5	4	3	2	1	0
Delay Disable	FP HSync LP Width						

7 FP HSync (LP) Delay Disable

0: FP HSync (LP) delay enable

1: FP HSync (LP) delay disable

In FP mode, this parameter is counted using a counter which is clocked with the FP dot clock divided by 8 in all modes and is independent of horizontal compensation.

6-0 FP HSync (LP) Width

Programmed Value = Actual Value - 1

FR30 FP Vertical Panel Size LSB Register

read/write at I/O address 3D1h with index at I/O address 3D0h set to 30h

7	6	5	4	3	2	1	0
FP Vertical Panel Size LSB							

In FP mode (FR01 bit 1 is set to 1), this register is used to establish the end of FP Vertical Display Enable and the start of FP Vertical Blank time. The most significant bits are programmed in FR35 bits 3-0.

7-0 FP Vertical Panel Size LSB

Programmed Value = Actual Value - 1

FR31 FP Vertical Sync Start LSB (FR31) Register

read/write at I/O address 3D1h with index at I/O address 3D0h set to 31h

7	6	5	4	3	2	1	0
FP Vertical Sync Start LSB							

7-0 FP Vertical Sync Start LSB

In FP mode (FR01 bit 1 is set to 1), this register signifies the start of CRT VSync (FR01 bit 0 is set to 0). The most significant bits are programmed in FR35 bits 7-4.

Programmed Value = Actual Value - 1

FR32 FP Vertical Sync End Register

read/write at I/O address 3D1h with index at I/O address 3D0h set to 32h

7	6	5	4	3	2	1	0
Reserved				FP Vertical Sync End			

7-4 Reserved (R/W) (Reset state: xxxx)

In FP mode (FR01 bit 1 is set to 1), this register signifies the end of CRT VSync. Only the 4 least significant bits are programmed.

3-0 FP Vertical Sync End

Programmed Value = Actual Value – 1

FR33 FP Vertical Total Register

read/write at I/O address 3D1h with index at I/O address 3D0h set to 33h

7	6	5	4	3	2	1	0
Vertical Total Bits 7-0							

7-0 Vertical Total Bits 7-0

In FP mode (FR01 bit 1 is set to 1), this register is used to establish the end of FP Vertical Blank time and the start of FP Vertical Display Enable. The most significant bits are programmed in FR36 bits 3-0.

FP Programmed Value = Actual Value – 2

FR34 FP VSync (FLM) Delay Register

read/write at I/O address 3D1h with index at I/O address 3D0h set to 34h

7	6	5	4	3	2	1	0
FP VSync (FLM) Delay Bits 7-0							

7-0 FP VSync (FLM) Delay Bits 7-0

In FP mode (FR01 bit 1 is set to 1), this register is effective when FR37 bit 7 is set to 0 and FR37 bit 6 is set to 0. This register signifies the start of FP VSync (FLM) measured from start of CRT VSync which is programmed in FR31. This allows FP VSync (FLM) to be located in a different position from CRT VSync. The most significant bits are programmed in FR36 bits 7-4.

Programmed Value = Actual Value – 1

FR35 FP Vertical Overflow 1 Register

read/write at I/O address 3D1h with index at I/O address 3D0h set to 35h

7	6	5	4	3	2	1	0
Vertical Sync Start [11-8]				Vertical Panel Size [11-8]			

7-4 FP Vertical Sync Start (bits 11-8)

See description of FR30.

3-0 FP Vertical Panel Size (bits 11-8)

See description of FR31.

FR36 FP Vertical Overflow 2 Register

read/write at I/O address 3D1h with index at I/O address 3D0h set to 36h

7	6	5	4	3	2	1	0
FP FLM Delay Bits 11-8				FP Vertical Total Bits 11-8			

7-4 FP FLM Delay Bits 11-8
See description of FR34.

3-0 FP Vertical Total (bits 11-8)
See description of FR33.

FR37 FP VSync (FLM) Disable Register

read/write at I/O address 3D1h with index at I/O address 3D0h set to 37h

7	6	5	4	3	2	1	0
FLM Delay	FLM Select	FP VSync (FLM) width			Reserved (000)		

When the FP Display engine is enabled (FR01 bit one is set to 1) it uses this register.

- 7 FP VSync (FLM) Delay Disable**
This bit is effective when FR37 bit 6 is set to 0
0: FP VSync (FLM) delay enable
1: FP VSync (FLM) delay disable
- 6 FP VSync (FLM) select**
0: FP VSync (FLM) is generated using FR37[7] and FP VSync (FLM) Delay (FR36[6:4] and FR34).
1: FP VSync (FLM) is the same as CRT VSync. FR37 bit 7 is ignored in this case.
- 5-3 FP Vsync (FLM) width.**
These bits are effective only if bit 6 is 0.

Programmed value = actual value -1

- 2-0 Reserved**
These bits should always be written to with a value of zero.

FR40 Horizontal Compensation Register

read/write at I/O address 3D1h with index at I/O address 3D0h set to 40h

7	6	5	4	3	2	1	0
Reserved		EGHC	THCP		ETHC	EHC	EHCP

This register is used in FP mode (FR01 Bit 1 set to 1)

7-6 Reserved (R/W) (reset state: 00)

5 FP Enable Graphics Horizontal Compensation (EGHC) (reset state: 0)

0: Disable graphics mode horizontal compensation.

1: Enable graphics mode horizontal compensation which consists of horizontal stretching and FR41 is used to specify stretching for different horizontal resolutions.

This bit is effective only when bit 0 is 1.

4-3 Text Horizontal Compensation Priority (THCP)

Bits 4 3	Text Horizontal Compensation Priority (THCP)
0 0	<u>Allow 9-dot compression to 8-dot if needed.</u> If horizontal panel size is wide enough, 8-dot text remains 8-dot text and 9-dot text remains 9-dot text. If horizontal panel size is not wide enough, then 8-dot text remains 8-dot text and 9-dot text is forced to 8-dot text. This is the default after reset.
0 1	<u>No compression or expansion.</u> 8-dot text remains 8-dot text and 9-dot text remains as 9-dot text regardless of horizontal panel size.
1 0	<u>Allow 8-dot expansion to 9-dot, or 9-dot compression to 8-dot, depending on horizontal panel size.</u> If horizontal panel size is wide enough, 8-dot text is forced to 9-dot text and 9-dot text remains 9-dot text. If horizontal panel size is not wide enough then 8-dot text remains 8-dot text and 9-dot text is forced to 8-dot text.
1 1	<u>Allow 8-dot and 9-dot expansion to 10-dot, or 8-dot expansion to 9-dot, or 9-dot compression to 8-dot, depending on horizontal panel size.</u> If horizontal panel size is wide enough, 8-dot text is forced to 10-dot text and 9-dot text is forced to 10-dot text. Otherwise, if horizontal panel size is wide enough, 8-dot text is forced to 9-dot text and 9-dot text remains 9-dot text. If horizontal panel size is not wide enough, then 8-dot text remains 8-dot text and 9-dot text is forced to 8-dot text.

These bits are effective only when bit 0 is 1 and bit 2 is 1. These bits determine the text mode compression/stretching method to be applied if horizontal panel size is wide enough. If after applying the specified text compression/stretching, the horizontal panel size is still wider than the stretched image then further stretching will be applied using the same algorithm used for horizontal graphics compensation.

2 Enable Text Horizontal Compensation (ETHC)

- 0: Disable text mode horizontal compensation. This is the default after reset.
- 1: Enable text mode horizontal compensation.

This bit is effective only when bit 0 is 1. Text mode horizontal compensation priority/method is specified in bits [4:3]

1 Enable Horizontal Centering (EHC)

- 0: Disable horizontal centering. This is the default after reset.
- 1: Enable horizontal centering. Horizontal left and right borders will be computed automatically.

0 Enable Horizontal Compensation (EHCP)

- 0: Disable horizontal compensation. This is the default after reset.
- 1: Enable horizontal compensation.

FR41 Horizontal Stretching Register

read/write at I/O address 3D1h with index at I/O address 3D0h set to 41h

7	6	5	4	3	2	1	0
Reserved (0000)				Reserved (R/W)	Hor Stretch 1024 Col	Hor Stretch 800 Col	Hor Stretch 640 Col

This register is used when FR01 bit 1 is set to 1 and FR40 bit 0 is set to 1 and graphics mode is enabled. This register must be set before FR40.

7-4 Reserved (0)

1

3 Reserved (R/W) (reset state: 0)

2 FP Enable Horizontal Stretching for 1024-column Graphics Mode

0: Disable horizontal stretching for 1024-column graphics mode.

1: Enable horizontal stretching for 1024-column graphics mode.

Note: That 1024-column graphics mode includes 512-column graphics mode with horizontal pixel doubling enabled.

1 FP Enable Horizontal Stretching for 800-column Graphics Mode

0: Disable horizontal stretching for 800-column graphics mode.

1: Enable horizontal stretching for 800-column graphics mode.

Note: That 800-column graphics mode includes 400-column graphics mode with horizontal pixel doubling enabled.

0 FP Enable Horizontal Stretching for 640-column Graphics Mode

0: Disable horizontal stretching for 640-column graphics mode.

1: Enable horizontal stretching for 640-column graphics mode.

Note: The 640-column graphics mode includes 320-column graphics mode with horizontal pixel doubling enabled.

FR48 Vertical Compensation Register

read/write at I/O address 3D1h with index at I/O address 3D0h set to 48h

7	6	5	4	3	2	1	0
Reserved (R/W) (000)			ETVS	Text Mode Stretch	EVLRL	Vertical Centering	EVCP

7-5 Reserved (R/W) (reset state: 0)

When the FP Display engine is enabled (FR01[1]=1), it uses this register.

4 Enable Text Mode Vertical Stretching (ETVS)

- 0: Disable vertical stretching (default)
- 1: Enable vertical stretching

3 Text Mode Vertical Stretching Priority

- 0: Priority: ETVS, EVLR (default)
 - 1: Priority: EVLR, ETVS
- This bit is effective in text modes if bits 2 and 4 are set.

2 Enable Vertical Line Replication (EVLRL)

- 0: Disable vertical line replication (default)
 - 1: Enable vertical line replication
- This bit is effective in text and graphics modes.

1 Enable Vertical Centering

- 0: Disable vertical centering (default)
 - 1: Enable vertical centering
- This bit is effective only when bit 0 is "1".

0 Enable Vertical Compensation (EVCP)

- 0: Disable vertical compensation feature (default)
- 1: Enable vertical compensation feature

FR49-4C Text Mode Vertical Stretching Register

read/write at I/O address 3D1h with index at I/O address 3D0h set to 49h-4Ch

7	6	5	4	3	2	1	0
Replication Specification							

7-0 Replication Specifications

Bits 7 0	Replication Specifications
0 0	No replication
0 1	Replicate once
1 0	Replicate twice
1 1	Replicate three times

Font lines beyond 16 are not replicated.

This register specifies the new text mode vertical stretching (along with FR4A, FR4B, FR4C). FR49(MSB), FR4A(LSB) and FR4B (MSB), FR4C(LSB) constitute two 16 bit registers. Each of the 16 pairs of bits specify scan line replication as shown above.

FR49: Text Mode Vertical Stretching 0 MSB

FR4A: Text Mode Vertical Stretching 0 LSB

FR4B: Text Mode Vertical Stretching 1 MSB

FR4C: Text Mode Vertical Stretching 1 LSB

FR4D Vertical Line Replication Register

read/write at I/O address 3D1h with index at I/O address 3D0h set to 4Dh

7	6	5	4	3	2	1	0
VLRHH				VLRHL			

This register is used in FP mode (FR01 bit 1 set to 1) and when vertical line replication is enabled. The 4 bit number specifies the number of lines between replicated lines. Double scanned lines are counted. The state machine starts stretching by using the lower nibble value. If the stretched display does not fit it uses the next higher value. The process continues until the count is equal to upper nibble value or the display fits. The lower nibble value must be less than or equal to upper nibble value. Set this register before FR40.

7-4 FP Vertical Line Replication Height High (VLRHH)

3-0 FP Vertical Line Replication Height Low (VLRHL)

FR4E Selective Vertical Stretching Disable Register

read/write at I/O address 3D1h with index at I/O address 3D0h set to 4Eh

7	6	5	4	3	2	1	0
Reserved (00)		Disable 600 Graph	Disable 480 Graph	Disable 400 Graph	Disable 350 Graph	Disable 400 Text	Disable 350 Text

This register is used to selectively disable vertical stretching based on the vertical display end parameter. The register is qualified by master enable bits in FR48. Set this register before setting FR40.

7-6 Reserved (R/W) (reset state: xx)

5 Disable 600-line Graphics Stretching

- 0: Disable stretching
- 1: Enable stretching

4 Disable 480-line Graphics Stretching

- 0: Disable stretching
- 1: Enable stretching

3 Disable 400-line Graphics Stretching

- 0: Disable stretching
- 1: Enable stretching

2 Disable 350-line Graphics Stretching

- 0: Disable stretching
- 1: Enable stretching

1 Disable 400-line Text Stretching

- 0: Disable stretching
- 1: Enable stretching

0 Disable 350-line Text Stretching

- 0: Disable stretching
- 1: Enable stretching

FR70 TMED Red Seed Register

read/write at I/O address 3D1h with index at I/O address 3D0h set to 70h

7	6	5	4	3	2	1	0
TMED Red Seed							

7-0 TMED Red Seed

The 8-bit value written to this register specifies the seed value used in the TMED algorithm for red pixel data to improve images on dual-scan passive matrix LCD panels.

FR71 TMED Green Seed Register

read/write at I/O address 3D1h with index at I/O address 3D0h set to 71h

7	6	5	4	3	2	1	0
TMED Green Seed							

7-0 TMED Green Seed

The 8-bit value written to this register specifies the seed value used in the TMED algorithm for green pixel data to improve images on dual-scan passive matrix LCD panels.

FR72 TMED Blue Seed Register

read/write at I/O address 3D1h with index at I/O address 3D0h set to 72h

7	6	5	4	3	2	1	0
TMED Blue Seed							

7-0 TMED Blue Seed

The 8-bit value written to this register specifies the seed value used in the TMED algorithm for blue pixel data to improve images on dual-scan passive matrix LCD panels.

FR73 TMED Control Register

read/write at I/O address 3D1h with index at I/O address 3D0h set to 73h

7	6	5	4	3	2	1	0
TMED Enable	Scheme Select	Shades per Color Select		Horizontal Beat Suppression			

Note: The recommended default value to which this register should be set is F5h.

7 TMED Enable

- 0: Disables TMED.
- 1: Enables TMED.

6 TMED Scheme Select

- 0: Selects TMED energy distribution scheme 2.
- 1: Selects TMED energy distribution scheme 1.

5-4 TMED Shades per Color Select

- 00: Selects 33 shades for red, 65 shades for green, and 33 shades for blue.
- 01: Selects 65 shades for red, green, and blue.
- 10: Selects 129 shades for red, green, and blue.
- 11: Selects 256 shades for red, green, and blue.

3-0 TMED Horizontal Beat Suppression

The value written to these 4 bits specifies the horizontal beat suppression factor.

FR74 TMED2 Control Register

read/write at I/O address 3D1h with index at I/O address 3D0h set to 74h

7	6	5	4	3	2	1	0
Vertical Beat Suppression				Method 1 Enable	Method 2 Enable	Method 1 Scheme Sel	Method 2 Scheme Sel

Note: The recommended default value to which this register should be set is 5Fh.

7-4 Vertical Beat Suppression

The value written to these 4 bits specifies the vertical beat suppression factor.

3 TMED2 Method 1 Enable

0: Disables TMED2 method 1.

1: Enables TMED2 method 1.

2 TMED2 Method 2 Enable

0: Disables TMED2 method 2.

1: Enables TMED2 method 2.

1 TMED2 Method 1 Scheme Select

0: Selects scheme 1.

1: Selects scheme 2.

0 TMED2 Method 2 Scheme Select

0: Selects scheme 1.

1: Selects scheme 2.

Chapter 16

Multimedia Registers

Table 16-1: Multimedia Registers

Name	Register Function	Access Via 3D3h	Index at 3D2h Set to Value
MR00	Module Capability Register	read-only	00h
MR01	Secondary Capability Register	read-only	01h
MR02	Capture Control 1 Register	read/write	02h
MR03	Capture Control 2 Register	read/write	03h
MR04	Capture Control 3 Register	read/write	04h
MR05	Capture Control 4 Register	read/write	05h
MR06-08	Capture Memory Address PTR1 Registers	read/write	06h - 08h
MR09-0B	Capture Memory Address PTR2 Registers	read/write	09h - 0Bh
MR0C	Capture Memory Width (Span) Register	read/write	0Ch
MR0E	Capture Window X-LEFT Low Register	read/write	0Eh
MR0F	Capture Window X-LEFT High Register	read/write	0Fh
MR10	Capture Window X-RIGHT Low Register	read/write	10h
MR11	Capture Window X-RIGHT High Register	read/write	11h
MR12	Capture Window Y-TOP Low Register	read/write	12h
MR13	Capture Window Y-TOP High Register	read/write	13h
MR14	Capture Window Y-BOTTOM Low Register	read/write	14h
MR15	Capture Window Y-BOTTOM High Register	read/write	15h
MR16	H-SCALE Register	read/write	16h
MR17	V-SCALE Register	read/write	17h
MR18	Capture Frame Count Register	read/write	18h
MR1E	Playback Control 1 Register	read/write	1Eh
MR1F	Playback Control 2 Register	read/write	1Fh
MR20	Playback Control 3 Register	read/write	20h
MR21	Double Buffer Status Register	read/write	21h
MR22-24	Playback Memory Address PTR1 Registers	read/write	22h - 24h
MR25-27	Playback Memory Address PTR2 Registers	read/write	25h - 27h
MR28	Playback Memory Line Fetch Width Register	read/write	28h
MR2A	Playback Window X-LEFT Low Register	read/write	2Ah
MR2B	Playback Window X-LEFT High Register	read/write	2Bh
MR2C	Playback Window X-RIGHT Low Register	read/write	2Ch
MR2D	Playback Window X-RIGHT High Register	read/write	2Dh
MR2E	Playback Window Y-TOP Low Register	read/write	2Eh
MR2F	Playback Window Y-TOP High Register	read/write	2Fh
MR30	Playback Window Y-BOTTOM Low Register	read/write	30h
MR31	Playback Window Y-BOTTOM High Register	read/write	31h
MR32	H-ZOOM Register	read/write	32h
MR33	V-ZOOM Register	read/write	33h
MR34	Memory Line Out Total Register	read/write	34h
MR3C	Color Key Control 1 Register	read/write	3Ch
MR3D-3F	Color Keys Registers	read/write	3Dh - 3Fh
MR40-42	Color Key Masks Registers	read/write	40h - 42h
MR43	Line Count Low Register	read-only	43h
MR44	Line Count High Register	read-only	44h

MR00 Module Capability Register

read-only at I/O address 3D3h with index at address 3D2h set to 00h

7	6	5	4	3	2	1	0
Reserved						Capture	Playback

7-2 Reserved

1 Capture Available

0: Absent

1: Included

0 Playback Available

0: Absent

1: Included

MR01 Secondary Capability Register

read-only at I/O address 3D3h with index at address 3D2h set to 01h

7	6	5	4	3	2	1	0
Reserved							

7-0 Reserved

MR02 Capture Control 1 Register

read/write at I/O address 3D3h with index at address 3D2h set to 02h

default = 00h

7	6	5	4	3	2	1	0
Field Det Method	Field Det Polarity	VSYNC Polarity	HSYNC Polarity	RGB Mode	Color	Reserved	Interlace

- 7 Field Detect Method**
 0: Trailing Edge of V
 1: Leading Edge of V
- 6 Field Detect Polarity**
 0: Normal
 1: Inverted
- 5 VSYNC Polarity**
 0: Low asserted
 1: High asserted
- 4 HSYNC Polarity**
 0: Low asserted
 1: High asserted
- 3 RGB Mode**
 0: RGB16
 1: RGB15
- 2 Color**
 0: YUV
 1: RGB
- 1 Reserved**
- 0 Interlace**
 0: Interlace Enabled
 1: Non-Interlace

MR03 Capture Control 2 Register

read/write at I/O address 3D3h with index at address 3D2h set to 03h

default = 00h

7	6	5	4	3	2	1	0
V Scaling Method		Y-Scale	X-Scale	Field Select	Frame/Field Capture	Continuous/Single	Capture Enable

7-6 V Scaling Method

- 00: Normal
- 01: Reserved
- 10: Overwrite
- 11: Reserved

5 Y-Scale Enable

- 0: Disabled
- 1: Scaled on V

4 X-Scale Enable

- 0: Disabled
- 1: Scaled on H

3 Field Select

- 0: Field 0
 - 1: Field 1
- Bit-3 is only effective when Bit-2 = 1

2 Frame/Field Capture

- 0: Frame
- 1: Field

1 Continuous/Single Frame/Field Video Data Capture

- 0: Causes the continuous capturing of video data from the video data port.
- 1: Causes the capture of a single frame or field (depending on the setting of bit 2 of this register) from the video data port.

0 Capture Enable

- 0: Stop
- 1: Start

MR04 Capture Control 3 Register

read/write at I/O address 3D3h with index at address 3D2h set to 04h

default = 00h

7	6	5	4	3	2	1	0
Cap Frm/Fld Drop Enable	Shift Fields Down	Dbl Buffer Ptr Select	Dbl Buffer Enable	Dbl Buffer Mode Select	Horiz Filter Enable	Y-Capture Direction	X-Capture Direction

7 Capture Frame/Field Drop Enable

0: Causes the capture of video data from the video data port without dropping frames or fields.

1: Causes the dropping of the number of frames/fields specified in the Capture Frame/Field Drop Count Register (MR18) between every frame/field that is saved.

6 Shift Fields Down

0: Keeps the video playback window at its normal location -- i.e., it is not shifted vertically.

1: Shifts the odd fields in the video playback window down by one scanline.

5 Double Buffer Pointer Select

0: PTR1 in use

1: PTR2 in use

4 Double Buffer Enable

0: Double buffering disabled

1: Double buffering enabled

3 Double Buffer Mode Select

0: CPU Forced

1: V Locked

2 Horizontal Filter Enable

0: No Filter

1: Filter pixels with horizontal filter

1 Y-Capture Direction

0: Normal: top to bottom

1: Flipped: bottom to top

0 X-Capture Direction

0: Normal: left to right

1: Mirrored: right to left

Note: Changing the X- or Y- capture direction (Bits 1-0) will also require a change in the acquisition memory address pointer.

MR05 Capture Control 4 Register

read/write at I/O address 3D3h with index at address 3D2h set to 05h

default = 00h

7	6	5	4	3	2	1	0
Input Byte Swap	UV SWAP	Pixel Qual Polarity	Pixel Qual Enable	Input VSYNC	Last Frame Captured	Current Address	Actual Capture

7 Input Byte Swap

- 0: Y on low 8 input pins, UV on high 8 input pins
- 1: Y on high 8 input pins, UV on low 8 input pins (VESA style)

6 UV SWAP

- 0: Normal UV sequence
- 1: Exchange U and V

5 Pixel Qualifier Polarity

- 0: Non-inverted
- 1: Inverted

4 Pixel Qualifier Enable

- 0: Continuous pixels gated by blank
- 1: PIXEN qualifies valid pixels

3 Input VSYNC (read only)

(After polarity correction)

2 Last Frame Captured (read only)

- 0: PTR1
 - 1: PTR2
- (Effective only with double buffering)

1 Current Address Pointer (read only)

- 0: PTR1 (Acquisition memory pointer 1)
 - 1: PTR2 (Acquisition memory pointer 2)
- Indicates which buffer is being captured if double buffering is enabled.

0 Actual Capture (read only)

- 0: Hardware frame capture stopped
- 1: Hardware frame capture active (synchronized to V)

MR06 Capture Memory Address PTR1 Low Register

read/write at I/O address 3D3h with index at address 3D2h set to 06h

7	6	5	4	3	2	1	0
Capture Memory Address PTR1 Low Bits 7-3					Reserved (00)		

7-3 Capture Memory Address PTR1 Low Bits 7-3

2-0 Reserved

MR07 Capture Memory Address PTR1 Mid Register

read/write at I/O address 3D3h with index at address 3D2h set to 07h

7	6	5	4	3	2	1	0
Capture Memory Address PTR1 Mid Bits 15-8							

7-0 Capture Memory Address PTR1 Mid Bits 15-8

MR08 Capture Memory Address PTR1 High Register

read/write at I/O address 3D3h with index at address 3D2h set to 08h

7	6	5	4	3	2	1	0
Reserved (00)		Capture Memory Address PTR1 High Bits 21-16					

7-6 Reserved

5-0 Capture Memory Address PTR1 High Bits 21-16

MR09 Capture Memory Address PTR2 Low Register

read/write at I/O address 3D3h with index at address 3D2h set to 09h

7	6	5	4	3	2	1	0
Capture Memory Address PTR2 Low Bits 7-3					Reserved (00)		

7-3 Capture Memory Address PTR2 Low Bits 7-3

2-0 Reserved

MR0A Capture Memory Address PTR2 Mid Register

read/write at I/O address 3D3h with index at address 3D2h set to 0Ah

7	6	5	4	3	2	1	0
Capture Memory Address PTR2 Mid Bits 15-8							

7-0 Capture Memory Address PTR2 Mid Bits 15-8

MR0B Capture Memory Address PTR2 High Register

read/write at I/O address 3D3h with index at address 3D2h set to 0Bh

7	6	5	4	3	2	1	0
Reserved (00)		Capture Memory Address PTR2 High Bits 21-16					

7-6 Reserved

5-0 Capture Memory Address PTR2 High Bits 21-16

MR0C Capture Line Memory Storage Width Register

read/write at I/O address 3D3h with index at address 3D2h set to 0Ch

7	6	5	4	3	2	1	0
Memory Width (span) Bits 7-0							

7-0 Memory Width (Span) Bits 7-0

This value is calculated as follows:

$$((\text{width of line in pixels}) / (\text{number of pixels per quadwords})) - 1.$$

MR0E Capture Window X-LEFT Low Register

read/write at I/O address 3D3h with index at address 3D2h set to 0Eh

7	6	5	4	3	2	1	0
Capture Window X-LEFT Bits 7-0							

7-0 Acquisition Window X-LEFT Bits 7-0

MR0F Capture Window X-LEFT High Register

read/write at I/O address 3D3h with index at address 3D2h set to 0Fh

7	6	5	4	3	2	1	0
Reserved					Capture Window X-LEFT Bits 10-8		

7-3 Reserved

2-0 Capture Window X-LEFT Bits 10-8

MR10 Capture Window X-RIGHT Low Register

read/write at I/O address 3D3h with index at address 3D2h set to 10h

7	6	5	4	3	2	1	0
Capture Window X-RIGHT Low Bits 7-0							

7-0 Capture Window X-RIGHT Low Bits 7-0

MR11 Capture Window X-RIGHT High Register

read/write at I/O address 3D3h with index at address 3D2h set to 11h

7	6	5	4	3	2	1	0
Reserved					Capture Window X-RIGHT High Bits 7-0		

7-3 Reserved

2-0 Capture Window X-RIGHT High [10:08]

MR12 Capture Window Y-TOP Low Register

read/write at I/O address 3D3h with index at address 3D2h set to 12h

7	6	5	4	3	2	1	0
Capture Window YTOP Bits 7-0							

7-0 Capture Window Y-TOP Bits 7-0

MR13 Capture Window Y-TOP High Register

read/write at I/O address 3D3h with index at address 3D2h set to 13h

7	6	5	4	3	2	1	0
Reserved					Capture Window YTOP Bits 10-8		

7-3 Reserved

2-0 Capture Window Y-TOP Bits 10-8

MR14 Capture Window Y-BOTTOM Low Register

read/write at I/O address 3D3h with index at address 3D2h set to 14h

7	6	5	4	3	2	1	0
Capture Window Y-BOTTOM Bits 7-0							

7-0 Capture Window Y-BOTTOM Bits 7-0

MR15 Capture Window Y-BOTTOM High Register

read/write at I/O address 3D3h with index at address 3D2h set to

7	6	5	4	3	2	1	0
Reserved					Capture. Window Y-BOTTOM Bits 10-8		

7-3 Reserved

2-0 Capture Window Y-BOTTOM Bits 10-8

MR16 H-SCALE Register

read/write at I/O address 3D3h with index at address 3D2h set to 16h

7	6	5	4	3	2	1	0
H-SCALE Bits 7-0							

7-0 H-SCALE Bits 7-0

MR17 V-SCALE Register

read/write at I/O address 3D3h with index at address 3D2h set to 17h

7	6	5	4	3	2	1	0
V-SCALE Bits 7-0							

7-0 V-SCALE Bits 7-0

MR18 Capture Frame/Field Count Register

read/write at I/O address 3D3h with index at I/O address 3Dh2 set to 18h

7	6	5	4	3	2	1	0
AQ Capture Frame/Field Count Bits 7-0							

7-0 Capture Frame/Field Drop Count

When the dropping of frames/fields is enabled by setting bit 2 of the Capture Control 2 Register (MR03) to 1, these 8 bits set the number of captured frames/fields to be dropped between every frame/field that is captured and saved.

MR1E Playback Control 1 Register

read/write at I/O address 3D3h with index at address 3D2h set to 1Eh

default = 00h

7	6	5	4	3	2	1	0
Reserved			Playback Interlace	V-ZOOM Enable	H-ZOOM Enable	Y-Playback Direction	X-Playback Direction

7-5 Reserved

4 Playback Interlace Enable

- 0: Non-Interlaced
- 1: Interlaced

3 V-ZOOM Enable

- 0: Normal
- 1: Video playback is zoomed to the degree specified in the V-ZOOM Register (MR33).

2 H-ZOOM Enable

- 0: Normal
- 1: Video playback is zoomed to the degree specified in the H-ZOOM Register (MR32).

1 Y-Playback Direction

- 0: Normal: top to bottom
- 1: Flipped: bottom to top

Be sure to change memory pointer value of PTR1 (MR22 - MR24) and/or PTR2 (MR25 - MR27) if flipped.

0 X-Playback Direction

- 0: Normal: left to right
- 1: Mirrored: right to left

Be sure to change memory pointer value of PTR1 (MR22 - MR24) and/or PTR2 (MR25 - MR27) if mirrored.

MR1F Playback Control 2 Register

read/write at I/O address 3D3h with index at address 3D2h set to 1Fh

default = 00h

7	6	5	4	3	2	1	0
V Inter Enable	V Inter Mode	H Inter Enable	Reserved	Color Mode Select	Reserved	UV Sign	Color Type Select

7 V Interpolate Enable

0: Disable

1: Enable

6 V Interpolate Mode

0: De-block

1: Running Average (when bit 7 is set)

5 H Interpolate Enable

4 Reserved

3 Color Mode Select

0: YUV

1: RGB

See color mode table below.

2 Reserved

1 UV Sign

0: UV Unsigned (signed offset)

1: UV Signed (2's complement)

0 Color Type Select (See bit 3)

0: Normal (U and V, or RGB16)

1: Exchange U and V positions, or RGB15

Color Mode table for bit-3:

Bit 3 2 1 0	Color Format
0 x 0 0	YUV 4:2:2
0 x 0 1	YVU 4:2:2; UV Swap
0 x 1 0	YUV 4:2:2; UV=2's comp
0 x 1 1	YVU 4:2:2; UV=2'comp, UV swap
1 x x 0	RGB16; R5G6B5 (B=LSB)
1 x x 1	RGB15, xR5G5B5 (B=LSB)

MR20 Playback Control 3 Register

read/write at I/O address 3D3h with index at address 3D2h set to 20h

default = 00h

7	6	5	4	3	2	1	0
Playback Vert. Auto-center Enable	Playback Width Source	Playback Pointer Select			Double Buffer Trigger	Reserved	

7 Playback Vertical Auto-Centering Enable

0: Allow software to employ a delay to properly center the playback window vertically. This is done usually via bit 4 of the Pixel Pipeline Configuration Register 1 (XR81).

1: Activate a hardware-based auto-centering mechanism.

6 Playback Width Source

0: Use MR28 for Playback width

1: Use MR34 for Playback width

5 Playback Pointer Select 1

0: The pointer to the location in the frame buffer from which frames/fields of video data are played back is selected by bit 4 of this register.

1: The pointer to the location in the frame buffer from which frames/fields of video data are played back is controlled by bit 3 of this register.

4 CPU Double Buffer Flag

0: Playback memory address PTR1

1: Playback memory address PTR2

3 Playback Pointer Select 2

0: The pointer to the location in the frame buffer from which frames/fields of video data are played back is selected by bit 4 of this register.

1: The pointer to the location in the frame buffer from which frames/fields of video data are played back toggles between the addresses indicated by PTR1 and PTR2 after each frame/field captured.

Bit			Playback Pointer Select
5	4	3	
0	0	X	Selects playback memory pointer address 1
0	1	X	Selects playback memory pointer address 2
1	0	0	Selects playback memory pointer address 1
1	0	1	Pointer to the location from which frames/fields of data are read toggles between addresses indicated by PTR1 and PTR2 after each frame/field captured
1	1	0	Selects playback memory pointer address 2
1	1	1	Pointer to the location from which frames/fields of data are read toggles between addresses indicated by PTR1 and PTR2 after each frame/field captured

2 Double Buffer Trigger

0: Retain old PTR

1: Take new PTR on next VSYNC if bit 5=1

1-0 Reserved

MR21 Double Buffer Status Register

read/write at I/O address 3D3h with index at address 3D2h set to 21h

7	6	5	4	3	2	1	0
Reserved						Buffer Pointer	Buffer Trigger

7-2 Reserved

1 Double Buffer Pointer in Use

- 0: PTR1
- 1: PTR2

0 Double Buffer Trigger Status

- 0: Taken
- 1: Pending

MR22 Playback Memory Address PTR1 Low Register

read/write at I/O address 3D3h with index at address 3D2h set to 22h

7	6	5	4	3	2	1	0
Playback Memory Address PTR1 Low Bits 7-3					Reserved (00)		

7-3 Playback Memory Address PTR1 Low Bits 7-3

2-0 Reserved

MR23 Playback Memory Address PTR1 Mid Register

read/write at I/O address 3D3h with index at address 3D2h set to 23h

7	6	5	4	3	2	1	0
Playback Memory Address PTR1 Mid Bits 15-8							

7-0 Playback Memory Address PTR1 Mid Bis 15-8

MR24 Playback Memory Address PTR1 High Register

read/write at I/O address 3D3h with index at address 3D2h set to 24h

7	6	5	4	3	2	1	0
Reserved (00)		Playback Memory Address PTR1 High Bits 21-16					

7-6 Reserved

5-0 Playback Memory Address PTR1 HighBits 21-16

MR25 Playback Memory Address PTR2 Low Register

read/write at I/O address 3D3h with index at address 3D2h set to 25h

7	6	5	4	3	2	1	0
Playback Memory Address PTR2 Low Bits 7-3					Reserved (000)		

7-3 Playback Memory Address PTR2 Low Bits 7-3

2-0 Reserved

MR26 Playback Memory Address PTR2 Mid Register

read/write at I/O address 3D3h with index at address 3D2h set to 26h

7	6	5	4	3	2	1	0
Playback Memory Address PTR2 Mid Bits 15-8							

7-0 Playback Memory Address PTR2 Mid Bits 15-8

MR27 Playback Memory Address PTR2 High Register

read/write at I/O address 3D3h with index at address 3D2h set to 27h

7	6	5	4	3	2	1	0
Reserved (00)		Playback Memory Address PTR2 High Bits 21-16					

7-6 Reserved

5-0 Playback Memory Address PTR2 High Bits 21-16

MR28 Playback Line Memory Fetch Width Register

read/write at I/O address 3D3h with index at address 3D2h set to 28h

7	6	5	4	3	2	1	0
Playback Line Memory Fetch Width Bits 7-0							

7-0 Playback Line Memory Fetch Width Bits 7-0

These 8 bits specify the number of quadwords read by the playback engine from the frame buffer to display a horizontal line's worth of video data. Normally, this value is set equal to the actual number of quadwords required to store a horizontal line's worth of video data captured from the video data port -- i.e., normally this value is the same as that of register MROC.

If bit 6 of the Playback Control 3 Register (MROC) is set to 0, then this register also specifies the number of quadwords out of a horizontal line's worth of video data that is actually played back, starting at the left-most edge of the video playback window.

This value is calculated as follows:

$$((\text{width of line in pixels}) / (\text{number of pixels per quadwords})) - 1.$$

MR2A Playback Window X-LEFT Low Register

read/write at I/O address 3D3h with index at address 3D2h set to 2Ah

default = 00h

7	6	5	4	3	2	1	0
Playback Window X-LEFT Low Bits 7-0							

7-0 Playback Window X-LEFT Low Bits 7-0

MR2B Playback Window X-LEFT High Register

read/write at I/O address 3D3h with index at address 3D2h set to 2Bh

default = 00h

7	6	5	4	3	2	1	0
Reserved					Playback Window X-LEFT High Bits 10-8		

7-3 Reserved

2-0 Playback Window X-LEFT High Bits 10-8

MR2C Playback Window X-RIGHT Low Register

read/write at I/O address 3D3h with index at address 3D2h set to 2Ch

default = 00h

7	6	5	4	3	2	1	0
Playback Window X-RIGHT Low Bits 7-0							

7-0 Playback Window X-RIGHT Low Bits 7-0

MR2D Playback Window X-RIGHT High Register

read/write at I/O address 3D3h with index at address 3D2h set to 2Dh

default = 00h

7	6	5	4	3	2	1	0
Reserved					Playback Window X-RIGHT High Bits 10-8		

7-3 Reserved

2-0 Playback Window X-RIGHT High Bits 10-8

MR2E Playback Window Y-TOP Low Register

read/write at I/O address 3D3h with index at address 3D2h set to 2Eh

default = 00h

7	6	5	4	3	2	1	0
Playback Window Y-TOP Low Bits 7-0							

7-0 Playback Window Y-TOP Low Bits 7-0

MR2F Playback Window Y-TOP High Register

read/write at I/O address 3D3h with index at address 3D2h set to 2Fh

default = 00h

7	6	5	4	3	2	1	0
Reserved					Playback Window Y-TOP High Bits 10-8		

7-3 Reserved

2-0 Playback Window Y-TOP High Bits 10-8

MR30 Playback Window Y-BOTTOM Low Register

read/write at I/O address 3D3h with index at address 3D2h set to 30h

default = 00h

7	6	5	4	3	2	1	0
Playback Window Y-BOTTOM Low Bits 7-0							

7-0 Playback Window Y-BOTTOM Low Bits 7-0

MR31 Playback Window Y-BOTTOM High Register

read/write at I/O address 3D3h with index at address 3D2h set to 31h

default = 00h

7	6	5	4	3	2	1	0
Reserved					Playback Window Y-BOTTOM High Bits 10-8		

7-3 Reserved

2-0 Playback Window Y-BOTTOM High Bits 10-8

MR32 H-ZOOM Register

read/write at I/O address 3D3h with index at address 3D2h set to 32h

default = 00h

7	6	5	4	3	2	1	0
H-ZOOM						Reserved (00)	

7-2 H-ZOOM

When enabled by setting bit 2 of the Playback Control 1 Register (MR1E) to 1, these six bits are used to specify the zoom factor by which the playback image is magnified.

Zoom factor = $100h / (\text{value of bits 7 to 2 of this register})$

Examples of programmed values:

Bits 7 6 5 4 3 2	Resulting Zoom Factor
1 0 0 0 0 0	Magnify by 2
0 1 0 0 0 0	Magnify by 4
0 0 1 0 0 0	Magnify by 8

1-0 Reserved

These bits always return the value of 0 when read.

MR33 V-ZOOM Register

read/write at I/O address 3D3h with index at address 3D2h set to 33h

default = 00h

7	6	5	4	3	2	1	0
V-ZOOM						Reserved (00)	

7-2 V-ZOOM

When enabled by setting bit 3 of the Playback Control 1 Register (MR1E) to 1, these six bits are used to specify the zoom factor by which the playback image is magnified.

Zoom factor = $100h / (\text{value of bits 7 to 2 of this register})$

Examples of programmed values:

Bits 7 6 5 4 3 2	Resulting Zoom Factor
1 0 0 0 0 0	Magnify by 2
0 1 0 0 0 0	Magnify by 4
0 0 1 0 0 0	Magnify by 8

1-0 Reserved

These bits always return the value of 0 when read.

MR34 Playback Line Display Width Register

read/write at I/O address 3D3h with index at address 3D2h set to 34h

default = 00h

7	6	5	4	3	2	1	0
Playback Line Display Width Bits 7-0							

7-0 Playback Line Display Width Bits 7-0

If bit 6 of the Playback Control 3 Register (MR0C) is set to 1, then this register specifies the number of quadwords out of a horizontal line's worth of video data that is actually played back, starting at the left-most edge of the video playback window.

This value is calculated as follows: ((width of line in pixels) / (number of pixels per quadwords)) - 1.

MR3C Color Key Control 1 Register

read/write at I/O address 3D3h with index at address 3D2h set to 3Ch

default = 00h

7	6	5	4	3	2	1	0
LSB Disable	16-Bit Overlay	Blank Display	Reserved		XY Rectangle	Color Key	Video Overlay

7 LSB (Bit 0) disable

0: Normal "Blue bit 0"

1: Red, green, and blue bit 0 is forced to 0 at MMUX output (for masking display of key when using 16/24 bit overlay key).

6 16-bit Overlay Key

0: Normal color key

1: Color key "Green_7" is routed to "Blue_0"

5 Blank Display

0: Graphics and video playback NOT blanked

1: Graphics and video playback blanked

4-3 Reserved

2 XY Rectangle Enable

0: XY Rectangular Region off

1: XY Rectangular Region enabled

1 Color Key Enable

0: Color Key off

1: Color Key enabled

0 Video Overlay Enable

0: Graphics only, if no video playback

1: Video Playback Window enabled

MR3D-3F Color Key Registers

read/write at I/O address 3D3h with index at address 3D2h set to 3Dh -3Fh

MR3D: Red, MR3E: Green, MR3F: Blue

7	6	5	4	3	2	1	0
Color Keys							

7-0 Red/Green/Blue Color Keys

0: Use the corresponding color key

1: Do not use color key

MR40-42 Color Key Mask Registers

read/write at I/O address 3D3h with index at address 3D2h set to 40h - 42h

MR40: Red Mask, MR41: Green Mask, MR42: Blue Mask

7	6	5	4	3	2	1	0
Color Key Masks							

7-0 Red/Green/Blue Color Key Masks

0: Use the corresponding color key

1: Do not use color key

The table below describes the bits and values for the color key registers in different graphics modes.

Table 16-2: Color Key Bit Assignments:

Display Mode	R_Key	G_Key	B_Key	Masks		
				R_Key	G_Key	B_Key
4-Bit Indexed			Blue Bits 3-0	FF	FF	F0
8-Bit Indexed			Blue Bits 7-0	FF	FF	00
15-Bit RGB		Green Bits 6-0	Blue Bits 7-0	FF	80	00
16-Bit RGB		Green Bits 7-0	Blue Bits 7-0	FF	00	00
24-Bit RGB	Red Bits 7-0	Green Bits 7-0	Blue Bits 7-0	00	00	00
16-Bit Key		Green Bit 7		FF	7F	FF
24-Bit Key			Blue Bits 7-0	FF	FF	FE

Note: Color Key bit assignments:

In 15 Bit RGB (5:5:5) Mode:

RED Bits 7-3 = G_Key Bits 6-2

GREEN Bits 7-3= G_Key Bits 1-0, B_Key Bits 7-5

BLUE Bis 7-3 = B_Key Bits 4-0

In 16 Bit RGB (5:6:5) Mode:

RED Bits 7-3 = G_Key Bits 7-3

GREEN Bits 7-2= G_Key Bits 2-0, B_Key Bits 7-5

BLUE Bits 7-3 = B_Key Bits 4-0

MR43 Line Count Low Register

read-only at I/O address 3D3h with index at address 3D2h set to 43h

7	6	5	4	3	2	1	0
Line Counter for Graphics Display Bits 7-0							

7-0 Line Counter for Graphics Display Low Bits 7-0

MR44 Line Count High Register

read-only at I/O address 3D3h with index at address 3D2h set to 44h

7	6	5	4	3	2	1	0
Reserved				Line Counter for Graphics Display Bits 11-8			

7-4 Reserved

3-0 Line Counter for Graphics Display High Bits 11-08

This register enables the read back of the display vertical "line counter".

Chapter 17

BitBLT Registers

These registers exist in the upper memory space of the host bus. The BitBLT registers exist at an offset of 4MB from the base address of the upper memory space.

Name	Function	Access	Offset
BR00	Source and Destination Span Register	read/write	0x400000
BR01	Pattern/Source Expansion Background Color & Transparency Key Register	read/write	0x400004
BR02	Pattern/Source Expansion Foreground Color Register	read/write	0x400008
BR03	Monochrome Source Control Register	read/write	0x40000C
BR04	BitBLT Control Register	read/write	0x400010
BR05	Pattern Address Register	read/write	0x400014
BR06	Source Address Register	read/write	0x400018
BR07	Destination Address Register	read/write	0x40001C
BR08	Destination Width & Height Register	read/write	0x400020
BR09	Source Expansion Background Color & Transparency Key Register	read/write	0x400024
BR0A	Source Expansion Foreground Color Register	read/write	0x400028

BR00 Source and Destination Span Register

read/write at memory space offset 0x400000h

word or doubleword accessible

31	30	29	28	27	26	25	24	23	22	21	20	19	18	17	16
Reserved (000)			Destination Span (x:xxx:xxx:xxx)												
15	14	13	12	11	10	9	8	7	6	5	4	3	2	1	0
Reserved (000)			Source Span (x:xxx:xxx:xxx)												

31-29 Reserved

These bits always return 0 when read.

28-16 Destination Span

These 13 bits specify the span from the first byte in a scanline's worth of destination data to the first byte in the next scanline's worth. In other words, these bits specify the amount by which the destination address specified in BR07 should be incremented after a scanline's worth of destination data has been written to the destination in order to point to where the first byte in the next scanline's worth of destination data should be written.

If the destination data is to be contiguous (i.e., it will be a single unbroken block of data where the last byte of a scanline's worth of data is immediately followed by the first byte of the next scanline's worth), then the value of this span should be set equal to the number of bytes in each scanline's worth of destination data.

15-13 Reserved

These bits always return 0 when read.

12-0 Source Span

These 13 bits are used only when color source data is being used as an input in a BitBLT operation. If the source data is monochrome, or no source data is to be used, then the BitBLT engine will ignore the value carried by these bits.

When color source data is read from the frame buffer, these 13 bits specify the span from the first byte in a scanline's worth of color source data to the first byte in the next scanline's worth. In other words, these bits specify the amount by which the source address specified in BR06 should be incremented after a scanline's worth of color source data has been read from the frame buffer in order to point to where the first byte in the next scanline's worth of color source data should be read.

When the host CPU provides the color source data through the BitBLT data port, these 13 bits specify the number of bytes to be counted from the first byte in one scanline's worth of color source data to the first byte in the next scanline's worth.

If the color source data is contiguous (i.e., it is a single unbroken block of data where the last byte of a scanline's worth of data is immediately followed by the first byte of the next scanline's worth), then the value of this span should be set equal to the number of bytes in each scanline's worth of color source data.

BR01 Pattern/Source Expansion Background Color & Transparency Key Register

read/write at memory space offset 0x400004h
word or doubleword accessible

31	30	29	28	27	26	25	24	23	22	21	20	19	18	17	16
Reserved (0000:0000)								Pat/Src Expansion Background Color & Transparency Key Bits 23-16 (xxxx:xxxx)							
15	14	13	12	11	10	9	8	7	6	5	4	3	2	1	0
Pattern/Source Expansion Background Color & Transparency Bits 15-0 (xxxx:xxxx:xxxx:xxxx)															

31-24 Reserved

These bits always return 0 when read.

23-0 Pattern/Source Expansion Background Color & Transparency Key Bits 23-0

These 24 bits are used to specify the background color for the color expansion of either monochrome pattern data only, or both monochrome pattern data and monochrome source data (depending on the setting of bit 27 of BR03). When bit 27 of BR03 is set so that this register is used in the color expansion of monochrome pattern data only, BR09 is used to specify the background color for the color expansion of monochrome source data.

These 24 bits are also optionally used to specify the key color for whichever form of color transparency is selected via bits 16-15 of BR04 (depending on the setting of bit 27 of BR03).

Whether bits 7-0, 15-0 or 23-0 of this register are used in both the color expansion and color transparency processes depends upon the color depth to which the BitBLT engine has been set.

BR02 Pattern/Source Expansion Foreground Color Register

read/write at memory space offset 0x400008h

word or doubleword accessible

31	30	29	28	27	26	25	24	23	22	21	20	19	18	17	16
Reserved (0000:0000)								Pat/Src Expansion Foreground Color Bits 23-16 (xxxx:xxxx)							
15	14	13	12	11	10	9	8	7	6	5	4	3	2	1	0
Pattern/Source Expansion Foreground Color Bits 15-0 (xxxx:xxxx:xxxx:xxxx)															

31-24 Reserved

These bits always return 0 when read.

23-0 Pattern/Source Expansion Foreground Color Bits 23-0

These 24 bits are used to specify the foreground color for the color expansion of either monochrome pattern data only, or both monochrome pattern data and monochrome source data (depending on the setting of bit 27 of BR03). When bit 27 of BR03 is set so that this register is used in the color expansion of monochrome pattern data only, BR0A is used to specify the foreground color for the color expansion of monochrome source data.

Whether bits 7-0, 15-0 or 23-0 of this register are used in the color expansion process depends upon the color depth to which the BitBLT engine has been set.

BR03 Monochrome Source Control Register

read/write at memory space offset 0x40000Ch

word or doubleword accessible

31	30	29	28	27	26	25	24	23	22	21	20	19	18	17	16
Reserved (0000)				Src Exp (x)	Mono Src Align (xxx)			Reserved (00)		Monochrome Source Data Initial Discard (xx:xxxx)					
15	14	13	12	11	10	9	8	7	6	5	4	3	2	1	0
Reserved (00)		Monochrome Source Data Right Clipping (xx:xxxx)						Reserved (00)		Monochrome Source Data Left Clipping (xx:xxxx)					

31-28 Reserved

These bits always return 0 when read.

27 Monochrome Source Expansion Color Register Select

0: This causes the background and foreground colors for the color expansion of monochrome source data to be specified by BR01 and BR02, respectively.

1: This causes the background and foreground colors for the color expansion of monochrome source data to be specified by BR09 and BR0A, respectively.

26-24 Monochrome Source Scanline Data Alignment

Note: These bits are used only when the source data is monochrome.

These 3 bits are used to configure the BitBLT engine for the byte alignment of each scanline's worth of monochrome source data during a BitBLT operation, as each scanline's worth of monochrome source data is received.

Refer to the section describing the BitBLT engine for further details concerning the requirements for how monochrome source data must be organized.

Bit 26 25 24	Specified Monochrome Source Data Alignment
0 0 0	Reserved
0 0 1	Bit-Aligned
0 1 0	Byte-Aligned
0 1 1	Word-Aligned
1 0 0	Doubleword-Aligned
1 0 1	Quadword-Aligned
1 1 0	Reserved
1 1 1	Reserved

23-22 Reserved

These bits always return 0 when read.

21-16 Monochrome Source Data Initial Discard

Note: These bits are used only when the source data is monochrome.

These 6 bits are used to specify how many bits (up to 63 bits) of monochrome source data should be skipped over in the first quadword of source data in order to reach the first bit of valid or desired monochrome source data. These bits are normally used to clip one or more of the first scanline's worth of monochrome source data, (i.e. clipping monochrome source data from the top).

15-14 Reserved

These bits always return 0 when read.

13-8 Monochrome Source Data Right Clipping

Note: These bits are used only when the source data is monochrome.

These 6 bits are used to specify how many bits (up to 63 bits) of monochrome source data should be discarded from the end of each scanline's worth of valid or desired monochrome source data. These bits are normally used to clip monochrome source data from the right.

7-6 Reserved

These bits always return 0 when read.

5-0 Source Data Left Clipping

Note: These bits are used only when the source data is monochrome.

These 6 bits are used to indicate how many bits (up to 63 bits) of monochrome source data should be discarded from the beginning of each scanline's worth of valid or desired monochrome source data. These bits are normally used to clip the monochrome source data from the left.

BR04 BitBLT Control Register

read/write at memory space offset 0x400010h

word or doubleword accessible

31	30	29	28	27	26	25	24	23	22	21	20	19	18	17	16
BB Stat (0)	Reserved (000:00)					BitBLT Eng Color Depth (00)	Dep Ctrl (0)	Pattern Vertical Alignment (000)			Sol Pat (0)	Pat Dep (0)	Pat Mask (0)	Tran Sel (0)	

15	14	13	12	11	10	9	8	7	6	5	4	3	2	1	0
Tran Sel (0)	Tran Enl (0)	Src Mask (0)	Src Dep (0)	Rsvd (0)	Src Sel (0)	Starting Point Select (00)		Bit-Wise Operation Select (00h)							

31 BitBLT Engine Status

Note: This bit is read-only -- writes to this bit are ignored.

0: Indicates that the BitBLT engine is idle.

1: Indicates that the BitBLT engine is busy.

30-26 Reserved

These bits always return 0 when read.

25-24 BitBLT Engine Color Depth

When bit 23 of this register is set to 1, these 2 bits configure the color depth of the BitBLT engine. If bit 23 of this register is set to 0, then this function is performed by bits 5 and 4 of XR20.

Bit 25 24	BitBLT Engine Color Depth Selected
0 0	8 bits per pixel (1 byte per pixel) This is the default after reset.
0 1	16 bits per pixel (2 bytes per pixel)
1 0	24 bits per pixel (3 bytes per pixel)
1 1	Reserved

The choice of color depth configures the BitBLT engine to work with one, two or three bytes per pixel. This directly affects the number of bytes of graphics data that the BitBLT engine will read and write for a given number of pixels. In the case of monochrome source or pattern data, this setting directly affects the color depth into which such monochrome data will be converted during the color expansion process.

It is strongly recommended that, when possible, the color depth of the BitBLT engine be set to match the color depth to which the rest of graphics system has been set. However, if the rest of the graphics system has been set to a color depth that is not supported by the BitBLT engine, then it is strongly recommended that the BitBLT engine not be used. See the section on the BitBLT engine for more information.

23 BitBLT Engine Color Depth Control Select

0: Bits 5 and 4 of the BitBLT Configuration Register (XR20) are used to configure the BitBLT engine for one of three color depths. This is the default after reset.

1: Bits 25 and 24 of this register are used to configure the BitBLT engine for one of three color depths.

22-20 Pattern Vertical Alignment

Specifies which scanline's worth (i.e., which 1 of the 8 horizontal rows) of the 8x8 pattern data will appear in the first scanline's worth of the destination output data. Depending on the location of the destination, the upper left corner of the upper left tile of the pattern data is usually aligned with the upper left corner of the destination output data as the pattern data is tiled into the destination. The BitBLT engine determines the horizontal alignment of the leftmost tiles of pattern data relative to the destination using the lower order bits of the destination address specified in BR07. However, the vertical alignment relative to the destination must be specified using these 3 bits.

19 Solid Pattern Select

Note: This bit applies only when the pattern data is monochrome (determined by bit 18 of this register).

0: Causes monochrome pattern data to actually be read and used as is normal, if indeed monochrome pattern data is being used as an input to a BitBLT operation.

1: Causes the BitBLT engine to forgo the process of reading the pattern data. Instead, the presumption is made that all of the bits of the pattern data are set to 0. The pattern operand for all bit-wise operations is forced to the background color specified in BR01.

18 Pattern Color Depth

0: Specifies that the pattern data is in color, and therefore, can have a color depth of 8, 16, or 24 bits per pixel.

1: Specifies that the pattern data is monochrome, and therefore, has a color depth of 1 bit per pixel.

17 Monochrome Pattern Write-Masking

Note: This bit applies only when the pattern data is monochrome (determined by bit 18 of this register).

This bit enables a form of per-pixel write-masking in which monochrome pattern data is used a pixel mask that controls which pixels at the destination will be written to by the BitBLT engine.

0: This disables the use of monochrome pattern data as a write mask, allowing normal operation of the BitBLT engine with regard to the use of monochrome pattern data.

1: Wherever a bit in monochrome pattern data carries the value of 0, the byte(s) of the corresponding pixel at the destination are NOT written, thereby preserving any data already carried by those bytes.

16-15 Color Transparency Select

These 2 bits are used to select the type of color transparency to be performed.

When color transparency is enabled by setting bit 14 of this register to 1, the color value carried within bits 23-0 of either BR01 or BR09 is used as a key color to mask the writing of pixel data to the destination on a per-pixel basis. Before each pixel at the destination is written, a comparison is made between this key color and another color, and whether or not that given pixel at the destination will actually be written depends upon the result of that comparison.

Whether BR01 or BR09 is used to supply the key color depends on the setting of bit 27 of BR03 since the same register that is used to supply the key color for color transparency also happens to be used to supply the background color for monochrome-to-color expansion. Also, depending on the type of color transparency selected, the other color value to which the key color is compared may be the color value resulting from the bit-wise operation selected via bits 7-0 of this register.

Bit 16 15	Form of Per-Pixel Color Comparison Selected
0 0	The color value carried by bits 23-0 of either BR01 or BR09 is compared to the color value resulting from the bit-wise operation being performed for the current pixel. If these two color values are NOT the same, then the byte(s) for the current pixel at the destination will be written with the color value resulting from the bit-wise operation.
0 1	The color value carried by bits 23-0 of either BR01 or BR09 is compared to the color value already specified in the byte(s) for the current pixel at the destination. If these two color values are NOT the same, then the byte(s) for the current pixel at the destination will be written with the color value resulting from the bit-wise operation.
1 0	The color value carried by bits 23-0 of either BR01 or BR09 is compared to the color value resulting from the bit-wise operation being performed for the current pixel. If these two color values ARE the same, then the byte(s) for the current pixel at the destination will be written with the color value resulting from the bit-wise operation.
1 1	The color value carried by bits 23-0 of either BR01 or BR09 is compared to the color value already specified in the byte(s) for the current pixel at the destination. If these two color values ARE the same, then the byte(s) for the current pixel at the destination will be written with the color value resulting from the bit-wise operation.

Note: Color transparency can be used only when the BitBLT engine is set to a color depth of 8 or 16 bits per pixel, but not 24 bits per pixel. If the BitBLT engine has been set to a color depth of 24 bits per pixel, then bit 14 of this register should always remain set to 0 to disable color transparency.

14 Color Transparency Enable

These bit is used to enable or disable color transparency.

When color transparency is enabled, the color value carried within bits 23-0 of either BR01 or BR09 is used as a key color to mask the writing of pixel data to the destination on a per-pixel basis. Before each pixel at the destination is written, a comparison is made between this key color and another color, and whether or not that given pixel at the destination will actually be written depends upon the result of that comparison.

Whether BR01 or BR09 is used to supply the key color depends on the setting of bit 27 of BR03 since the same register that is used to supply the key color for color transparency also happens to be used to supply the background color for monochrome-to-color expansion. Also, depending on the type of color transparency selected via bits 16-15 of this register, the other color value to which the key color is compared may be the color value resulting from the bit-wise operation selected via bits 7-0 of this register.

0: Disables color transparency.

1: Enables color transparency.

Note: Color transparency can be used only when the BitBLT engine is set to a color depth of 8 or 16 bits per pixel, but not 24 bits per pixel. If the BitBLT engine has been set to a color depth of 24 bits per pixel, then this bit should always remain set to 0 to disable color transparency.

13 Monochrome Source Write-Masking

Note: This bit applies only when the source data is monochrome (determined by bit 12 of this register).

This bit enables a form of per-pixel write-masking in which monochrome source data is used as a pixel mask that controls which pixels at the destination will be written to by the BitBLT engine.

0: This disables the use of monochrome source data as a write mask, allowing normal operation of the BitBLT engine with regard to the use of monochrome source data.

1: Wherever a bit in monochrome source data carries the value of 0, the byte(s) of the corresponding pixel at the destination are NOT written, thereby preserving any data already carried by those bytes.

12 Source Color Depth

0: Specifies that the source data is in color, and therefore, can have a color depth of 8, 16, or 24 bits per pixel.

1: Specifies that the source data is monochrome, and therefore, has a color depth of 1 bit per pixel. This setting should be used only if bit 8 of this register is set to 0.

Note: This bit must be set to 0 whenever a bit-wise operation is selected (using bits 7-0 of this register) that does not use source data.

11 Reserved (Writable)

This bit should always be written with the value of 0.

10 Source Select

0: Configures the BitBLT engine to read the source data from the frame buffer at the location specified in BR06.

1: Configures the BitBLT engine to accept the source data from the host CPU via the BitBLT data port. The host CPU provides the source data by performing a series of memory write operations to the BitBLT data port.

9-8 Starting Point Select

These two bits are used to select which of the four corners to use as the starting point in reading and writing graphics data in a BitBLT operation. Normally, the upper left corner is used. However, situations involving an overlap of source and destination locations (this usually occurs when the source and destination locations are both on-screen) often require the use of a different corner as a starting point. It should be remembered that the addresses specified for each piece of graphics data used in a BitBLT operation must point to the byte(s) corresponding to whichever pixel is at the selected starting point. If the starting point is changed, then these addresses must also be changed. See the chapter on the BitBLT engine for more information.

Bit 9 8	Corner Selected as the Starting Point
0 0	Upper Left Corner -- This is the default after reset.
0 1	Upper Right Corner
1 0	Lower Left Corner
1 1	Lower Right Corner

7-0 Bit-Wise Operation Select

These 8 bits are meant to be programmed with an 8-bit code that selects which one of 256 possible bit-wise operations is to be performed by the BitBLT engine during a BitBLT operation. These 256 possible bit-wise operations and their corresponding 8-bit codes are designed to be compatible with the manner in which raster operations are specified in the standard BitBLT parameter block normally used in the Microsoft Windows environment, without translation. See the section on the BitBLT engine for more information.

Note: Bit 12 of this register must be set to 0 whenever a bit-wise operation is selected that does not use source data.

BR05 Pattern Address Register

read/write at memory space offset 0x400014h

word or doubleword accessible

31	30	29	28	27	26	25	24	23	22	21	20	19	18	17	16
Reserved (0000:0000:000)											Pattern Address Bits 20-16 (x:xxxx)				
15	14	13	12	11	10	9	8	7	6	5	4	3	2	1	0
Pattern Address Bits 15-3 (xxxx:xxxx:xxxx:x)												Reserved (000)			

31-21 Reserved (Writable)

These bits should always be written with the value of 0.

20-3 Pattern Address

These bits specify the starting address of the pattern data within the frame buffer as an offset from the beginning of the frame buffer to where the first byte of pattern data is located.

The pattern data is always an 8x8 array of pixels that is always stored in frame buffer memory as a single contiguous block of bytes. The pattern data must be located on a boundary within the frame buffer that is equivalent to its size, and its size depends on the pattern data's color depth. The color depth may be 1 bit per pixel if the pattern data is monochrome or it may be 8, 16, or 24 bits per pixel if the pattern data is in color (the color depth of a color pattern must match the color depth to which the BitBLT engine has been set). Monochrome patterns require 8 bytes, and so the pattern data must start on a quadword boundary. Color patterns of 8, 16, and 24 bits per pixel color depth must start on 64-byte, 128-byte, and 256-byte boundaries, respectively.

Note: In the case of 24 bits per pixel, each row of 8 pixels of pattern data takes up 32 consecutive bytes, not 24. The pattern data is formatted so that for each row there is a block of 8 sets of 3 bytes (each set corresponding to one of the 8 pixels), followed by a block of the 8 extra bytes. When the BitBLT engine reads 24 bit-per-pixel pattern data, it will read only the first 24 bytes of each row of pattern data, picking up only the 8 sets of 3 bytes for the 8 pixels in that row, and entirely ignoring the remaining 8 bytes.

2-0 Reserved

These bits always return 0 when read.

BR06 Source Address Register

read/write at memory space offset 0x400018h

word or doubleword accessible

31	30	29	28	27	26	25	24	23	22	21	20	19	18	17	16
Reserved (0000:0000:000)											Source Address Bits 20-16 (x:xxxx)				
15	14	13	12	11	10	9	8	7	6	5	4	3	2	1	0
Source Address Bits 15-0 (xxxx:xxxx:xxxx:xxxx)															

Important: This register should never be read while the BitBLT engine is busy.

31-21 Reserved (Writable)

These bits should always be written with the value of 0.

20-0 Source Address

When the source data is located within the frame buffer, these bits are used to specify the starting address of the source data within the frame buffer as an offset from the beginning of the frame buffer to where the first byte of source data is located.

When the source data is provided by the host CPU through the BitBLT data port, and that source data is in color, only bits 2-0 are used and the upper bits are ignored. These lower 3 bits are used to indicate the position of the first valid byte within the first quadword of the source data.

When the source data is provided by the host CPU through the BitBLT data port, and that source data is monochrome, the BitBLT engine ignores this register entirely.

BR07 Destination Address Register

read/write at memory space offset 0x40001Ch

word or doubleword accessible

31	30	29	28	27	26	25	24	23	22	21	20	19	18	17	16
Reserved (0000:0000:000)											Destination Address Bits 20-16 (x:xxxx)				
15	14	13	12	11	10	9	8	7	6	5	4	3	2	1	0
Destination Address Bits 15-0 (xxxx:xxxx:xxxx:xxxx)															

Important: This register should never be read while the BitBLT engine is busy.

31-21 Reserved (Writable)

These bits should always be written with the value of 0.

20-0 Destination Address

These bits are used to specify the starting address of the destination location within the frame buffer as an offset from the beginning of the frame buffer to where the first byte of the destination location.

The destination location is where from which destination input data (if used) will be read, and it is where the destination output data will be written.

BR08 Destination Width & Height Register

read/write at memory space offset 0x400020h

word or doubleword accessible

31	30	29	28	27	26	25	24	23	22	21	20	19	18	17	16
Reserved (000)			Destination Scanline Height (0:0000:0000:0000)												
15	14	13	12	11	10	9	8	7	6	5	4	3	2	1	0
Reserved (000)			Destination Byte Width (0:0000:0000:0000)												

Important: This register should never be read while the BitBLT engine is busy.

31-29 Reserved

These bits always return 0 when read.

28-16 Destination Scanline Height

These 13 bits specify the height of the destination input and output data in terms of the number of scanlines.

15-13 Reserved

These bits always return 0 when read.

12-0 Destination Byte Width

These 13 bits specify the width of the destination input and output data in terms of the number of bytes per scanline's worth. The number of pixels per scanline into which this value translates depends upon the color depth to which the BitBLT engine has been set.

BR09 Source Expansion Background Color & Transparency Key Register

read/write at memory space offset 0x400024h
word or doubleword accessible

31	30	29	28	27	26	25	24	23	22	21	20	19	18	17	16
Reserved (0000:0000)								Src Expansion Background Color & Transparency Key Bits 23-16 (xxxx:xxxx)							
15	14	13	12	11	10	9	8	7	6	5	4	3	2	1	0
Source Expansion Background Color & Transparency Key Bits 15-0 (xxxx:xxxx:xxxx:xxxx)															

31-24 Reserved

These bits always return 0 when read.

23-0 Source Expansion Background Color & Transparency Key Bits 23-0

These 24 bits are optionally used to specify the background color for the color expansion of monochrome source data (depending on the setting of bit 27 of BR03). When bit 27 of BR03 is set so that this register is used in the color expansion of monochrome source data, BR01 is used to specify the background color for the color expansion of monochrome pattern data.

These 24 bits are also optionally used to specify the key color for whichever form of color transparency is selected via bits 16-15 of BR04 (depending on the setting of bit 27 of BR03).

Whether bits 7-0, 15-0 or 23-0 of this register are used in both the color expansion and color transparency processes depends upon the color depth to which the BitBLT engine has been set.

BR0A Source Expansion Foreground Color Register

read/write at memory space offset 0x400028h

word or doubleword accessible

31	30	29	28	27	26	25	24	23	22	21	20	19	18	17	16
Reserved (0000:0000)								Source Expansion Foreground Color Bits 23-16 (xxxx:xxxx)							
15	14	13	12	11	10	9	8	7	6	5	4	3	2	1	0
Source Expansion Foreground Color Bits 15-0 (xxxx:xxxx:xxxx:xxxx)															

31-24 Reserved

These bits always return 0 when read.

23-0 Pattern/Source Expansion Foreground Color Bits 23-0

These 24 bits are optionally used to specify the foreground color for the color expansion of monochrome source data (depending on the setting of bit 27 of BR03). When bit 27 of BR03 is set so that this register is used in the color expansion of monochrome source data, BR02 is used to specify the foreground color for the color expansion of monochrome pattern data.

Whether bits 7-0, 15-0 or 23-0 of this register are used in the color expansion process depends upon the color depth to which the BitBLT engine has been set.

Chapter 18

Memory-Mapped Wide Extension Registers

The video decoder registers are 32-bit memory-mapped registers that exist in the upper memory space that the 69000 occupies on the host bus. Refer to chapter on address maps for more information. These registers exist at an offset of 0x400100h from the base address of the memory space.

Name	Function	Access	Offset
ER00	Central Interrupt Control Register	read/write	0x400100
ER01	Central Interrupt Status Register	read/write	0x400104
ER03	Miscellaneous Function Register	read/write	0x40010C

ER00 Central Interrupt Control Register

read/write at memory space offset 0x400100h

word or doubleword accessible

31	30	29	28	27	26	25	24	23	22	21	20	19	18	17	16
BBLT Idle Int Output En (0)	Rsvrd (0)	Reserved (00:0000:0000:0000)													

15	14	13	12	11	10	9	8	7	6	5	4	3	2	1	0	
Rsvrd (0)	Dsply VBlnk Int Output En (0)	Reserved (00:0000:0)							V Cap VSync Int Output En (0)	Reserved (00:0000)						

31 BitBLT Engine Idle Interrupt Output Enable

0: No hardware interrupt is output to the host when the BitBLT engine becomes idle after performing a BitBLT operation.

1: Causes a hardware interrupt to be output to the host when the BitBLT engine becomes idle after performing a BitBLT operation.

30 Reserved

This bit always returns a value of 0 when read.

29-15 Reserved

These bits always return the value of 0 when read.

14 Display Vertical Blanking Period Interrupt Output Enable

0: No hardware interrupt is output to the host when the last pixel of the last scan line within the active display area is drawn on pipeline A.

1: Causes a hardware interrupt to be output to the host when the last pixel of the last scan line within the active display area is drawn on pipeline A.

13-7 Reserved

These bits always return the value of 0 when read.

6 Video Capture Vertical Sync Interrupt Output Enable

0: No hardware interrupt is output to the host at the start of each vertical sync pulse from the acquisition data source.

1: Causes a hardware interrupt to be output to the host at the start of each vertical sync pulse from the acquisition data source.

5-0 Reserved

These bits always return the value of 0 when read.

ER01 Central Interrupt Status/Acknowledge Register

read/write at memory space offset 0x400104h

word or doubleword accessible

31	30	29	28	27	26	25	24	23	22	21	20	19	18	17	16	
BBLT Idle (0)	Reserved (00:0000:0000:0000)															
15	14	13	12	11	10	9	8	7	6	5	4	3	2	1	0	
Rsvd (0)	Pipe A V Blink (0)	Reserved (00:0000:0)							V Cap VSync (0)	Reserved (00:0000)						

31 BitBLT Engine Idle Interrupt Pending

0: Since this bit was last cleared, no interrupt has been sourced as a result of the BitBLT engine becoming idle after performing a BitBLT operation.

1: An interrupt was sourced as a result of the BitBLT engine becoming idle after performing a BitBLT operation. Writing the value of 1 to this bit will clear it to 0 (writing the value of 0 to this bit has no effect and will be ignored).

30 Reserved

These bits always return the value of 0 when read.

29-15 Reserved

These bits always return the value of 0 when read.

14 Display Vertical Blanking Period Interrupt Pending

0: Since this bit was last cleared, no interrupt has been sourced as a result of the drawing of the last scan line within the active display area on pipeline A.

1: An interrupt was sourced as a result of the drawing of the last scan line within the active display area on pipeline A. Writing the value of 1 to this bit will clear it to 0 (writing the value of 0 to this bit has no effect and will be ignored).

13-7 Reserved

These bits always return the value of 0 when read.

6 Video Capture Vertical Sync Interrupt Pending

0: Since this bit was last cleared, no interrupt has been sourced as a result of the start of a vertical sync pulse from the acquisition data source.

1: An interrupt was sourced as a result of the start of a vertical sync pulse from the acquisition data source. Writing the value of 1 to this bit will clear it to 0 (writing the value of 0 to this bit has no effect and will be ignored).

5-0 Reserved

These bits always return the value of 0 when read.

ER03 Miscellaneous Function Register

read/write at memory space offset 0x40010Ch

word or doubleword accessible

31	30	29	28	27	26	25	24	23	22	21	20	19	18	17	16
Reserved															
(0000:0000:0000:0000)															

15	14	13	12	11	10	9	8	7	6	5	4	3	2	1	0	
Rsvd	Dsply Vert Blnk Pol	Reserved							VCap VSync Int Pol	Reserved						
(0)	(0)	(00:0000:0)							(0)	(00:0000)						

32-15 Reserved

This bit always returns the value of 0 when read.

14 Display Vertical Blanking Period Interrupt Source Polarity

0: No inversion.

1: Inversion.

13-7 Reserved

These bits always return the value of 0 when read.

6 Video Capture Vertical Sync Interrupt Source Polarity

0: No inversion.

1: Inversion.

5-0 Reserved

These bits always return the value of 0 when read.

Appendix A

DISPLAY MODES

This chapter lists tables for configuring the 69000 for various CRT monitor and flat panel graphics and text display modes. The parameters detailed in the tables of this chapter define standard capabilities of the 69000 when it is used with the Chips VGA BIOS. Consult with the appropriate BIOS vendor for information about display modes and parameters that are supported by BIOSs that are not from Chips.

The following symbols and abbreviations are used for display modes in the following sections:

–	Indicates CGA display mode (Table A-1 only.)
*	EGA display mode. (Table A-1 only.)
+	VGA display mode. (Table A-1 only.)
DSTN	Dual-scan STN flat panel
I	Interlaced
L	Linear mapped
P	Page mapped

CRT-Only Display Modes

This section lists tables for standard VGA and Chips Extended VGA CRT-only display modes.

Standard VGA CRT-Only Display Modes

The 69000 VGA BIOS supports all standard VGA CRT-only display modes, listed below.

Table A-1: Standard VGA CRT-Only Display Modes

Standard VGA Display Mode No. (hex)	VESA Display Mode Number	Color Resolution (bpp/ # colors)	Characters X Rows	Character Cell (pixels)	Resolution (pixels)	Type of Display Mode	Horizontal Frequency (kHz)	Vertical Frequency (Hz)
00, 01	–	16/256K	40 × 25	8 × 8	320 × 200	Text	31.5	70
00*, 01*	–	16/256K	40 × 25	8 × 14	320 × 350	Text	31.5	70
00+, 01+	–	16/256K	40 × 25	9 × 16	360 × 400	Text	31.5	70
02, 03	–	16/256K	80 × 25	8 × 8	640 × 200	Text	31.5	70
02*, 03*	–	16/256K	80 × 25	8 × 14	640 × 350	Text	31.5	70
02+, 03+	–	16/256K	80 × 25	9 × 16	720 × 400	Text	31.5	70
04, 05	–	4/256K	40 × 25	8 × 8	320 × 200	Graphics	31.5	70
06	–	2/256K	80 × 25	8 × 8	640 × 200	Graphics	31.5	70
07*	–	Mono-chrome	80 × 25	9 × 14	720 × 350	Text	31.5	70
07+	–	Mono-chrome	80 × 25	9 × 16	720 × 400	Text	31.5	70
0D	–	16/256K	40 × 25	8 × 8	320 × 200	Graphics	31.5	70
0E	–	16/256K	80 × 25	8 × 8	640 × 200	Graphics	31.5	70
0F	–	Mono	80 × 25	8 × 14	640 × 350	Graphics	31.5	70
10	–	16/256K	80 × 25	8 × 14	640 × 350	Graphics	31.5	70
11	–	2/256K	80 × 30	8 × 16	640 × 480	Graphics	31.5	60
12	–	16/256K	80 × 30	8 × 16	640 × 480	Graphics	31.5	60
13	–	256/256K	40 × 25	8 × 8	320 × 200	Graphics	31.5	70

Chips Extended VGA CRT-Only Display Modes

Table A-2 shows the extended VGA and VESA display modes that the 69000 VGA BIOS supports. Within the table:

- The 'Minimum MCLK' column gives the recommended memory clock frequency at which the 69000 can run without adverse effects to functionality. Better benchmarks can be achieved with an MCLK frequency higher than the frequency specified.
- Some of the display modes are not supported by all CRT monitors.

Table A-2: Extended VGA CRT-Only Display Modes

Extended VGA Display Mode No. (hex)	VESA Display Mode No. (hex)	Color Depth (bits per pixel)	Memory Organization	Resolution (pixels)	Horizontal Freq. (kHz)	Vertical Freq. (Hz)	VCLK (MHz)	Minimum MCLK (MHz)
14h	–	8	Packed Pixel	320 × 200	31.5	70	12.587	50
15h		16			31.5	70	12.587	50
16h		24			31.5	70	12.587	50
17h	–	8	Packed Pixel	320 × 240	31.5	60	12.587	50
18h		16			31.5	60	12.587	50
19h		24			31.5	60	12.587	50
1Ah	–	8	Packed Pixel	400 × 300	37.5	60	20	50
1Bh		16			37.5	60	20	50
1Ch		24			37.5	60	20	50
1Dh	–		Packed Pixel	512 × 384	48.4	60	32.5	50
1Eh	–	256/256K			48.4	60	32.5	50
1Fh	–				48.4	60	32.5	50
31h	100h	8	Packed Pixel	640 × 400	31.5	70	25.175	50
62h	–	16			31.5	70	25.175	50
63h	–	24			31.5	70	25.175	50
20h	120h	4	Packed Pixel	640 × 480	31.5	60	25.175	50
					37.5	75	31.5	50
					43.3	85	36	50
22h	122h	4	Packed Pixel	800 × 600	35.5	56	36	50
					46.9	60	40	50
					46.9	75	49.5	50
					53.7	85	56.25	50
6Ah	102	4	Planar	800 × 600	31.5	56	36	50
					37.9	60	40	50
					46.9	75	49.5	50
					53.7	85	56.25	50

Extended VGA Display Mode No. (hex)	VESA Display Mode No. (hex)	Color Depth (bits per pixel)	Memory Organization	Resolution (pixels)	Horizontal Freq. (kHz)	Vertical Freq. (Hz)	VCLK (MHz)	Minimum MCLK (MHz)
24h	102h	4	Packed Pixel	800 x 600	31.5	60	25	50
					37.9	72	31.5	50
					37.5	75	31.5	50
					43.269	85	36	50
64h	104h	4	Planar	1024 x 768	35.5	43(l)	44.9	50
					48.4	60	65	50
					60	75	78.75	50
					68.7	85	94.5	50
28h	128h	4	Packed Pixel	1280 x 1024	47	43(l)	78.75	50
					64	60	108	50
					79.98	75	135	50
68h	106h	4	Planar	1280 x 1024	47	43(l)	78.75	50
					64	60	108	50
					79.98	75	135	50
30h(L) 70h(P)	101h	8	Packed Pixel	640 x 480	31.5	60	25.175	50
					37.5	75	31.5	50
					43.3	85	36	50
31h(L) 71h(P)	100h	8	Packed Pixel	640 x 400	31.5	70	25.175	50
32h(L) 72h(P)	103h	8	Packed Pixel	800 x 600	35.1	56	36	50
					37.9	60	40	50
					46.9	75	49.5	58
					53.7	85	56.25	68
34h(L) 74h(P)	105h	8	Packed Pixel	1024 x 768	35.5	43(l)	44.9	50
					48.4	60	65	60
					60	75	78.75	80
					68.7	85	94.5	80
36h	–	8	Packed Pixel	Generic	–	–	–	–
38h(L) 78h(P)	107h	8	Packed Pixel	1280 x 1024	47	43(l)	78.75	50
					64	60	108	50
					79.98	75	135	50

Extended VGA Display Mode No. (hex)	VESA Display Mode No. (hex)	Color Depth (bits per pixel)	Memory Organiza- tion	Resolution (pixels)	Horizontal Freq. (kHz)	Vertical Freq. (Hz)	VCLK (MHz)	Mini- mum MCLK (MHz)
41h	111h	16	Packed Pixel	640 x 480	31.5	60	25.175	50
					37.5	75	31.5	50
					43.3	85	36	50
43h	114h	16	Packed Pixel	800 x 600	35.1	56	36	50
					37.9	60	40	50
					46.9	75	49.5	60
					53.7	85	56.25	70
45h	117h	16	Packed Pixel	1024 x 768	35.5	43(l)	44.9	50
					48.4	60	65	50
					60	75	78.75	50
					68.7	85	94.5	50
47h	–	16	Packed Pixel	Generic	–	–	–	–
50h	112h	24	Packed Pixel	640 x 480	31.5	60	25.175	50
					37.5	75	31.5	50
					43.3	85	36	50
52h	115h	24	Packed Pixel	800 x 600	35.5	56	36	50
					37.9	60	40	50
					46.9	75	49.5	50
					53.7	85	56.25	50
56h	–	24	Packed Pixel	Generic	–	–	–	–

Display Modes

The 69000 VGA BIOS supports flat panel-only and simultaneous operations with the standard VGA display modes listed in here and elsewhere. In addition, the 69000 VGA BIOS supports flat panel-only and simultaneous operations with the extended display modes listed in this section.

Flat Panel-Only and Simultaneous 640x480 (VGA) Display Modes

For 640 x 480 flat panels, the Chips VGA BIOS supports flat panel-only and simultaneous operations with the standard VGA display modes listed in Table A-1 and the extended VGA display modes in Table A-3.

- Within the table, the 'Minimum MCLK' column gives the recommended memory clock frequency at which the 69000 can run without adverse effects to functionality. Better benchmarks can be achieved with an MCLK frequency higher than the frequency specified.
- DSTN flat panels require display memory for frame accelerator functionality.
- For simultaneous operation, both the flat panel and the CRT monitor must be configured at a minimum to support the resolution of a given display mode.

Table A-3: Flat Panel-Only and Simultaneous 640x480 (VGA) Display Modes

Extended VGA Display Mode Number (hex)	VESA Display Mode Number (hex)	Color Depth (bits per pixel)	Resolution (pixels)	Type of Flat Panel	VCLK (MHz)	Minimum MCLK(MHz)
20h	120h	4	640 × 400	DSTN/TFT	25	50
30h	101h	8	640 × 480	DSTN/TFT	25	50
41h	111h	16	640 × 480	DSTN/TFT	25	50
50h	112h	24	640 × 480	DSTN/TFT	25	50

Flat Panel-Only and Simultaneous 800x600 (SVGA) Display Modes

For 800x600 flat panels, the Chips VGA BIOS supports flat panel-only and simultaneous operations with the standard VGA display modes listed in Table A-1 and the extended VGA display modes in Table A-4.

- Within the table, the 'Minimum MCLK' column gives the recommended memory clock frequency at which the 69000 can run without adverse effects to functionality. Better benchmarks can be achieved with an MCLK frequency higher than the frequency specified.
- DSTN flat panels require display memory for frame accelerator functionality.
- For simultaneous operation, both the flat panel and the CRT monitor must be configured at a minimum to support the resolution of a given display mode.

Table A-4: Flat Panel-Only and Simultaneous Display Modes for 800x600 Flat Panels.

Extended VGA Display Mode No. (hex)	VESA Display Mode No. (hex)	Color Depth (bits per pixel)	Resolution (pixels)	Type of Flat Panel	VCLK (MHz)	Minimum MCLK (MHz)
22h	122h	4	800 × 600	DSTN	40	50
				TFT	40	50
6Ah ^a	102h	4	800 × 600	DSTN	40	50
				TFT	40	50
32h	103h	8	800 × 600	DSTN	40	50
				TFT	40	50
43h	114h	16	800 × 600	DSTN	40	50
				TFT	40	50
52h	115h	24	800 × 600	DSTN	40	50
				TFT	40	50

a- planar mode

Flat Panel-Only and Simultaneous 1024x768 Display Modes

For 1024x768 flat panels, the Chips VGA BIOS supports flat panel-only and simultaneous operations with the standard VGA display modes listed in Table A-1 and the extended VGA display modes in Table A-5.

- Within the table, the 'Minimum MCLK' column gives the recommended memory clock frequency at which the 69000 can run without adverse effects to functionality. Better benchmarks can be achieved with an MCLK frequency higher than the frequency specified.
- DSTN flat panels require display memory for frame accelerator functionality.
- For simultaneous operation, both the flat panel and the CRT monitor must be configured at a minimum to support the resolution of a given display mode.

Table A-5: Flat Panel-Only and Simultaneous Display Modes for 1024x768 Flat Panels

Extended VGA Display Mode Number (hex)	VESA Display Mode Number (hex)	Color Depth (bits per pixel)	Resolution (pixels)	Type of Flat Panel	VCLK (MHz)	Minimum MCLK (MHz)
24h	124h	4	1024 × 768	DSTN	65	58
				TFT		
64h ^a	104h	4	1024 × 768	DSTN	65	58
				TFT		
34h	105h	8	1024 × 768	DSTN	65	58
				TFT		
45h	117h	16	1024 × 768	DSTN	65	58
				TFT		

a- planar mode

Flat Panel-Only and Simultaneous 1280x1024 Display Modes

For 1280x1024 flat panels, the Chips VGA BIOS supports flat panel-only and simultaneous operations with the standard VGA display modes listed in Table A-1 and the extended VGA display modes in Table A-6.

- Within the table, the 'Minimum MCLK' column gives the recommended memory clock frequency at which the 69000 can run without adverse effects to functionality. Better benchmarks can be achieved with an MCLK frequency higher than the frequency specified.
- DSTN flat panels require display memory for frame accelerator functionality.
- For simultaneous operation, both the flat panel and the CRT monitor must be configured at a minimum to support the resolution of a given display mode.

Table A-6: Flat Panel-Only and Simultaneous Display Modes for 1280x1024 Flat Panels

Extended VGA Display Mode Number (hex)	VESA Display Mode Number (hex)	Color Depth (bits per pixel)	Resolution (pixels)	Type of Flat Panel	VCLK (MHz)	Minimum MCLK (MHz)
28h	128h	4	1280 x 1024	DSTN	108	50
				TFT		
68h ^a	106h	4	1280 x 1024	DSTN	108	50
				TFT		
38h	107h	8	1280 x 1024	TFT	108	50

a- planar mode

Appendix B

Clock Generation

Clock Synthesizer

The graphics controller contains two complete phase-locked loops (PLLs) to synthesize the internal Dot Clock (DCLK) and Memory Clock (MCLK) from an externally supplied reference frequency. Each of the two clock synthesizer phase lock loops may be programmed to output frequencies ranging between 3MHz and the maximum specified operating frequency for that clock in increments not exceeding 0.5%. An external crystal-controlled oscillator (TTL) generates the reference frequency of 14.31818 MHz that is driven into the graphics controller on pin C3. The graphics controller can not generate the 14.31818 MHz reference frequency using only an external crystal.

Dot Clock (DCLK)

The dot clock is used as the basis for all display timings. The horizontal and vertical sync frequencies are derived by dividing down the dot clock.

In borrowing from VGA parlance, there are said to be three dot clocks: DCLK0, DCLK1 and DCLK2. In truth, there is actually only a single PLL, but it can be configured with divisor values from any one of three sets of registers within the XRC0-XRCF group of registers, and these three groups of registers are referred to as if they were DCLK0, DCLK1 and DCLK2. Bits 3 and 2 of the Miscellaneous Output Register (MSR) are used to select which one of these 3 sets of registers will be used to supply the divisor values that the PLL will use in creating the dot clock at any given time.

During reset, the first two sets of these registers (DCLK0 and DCLK1) default to values that specify the two standard VGA dot clocks of 25.175MHz and 28.322MHz, and normally the values in these first two sets of registers are not changed. The third set of registers (DCLK2) is used for all modes that are not of the VGA standard, i.e., the extended modes.

Memory Clock (MCLK)

The memory clock is used as the basis for all memory timings. It is normally set once following hardware reset, and is not normally modified again.

PLL Parameters

Each phase-locked loop consists of the elements shown in the figure below. The reference input frequency (14.31818MHz) is divided by N, a 8-bit programmable value. The output of the VCO is divided by 1 (or 4 via the VCO Loop Divider: VLD) and then further divided by M, another 8-bit programmable value. The phase detector compares the N and M results and adjusts the VCO frequency as needed to achieve frequency equality.

When the loop has stabilized, the VCO frequency (F_{VCO}) is related to the reference as follows:

$$\begin{array}{l} \text{If VLD=1:} \\ \text{If VLD=4:} \\ \text{(DCLK only)} \end{array} \quad \text{or} \quad \begin{array}{l} F_{VCO} / M = F_{REF} / N \\ F_{VCO} / 4M = F_{REF} / N. \end{array}$$

For VLD =1, the F_{VCO} can be written as:

$$F_{VCO} = (F_{REF} * M / N)$$

The VCO output can be further divided by 1, 2, 4, 8, 16, or 32 (which is called Post Divisor: PD) to produce the final DCLK or MCLK used for video or memory timing.

Therefore the output frequency is:

$$F_{OUT} = (F_{VCO})/PD$$

By “fine tuning” the M/N ratio in each PLL, extremely small adjustments in the exact DCLK and MCLK frequencies can be achieved. The VCO itself is designed to operate in the range of 100MHz to 220 MHz.

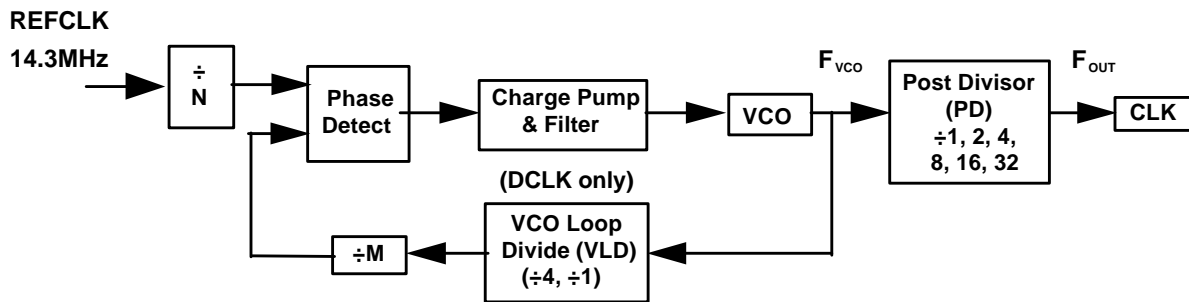

M counter = Program value M'+2

N counter = Program value N'+2

F_{VCO} : VCO frequency (before post divisor)

F_{OUT} : Output frequency: (desired frequency)

Figure B-1: PLL Elements

Programming the Clock Synthesizer

Below are the register tables for CLK0, CLK1, CLK2, and MCLK. Please see the block diagram for M, N, and Post Divide (PD).

	CLK0	CLK1
M	XRC0	XRC4
N	XRC1	XRC5
VLD	XRC3[2]	XRC7[2]
PD	XRC3[6:4]	XRC7[6:4]

	CLK2	MCLK
M	XRC8	XRCC[7:0]
N	XRC9	XRCD[7:0]
VLD	XRCB[2]	
PD	XRCB[6:4]	XRCE[6:4]

DCLK Programming

For each DCLK, a new frequency should be programmed by following below sequence:

- 1) Program M
 - 2) Program N
 - 3) Program PD
- This will effectively change DCLK into the new frequency

MCLK Programming

For MCLK, a new frequency should be programmed by following the sequence below:

- 1) Program M
- 2) Program N
- 3) Program PD

Programming Constraints

The programmer must be aware of the following five programming constraints:

$$1 \text{ MHz} \leq F_{\text{REF}} \leq 83 \text{ MHz}$$

$$150 \text{ KHz} \leq F_{\text{REF}} / (N) \leq 5 \text{ MHz}$$

$$100 \text{ MHz} \leq F_{\text{VCO}} \leq 220 \text{ MHz}$$

$$3 \leq M \leq 257$$

$$3 \leq N \leq 257$$

The constraints have to do with trade-offs between optimum speed with lowest noise, VCO stability and factors affecting the loop equation.

The value of F_{VCO} must remain between 100 MHz and 220 MHz inclusive. Therefore, for output frequencies below 100 MHz, F_{VCO} must be brought into range by using the post-VCO Divisor.

To avoid crosstalk between the VCOs, the VCO frequencies should not be within 0.5% of each other nor should their harmonics be within 0.5% of the other's fundamental frequency.

The graphics controller's clock synthesizers will seek the new frequency as soon as it is loaded following a write to the control register. Any change in the post-divisor will take affect immediately. The output may glitch during this transition of post divide values. Therefore, the programmer may wish to hold the post-divisor value constant across a range of frequencies. There is also the consideration of changing from a low frequency VCO value with a post-divide $\div 1$ (e.g., 100 MHz) to a high frequency $\div 4$ (e.g., 220 MHz). Although the beginning and ending frequencies are close together, the intermediate frequencies may cause the graphics controller to fail in some environments. In this example, there will be a short-lived time during which the output frequency will be approximately 12.5 MHz. The graphics controller provides the mux for MCLK so it can select the fixed frequency (25.175 MHz) before programming a new frequency. Because of this, the bus interface may not function correctly if the MCLK frequency falls below a certain value. Register and memory accesses synchronized to MCLK may be too slow and violate the bus timing causing a watchdog timer error.

Programming Example

The following is an example of the calculations which are performed.

Derive the proper programming word for a 25.175 MHz output frequency using a 14.31818 MHz reference frequency.

Since $25.175 \text{ MHz} < 100 \text{ MHz}$, quadruple it to 100.70 MHz to get F_{VCO} in its valid range.
Set the post divide (PD) divide by 4.
Video Loop Divisor Selector (VLD) = 1

The result: $F_{\text{VCO}} = 100.70 = (14.31818 \times M/N)$
 $M/N = 7.0330$

Several choices for M and N are available:

M	N	F_{VCO}	Error
211	30	100.70	-0.00005
204	29	100.72	+0.00021

Choose (M, N) = (211, 30) for best accuracy.

$$F_{REF} / (RDS \times N) = 157.3\text{KHz}$$

$$M/N = 0.879127$$

Therefore M is less than 255 and VLD = 1, P = 4.

$$XRC0 = 211 - 2 = 209 \text{ (D1h)}$$

$$XRC1 = 30 - 2 = 28 \text{ (1Eh)}$$

$$XRC3 = 0010\ 0100 = 24\text{h}$$

PCB Layout Considerations

Clock synthesizers, like most analog components, must be isolated from the noise that exists on a PCB power plane. Care must be taken not to route any high frequency digital signals in close proximity to the analog sections. Inside the graphics controller chip, the clocks are physically located in the lower left corner of the chip surrounded by low frequency input and output pins. This helps to minimize both internally and externally coupled noise.

The memory clock and video clock power pins on the graphics controller chip each require similar RC filtering to isolate the synthesizers from the V_{CC} plane and from each other. The filter circuit for each CVCCn/CGND pair is shown below:

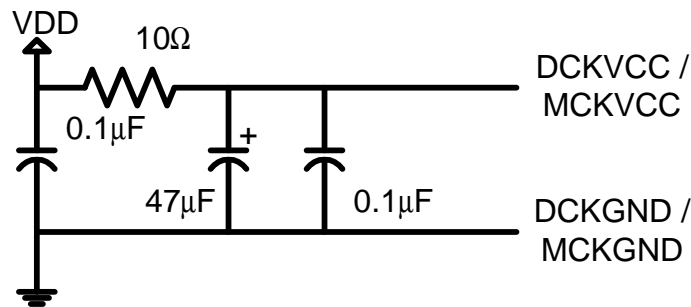

The suggested method for layout assumes a multi-layer board including VCC and GND planes. All ground connections should be made as close to the pin/component as possible. The CVCC trace should route from the graphics controller through the pads of the filter components. The trace should NOT be connected to the filter components by a stub. All components (particularly the nearest 0.1μF capacitor) should be placed as close as possible to the graphics controller.

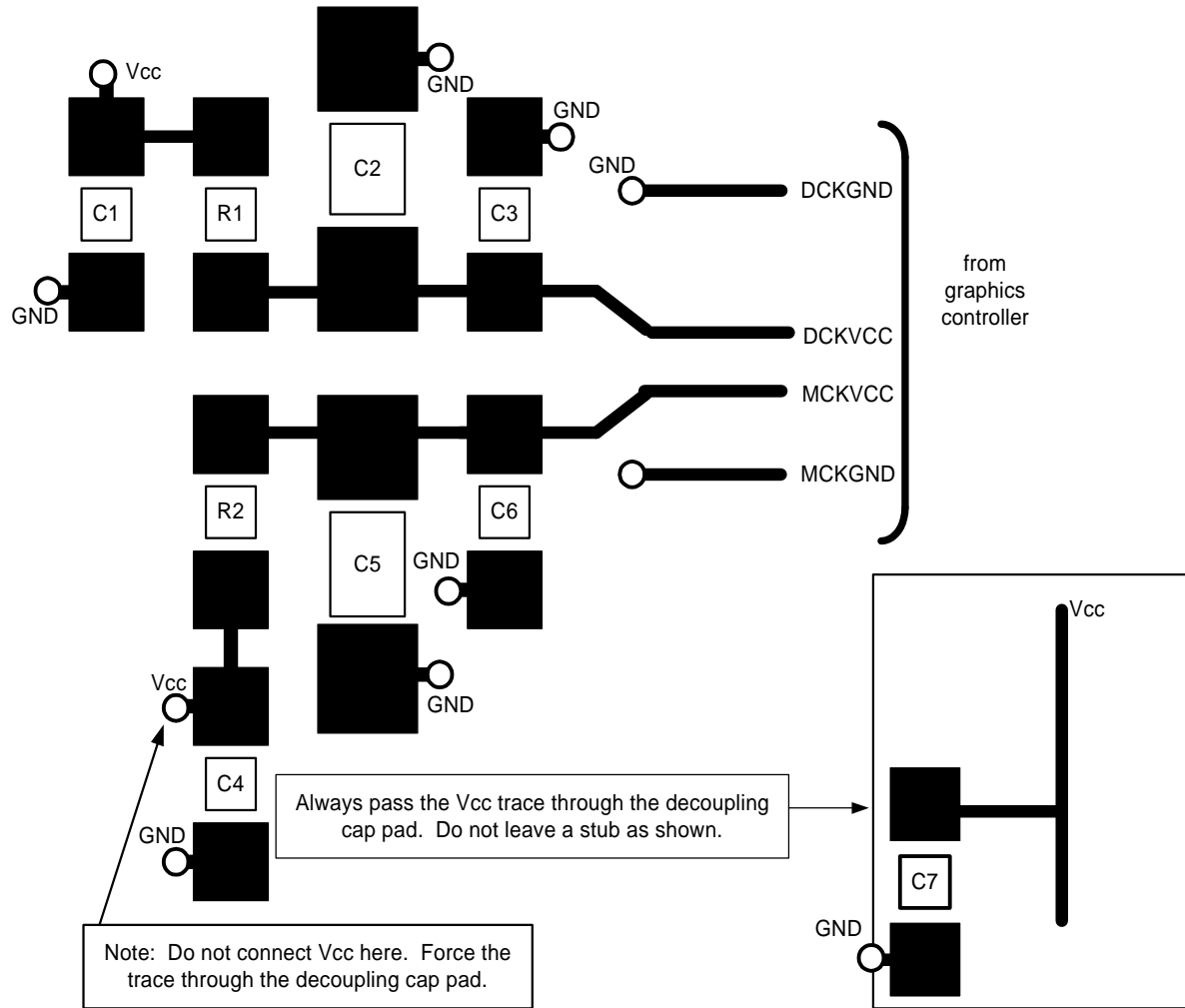

Display Memory Bandwidth

The graphics controller's ability to support high performance Super VGA modes can be limited by display memory bandwidth as well as the maximum allowable DCLK frequency. The maximum pixel rate that a given MCLK frequency can support depends on the following:

- 1) Pixel depth (number of bytes per pixel): 1 byte for 8 bpp, 2 bytes for 16 bpp, 3 bytes for 24 bpp.
- 2) Number of additional bytes accessed for STN-DD frame buffering, usually one byte per pixel (independent of pixel depth in main display memory). This effect is discussed further in the next section. It applies only to STN-DD panels, not to CRT or TFT displays.
- 3) Utilization efficiency. The percentage of peak memory bandwidth needed for RAS overhead (RAS-CAS cycles rather than CAS-only cycles), DRAM refresh, and CPU access. Peak memory bandwidth is the product of MCLK and the number of bytes accessed per MCLK (e.g., 800 MB/sec for 83 MHz MCLK). The graphics controller needs at least 20% of this peak bandwidth for RAS overhead (higher for STN-DD buffer accesses and CPU accesses due to shorter DRAM bursts). Allow at least an additional 10% bandwidth buffer for CPU accesses and DRAM refresh. This leaves 70% of MCLK cycles available for display refresh (10% allowance for the CPU may be grossly inadequate for demanding applications such as software MPEG playback).
- 4) Multimedia frame capture. This factor is not included in the example calculations. Except where otherwise noted, the graphics controller mode support estimates do not include provision for frame capture from the video input port.

As an example, suppose MCLK is 83 MHz and the pixel depth is 16 bpp. Then the maximum supportable pixel rate for CRT and TFT displays is $40 \text{ MHz} \times 70\% \times 8 \div 2 = 112 \text{ MHz}$ (8 bytes per MCLK, 2 bytes per pixel). Any video mode that uses a 112 MHz or lower DCLK can be supported by the 40 MHz MCLK. For an STN-DD panel, the maximum supportable pixel rate in 16 bpp modes is $40 \text{ MHz} \times 70\% \times 8 \div 3 = 75 \text{ MHz}$ (8 bytes per MCLK, 3 bytes accessed per pixel). 16 bpp video modes using a 75 MHz or lower DCLK can be supported by the 40 MHz MCLK with an STN-DD panel.

STN-DD Panel Buffering

STN-DD panels require the upper and lower halves of the panel to be refreshed simultaneously. In addition, Temporal Modulated Energy Distribution (TMED) or Frame Rate Control (FRC) is needed to achieve more than 8 colors, since the panel itself supports only 3 bits per pixel (one bit each for red, green, and blue). The 69000 implements STN-DD support using either a full frame buffer or a half frame buffer (programmable option). The buffer holds three bits per pixel, packed in groups of 10 pixels per DWORD. Thus, the buffer requires 0.4 bytes per pixel in addition to the main display memory.

The half frame buffer operates as follows. As each pixel is read out of display memory, the appropriate 3-bit code for the panel is calculated and sent to the panel. In addition, the proper 3-bit code for the same pixel in the NEXT frame is also calculated, with allowance for frame rate control. The second 3-bit code is written into the half frame buffer. During this same pixel time, the previously stored 3-bit code is read out of the half frame buffer and sent to the other half of the panel.

The full frame buffer operates in a similar manner. As each two pixels are read out of display memory, the appropriate 3-bit codes for the panel are calculated and stored in the buffer. During the same two pixel times, previously stored 3-bit codes are read out of the buffer and sent to upper and lower halves of the panel.

There is no difference between a half frame buffer and a full frame buffer in the effect on display memory bandwidth. Both options require 0.4 bytes per pixel to be read and written during each pixel time. If the buffer is located in main display memory, the total effect is 0.8 extra bytes of memory access per pixel (regardless of pixel depth). In 16 bpp modes, a total of 2.8 bytes of memory access must be performed per pixel – 2 bytes for the 16 original pixel bits, plus 0.8 byte for the buffer bits. The graphics controller actually reads and writes one DWORD in the buffer for every 10 pixels, which is the same as 0.8 bytes per pixel. For mode support calculations, it is usually best to assume 1.0 byte per pixel instead of 0.8, since the RAS overhead for STN-DD buffer accesses is somewhat higher than for normal pixel accesses due to shorter DRAM bursts.

The half frame buffer has a timing characteristic for the panel that may be either a problem or an advantage, depending on the application. The panel is refreshed at twice the pixel rate imposed on the display memory. In simultaneous CRT and panel mode, this means that the pixel rate is dictated by the CRT requirements, and the panel is refreshed at twice that rate. This may exceed panel timing limitations. However, in panel-only mode, the pixel rate from display memory can be reduced to half of what a CRT would need, which imposes half the burden on display memory bandwidth and allows more complex video modes to be supported by the available display memory bandwidth.

The full frame buffer allows the panel refresh rate to be the same as the CRT in simultaneous display mode, but requires the buffer size to be twice as large (full frame instead of half frame, though only 0.4 bytes per pixel).

Horizontal and Vertical Clocking

Clocking within a horizontal scan line is generally programmed in units of 8 DCLK cycles (8 pixels), often referred to as “character” clocks (for graphics modes as well as text modes). The “character” clocks are numbered from 0 to n-1, where “n” is the total number of character clocks per horizontal scan (including blanking and border intervals as well as the “addressable video” interval). Character clock #0 corresponds to the start of the “addressable video” interval, also known as the “Display Enable” interval. Starting at character clock #0, the following horizontal timing events occur:

- End of Display Enable
- Start of horizontal blanking (end of right border)
- Horizontal sync pulse start and end
- End of horizontal blanking
- Start of left border (This border area is actually for the next physical scan line.)
- End of left border area and start of Display Enable (This corresponds to the “Horizontal Total” parameter.)

Similarly, vertical clocking is generally programmed in units of scan lines, numbered from 0 to m-1, where “m” is the total number of scan lines per complete frame and “0” corresponds to the first scan line containing addressable video information. Starting at scan line #0, the following vertical timing events occur:

- End of addressable video
- Start of vertical blanking (end of bottom border)
- Vertical sync pulse start and end
- End of vertical blanking (start of top border) (This border area is actually for the next physical frame.)
- End of top border area and start of addressable video. This corresponds to the “Vertical Total” parameter.

Vertical timing can also be “interlaced,” meaning that even numbered scan lines are displayed during one vertical sweep and odd numbered lines are displayed during the next vertical sweep. This allows more time (two vertical sweeps instead of one) to display a complete frame, which reduces video bandwidth requirements while preserving a reasonably flicker-free image. North American television standards use a 60 Hz vertical sync frequency, interlaced for a 30 Hz effective frame rate, with 525 scan lines total per frame (even lines plus odd, including blanking). The horizontal sync frequency is $525 \times 30 \text{ Hz} = 15.75 \text{ KHz}$.

To achieve interlacing, the sweep of odd-numbered lines is offset by half of a scan line relative to the sweep of even-numbered lines. The vertical sync pulse for alternate frames occurs in the middle of a scan line interval (during vertical blanking) instead of at the end. North American television standards sweep 262.5 scan lines on each vertical sweep (60Hz). Each scan line remains full length, but the vertical sync for alternating frames occurs at the middle of the scan line. In the 69000, a CHIPS Super VGA extension register allows the exact placement of the half-line vertical sync pulse to be programmable, for optimum centering of odd scan lines between adjacent even scan lines.

Computer CRT displays generally need about 25% of the horizontal total for horizontal border and blanking intervals, and at least 5% of the vertical total for vertical border and blanking. Flat panels typically can operate with smaller margins for these “non-addressable” intervals.

Appendix C

Panel Power Sequencing

Flat panel displays are extremely sensitive to conditions where full biasing voltage VEE is applied to the liquid crystal material without enabling the control and data signals to the panel. This results in severe damage to the panel and may disable the panel permanently.

The graphics controller provides a simple method to provide or remove power to the flat panel display in a sequence of stages when entering various modes of operation to conserve power and provide safe operation to the flat panel.

Three pins called ENAVEE, ENAVDD and ENABKL are provided to regulate the LCD Bias Voltage (VEE), the driver electronics logic voltage (VDD), and the backlight voltage (BKL) to provide intelligent power sequencing to the panel. The delay between each stage in the sequence is programmable via the Panel Power Sequencing Delay Register (FR04).

The graphics controller performs the 'panel off' sequence when the STNDBY# input becomes low, or if bit 3 of the Power Down Control 1 Register (FR05) is set to 1. Conversely, the graphics controller performs the 'panel on' sequence when the STNDBY# input becomes high, or if bit 3 of the Power Down Control 1 Register (FR05) is set to 0.

Appendix D

Hardware Cursor and Pop Up Window

This graphics controller provides a pair of hardware-based cursors, called “cursor 1” and “cursor 2.” Cursor 1 is normally used to provide the arrow pointer in most GUI applications and operating systems. Cursor 2 has no pre-assigned purpose, however it is assumed that it will be usually used to provide some form of pop-up window.

Off-screen memory in the frame buffer is used to provide the locations where the data for both cursor 1 and cursor 2 are kept. This allows each cursor to be displayed and used without altering the main display image stored in the frame buffer. Each cursor may have multiple patterns stored in these off-screen memory locations, making it possible to change each cursor’s appearance simply by switching from one stored image to another.

Two sets of eight registers (XRA0-XRA7 for cursor 1, and XRA8-XRAF for cursor 2) provide the means to configure and position both cursors. In each set of eight registers, two are used to enable, disable, and configure each cursor. Another pair of registers from each set specifies the base address within the frame buffer memory where the cursor data is kept. These registers also provide a way to select one of up to sixteen cursor patterns to be used. The remaining four registers of each set are used to provide the X and Y coordinates to control the current location of each cursor relative to the upper left-hand corner of the display.

Two sets of four alternate color data positions added to the RAMDAC provide places in which the colors for each of the two cursors are specified (positions 0-3 for cursor 2 colors 0-3, and positions 4-7 for cursor 1 colors 0-3). These alternate color data positions are accessed by the same sub-addressing scheme used to access the standard color data positions of the main RAMDAC palette, with the exception that a bit in Pixel Pipeline Configuration Register 0 (XR80) must be set so that the alternate color data positions are accessible in place of the standard color data positions.

Basic Cursor Configuration

Cursor 1 and cursor 2 can each be independently disabled or configured for one of six possible modes using the Cursor 1 Control Register (XRA0) and the Cursor 2 Control Register (XRA8). Detailed descriptions of each of these six modes are provided later in this section.

Horizontal and/or vertical stretching are functions that may be independently enabled or disabled for each cursor using these registers. Similar to the stretching functions used with the main display image, the stretching functions for each of the cursors only apply to flat panel displays. When enabled, the horizontal and vertical stretching functions for each cursor use the same stretching algorithms and parameter settings selected in the registers used to control the horizontal and vertical stretching functions for the main display image. The horizontal and vertical stretching functions for each cursor can be enabled or disabled entirely independently of the horizontal and vertical stretching functions for the main display image.

These same two registers also provide the means to enable or disable blinking for each cursor, and to choose between two possible locations on the screen for the origin of the coordinate system used to specify the cursor location. A bit in each of these registers provides the ability to choose either the upper left-hand corner of the active display area, or the outer-most upper left-hand corner of the display border surrounding the active display area as the exact location of the origin for the coordinate system for each cursor.

Finally, each of these registers allows the vertical extension function to be enabled or disabled for each cursor. The vertical extension function allows the height of the cursor to be specified independently from its width, allowing cursors that are not square in shape to be created. This function is discussed in more detail later in this section.

Base Address for Cursor Data

The Cursor 1 Base Address Low Register (XRA2) and the Cursor 1 Base Address High Register (XRA3) are used to program the base address in the frame buffer at which the cursor data for cursor 1 begins. The Cursor 2 Base Address Low Register (XRAA) and the Cursor 2 Base Address High Register (XRAB) provide this same function for cursor 2. The base address values stored in these registers actually specify an offset relative to the base address at which the frame buffer begins.

The amount of space allocated for cursor data for each cursor is 4KB. More than one cursor pattern may be stored within this space, depending on the cursor size. While the bits in both the high and low base address registers for each of the cursors are combined to provide the base addresses, the upper four bits of each of the low base address registers (XRA2 for cursor 1, and XRAA for cursor 2) are used to select which of the available patterns stored within each space is to be used for each of the cursors. In the 32x32x2bpp AND/XOR pixel plane mode, up to sixteen 256 byte patterns can be stored in the 4KB memory space, and all four of the upper bits of the low base address registers are used to select one of these sixteen possible patterns. In all three modes with a cursor resolution of 64x64 pixels, up to four patterns of 1KB in size can be stored in the 4KB memory space, and the uppermost two of these four bits are used to select one of these four possible patterns (the other two bits should be set to 0). In both modes with a cursor resolution of 128x128 pixels, only up to two patterns of 2KB in size can be stored, and only the uppermost bit of the four bits is used to select between them (the other three bits should be set to 0).

Cursor Vertical Extension

The cursor vertical extension feature allows the vertical size (height) of either cursor in any of the six possible modes to be altered from the height normally dictated by the choice of cursor mode. The cursor mode still determines the width of the cursor. This feature allows the cursor to have a non-square shape.

This feature is enabled via bit 3 of either the Cursor 1 Control Register (XRA0) for cursor 1 or the Cursor 2 Control Register (XRA8) for cursor 2. Once enabled, the height of the given cursor must be specified -- either in the Cursor 1 Vertical Extension Register (XRA1) for cursor 1, or in the Cursor 2 Vertical Extension Register (XRA9) for cursor 2.

Total size of the cursor data for a given cursor can not exceed the 4KB allotted for the cursor data of each cursor. This places a limit on the height of a cursor of given width and color depth. This also has implications concerning how many patterns may be stored in this space for the given cursor, and the mechanics of selecting which of those patterns is to be displayed using the upper four bits of the low base address register for each cursor.

Cursor Colors

The colors for drawing each of the two cursors are specified in two sets of four alternate color data positions added to the RAMDAC (positions 0-3 for cursor 2 colors 0-3, and positions 4-7 for cursor 1 colors 0-3). These alternate color data positions are accessed using the same sub-addressing scheme used to access the standard color data positions of the main RAMDAC palette, but with bit 0 in the Pixel Pipeline Configuration Register 0 (XR80) set so that the alternate color data positions are made accessible in place of the standard positions.

If the use of a border is enabled, color data positions 6 and 7, which provide colors 2 and 3 for cursor 1, will be taken over to specify the border colors for the CRT and flat-panel. This will limit cursor 1 to only colors 0 and 1. This limit on cursor 1 will not impact either of the AND/XOR pixel plane modes, or either of the cursor modes with a cursor resolution of 128x128 pixels because none of these four modes use cursor colors 2 or 3.

Cursor Positioning

Registers XRA4-XRA7 and registers XRAC-XRAF are used to position cursor 1 and cursor 2, respectively, on the display. Two registers from each group provide the high and low bytes for the value specifying the horizontal position, and the other two provide the high and low bytes for the value specifying the vertical position.

A bit in one of the configuration registers (XRA0 for cursor 1 and XRA8 for cursor 2) selects whether the values programmed into these registers are interpreted as being relative to the upper left-hand corner of the active display area or to the outer-most upper left-hand corner of the border surrounding the active display area.

The values provided to these registers are signed 12-bit integers. Since the origin of the coordinate system is generally relative to the upper left corner of the display, a cursor appearing entirely within the active display area will have a positive horizontal position value and a negative vertical position value.

These registers are double-buffered and synchronized to VSYNC to ensure that the cursor never appears to come apart in multiple fragments as it is being moved across the screen. To change a cursor position, all four of its position registers must be written, and they must be written in sequence (that is, in order from XRA4 to XRA7 for cursor 1, and in order from XRAC to XRAF for cursor 2.) The hardware will only update the position with the next VSYNC if the registers are written in sequence.

Cursor Modes

Each cursor can be independently disabled or set to one of six possible modes. This is done by using bits 2-0 in XRA0 for cursor 1 and in XRA8 for cursor 2. The main features which distinguish these modes from each other are the manner in which the cursor data is organized in memory and the meaning of the bits corresponding to each pixel position. The six possible modes are:

- 32x32x2bpp AND/XOR pixel plane mode
- 64x64x2bpp AND/XOR pixel plane mode
- 64x64x2bpp 4-color mode
- 64x64x2bpp 3-color and transparency mode
- 128x128x1bpp 2-color mode
- 128x128x1bpp 1-color and transparency mode

The first two modes are designed to follow the Microsoft Windows™ 2-plane cursor data structure to ease the work of programming the cursor(s) for that particular GUI environment. The other four modes are intended to improve upon the first two modes by providing additional color options or a larger resolution. The following pages discuss the various modes in greater detail.

32x32x2bpp & 64x64x2bpp AND/XOR Pixel Plane Modes

These two modes are designed to follow the Microsoft Windows™ cursor data plane structure, which provides two colors that may be used to draw the cursor, a third color for transparency (which allows the main display image behind the cursor to show through), and a fourth color for inverted transparency (which allows the main display image behind the cursor to show through, but with its color inverted). Each pixel position within the cursor is defined by the combination of two bits of data, each of which is stored in planes referred to as the “AND” plane and the “XOR” plane.

In the 32x32x2bpp AND/XOR pixel plane mode, it is possible to have up to 16 different 256byte patterns stored in a 4KB memory space starting at the base address specified in the low and high base address registers for the given cursor. In 64x64x2bpp AND/XOR pixel plane mode, only up to 4 different 1KB patterns may be stored.

The following tables show how the cursor data is organized in memory for each of these two modes:

**Table D-1: Memory Organization
32x32x2bpp AND/XOR Pixel Plane Mode**

Offset	Plane	Pixels
000h	AND	31-0 on line 0 of pattern 0
004h	AND	31-0 on line 1 of pattern 0
008h	XOR	31-0 on line 0 of pattern 0
00Ch	XOR	31-0 on line 1 of pattern 0
010h	AND	31-0 on line 2 of pattern 0
014h	AND	31-0 on line 3 of pattern 0
...
0F0h	AND	31-0 on line 30 of pattern 0
0F4h	AND	31-0 on line 31 of pattern 0
0F8h	XOR	31-0 on line 30 of pattern 0
0FCh	XOR	31-0 on line 31 of pattern 0
100h	AND	31-0 on line 0 of pattern 1
104h	AND	31-0 on line 1 of pattern 1
...
FF8h	XOR	31-0 of line 30 of pattern 1
FFCh	XOR	31-0 of line 31 of pattern 1

**Table D-2: Memory Organization
64x64x2bpp AND/XOR Pixel Plane Mode**

Offset	Plane	Pixels
000h	AND	31-0 on line 0 of pattern 0
004h	AND	63-32 on line 0 of pattern 0
008h	XOR	31-0 on line 0 of pattern 0
00Ch	XOR	63-32 on line 0 of pattern 0
010h	AND	31-0 on line 1 of pattern 0
014h	AND	63-32 on line 1 of pattern 0
...
3F0h	AND	31-0 on line 63 of pattern 0
3F4h	AND	63-32 on line 63 of pattern 0
3F8h	XOR	31-0 on line 63 of pattern 0
3FCh	XOR	63-32 on line 63 of pattern 0
400h	AND	31-0 on line 0 of pattern 1
404h	AND	63-32 on line 0 of pattern 1
...
FF8h	XOR	31-0 on line 63 of pattern 3
FFCh	XOR	63-32 on line 63 of pattern 3

The meaning of the single bit in a given pixel position in the XOR plane changes depending on the bit in the corresponding position in the AND plane. If the value of the bit for a given pixel position in the AND plane is 0, then part of the cursor will be displayed at that pixel position, and the value of the corresponding bit in the XOR plane selects one of the two available cursor colors to be displayed there. Otherwise, if the value of the bit in the AND plane is 1, then that pixel position of the cursor will become transparent, allowing a pixel of the main display image behind the cursor to show through, and the value of the corresponding bit in the XOR plane chooses whether or not the color of the pixel of the main display image will be inverted. Table D-3 summarizes this.

**Table D-3: Pixel Data
32x32x2bpp and 64x64x2bpp AND/XOR Pixel Plane Modes**

AND Plane Pixel Data	XOR Plane Pixel Data	Color Displayed at the Corresponding Pixel Position
0	0	Cursor color 0
0	1	Cursor color 1
1	0	Transparent. The pixel of the main display image behind cursor shows through
1	1	Transparent, but inverted. The pixel of the main display image behind cursor shows through with inverted color

64x64x2bpp 4-Color Mode

This mode provides four colors for drawing the cursor. There is no provision for transparency in the 64x64 pixel space occupied by the cursor, so unless the image behind the cursor happens to be the same color as one of the four colors used to draw the cursor, the cursor will appear to be a 64 x 64 pixel square. Each pixel position within the cursor is defined by the combination of two bits, each of which is stored in planes referred to as plane 0 and plane 1.

In this mode, it is possible to have up to 4 different 1KB patterns stored in a 4KB memory space starting at the base address specified in the low and high base address registers for the given cursor.

The following tables show how the cursor data is organized in memory and the meaning of the two bits for each pixel position.

**Table D-4: Memory Organization
64x64x2bpp 4-Color Mode**

Offset	Plane	Pixels
000h	0	31-0 on line 0 of pattern 0
004h	0	63-32 on line 0 of pattern 0
008h	1	31-0 on line 0 of pattern 0
00Ch	1	63-32 on line 0 of pattern 0
010h	0	31-0 on line 1 of pattern 0
014h	0	63-32 on line 1 of pattern 0
...
3F0h	0	31-0 on line 63 of pattern 0
3F4h	0	63-32 on line 63 of pattern 0
3F8h	1	31-0 on line 63 of pattern 0
3FCh	1	63-32 on line 63 of pattern 0
400h	0	31-0 on line 0 of pattern 1
404h	0	63-32 on line 0 of pattern 1
...
FF8h	1	31-0 on line 63 of pattern 3
FFCh	1	63-32 on line 63 of pattern 3

**Table D- 5:Pixel Data
64x64x2bpp 4-Color Mode**

Plane 0 Pixel Data	Plane 1 Pixel Data	Color Displayed at the Corresponding Pixel Position
0	0	Cursor color 0
0	1	Cursor color 1
1	0	Cursor color 2
1	1	Cursor color 3

64x64x2bpp 3-Color and Transparency Mode

This mode provides three colors for drawing the cursor and a fourth color for transparency (which allows the main display image behind the cursor to show through). Each pixel position in the cursor is defined by the combination of two bits, stored in planes referred to as plane 0 and plane 1.

In this mode, it is possible to have up to 4 1KB different patterns stored in a 4KB memory space starting at the base address specified in the low and high base address registers for the given cursor.

The following tables show how the cursor data is organized in memory and the meaning of the two bits for each pixel position.

**Table D-6: Memory Organization
64x64x2bpp 3-Color & Transparency Mode**

Offset	Plane	Pixels
000h	0	31-0 on line 0 of pattern 0
004h	0	63-32 on line 0 of pattern 0
008h	1	31-0 on line 0 of pattern 0
00Ch	1	63-32 on line 0 of pattern 0
010h	0	31-0 on line 1 of pattern 0
014h	0	63-32 on line 1 of pattern 0
...
3F0h	0	31-0 on line 63 of pattern 0
3F4h	0	63-32 on line 63 of pattern 0
3F8h	1	31-0 on line 63 of pattern 0
3FCh	1	63-32 on line 63 of pattern 0
400h	0	31-0 on line 0 of pattern 1
404h	0	63-32 on line 0 of pattern 1
...
FF8h	1	31-0 on line 63 of pattern 3
FFCh	1	63-32 on line 63 of pattern 3

**Table D-7: Pixel Data
64x64x2bpp 3-Color & Transparency Mode**

Plane 0 Pixel Data	Plane 1 Pixel Data	Color Displayed at the Corresponding Pixel Position
0	0	Cursor color 0
0	1	Cursor color 1
1	0	Transparent Pixel of the image behind the cursor shows through
1	1	Cursor color 3

128x128x1bpp 2-Color Mode

This mode provides two colors for drawing the cursor. There is no provision for transparency in the 128x128 pixel space occupied by the cursor, so unless the image behind the cursor happens to be the same color as one of the two colors used to draw the cursor, the cursor will appear as a 128x128 pixel square.

In this mode, it is possible to have only up to 2 different 2KB patterns stored in a 4KB memory space starting at the base address specified in the low and high base address registers for the given cursor.

The following tables show how the cursor data is organized in memory and the meaning of the bit for each position.

**Table D-8: Memory Organization
128x128x1bpp 2-Color Mode**

Offset	Pixels
000h	31-0 on line 0 of pattern 0
004h	63-32 on line 0 of pattern 0
008h	95-64 on line 0 of pattern 0
00Ch	127-96 on line 0 of pattern 0
010h	31-0 on line 1 of pattern 0
014h	63-32 on line 1 of pattern 0
...	...
7F0h	31-0 on line 127 of pattern 0
7F4h	63-32 on line 127 of pattern 0
7F8h	95-64 on line 127 of pattern 0
7FCh	127-96 on line 127 of pattern 0
800h	31-0 on line 0 of pattern 1
804h	63-32 on line 0 of pattern 1
...	...
FF8h	95-64 on line 127 of pattern 1
FFCh	127-96 on line 127 of pattern 1

**Table D-9: Pixel Data
128x128x1bpp 2-Color Mode**

Pixel Data Bit	Color Displayed at the Corresponding Pixel Position
0	Cursor color 2
1	Cursor color 3

128x128x1bpp 1-Color and Transparency Mode

This mode provides one color for drawing the cursor and a second color for transparency (which allows the image behind the cursor to show through).

In this mode, it is possible to have only up to 2 different 2KB patterns stored in a 4KB memory space starting at the base address specified in the low and high base address registers for the given cursor.

The following tables show how the cursor data is organized in memory and the meaning of the bit for each position.

**Table D-10: Memory Organization
128x128x1bpp 1-Color & Transparency Mode**

Offset	Pixels
000h	31-0 on line 0 of pattern 0
004h	63-32 on line 0 of pattern 0
008h	95-64 on line 0 of pattern 0
00Ch	127-96 on line 0 of pattern 0
010h	31-0 on line 1 of pattern 0
014h	63-32 on line 1 of pattern 0
...	...
7F0h	31-0 on line 127 of pattern 0
7F4h	63-32 on line 127 of pattern 0
7F8h	95-64 on line 127 of pattern 0
7FCh	127-96 on line 127 of pattern 0
800h	31-0 on line 0 of pattern 1
804h	63-32 on line 0 of pattern 1
...	...
FF8h	95-64 on line 127 of pattern 1
FFCh	127-96 on line 127 of pattern 1

**Table D-11: Pixel Bit Definitions
128x128x1bpp 1-Color & Transparency Mode**

Pixel Data Bit	Color Displayed at the Corresponding Pixel Position
0	Transparent. Pixel of the image behind cursor shows through
1	Cursor color 2

Appendix E

BitBLT Operation

Introduction

The graphics controller provides a hardware-based BitBLT engine to offload the work of moving blocks of graphics data from the host CPU. Although the BitBLT engine is often used simply to copy a block of graphics data from the source to the destination, it also has the ability to perform more complex functions. The BitBLT engine is capable of receiving three different blocks of graphics data as input as shown in Figure E-1. The source data may exist either in the frame buffer or it may be provided by the host CPU from some other source such as system memory. The pattern data always represents an 8x8 block of pixels that must be located in the frame buffer, usually within the off-screen portion. The input destination data is the data already residing at the destination in the frame buffer prior to a BitBLT operation being performed. The output destination data is the data written to the destination as a result of a BitBLT operation.

The BitBLT engine may be configured to use various combinations of the source, pattern, and input destination data as operands, in both bit-wise logical operations to generate the output destination data. It is intended that the BitBLT engine will perform these bit-wise and per-pixel operations on color graphics data that is at a color depth that matches the rest of the graphics system. However, if either the source or pattern data is monochrome, the BitBLT engine has the ability to put either block of graphics data through a process called “color expansion” which converts the monochrome graphics data to color. Since the destination is often a location in the on-screen portion of the frame buffer, it is assumed that any data already residing at the destination will be of the appropriate color depth.

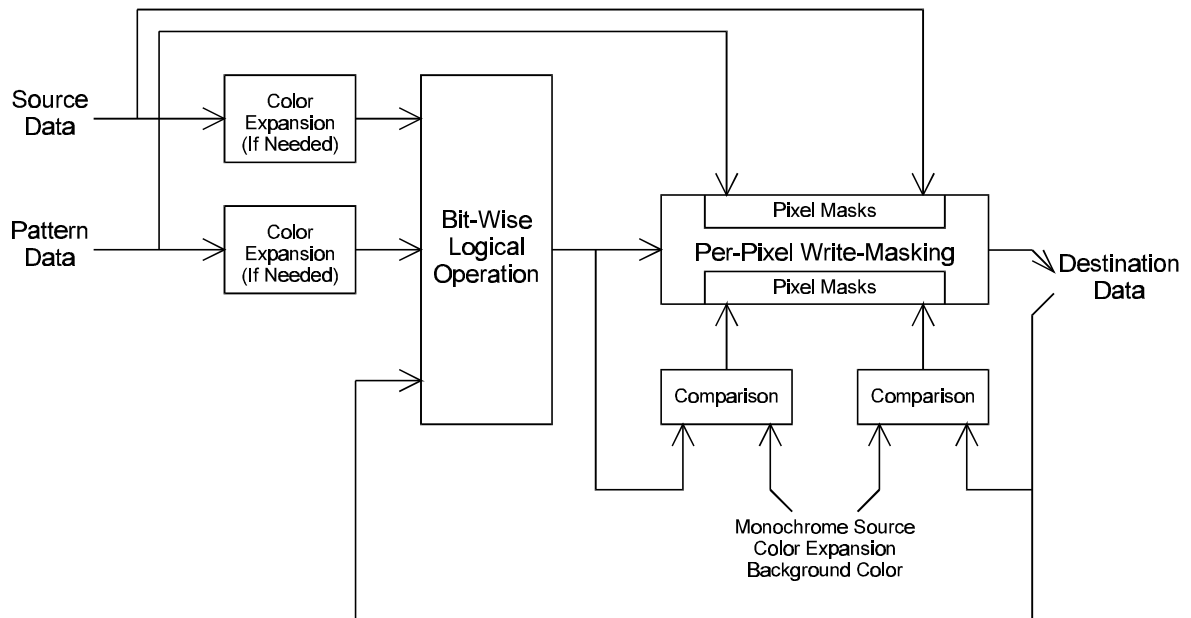

Figure E-1: Block Diagram and Data Paths of the BitBLT Engine

Color Depth Configuration and Color Expansion

The graphics system can be configured for color depths of 1, 2, 4, 8, 16, 24, and 32 bits per pixel, while the BitBLT engine is intended to work only with graphics data having a color depth of only 8, 16, or 24 bits per pixel. It is assumed that the BitBLT engine will not be used when the graphics system has been configured for a color depth that the BitBLT engine was not designed to support. In theory, it is possible to configure the BitBLT engine and graphics system for different color depths, but this is not recommended.

The configuration of the BitBLT engine for a given color depth dictates the number of bytes of graphics data that the BitBLT engine will read and write for each pixel while performing a BitBLT operation. It is assumed that any input destination data from the frame buffer will already be at the color depth to which the BitBLT engine is configured. Similarly, it is assumed that any source or pattern data used as an input will have this same color depth, unless one or both is monochrome. If either the source or pattern data is monochrome, the BitBLT engine will perform a process called "color expansion" to convert such monochrome data to color at the color depth to which the BitBLT engine has been set.

During "color expansion" the individual bits of monochrome source or pattern data that correspond to individual pixels are converted to 8, 16, or 24 bits per pixel (i.e., 1, 2, or 3 bytes per pixel -- whichever is appropriate for the color depth to which the BitBLT engine has been set). If a given bit of monochrome source or pattern data carries a value of 1, then the byte(s) of color data resulting from the conversion process will be set to the value of a specified foreground color. If a given bit of monochrome source or pattern data carries a value of 0, the resulting byte(s) will be set to the value of a specified background color.

The BitBLT engine is configured for a color depth of 8, 16, or 24 bits per pixel through either bits 5 and 4 of XR20, or bits 25 and 24 of BR04, depending upon the setting of bit 23 of BR04. Whether the source and pattern data are color or monochrome must be specified using bits 12 and 18, respectively, of BR04. The foreground and background colors for the color expansion of both monochrome source and pattern data may be specified using BR02 and BR01, respectively. Alternatively, if bit 27 of BR03 is set to 1, the foreground and background colors used in the color expansion of monochrome source data may be independently specified using BR0A and BR09, respectively.

Graphics Data Size Limitations

The BitBLT engine is capable of transferring very large quantities of graphics data. Any graphics data read from and written to the destination is permitted to represent a number of pixels that occupies up to 8191 scanlines and up to 8191 bytes per scanline at the destination. Therefore, the maximum number of pixels that may be represented per scanline's worth of graphics data depends on the color depth.

Any source data must represent both the same number of pixels per scanline and the same number of scanlines as both the input and output destination data. Despite these constraints, if the source data is received from the host CPU via the BitBLT dataport, that source data may be received as part of a much larger block of data sent by the host CPU. The BitBLT engine may be programmed to skip over various quantities of bytes within such a block in order to reach the bytes containing valid source data.

The actual number of scanlines and bytes per scan line required to accommodate both input and output destination data are set in BR08. These two values are essential in the programming of the BitBLT engine, because these values are used by the BitBLT engine to determine when a given BitBLT operation has been completed. It is important to note that writing a non-zero value to BR08 is the trigger that causes the BitBLT engine to begin a BitBLT operation. Therefore, all other registers must be set as desired for a given BitBLT operation before BR08.

Bit-Wise Operations

The BitBLT engine can perform any one of 256 possible bit-wise operations using various combinations of the source, pattern, and input destination data as inputs. These 256 possible bit-wise operations are designed to be compatible with the manner in which raster operations are specified in the BitBLT parameter block used in the Microsoft® Windows™ environment, without translation.

The choice of bit-wise operation selects which of the three inputs will be used, as well as the particular logical operation to be performed on corresponding bits from each of the selected inputs. The BitBLT engine will automatically forego reading any form of graphics data that has not been specified as an input by the choice of bit-wise operation. An 8-bit code written to BR04 chooses the bit-wise operation. The tables on the following pages list the available bit-wise operations and their corresponding 8-bit codes.

Table E-1: Bit-Wise Operations and 8-bit Codes (00 - 5F)

Code	Value Written to Bits at Destination	Code	Value Written to Bits at Destination
00	writes all 0's	30	P and (notS)
01	not(D or (P or S)))	31	not(S or (D and (notP)))
02	D and (not(P or S))	32	S xor (D or (P or S))
03	not(P or S)	33	notS
04	S and (not(D or P))	34	S xor (P or (D and S))
05	not(D or P)	35	S xor (P or (not(D xor S)))
06	not(P or (not(D xor S)))	36	S xor (D or P)
07	not(P or (D and S))	37	not(S and (D or P))
08	S and (D and (notP))	38	P xor (S and (D or P))
09	not(P or (D xor S))	39	S xor (P or (notD))
0A	D and (notP)	3A	S xor (P or (D xor S))
0B	not(P or (S and (notD)))	3B	not(S and (P or (notD)))
0C	S and (notP)	3C	P xor S
0D	not(P or (D and (notS)))	3D	S xor (P or (not(D or S)))
0E	not(P or (not(D or S)))	3E	S xor (P or (D and (notS)))
0F	notP	3F	not(P and S)
10	P and (not(D or S))	40	P and (S and (notD))
11	not(D or S)	41	not(D or (P xor S))
12	not(S or (not(D xor P)))	42	(S xor D) and (P xor D)
13	not(S or (D and P))	43	not(S xor (P and (not(D and S)))
14	not(D or (not(P xor S)))	44	S and (notD)
15	not(D or (P and S))	45	not(D or (P and (notS)))
16	P xor (S xor (D and (not(P and S)))	46	D xor (S or (P and D))
17	not(S xor ((S xor P) and (D xor S)))	47	not(P xor (S and (D xor P)))
18	(S xor P) and (P xor D)	48	S and (D xor P)
19	not(S xor (D and (not(P and S)))	49	not(P xor (D xor (S or (P and D)))
1A	P xor (D or (S and P))	4A	D xor (P and (S or D))
1B	not(S xor (D and (P xor S)))	4B	P xor (D or (notS))
1C	P xor (S or (D and P))	4C	S and (not(D and P))
1D	not(D xor (S and (P xor D)))	4D	not(S xor ((S xor P) or (D xor S)))
1E	P xor (D or S)	4E	P xor (D or (S xor P))
1F	not(P and (D or S))	4F	not(P and (D or (notS)))
20	D and (P and (notS))	50	P and (notD)
21	not(S or (D xor P))	51	not(D or (S and (notP)))
22	D and (notS)	52	D xor (P or (S and D))
23	not(S or (P and (notD)))	53	not(S xor (P and (D xor S)))
24	(S xor P) and (D xor S)	54	not(D or (not(P or S)))
25	not(P xor (D and (not(S and P)))	55	notD
26	S xor (D or (P and S))	56	D xor (P or S)
27	S xor (D or (not(P xor S)))	57	not(D and (P or S))
28	D and (P xor S)	58	P xor (D and (S or P))
29	not(P xor (S xor (D or (P and S)))	59	D xor (P or (notS))
2A	D and (not(P and S))	5A	D xor P
2B	not(S xor ((S xor P) and (P xor D)))	5B	D xor (P or (not(S or D)))
2C	S xor (P and (D or S))	5C	D xor (P or (S xor D))
2D	P xor (S or (notD))	5D	not(D and (P or (notS)))
2E	P xor (S or (D xor P))	5E	D xor (P or (S and (notD)))
2F	not(P and (S or (notD)))	5F	not(D and P)

Notes: S = Source Data

P = Pattern Data

D = Input Destination Data (data at destination prior to BitBLT operation)

Table E-2: Bit-Wise Operations and 8-bit Codes (60 - BF)

Code	Value Written to Bits at Destination	Code	Value Written to Bits at Destination
60	$P \text{ and } (D \text{ xor } S)$	90	$P \text{ and } (\text{not}(D \text{ xor } S))$
61	$\text{not}(D \text{ xor } (S \text{ xor } (P \text{ or } (D \text{ and } S))))$	91	$\text{not}(S \text{ xor } (D \text{ and } (P \text{ or } (\text{not}S))))$
62	$D \text{ xor } (S \text{ and } (P \text{ or } D))$	92	$D \text{ xor } (P \text{ xor } (S \text{ and } (D \text{ or } P)))$
63	$S \text{ xor } (D \text{ or } (\text{not}P))$	93	$\text{not}(S \text{ xor } (P \text{ and } D))$
64	$S \text{ xor } (D \text{ and } (P \text{ or } S))$	94	$P \text{ xor } (S \text{ xor } (D \text{ and } (P \text{ or } S)))$
65	$D \text{ xor } (S \text{ or } (\text{not}P))$	95	$\text{not}(D \text{ xor } (P \text{ and } S))$
66	$D \text{ xor } S$	96	$D \text{ xor } (P \text{ xor } S)$
67	$S \text{ xor } (D \text{ or } (\text{not}(P \text{ or } S)))$	97	$P \text{ xor } (S \text{ xor } (D \text{ or } (\text{not}(P \text{ or } S))))$
68	$\text{not}(D \text{ xor } (S \text{ xor } (P \text{ or } (\text{not}(D \text{ or } S)))))$	98	$\text{not}(S \text{ xor } (D \text{ or } (\text{not}(P \text{ or } S))))$
69	$\text{not}(P \text{ xor } (D \text{ xor } S))$	99	$\text{not}(D \text{ xor } S)$
6A	$D \text{ xor } (P \text{ and } S)$	9A	$D \text{ xor } (P \text{ and } (\text{not}S))$
6B	$\text{not}(P \text{ xor } (S \text{ xor } (D \text{ and } (P \text{ or } S))))$	9B	$\text{not}(S \text{ xor } (D \text{ and } (P \text{ or } S)))$
6C	$S \text{ xor } (D \text{ and } P)$	9C	$S \text{ xor } (P \text{ and } (\text{not}D))$
6D	$\text{not}(P \text{ xor } (D \text{ xor } (S \text{ and } (P \text{ or } D))))$	9D	$\text{not}(D \text{ xor } (S \text{ and } (P \text{ or } D)))$
6E	$S \text{ xor } (D \text{ and } (P \text{ or } (\text{not}S)))$	9E	$D \text{ xor } (S \text{ xor } (P \text{ or } (D \text{ and } S)))$
6F	$\text{not}(P \text{ and } (\text{not}(D \text{ xor } S)))$	9F	$\text{not}(P \text{ and } (D \text{ xor } S))$
70	$P \text{ and } (\text{not}(D \text{ and } S))$	A0	$D \text{ and } P$
71	$\text{not}(S \text{ xor } ((S \text{ xor } D) \text{ and } (P \text{ xor } D)))$	A1	$\text{not}(P \text{ xor } (D \text{ or } (S \text{ and } (\text{not}P))))$
72	$S \text{ xor } (D \text{ or } (P \text{ xor } S))$	A2	$D \text{ and } (P \text{ or } (\text{not}S))$
73	$\text{not}(S \text{ and } (D \text{ or } (\text{not}P)))$	A3	$\text{not}(D \text{ xor } (P \text{ or } (S \text{ xor } D)))$
74	$D \text{ xor } (S \text{ or } (P \text{ xor } D))$	A4	$\text{not}(P \text{ xor } (D \text{ or } (\text{not}(S \text{ or } P))))$
75	$\text{not}(D \text{ and } (S \text{ or } (\text{not}P)))$	A5	$\text{not}(P \text{ xor } D)$
76	$S \text{ xor } (D \text{ or } (P \text{ and } (\text{not}S)))$	A6	$D \text{ xor } (S \text{ and } (\text{not}P))$
77	$\text{not}(D \text{ and } S)$	A7	$\text{not}(P \text{ xor } (D \text{ and } (S \text{ or } P)))$
78	$P \text{ xor } (D \text{ and } S)$	A8	$D \text{ and } (P \text{ or } S)$
79	$\text{not}(D \text{ xor } (S \text{ xor } (P \text{ and } (D \text{ or } S))))$	A9	$\text{not}(D \text{ xor } (P \text{ or } S))$
7A	$D \text{ xor } (P \text{ and } (S \text{ or } (\text{not}D)))$	AA	D
7B	$\text{not}(S \text{ and } (\text{not}(D \text{ xor } P)))$	AB	$D \text{ or } (\text{not}(P \text{ or } S))$
7C	$S \text{ xor } (P \text{ and } (D \text{ or } (\text{not}S)))$	AC	$S \text{ xor } (P \text{ and } (D \text{ xor } S))$
7D	$\text{not}(D \text{ and } (\text{not}(P \text{ xor } S)))$	AD	$\text{not}(D \text{ xor } (P \text{ or } (S \text{ and } D)))$
7E	$(S \text{ xor } P) \text{ or } (D \text{ xor } S)$	AE	$D \text{ or } (S \text{ and } (\text{not}P))$
7F	$\text{not}(D \text{ and } (P \text{ and } S))$	AF	$D \text{ or } (\text{not}P)$
80	$D \text{ and } (P \text{ and } S)$	B0	$P \text{ and } (D \text{ or } (\text{not}S))$
81	$\text{not}((S \text{ xor } P) \text{ or } (D \text{ xor } S))$	B1	$\text{not}(P \text{ xor } (D \text{ or } (S \text{ xor } P)))$
82	$D \text{ and } (\text{not}(P \text{ xor } S))$	B2	$S \text{ xor } ((S \text{ xor } P) \text{ or } (D \text{ xor } S))$
83	$\text{not}(S \text{ xor } (P \text{ and } (D \text{ or } (\text{not}S))))$	B3	$\text{not}(S \text{ and } (\text{not}(D \text{ and } P)))$
84	$S \text{ and } (\text{not}(D \text{ xor } P))$	B4	$P \text{ xor } (S \text{ and } (\text{not}D))$
85	$\text{not}(P \text{ xor } (D \text{ and } (S \text{ or } (\text{not}P))))$	B5	$\text{not}(D \text{ xor } (P \text{ and } (S \text{ or } D)))$
86	$D \text{ xor } (S \text{ xor } (P \text{ and } (D \text{ or } S)))$	B6	$D \text{ xor } (P \text{ xor } (S \text{ or } (D \text{ and } P)))$
87	$\text{not}(P \text{ xor } (D \text{ and } S))$	B7	$\text{not}(S \text{ and } (D \text{ xor } P))$
88	$D \text{ and } S$	B8	$P \text{ xor } (S \text{ and } (D \text{ xor } P))$
89	$\text{not}(S \text{ xor } (D \text{ or } (P \text{ and } (\text{not}S))))$	B9	$\text{not}(D \text{ xor } (S \text{ or } (P \text{ and } D)))$
8A	$D \text{ and } (S \text{ or } (\text{not}P))$	BA	$D \text{ or } (P \text{ and } (\text{not}S))$
8B	$\text{not}(D \text{ xor } (S \text{ or } (P \text{ xor } D)))$	BB	$D \text{ or } (\text{not}S)$
8C	$S \text{ and } (D \text{ or } (\text{not}P))$	BC	$S \text{ xor } (P \text{ and } (\text{not}(D \text{ and } S)))$
8D	$\text{not}(S \text{ xor } (D \text{ or } (P \text{ xor } S)))$	BD	$\text{not}((S \text{ xor } D) \text{ and } (P \text{ xor } D))$
8E	$S \text{ xor } ((S \text{ xor } D) \text{ and } (P \text{ xor } D))$	BE	$D \text{ or } (P \text{ xor } S)$
8F	$\text{not}(P \text{ and } (\text{not}(D \text{ and } S)))$	BF	$D \text{ or } (\text{not}(P \text{ and } S))$

Notes: S = Source Data

P = Pattern Data

D = Input Destination Data (data at destination prior to BitBLT operation)

Table E-3: Bit-Wise Operations and 8-bit Codes (C0 - FF)

Code	Value Written to Bits at Destination	Code	Value Written to Bits at Destination
C0	P and S	E0	P and (D or S)
C1	not(S xor (P or (D and (notS)))))	E1	not(P xor (D or S))
C2	not(S xor (P or (not(D or S)))))	E2	D xor (S and (P xor D))
C3	not(P xor S)	E3	not(P xor (S or (D and P)))
C4	S and (P or (notD))	E4	S xor (D and (P xor S))
C5	not(S xor (P or (D xor S)))	E5	not(P xor (D or (S and P)))
C6	S xor (D and (notP))	E6	S xor (D and (not(P and S)))
C7	not(P xor (S and (D or P)))	E7	not((S xor P) and (P xor D))
C8	S and (D or P)	E8	S xor ((S xor P) and (D xor S))
C9	not(S xor (P or D))	E9	not(D xor (S xor (P and (not(D and S))))))
CA	D xor (P and (S xor D))	EA	D or (P and S)
CB	not(S xor (P or (D and S)))	EB	D or (not(P xor S))
CC	S	EC	S or (D and P)
CD	S or (not(D or P))	ED	S or (not(D xor P))
CE	S or (D and (notP))	EE	D or S
CF	S or (notP)	EF	S or (D or (notP))
D0	P and (S or (notD))	F0	P
D1	not(P xor (S or (D xor P)))	F1	P or (not(D or S))
D2	P xor (D and (notS))	F2	P or (D and (notS))
D3	not(S xor (P and (D or S)))	F3	P or (notS)
D4	S xor ((S xor P) and (P xor D))	F4	P or (S and (notD))
D5	not(D and (not(P and S)))	F5	P or (notD)
D6	P xor (S xor (D or (P and S)))	F6	P or (D xor S)
D7	not(D and (P xor S))	F7	P or (not(D and S))
D8	P xor (D and (S xor P))	F8	P or (D and S)
D9	not(S xor (D or (P and S)))	F9	P or (not(D xor S))
DA	D xor (P and (not(S and D)))	FA	D or P
DB	not((S xor P) and (D xor S))	FB	D or (P or (notS))
DC	S or (P and (notD))	FC	P or S
DD	S or (notD)	FD	P or (S or (notD))
DE	S or (D xor P)	FE	D or (P or S)
DF	S or (not(D and P))	FF	writes all 1's

Notes: S = Source Data

P = Pattern Data

D = Input Destination Data (data at destination prior to BitBLT operation)

Per-Pixel Write Masking

The BitBLT engine is able to perform per-pixel write-masking with various data sources used as pixel masks to constrain which pixels at the destination will actually be written to by the BitBLT engine. As shown in the figure below, either monochrome source or monochrome pattern data may be used as a pixel mask, but not color source or color pattern. Another available pixel mask called “color transparency” is derived by comparing a particular color to either the color already specified for a given pixel at the destination or the color that results from the bit-wise operation performed for a given pixel.

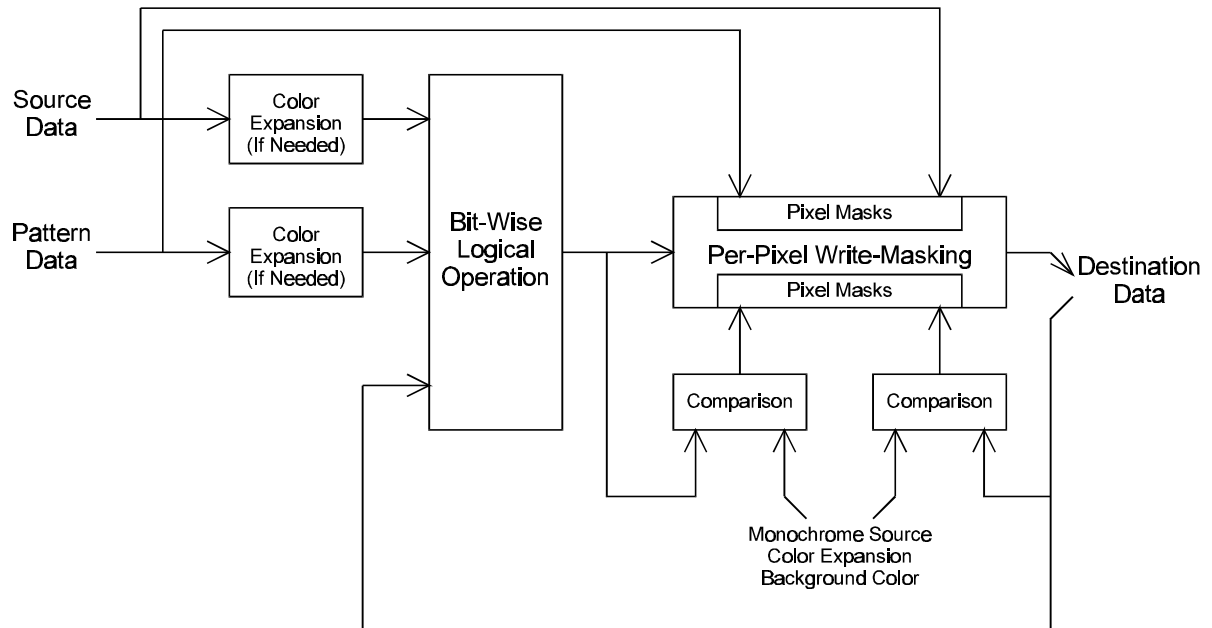

Figure E-2: Block Diagram and Data Paths of the BitBLT Engine

Bits 13 and 17 of BR04 are used to select either the monochrome source or the monochrome pattern data as a pixel mask. When this feature is used, the bits in either the monochrome source or the monochrome pattern data that carry a value of 0 cause the bytes of the corresponding pixel at the destination to not be written to by the BitBLT engine, thereby preserving whatever data already residing within those bytes. This feature can be used in writing characters to the display in a way that preserves the pre-existing backgrounds behind those characters.

Bits 14 through 16 of BR04 are used to select and enable 1 of 4 forms of per-pixel write-masking, each using a different color comparison as a mask. Bit 14 is used to enable this function. Bit 15 chooses between two different comparisons of color values. Depending on the setting of bit 15, a comparison is made between a key color (carried by either BR01 or BR09) and either the color already specified in the bytes for each of the pixels at the destination or the color resulting from the bit-wise operation being performed for each pixel. Bit 16 chooses whether the overwriting of the bytes at the destination will occur when the two compared values are found to be equal or when they are found not to be equal.

When the Source and Destination Locations Overlap

When the source and destination locations are both within the frame buffer, it is possible to have BitBLT operations in which these locations overlap. This frequently occurs in BitBLT operations where a user is shifting the position of a graphical item on the display by only a few pixels. In these situations, the BitBLT engine must be programmed so that output destination data is not written to the part of the destination that overlaps the source before the source data in the area of overlap has been read. Otherwise, the source data will become corrupted as shown in the figure below.

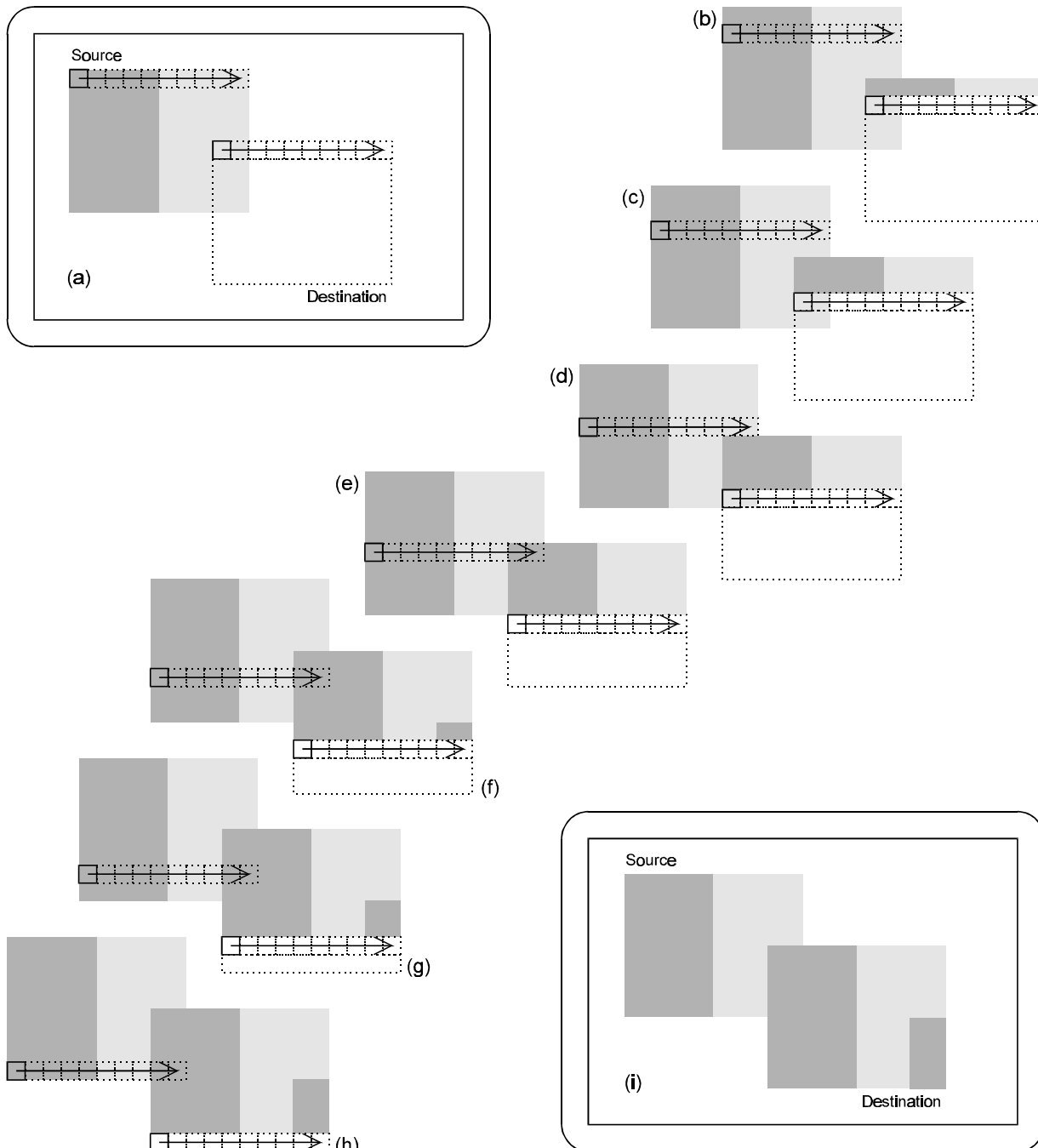

Figure E-3: Source Corruption in BitBLT with Overlapping Source and Destination Locations

The BitBLT engine reads from the source and writes to the destination starting with the left-most pixel in the top-most line of both, as shown in step (a). As shown in step (b), corruption of the source data has already started with the copying of the top-most line in step (a) — part of the source that originally contained lighter-colored pixels has now been overwritten with darker-colored pixels. More source data corruption occurs as steps (b) through (d) are performed. At step (e), another line of the source data is read, but the two right-most pixels of this line are in the region where the source and destination locations overlap, and where the source has already been overwritten as a result of the copying of the top-most line in step (a). Starting in step (f), darker-colored pixels can be seen in the destination where lighter-colored pixels should be. This errant effect occurs repeatedly throughout the remaining steps in this BitBLT operation. As more lines are copied from the source to the destination, it becomes clear that the end result is not as originally intended.

The BitBLT engine can be programmed to alter the order in which source data is read and destination data is written when necessary to avoid the kind of source data corruption problem illustrated earlier. Bits 8 and 9 of BR04 provide the ability to change the point at which the BitBLT engine begins reading and writing data from the upper left-hand corner (the usual starting point) to one of the other three corners. In other words, through the use of these two bits, the BitBLT engine may be set to read data from the source and write it to the destination starting at any of the four corners of the panel. The following figure shows how this feature can be used to perform the same BitBLT operation illustrated earlier, but without corrupting the source data.

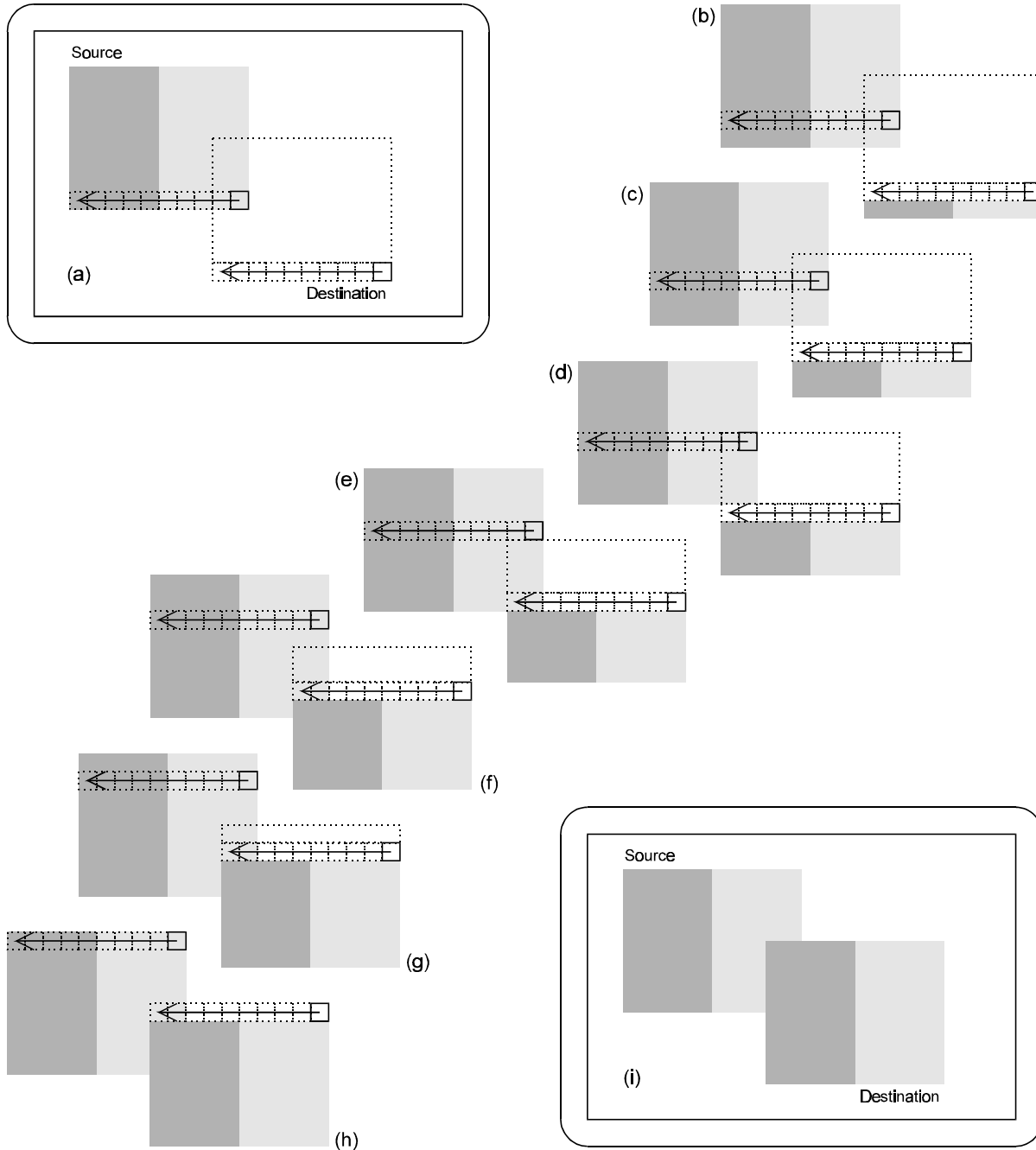

Figure E-4: Correctly Performed BitBLT with Overlapping Source and Destination Locations

The BitBLT engine reads the source data and writes the destination data starting with the right-most pixel of the bottom-most line. By doing this, no pixel existing where the source and destination locations overlap will ever be written to before it is read from by the BitBLT engine. By the time the BitBLT operation has reached step (e) where two pixels existing where the source and destination locations overlap are about to be overwritten, the source data for those two pixels has already been read.

The figure below shows the recommended starting points to be used in each of the 8 possible ways in which the source and destination could overlap. In general, the starting point should be within the area in which the overlap occurs.

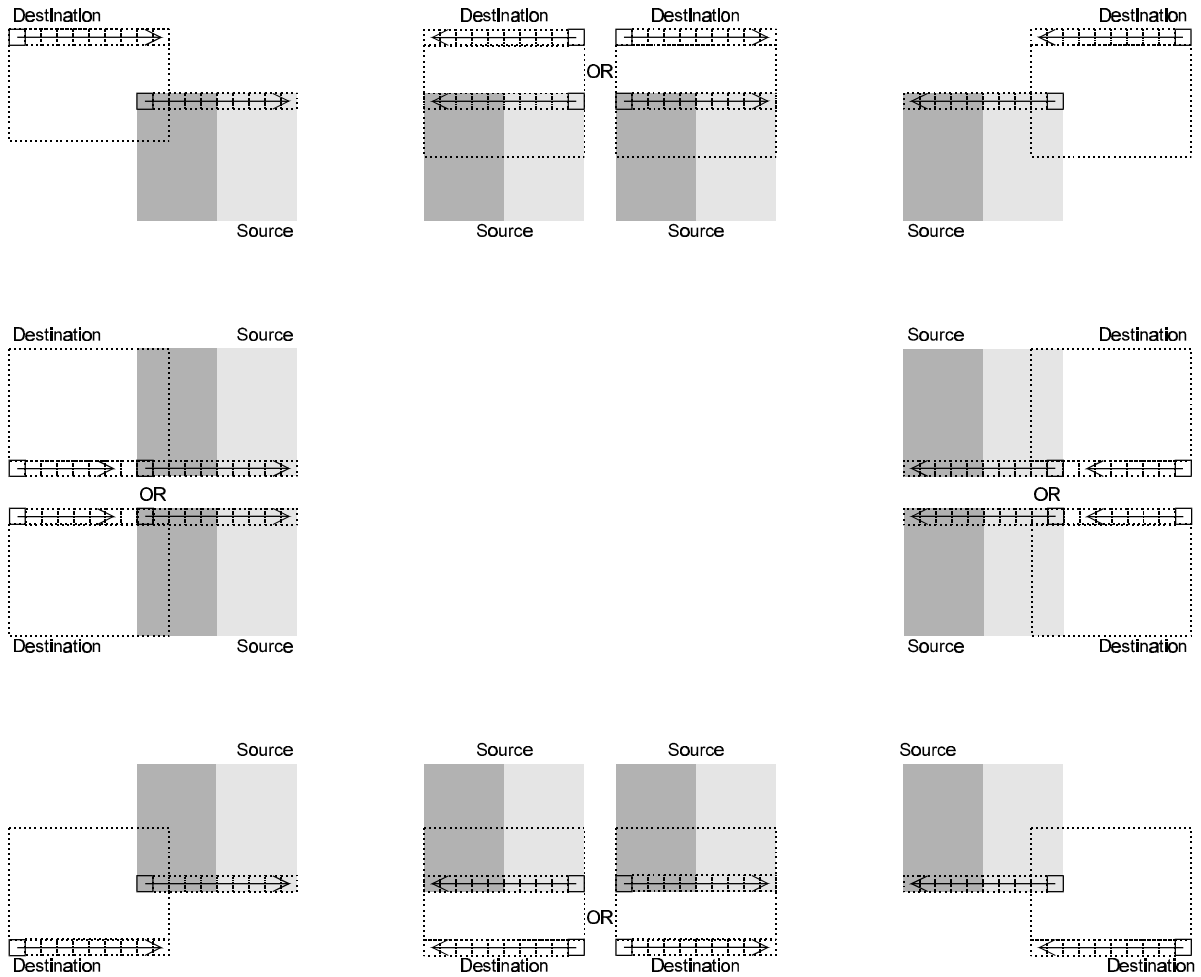

Figure E-5: Suggested Starting Points for Possible Source and Destination Overlap Situations

Contiguous vs. Discontiguous Graphics Data

Graphics data stored in memory, particularly in the frame buffer of a graphics system, has organizational characteristics that often distinguish it from other varieties of data. The main distinctive feature is the tendency for graphics data to be organized in multiple sub-blocks of bytes, instead of a single contiguous block of bytes.

Figure E-6 shows an example of contiguous graphics data — a horizontal line made up of six adjacent pixels within a single scanline on a display with a resolution of 640x480. If it is presumed that the graphics system has been set to 8 bits per pixel, and that the first byte of frame buffer memory at offset 0h corresponds to the upper left-most pixel of this display, then the six pixels that make this horizontal line starting at coordinates (256, 256) would occupy six bytes starting at frame buffer offset 28100h, and ending at offset 28105h.

In this case, this horizontal line exists entirely within one scanline on the display, and so the graphics data for all six of these pixels exists within a single contiguous block comprised of these six bytes. In this simple case, the starting offset and the number of bytes are the only pieces of information that a BitBLT engine would require to read this block of data.

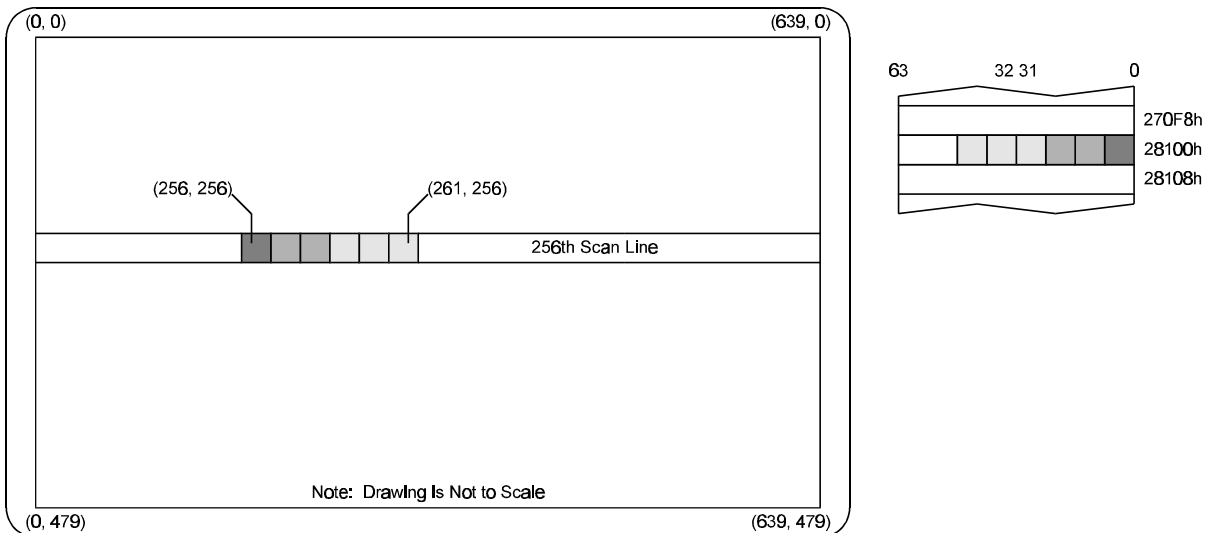

Figure E-6: On-Screen Single 6-Pixel Line in the Frame Buffer

The simplicity of the preceding example of a single horizontal line contrasts sharply to the example of discontiguous graphics data depicted in Figure E-7. The simple six-pixel line of Figure E-6 is now accompanied by three more six-pixel lines placed on subsequent scan lines, resulting in the 6x4 block of pixels shown.

Since there are other pixels on each of the scan lines on which this 6x4 block exists that are not part of this 6x4 block, what appears to be a single 6x4 block of pixels on the display must be represented by a discontiguous block of graphics data made up of 4 separate sub-blocks of six bytes apiece in the frame buffer at addresses 28100h, 28380h, 28600h, and 28880h. This situation makes the task of reading what appears to be a simple 6x4 block of pixels more complex.

Two characteristics of this 6x4 block of pixels help simplify the task of specifying the locations of all 24 bytes of this discontiguous block of graphics data. First, all four of the sub-blocks are of the same length. Second, the four sub-blocks are separated from each other at equal intervals.

The BitBLT engine was designed to make use of these characteristics of graphics data to simplify the programming required to handle discontiguous blocks of graphics data. For such a situation, the BitBLT engine requires only four pieces of information: the starting address of the first sub-block, the length of a sub-block, the offset (in bytes) of the starting address of each subsequent sub-block, and the quantity of sub-blocks.

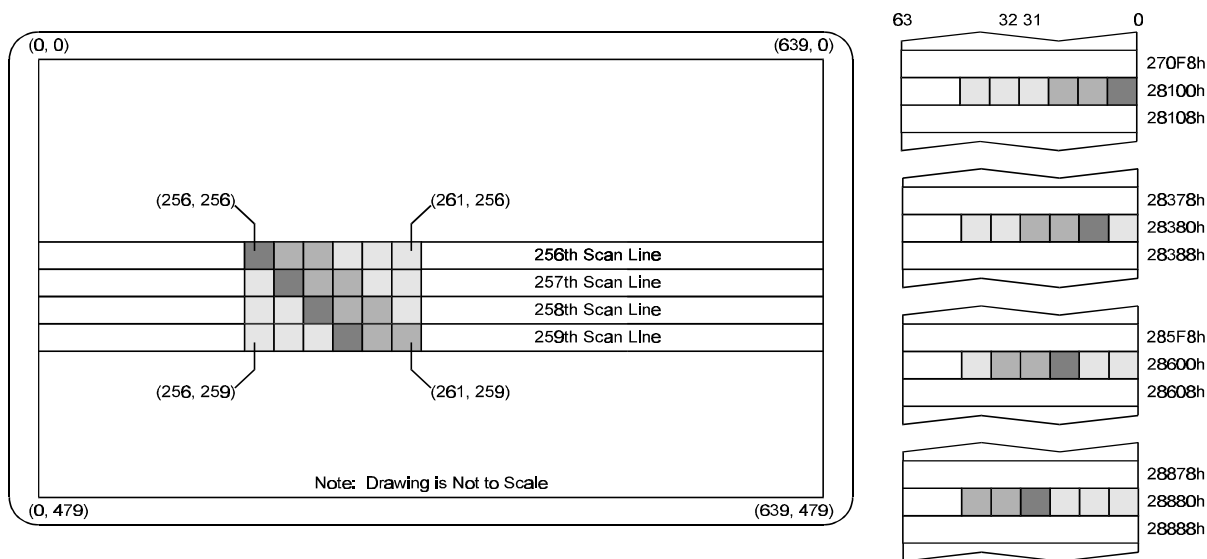

Figure E-7: On-Screen 6x4 Array of Pixels in the Frame Buffer

Source Data

The source data may either exist in the frame buffer where the BitBLT engine may read it directly, or it may be provided to the BitBLT engine by the host CPU. The block of source graphics data may be either contiguous or discontinuous, and may be either in color (with a color depth that matches that to which the BitBLT engine has been set) or monochrome.

Bit 10 of the BitBLT Control Register (BR04) specifies whether the source data exists in the frame buffer or is provided by the CPU. Having the source data in the frame buffer will result in increased performance since the BitBLT engine will be able to access it directly without involving the host CPU.

If the source data resides within the frame buffer, then the Source Address Register (BR06) is used to specify the address of the source data as an offset from the beginning of the frame buffer at which the block of source data begins. However, if the host CPU provides the source data, then this register takes on a different function and the three least-significant bits of the Source Address Register (BR06) can be used to specify a number of bytes that must be skipped in the first quadword received from the host CPU to reach the first byte of valid source data.

In cases where the host CPU provides the source data, it does so by writing the source data to the BitBLT data port, a 64KB memory space on the host bus. There is no actual memory allocated to this memory space, so any data that is written to this location cannot be read back. This memory space is simply a range of memory addresses that the BitBLT engine's address decoder watches for the occurrence of any memory writes. The BitBLT engine loads all data written to any memory address within this memory space in the order in which it is written, regardless of the specific memory address to which it is written and uses that data as the source data in the current BitBLT operation. The block of bytes sent by the host CPU to this data port must be quadword-aligned, although the source data contained within the block of bytes does not need to be aligned. As mentioned earlier, the least significant three bits of the Source Address Register (BR06) are used to specify the number of bytes that must be skipped in the first quadword to reach the first byte of valid source data.

To accommodate discontinuous source data, the Source and Destination Offset Register (BR00) can be used to specify the offset in bytes from the beginning of one scan line's worth source data to the next. Otherwise, if the source data is contiguous, then an offset equal to the length of a scan line's worth of source data should be specified.

Monochrome Source Data

Bit 12 of the BitBLT Control Register (BR04) specifies whether the source data is color or monochrome. Since monochrome graphics data only uses one bit per pixel, each byte of monochrome source data typically carries data for 8 pixels which hinders the use of byte-oriented parameters when specifying the location and size of valid source data. Some additional parameters must be specified to ensure the proper reading and use of monochrome source data by the BitBLT engine. The BitBLT engine also provides additional options for the manipulation of monochrome source data versus color source data.

The various bit-wise logical operations and per-pixel write-masking operations were designed to work with color data. In order to use monochrome data, the BitBLT engine converts it into color through a process called color expansion, which takes place as a BitBLT operation is performed. In color expansion, the single bits of monochrome source data are converted into one, two, or three bytes (depending on the color depth to which the BitBLT engine has been set) of color data that are set to carry value corresponding to either the foreground or background color that have been specified for use in this conversion process. If a given bit of monochrome source data carries a value of 1, then the byte(s) of color data resulting from the conversion process will be set to carry the value of the foreground color. If a given bit of monochrome source data carries a value of 0, then the resulting byte(s) will be set to the value of the background color.

The foreground and background colors used in the color expansion of monochrome source data can be set in the Pattern/Source Expansion Foreground Color Register (BR02) and the Pattern/Source Expansion Background Color Register (BR01), in which case these colors will be the same colors as those used in the color expansion of monochrome pattern data. However, it is also possible to set the colors for the color expansion of monochrome source data independently of those set for the color expansion of monochrome pattern data by using the Source Expansion Foreground Color Register (BR0A) and the Source Expansion Background Color Register (BR09). Bit 27 in the BitBLT Monochrome Source Control Register (BR03) is used to select between one or the other of these two sets of registers.

The BitBLT engine requires that the alignment of each scan line's worth of monochrome source data be specified. In other words, whether each scan line's worth of monochrome source data can be assumed to start on quadword, doubleword, word, or byte boundaries, or that it cannot be assumed to start on any such boundary must be specified using bits 26-24 of the Monochrome Source Control Register (BR03).

The BitBLT engine also provides various clipping options for use with monochrome source data. Bits 21-16 of the Monochrome Source Control Register (BR03) allow the BitBLT engine to be programmed to skip up to 63 of the 64 bits in the first quadword of a block of monochrome source data to reach the first bit of valid source data. Depending on the width of the block of pixels represented by the monochrome source data, this option can also be used to implement a way of clipping the monochrome source data from the top. Bits 5-0 of this register allow up to 63 of the 64 bits in the first quadword in each scan line's worth of monochrome source data to be skipped to reach the first bit of valid source data in each scan line's worth. This option can be used to implement the clipping of each scan line's worth of monochrome source data from the left. Bits 13-8 of this register provides similar functionality for clipping monochrome source data from the right.

Pattern Data

The pattern data must exist within the frame buffer where the BitBLT engine may read it directly. The host CPU cannot provide the pattern data to the BitBLT engine. As shown in Figure E-8, the block of pattern graphics data always represents a block of 8x8 pixels. The bits or bytes of a block of pattern data may be organized in the frame buffer memory in only one of four ways, depending upon its color depth which may be 8, 16, or 24 bits per pixel (whichever matches the color depth to which the BitBLT engine has been set), or monochrome.

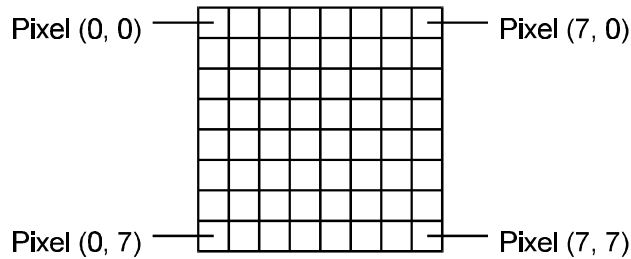

Figure E- 8: Pattern Data
(Always an 8x8 Array of Pixels)

The Pattern Address Register (BR05) is used to specify the address of the pattern data as an offset from the beginning of the frame buffer at which the block of pattern data begins. The three least significant bits of the address written to this register are ignored, because the address must be in terms of quadwords. This is because the pattern must always be located on an address boundary equal to its size. Monochrome patterns take up 8 bytes, or a single quadword of space, and therefore, must be located on a quadword boundary. Similarly, color patterns with color depths of 8 and 16 bits per pixel must start on 64-byte and 128-byte boundaries, respectively. Color patterns with color depths of 24 bits per pixel must start on 256-byte boundaries, despite the fact that the actual color data fills only 3 bytes per pixel.

Figures E-9, E-10, E.3-11, and E-12 show how monochrome, 8bpp, 16bpp, and 24bpp pattern data is organized in memory.

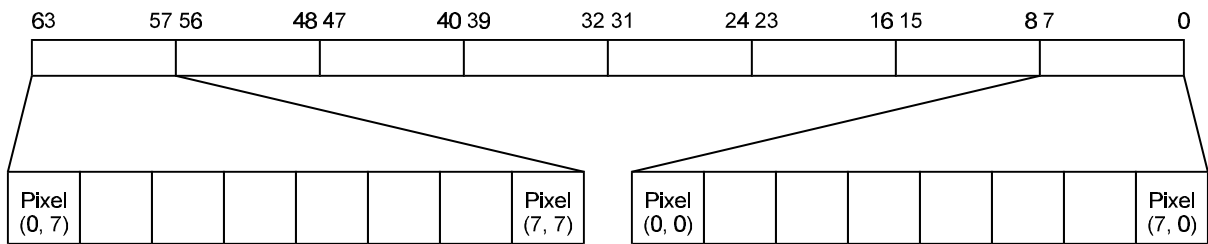

Figure E-9: Monochrome Pattern Data -- Occupies a Single Quadword

63	57 56	48 47	40 39	32 31	24 23	16 15	8 7	0	
Pixel (7, 0)								Pixel (0, 0)	00h
									08h
									10h
									18h
									20h
									28h
									30h
Pixel (7, 7)								Pixel (0, 7)	38h

Figure E-10: 8bpp Pattern Data -- Occupies 64 Bytes (8 Quadwords)

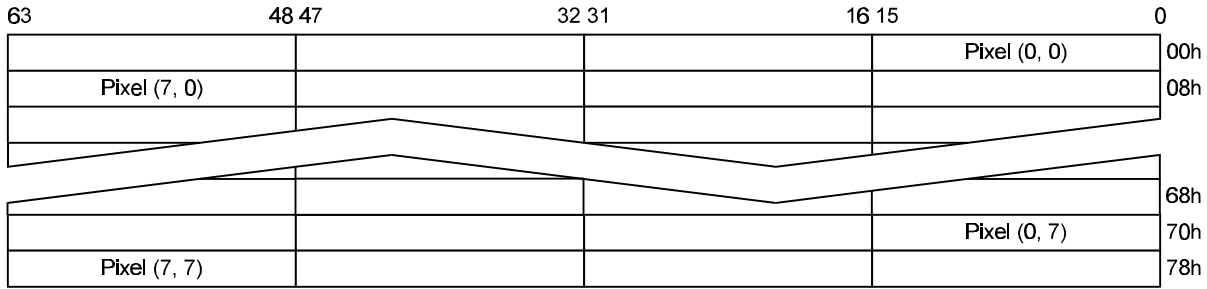

Figure E-11: 16bpp Pattern Data -- Occupies 128 Bytes (16 Quadwords)

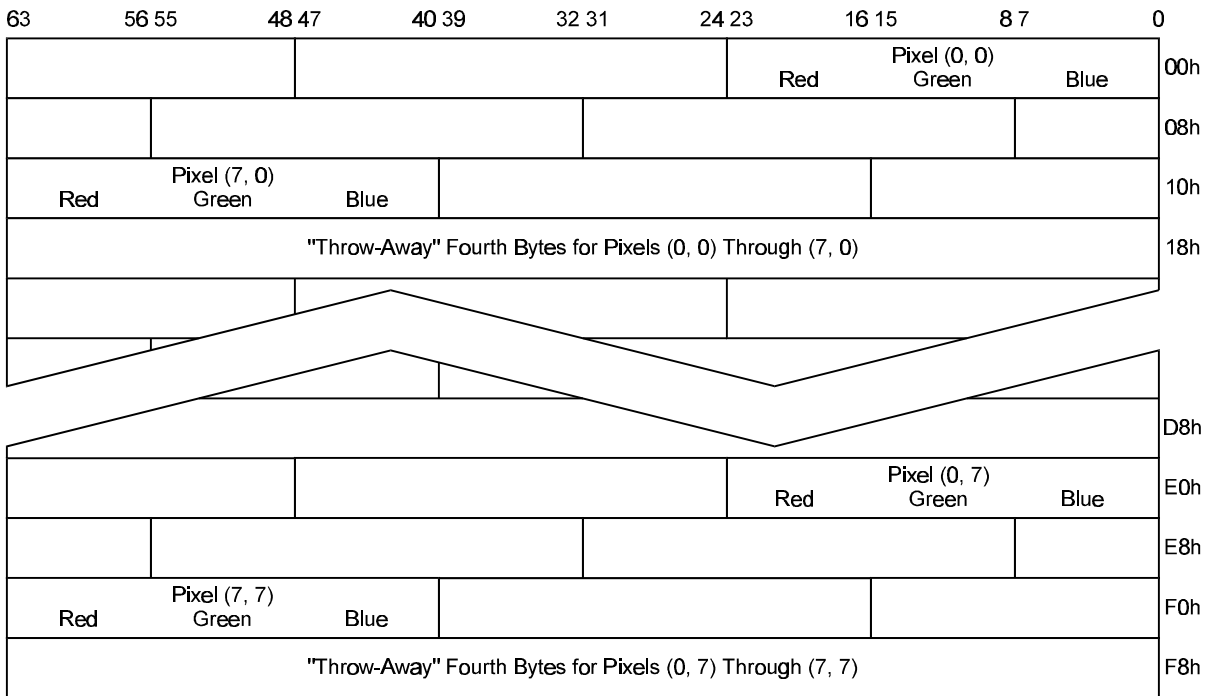

Figure E-12: 24bpp Pattern Data -- Occupies 256 Bytes (32 Quadwords)

As is shown in Figure E-12, there are four bytes allocated for each pixel on each scan line's worth of pattern data, which allows each scan line's worth of 24bpp pattern data to begin on a 32-byte boundary. The extra ("fourth") unused bytes of each pixel on a scan line's worth of pattern data are collected together in the last 8 bytes (the last quadword) of each scan line's worth of pattern data.

Bit 18 of the BitBLT Control Register (BR04) specifies whether the pattern data is color or monochrome. The various bit-wise logical operations and per-pixel write-masking operations were designed to work with color data. In order to use monochrome pattern data, the BitBLT engine is designed to convert it into color through a process called "color expansion" which takes place as a BitBLT operation is performed. In color expansion, the single bits of monochrome pattern data are converted into one, two, or three bytes (depending on the color depth to which the BitBLT engine has been set) of color data that are set to carry values corresponding to either the foreground or background color that have been specified for use in this process. The foreground color is used for pixels corresponding to a bit of monochrome pattern data that carry the value of 1, while the background color is used where the corresponding bit of monochrome pattern data carries the value of 0. The foreground and background colors used in the color expansion of monochrome pattern data can be set in the Pattern/Source Expansion Foreground Color Register (BR02)

and Pattern/Source Expansion Background Color Register (BR01). Depending upon the setting of bit 27 in the Monochrome Source Control Register (BR03), these same two registers may also specify the foreground and background colors to be used in the color expansion of the source data.

Destination Data

If the destination is within the frame buffer, then there are actually two different types of “destination data”: the graphics data already residing at the location that is designated as the destination, and the data that is to be written into that very same location as a result of a BitBLT operation. If, however, the destination is selected so that the BitBLT engine is to provide its output to the host CPU, then the destination data provided to the host CPU is the only kind there is.

Blocks of destination data to be read from and written to the destination may be either contiguous or discontinuous. All data written to the destination will have the color depth to which the BitBLT engine has been set. It is presumed that any data already existing at the destination which will be read by the BitBLT engine will also be of this same color depth — the BitBLT engine neither reads nor writes monochrome destination data.

Bit 11 of the BitBLT Control Register (BR04) is used to specify whether the destination data is to be written to a location within the frame buffer, or is to be provided to the host CPU. If the destination is within the frame buffer, the Destination Address Register (BR07) is used to specify the address of the destination as an offset from the beginning of the frame buffer at which the destination location begins. Otherwise, only bits 2-0 of the Destination Address Register (BR07) are used, and their purpose is to specify which byte in the first quadword of destination data provided to the host CPU is the first byte of actual destination data. To accommodate discontinuous destination data, the Source and Destination Offset Register (BR00) can be used to specify the offset in bytes from the beginning of one scan line’s worth of destination data to the next. Otherwise, if the destination data is contiguous, then an offset equal to the length of a scan line’s worth of destination data should be specified.

BitBLT Programming Examples

Pattern Fill -- A Very Simple BitBLT

In this example, a rectangular area on the screen is to be filled with a color pattern stored as pattern data in off-screen memory. The screen has a resolution of 1024x768 and the graphics system has been set to a color depth of 8 bits per pixel.

As shown in Figure E-13, the rectangular area to be filled has its upper left-hand corner at coordinates (128, 128) and its lower right-hand corner at coordinates (191, 191). These coordinates define a rectangle covering 64 scan lines, each scan line's worth of which is 64 pixels in length — in other words, an array of 64x64 pixels. Presuming that the pixel at coordinates (0, 0) corresponds to the byte at address 00h in the frame buffer memory, the pixel at (128, 128) corresponds to the byte at address 20080h.

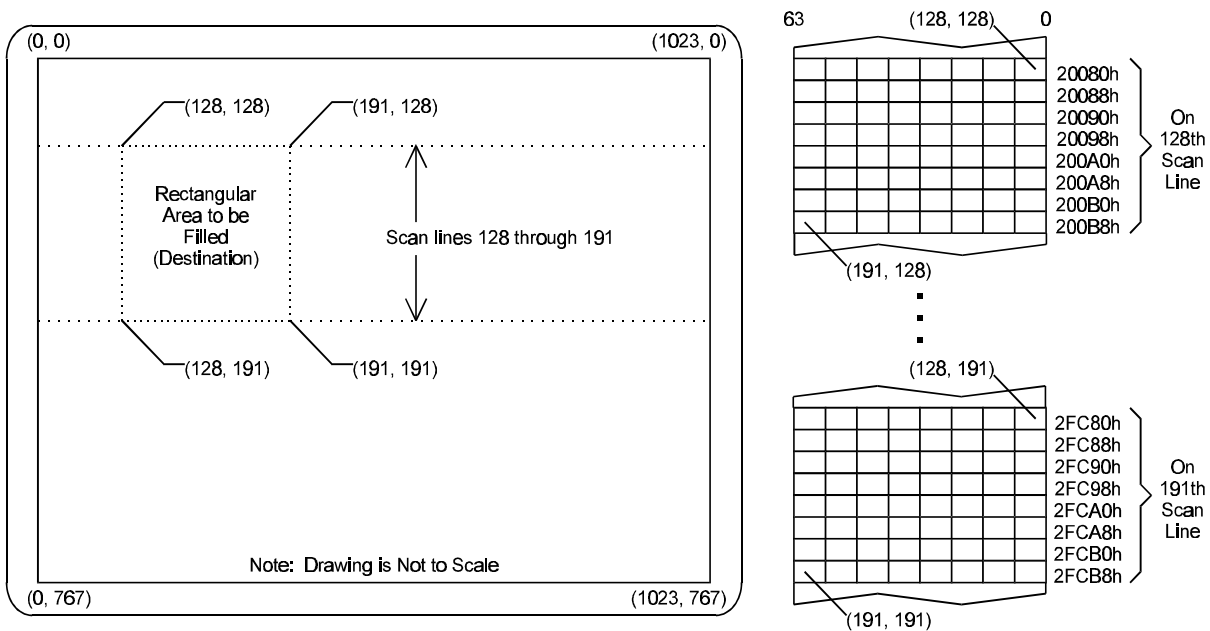

Figure E-13: On-Screen Destination for Example Pattern Fill BitBLT

As shown in Figure E-14, the pattern data occupies 64 bytes starting at address 100000h. As always, the pattern data represents an 8x8 array of pixels.

Before programming the BitBLT engine in any way, bit 0 of the BitBLT Configuration Register (XR20) or bit 31 of the BitBLT Control Register (BR04) should be checked to see if the BitBLT engine is currently busy. The BitBLT engine should not be programmed in any way until all BitBLT operations are complete and the BitBLT engine is idle. Once the BitBLT engine is idle, programming the BitBLT engine for the operation in this example should begin by making sure that the BitBLT Configuration Register (XR20) is set to 00h, in order to specify a color depth of 8 bits per pixel and enable normal operation. Alternatively, if bit 23 of the BitBLT Control Register (BR04) is set to 1, then the color depth of the BitBLT engine may be set to 8 bits per pixel by setting bits 25 and 24 of the same register to 0, although it is still necessary to ensure that at least bit 1 of the BitBLT Configuration Register is set to 0 to enable normal operation.

The BitBLT Control Register (BR04) is used to select the features to be used in this BitBLT operation, and must be programmed carefully. Bits 22-20 should be set to 0 to select the top-most horizontal row of the pattern as the starting row used in drawing the pattern starting with the top-most scan line covered by the destination. Since actual pattern data will be used, bit 19 should be set to 0. The pattern data is in color with a color depth of 8 bits per pixel, so bits 18 and 17 should also be set to 0. Since this BitBLT operation

does not use per-pixel write-masking, bits 16-13 should be set to 0. Bit 12 should be set to 0 to ensure that the settings in the Monochrome Source Control Register (BR03) will have no effect on this BitBLT operation. Bit 11 should be set to 0 to configure the BitBLT engine for a destination within the frame buffer. The setting of bits 10-8 do not affect this BitBLT operation, since source data is not used. Therefore, these bits might as well be set to zero as a default. Finally, bits 7-0 should be programmed with the 8-bit value of F0h to select the bit-wise logical operation in which a simple copy of the pattern data to the destination takes place. Selecting this bit-wise operation in which no source data is used as an input causes the BitBLT engine to automatically forego either reading source data from the frame buffer or waiting for the host CPU to provide it.

Bits 28-16 of the Source and Destination Offset Register (BR00) must be programmed with number of bytes in the interval from the start of one scan line's worth of destination data to the next. Since the color depth is 8 bits per pixel and the horizontal resolution of the display is 1024, the value to be programmed into these bits is 400h, which is equal to the decimal value of 1024. Since this BitBLT operation does not use source data, the BitBLT engine ignores bits 12-0.

Bits 22-3 of the Pattern Address Register (BR05) must be programmed with the address of the pattern data. This address is specified as an offset from the beginning of the frame buffer where the pattern data begins. In this case, the address is 100000h.

Similarly, bits 22-0 of the Destination Address Register (BR07) must be programmed with the address of the destination, i.e., the offset from the beginning of the frame buffer of the byte at the destination that will be written to first. In this case, the address is 20080h, which corresponds to the byte representing the pixel at coordinates (128, 128).

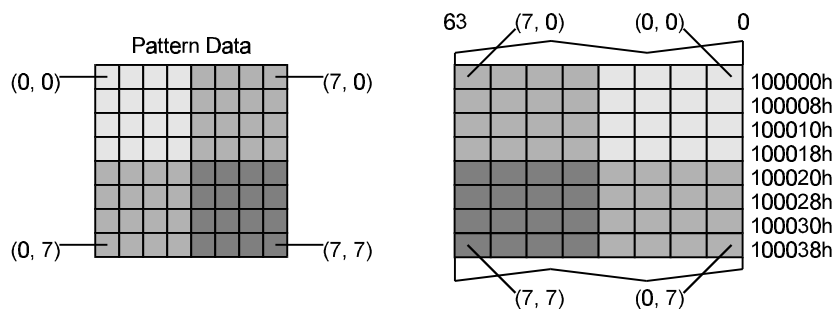

Figure E-14: Pattern Data for Example Pattern Fill BitBLT

This BitBLT operation does not use the values in the Pattern/Source Expansion Background Color Register (BR01), the Pattern/Source Expansion Foreground Color Register (BR02), the Monochrome Source Control Register (BR03), the Source Address Register (BR06), the Source Expansion Background Color Register (BR09), or the Source Expansion Foreground Color Register (BR0A).

The Destination Width and Height Register (BR08) must be programmed with values that describe to the BitBLT engine the 64x64 pixel size of the destination location. Bits 28-16 should be set to carry the value of 40h, indicating that the destination location covers 64 scan lines. Bits 12-0 should be set to carry the value of 40h, indicating that each scan line's worth of destination data occupies 64 bytes. The act of writing a non-zero value for the height to the Destination Width and Height Register (BR08) is what signals the BitBLT engine to begin performing this BitBLT operation. Therefore, it is important that all other programming of the BitBLT registers be completed before this is done.

Figure E-15 shows the end result of performing this BitBLT operation. The 8x8 pattern has been repeatedly copied ("tiled") into the entire 64x64 area at the destination.

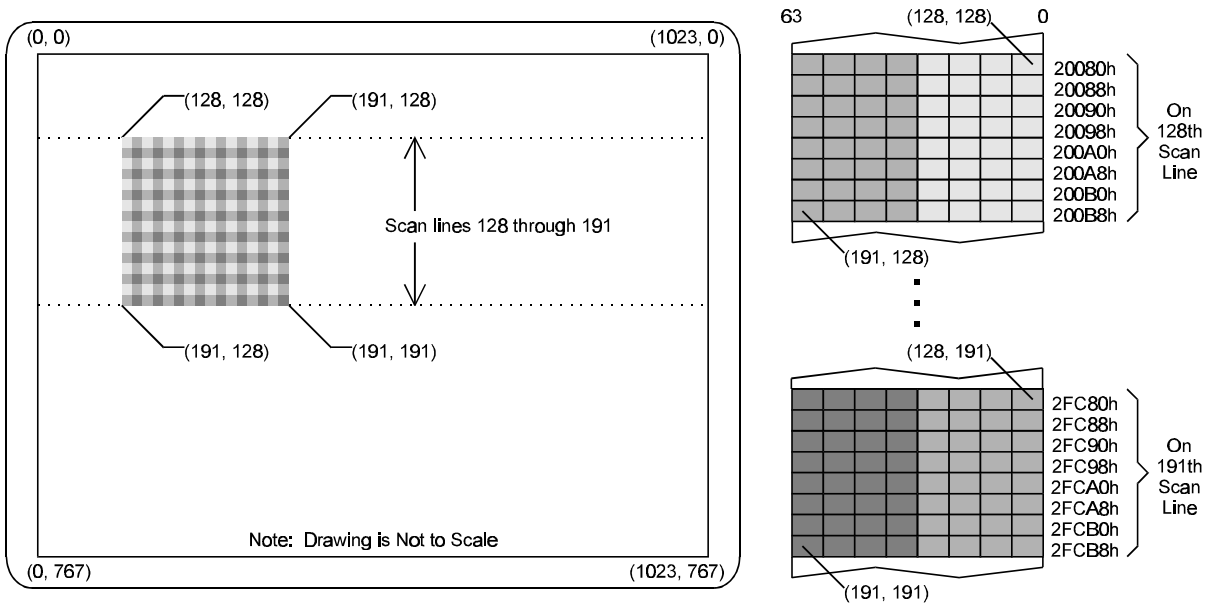

Figure E-15: Results of Example Pattern Fill BitBLT

Drawing Characters Using a Font Stored in System Memory

In this example BitBLT operation, a lowercase letter "f" is to be drawn in black on a display with a gray background. The resolution of the display is 1024x768, and the graphics system has been set to a color depth of 8 bits per pixel. Figure E-16 shows the display on which this letter "f" is to be drawn. As shown in this figure, the entire display is shaded gray. The letter "f" is to be drawn into an 8x8 region on the display with the upper left-hand corner at the coordinates (128, 128).

Figure E-17 shows both the 8x8 pattern making up the letter “f” and how it is represented somewhere in the host’s system memory — the actual address in system memory is not important. The letter “f” is represented in system memory by a block of monochrome graphics data that occupies 8 bytes. Each byte carries the 8 bits needed to represent the 8 pixels in each scan line’s worth of this graphics data. This type of pattern is often used to store character fonts in system memory.

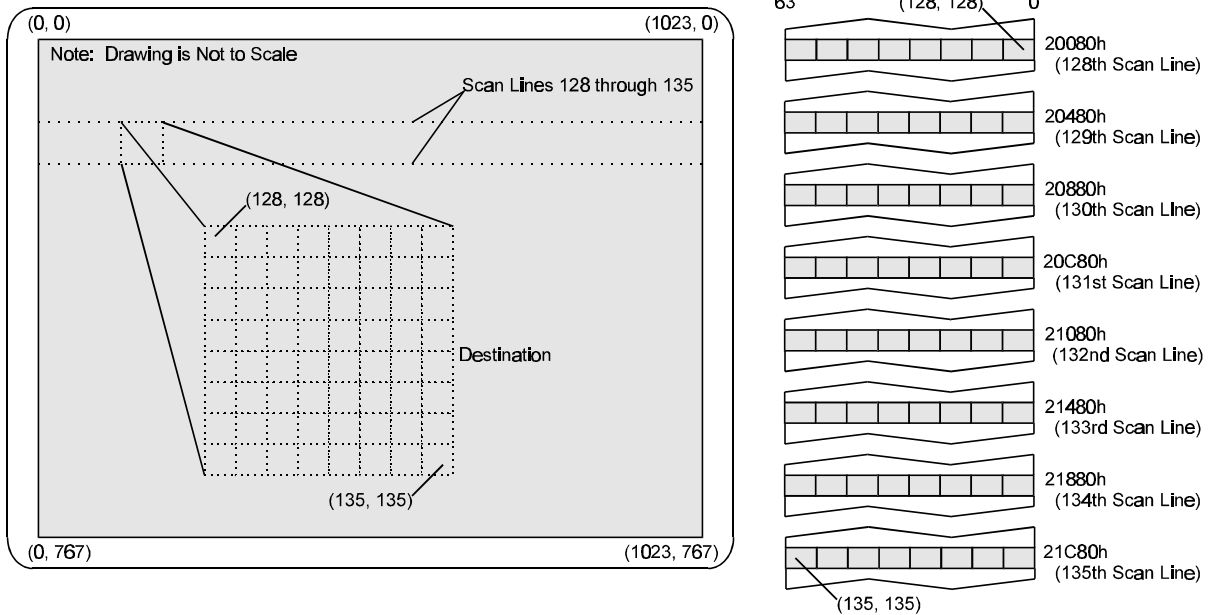

Figure E-16: On-Screen Destination for Example Character Drawing BitBLT

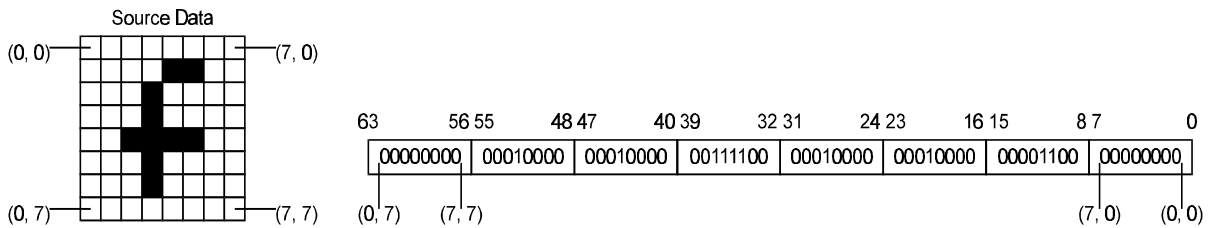

Figure E-17: Source Data in System Memory for Example Character Drawing BitBLT

During this BitBLT operation, the host CPU will read this representation of the letter “f” from system memory, and write it to the BitBLT engine by performing memory writes to the BitBLT data port. The BitBLT engine will receive this data from the host CPU and use it as the source data for this BitBLT operation. The BitBLT engine will be set to the same color depth as the graphics system (8 bits per pixel, in this case). Since the source data in this BitBLT operation is monochrome, color expansion must be used to convert it to an 8 bpp color depth. To ensure that the gray background behind this letter “f” is preserved, per-pixel write masking will be performed, using the monochrome source data as the pixel mask.

As in the example of the pattern fill BitBLT operation, the first step before programming the BitBLT engine in any way is to check either bit 0 of the BitBLT Configuration Register (XR20) or bit 31 of the BitBLT Control Register (BR04) to see if the BitBLT engine is currently busy. After waiting until the BitBLT engine is idle,

programming the BitBLT engine should begin by making sure that the BitBLT Configuration Register (XR20) is set to 00h, to specify a color depth of 8 bits per pixel and to enable normal operation. Alternatively, if bit 23 of the BitBLT Control Register (BR04) is set to 1, then the color depth of the BitBLT engine may be set to 8 bits per pixel by setting bits 25 and 24 of the same register to 0, although it is still necessary to ensure that at least bit 1 of the BitBLT Configuration Register is set to 0 to enable normal operation.

The BitBLT Control Register (BR04) is used to select the features to be used in this BitBLT operation. Since pattern data is not required for this operation, the BitBLT engine will ignore bits 22-17, however as a default, these bits can be set to 0. Since monochrome source data will be used as the pixel mask for the per-pixel write-masking operation used in this BitBLT operation, bits 16-14 must be set to 0, while bit 13 should be set to 1. Bit 12 should be set to 1, to specify that the data source is monochrome. Bit 11 should be set to 0 to configure the BitBLT engine for a destination within the frame buffer. Bit 10 should be set to 1, to indicate that the source data will be provided by the host CPU. Presuming that the host CPU will provide the source data starting with the byte that carries the left-most pixel on the top-most scan line's worth of the source data, bits 9 and 8 should both be set to 0. Finally, bits 7-0 should be programmed with the 8-bit value CCh to select the bit-wise logical operation that simply copies the source data to the destination. Selecting this bit-wise operation in which no pattern data is used as an input, causes the BitBLT engine to automatically forego reading pattern data from the frame buffer.

Unlike the earlier example of a pattern fill BitBLT operation where the Monochrome Source Control Register (BR03) was entirely ignored, several features of this register will be used in this BitBLT operation. Bit 27 of this register will be set to 0, thereby selecting the Pattern/Source Expansion Foreground Color Register (BR02) to specify the color with which the letter "f" will be drawn. This example assumes that the source data will be sent in one quadword that will be quadword-aligned. Therefore, bits 26, 25, and 24, which specify alignment should be set to 1, 0, and 1, respectively. Since clipping will not be performed in this BitBLT operation, bits 21-16, 13-8, and 5-0 should all be set to 0.

Bits 28-16 of the Source and Destination Offset Register (BR00) must be programmed with a value equal to number of bytes in the interval between the first bytes of each adjacent scan line's worth of destination data. Since the color depth is 8 bits per pixel and the horizontal resolution of the display is 1024 pixels, the value to be programmed into these bits is 400h, which is equal to the decimal value of 1024. Since the source data used in this BitBLT operation is monochrome, the BitBLT engine will not use a byte-oriented offset value for the source data. Therefore, bits 12-0 will be ignored.

Since the source data is monochrome, color expansion is required to convert it to color with a color depth of 8 bits per pixel. Since the Pattern/Source Expansion Foreground Color Register (BR02) was selected to specify the foreground color of black to be used in drawing the letter "f", this register must be programmed with the value for that color. With the graphics system set for a color depth of 8 bits per pixel, the actual colors are specified in the RAMDAC palette, and the 8 bits stored in the frame buffer for each pixel actually specify the index used to select a color from that palette. This example assumes that the color specified at index 00h in the palette is black, and therefore bits 7-0 of this register should be set to 00h to select black as the foreground color. The BitBLT engine ignores bits 23-8 of this register because the selected color depth is 8 bits per pixel. Even though the color expansion being performed on the source data normally requires that both the foreground and background colors be specified, the value used to specify the background color is not important in this example. Per-pixel write-masking is being performed with the monochrome source data as the pixel mask, which means that none of the pixels in the source data that will be converted to the background color will ever be written to the destination. Since these pixels will never be seen, the value programmed into the Pattern/Source Expansion Background Color Register (BR01) to specify a background color is not important.

Since the CPU is providing the source data, and this source data is monochrome, the BitBLT engine ignores all of bits 22-0 of the Source Address Register (BR06).

Bits 22-0 of the Destination Address Register (BR07) must be programmed with the address of the destination data. This address is specified as an offset from the start of the frame buffer of the pixel at the destination that will be written to first. In this case, the address is 20080h, which corresponds to the byte representing the pixel at coordinates (128, 128).

This BitBLT operation does not use the values in the Pattern Address Register (BR05), the Source Expansion Background Color Register (BR09), or the Source Expansion Foreground Color Register (BR0A).

The Destination Width and Height Register (BR08) must be programmed with values that describe to the BitBLT engine the 8x8 pixel size of the destination location. Bits 28-16 should be set to carry the value of 8h, indicating that the destination location covers 8 scan lines. Bits 12-0 should be set to carry the value of 8h, indicating that each scan line's worth of destination data occupies 8 bytes. As mentioned in the previous example, the act of writing a non-zero value for the height to the Destination Width and Height Register (BR08) provides the BitBLT engine with the signal to begin performing this BitBLT operation. Therefore, it is important that all other programming of the BitBLT engine registers be completed before this is done.

Figure E-18 shows the end result of performing this BitBLT operation. Only the pixels that form part of the actual letter "F" have been drawn into the 8x8 destination location on the display, leaving the other pixels within the destination with their original gray color.

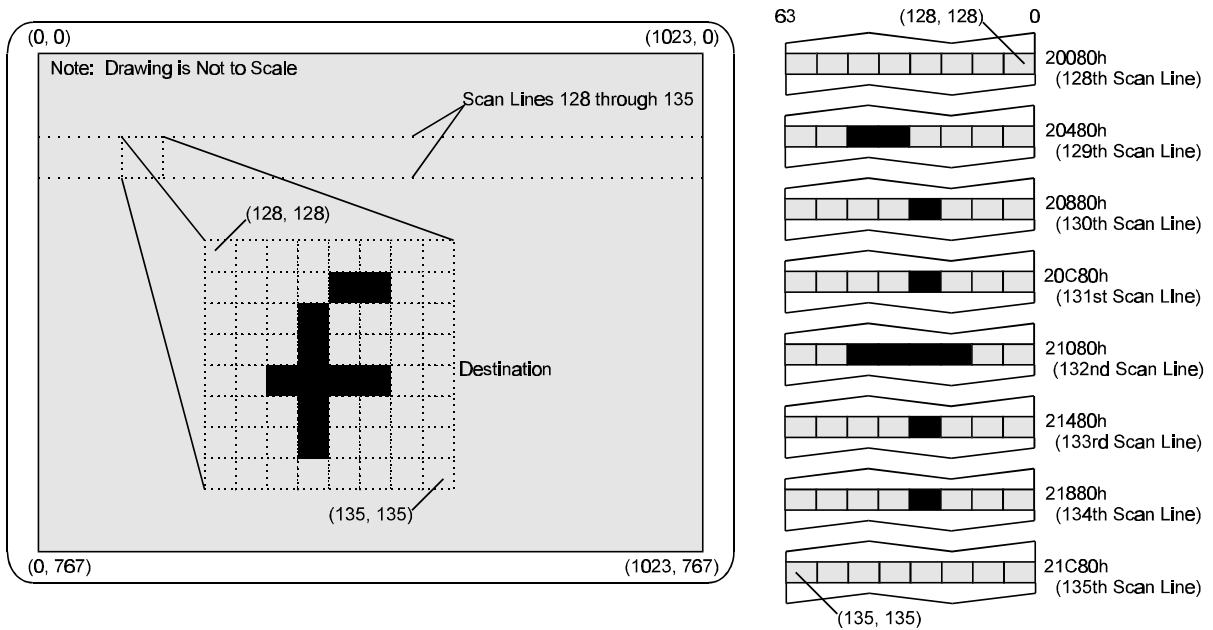

Figure E-18: Results of Example Character Drawing BitBLT



A SUBSIDIARY OF INTEL CORPORATION

Chips and Technologies, Inc.
2950 Zanker Road
San Jose, California 95134
Phone: 408-434-0600
FAX: 408-894-2077

Title:
Publication No.:
Stock No.:
Revision No.:
Date:

69000 Data Book
DB181.2
010-181-002
1.2
03/09/98