

T-74-07-01

SL561

ULTRA LOW NOISE PREAMPLIFIERS

This integrated circuit is a high gain, low noise preamplifier designed for use in audio and video systems at frequencies up to 6MHz. Operation at low frequencies is eased by the small size of the external components and the low 1/f noise. Noise performance is optimised for source impedances between 20Ω and 1kΩ making the device suitable for use with a number of transducers including photo-conductive IR detectors, magnetic tape heads and dynamic microphones. The SL561B is only available in the TO-5 package. The SL561C is only available in the Plastic package.

FEATURES

- High Gain 60dB
- Low noise 0.8nV/√Hz (Rs = 50Ω)
- Bandwidth 6MHz
- Low Power Consumption 10mW (V_{CC} = 5V)

APPLICATIONS

- Audio Preamplifiers (low noise from low impedance source)
- Video Preamplifier
- Preamplifier for use in Low Cost Infra-Red Systems

ORDERING INFORMATION

- SL561 AC CM
- SL561 B CM
- SL561 BB CM
- SL561 C DP

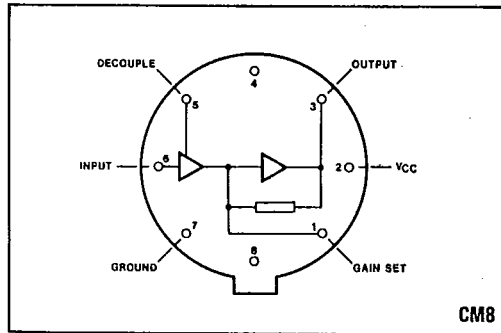

Fig.1 Pin connections (viewed from above) SL561B

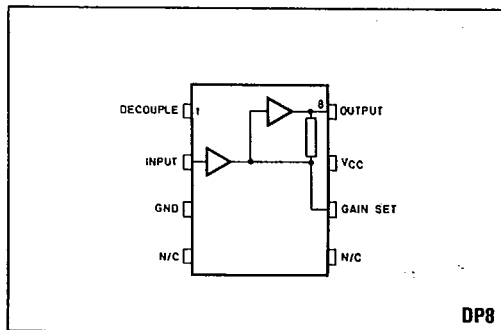

Fig.2 Pin connections (viewed from above) SL561C

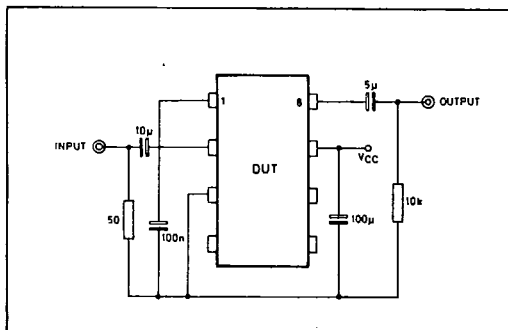

Fig.3 Test circuit

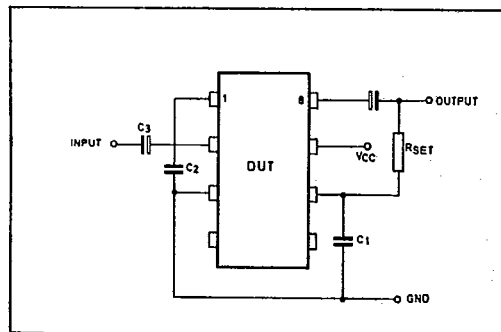

Fig.4 Typical application

SL561

T-74-07-01

ELECTRICAL CHARACTERISTICS

Test conditions (unless otherwise stated):

V_{cc} 5V
 Source impedance 50 Ω
 Load impedance 10k Ω
 T_{amb} 25°C

SL561B

Characteristic	Value			Units	Conditions
	Min.	Typ.	Max.		
Voltage gain	57	60	63	dB	Pin 1 O/C
Equivalent input noise voltage		0.8	1.2	nV/ $\sqrt{\text{Hz}}$	100Hz to 6MHz
Output voltage	2	3		V p-p	See note
Supply current		2.0	3.0	mA	
Output resistance		50		Ω	
Input resistance		3		k Ω	
Input capacitance		15		pF	
Upper cut-off frequency	5	6.5		MHz	$V_{out} = 10\text{mV p-p}$
		6.2		MHz	$V_{out} = 1.5\text{V p-p}$

SL561C

Characteristic	Value			Units	Conditions
	Min.	Typ.	Max.		
Voltage gain	57	60	63	dB	Pin 6 O/C
Equivalent input noise voltage		0.8		nV/ $\sqrt{\text{Hz}}$	100Hz to 6MHz
Input resistance		3		k Ω	
Input capacitance		15		pF	
Output impedance		50		Ω	
Output voltage	2	3		V p-p	See note
Supply current		2	3	mA	
Bandwidth		6		MHz	

OPERATING NOTES (Pin numbers refer to DIL package)

Upper cut-off Frequency

The bandwidth of the amplifier can be reduced from 6MHz to any desired value by a capacitor from pin 6 to ground. This is shown in Fig.5. No degradation in noise or output swing occurs when this capacitor is used. The high frequency roll off is approximately 6dB/octave.

Low frequency response

The capacitors C_2 and C_3 (Fig.4) determine the lower cut-off frequency. C_2 decouples an internal feedback loop and if its value is close to that of C_3 an increase in gain at low frequencies can occur. For a flat response either make C_2 less than 0.05 C_3 or make C_2 greater than 5 C_3 .

Gain set facility

Provision is made to adjust the gain by means of a resistor between pin 6 and the output. Gains as low as 10dB can be selected. This resistor increases the feedback around the output stage and stability problems can result if the bandwidth of the amplifier is not reduced as indicated in Note 1. Fig.6 shows recommended values of C_1 for each gain range. Since the input stage is a common emitter stage without emitter degeneration (for best noise) at values of gain less than 40dB this input stage, rather than the output

stage, determines the maximum output voltage swing. For a distortion of less than 10% the input voltage should be restricted to less than 5mV (see Fig.9).

Driving low impedance loads

The quiescent current of the output emitter follower is 0.5mA. If larger voltage swings are required into low impedance loads this current can be increased by a resistor from pin 8 to ground. To avoid exceeding the ratings of the output transistor the resistor should not be less than 200 Ω .

Noise performance

The equivalent input voltage for the amplifier is shown in Fig.7 From this the input noise voltage and current generators can be derived. They are:

$$e_n = 0.8\text{nV}/\sqrt{\text{Hz}}$$

$$i_n = 2.0\text{pA}/\sqrt{\text{Hz}}$$

Flicker or 1/f noise is not normally a problem, the knee frequency being typically below 100Hz.

ABSOLUTE MAXIMUM RATINGS

Supply voltage	10V
Storage temperature range	-55°C to +125°C
Operating temperature range DIL	-55°C to +100°C
Operating temperature range TO5	-55°C to +125°C

T-74-07-01

SL561

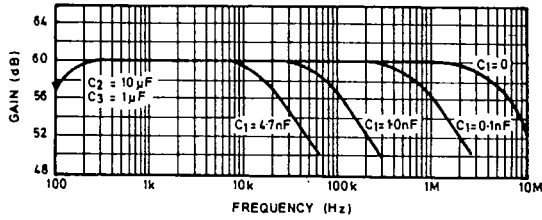

Fig.5 Gain v. frequency

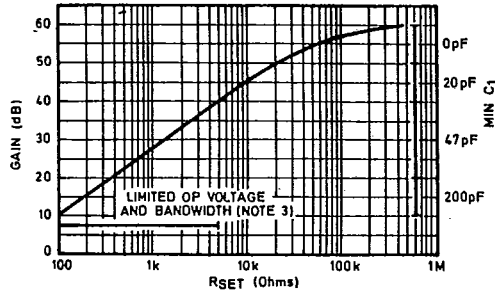

Fig.6 Gain v. R_{set}

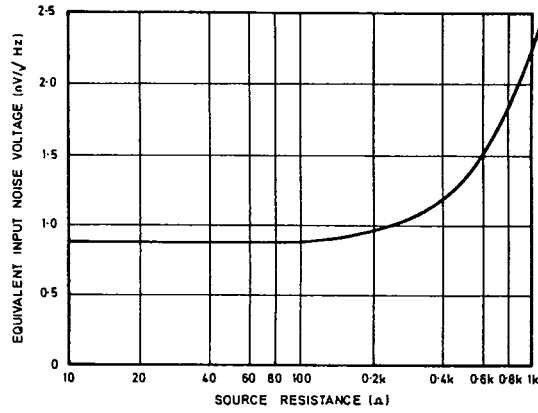

Fig.7 Noise v. source impedance

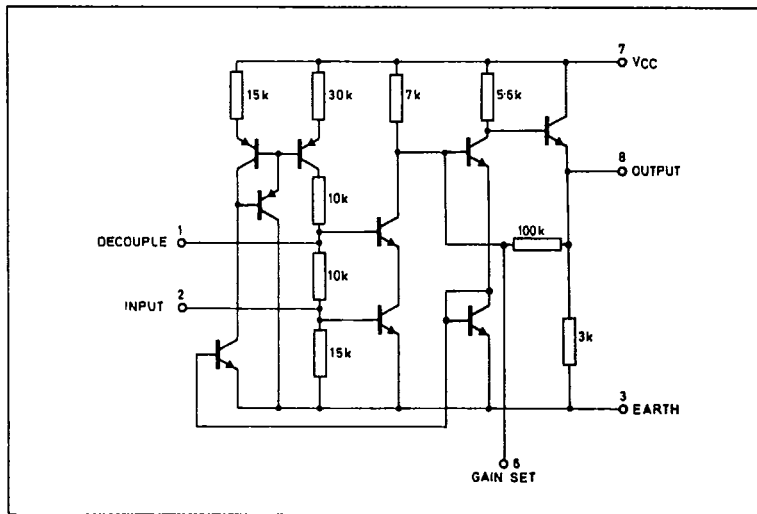

Fig.8 Circuit diagram

SL561

T-74-07-01

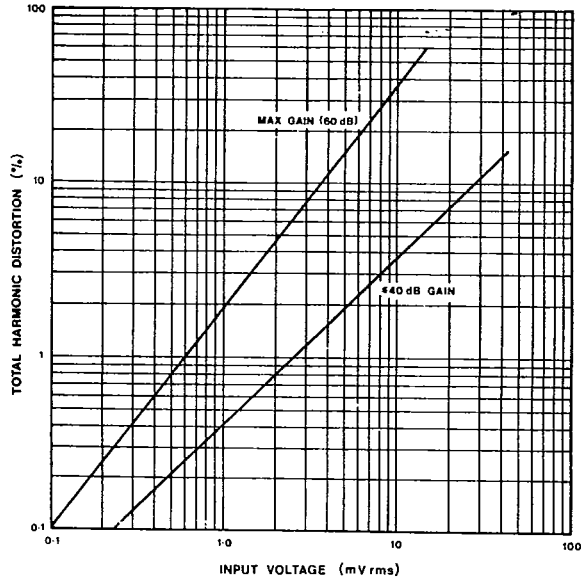

Fig.9 Harmonic distortion SL561 at 20kHz