

The MA17503 Interrupt Unit is a component of the MAS281 chip set. Other chips in the set include MA17501 Execution Unit and the MA17502 Control Unit. Also available is the peripheral MA31751 Memory Management/Block Protection Unit. The Interrupt Unit, in conjunction with these additional chips, implements the full MIL-STD-1750A Instruction Set Architecture.

The MA17503 - consisting of the Pending Interrupt Register, Mask Register, Interrupt Priority Encoder, Fault Register, Timer A, Timer B, Trigger-Go Counter, Bus Fault Timer, and DMA interface - handles all interrupt fault, and DMA interfacing, in addition to providing all three hardware timers. The Interrupt Unit also implements 26 of the MIL-STD-1750A specified I/O commands. Table 1 provides brief signal definitions.

The MA17503 is offered in dual-in-line, flatpack or leadless chip carrier packaging. Screening and packaging options are described at the end of this document.

FEATURES

- Mil-Std-1750A Instruction Set Architecture
- Full Performance over Military Temperature Range (-55°C to +125°C)
- Radiation Hard CMOS/SOS Technology
- Interrupt Handler
 - 9 User Interrupt Inputs
 - Pending Interrupt Register
 - Interrupt Mask Register
 - Interrupt Priority Encoder
- Fault Handler
 - 8 User Faults Inputs
 - Fault Register
- Timers
 - Timer A
 - Timer B
- Trigger-Go
- DMA Interface
- Interface Discrettes
 - Normal Power-Up
 - Start-Up ROM Enable
 - Configuration Word Enable
- Implements 26 MIL-STD-1750A Specified I/O Commands
- MAS281 Integrated Built-In Self Test
- TTL Compatible System Interface

BLOCK DIAGRAM

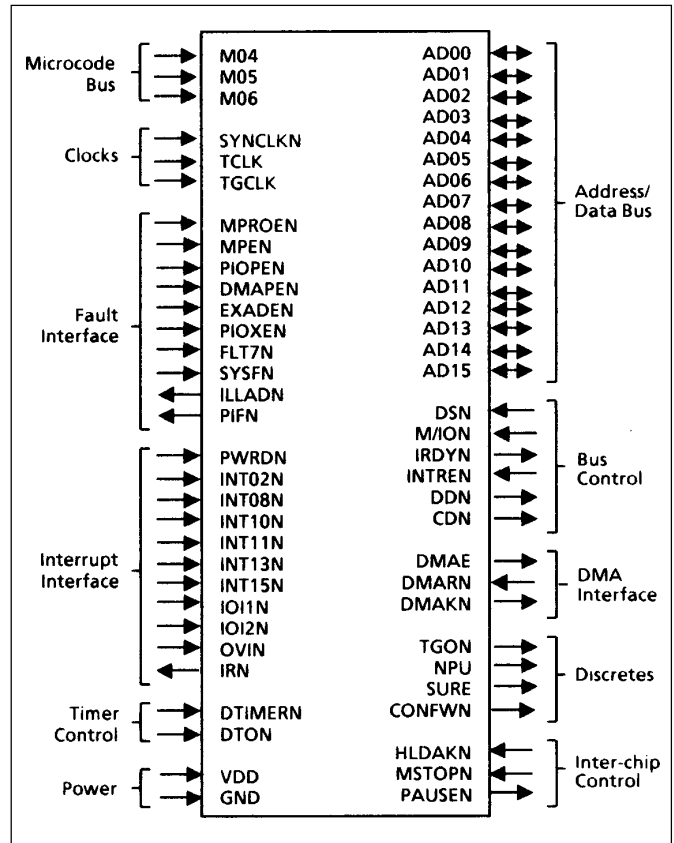

MA17503

1.0 SYSTEM CONSIDERATIONS

The MA17503 Interrupt Unit (IU) is a component of the GPS MAS281 chip set. This chip set implements the full MIL-STD-1750A instruction set architecture. Other chips in the set include the MA17501 Execution Unit (EU) and MA17502 Control Unit (CU). Also available is the peripheral MA31751 Memory Management Unit/Block Protection Unit (MMU(BPU)). Figure 1 depicts the relationship between the chip set components.

The IU provides the interrupt and fault handling interfaces for the chip set. The IU also provides the DMA control interface logic, contains interval Timers A and B, the Trigger-Go Counter, the Bus Fault Timeout timer, and decodes all MIL-STD-1750A specified I/O commands in support of these functions. The EU provides the arithmetic and logical computation resources for the chip set. The EU and IU are each controlled by microcode from the CU. The MMU(BPU) may be configured to provide either 1M-word memory management (MMU) and/or 1K-word memory block write protection (BPU) functions.

As shown in Figure 1, the MAS281 is the minimum processor configuration consisting of an Execution Unit, a Control Unit, and an Interrupt Unit. This configuration is capable of accessing a 64K-word address space. Addition of a MMU configured MA31751 allows access to a 1M-word address space. Addition of a BPU configured MA31751 provides hardware support for 1K-word memory block write protection.

The IU, as with all components of the MAS281 chip set, is fabricated with CMOS/SOS process technology.

Detailed descriptions of the IUs companion chips are provided in separate data sheets. Additional discussions on chip set system considerations, interconnection details, and Digital Avionics Instruction Set (DAIS) mix benchmarking analysis are provided in separate application notes.

SIGNAL	I/O	DEFINITION
AD00 - AD15	I/O/Z	16-Bit Address/Data Bus
M04, M05, M06	I	3 Bits of the Microcode Instruction Word
INTREN	I	Interrupt Unit Microcode Interface Enable
DMAKN	O	DMA Request Acknowledge
DMAE	O	DMA Interface Enable
DMARN	I	DMA Request
M/ION	I	Memory/Input-Output
DSN	I	Data Strobe
SYNCLKN	I	Synchronisation Clock
IRDYN	O	Interrupt Unit Ready
DDN	O	Data Transceiver Direction Control
CDN	O	Control Bus Transceiver Direction Control
SYSFN	I	System Fault
FLT7N	I	Fault 7 (Undefined Fault)
PIOXEN	I	Programmed I/O Transfer Error
EXADEN	I	External Address Error
DMAPEN	I	DMA Parity Error
PIOPEN	I	Programmed I/O Parity Error
MPEN	I	Memory Parity Error
MPROEN	I	Memory Protection Error
ILLADN	O	Illegal Address
PIFN	O	Instruction Abort
PWRDN	I	Power-Down Interrupt
INT02N	I	Level 2 Interrupt
INT08N	I	Level 8 Interrupt
INT10N	I	Level 10 Interrupt
INT11N	I	Level 11 Interrupt
IO11N	I	I/O Register Interrupt 1
INT13N	I	Level 13 Interrupt
IO12N	I	I/O Register Interrupt 2
INT15N	I	Level 15 Interrupt
OV1N	I	Fixed-Point Overflow Interrupt
IRN	O	Interrupt Request
TCLK	I	Clock for Timers A and B
TGCLK	I	Trigger Go Timer Clock
DTIMERN	I	Disable Timers
DTON	I	Disable Bus-Fault Timeout
TGON	O	Trigger-Go Timer Overflow
NPIJ	O	Normal Power-up Indicator
SURE	O	Start-up ROM Enable
CONFVN	O	Configuration Word Enable
HLDACKN	I	Hold Acknowledge
MSTOPN	I	Microcode Stop
PAUSE	O	Processor Pause
VDD	I	Power
GND	I	Ground

Table 1: Signal Definitions

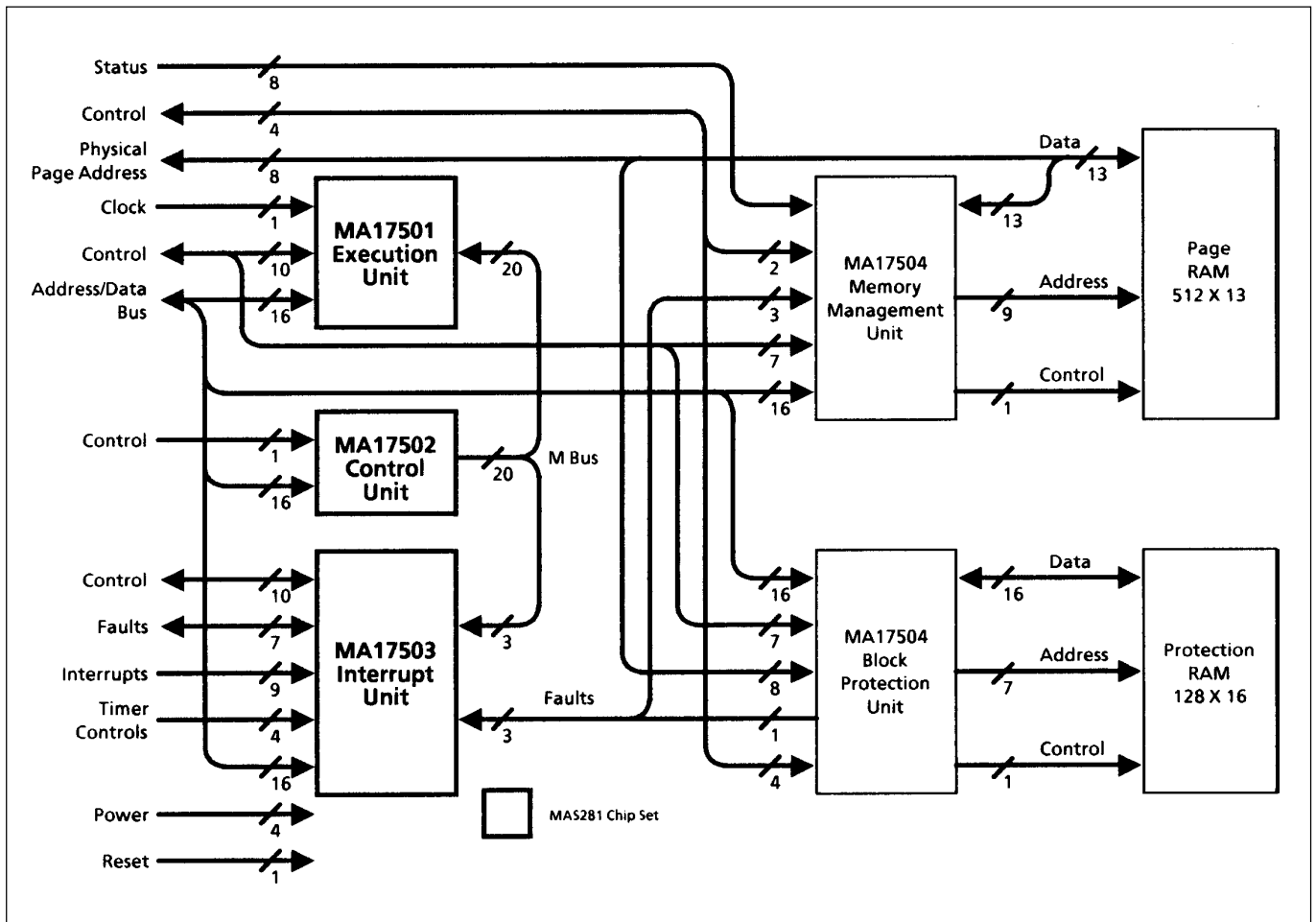

Figure 1

2.0 ARCHITECTURE

The Interrupt Unit consists of a Pending Interrupt Register, Mask Register, Interrupt Priority Encoder, Fault Register, two interval timers, two watchdog timers, DMA Control interface, and both microcode and internal I/O instruction decode logic. Details of these components are depicted in Figure 2 and are discussed below:

2.1 PENDING INTERRUPT REGISTER

The Pending Interrupt Register (PI) is the dedicated 16-bit register that latches all pending interrupt requests and stores them until serviced. The inputs to the PI are buffered by falling-edge detectors to prevent repeat latching of interrupt requests held low longer than required. The PI supports nine external interrupts inputs and seven chip set generated interrupts. The output of the PI is ANDed with the Mask Register to create the interrupt request (IRN) signal for the MA17502 Control Unit. A one in a PI bit position indicates an interrupt is pending and the interrupt level is equal to the bit position.

2.2 MASK REGISTER

The Mask Register (MK) is the dedicated 16-bit register containing the information that filters the PI output to the Priority Encoder and the IRN generation logic. A one in a MK bit position allows the interrupt request, of the same bit position in the PI, to enter the Priority Encoder and cause IRN to drop low. PI bits 1 - 4 and 6 - 15 are maskable.

2.3 INTERRUPT PRIORITY ENCODER

The Interrupt Priority Encoder accepts the enabled, mask filtered, output of the PI and generates a four bit code designating the level of the highest priority pending interrupt. Level zero (PI bit zero) has the highest priority and level 15 (PI bit 15) the lowest. The four bit priority code is placed on the AD Bus during the microcoded interrupt handling routine.

2.4 FAULT REGISTER

The Fault Register (FT) is the dedicated 16-bit register that latches the 15 specified (fault 12 is reserved) faults. The FT supports eight external Fault inputs and three chip-set generated Faults. The output of the FT is ORed together, buffered by a falling-edge detector, and input to the PI to generate the level one interrupt. FT bits 13 - 15 are used to indicate the results of the MAS281 BIT. Once the FT has latched a fault, it can only be cleared via internal I/O command (individual fault bits cannot be cleared).

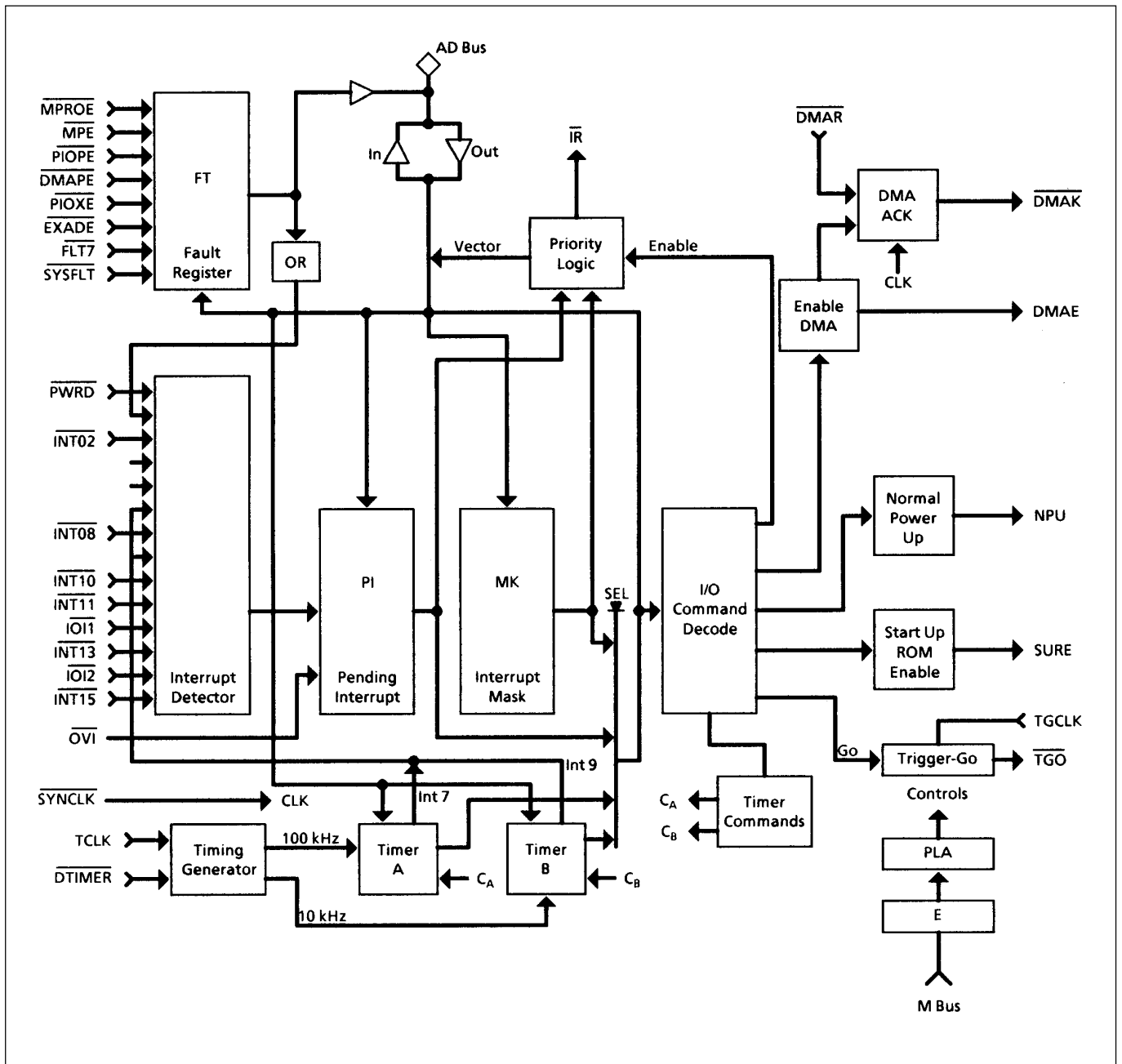

Figure 2: MA17503 Interrupt Unit Architecture

Anti-repeat logic between the FT and PI prevents latching more than a single interrupt into the PI before the user interrupt service routine has cleared the FT. The microcoded interrupt service routine reads the interrupt priority vector from the Interrupt Unit and clears the serviced interrupt from the PI. At this point the PI is ready to latch another interrupt into this bit. When this microcoded service routine acts on a level 1 interrupt, it clears the PI bit 1, but the FT maintains the interrupting fault bit(s). Therefore, a level 1 interrupt would be latched again if there were no anti-repeat logic to prevent a never ending loop of interrupts from occurring.

Interrupts are serviced at the end of the currently executing instruction if not masked and if interrupts are enabled. System software servicing level 1 interrupts must clear the FT via the RCFR internal I/O command at some point in the routine to allow subsequent faults to latch a level 1 interrupt request. A non-destructive read of the FT is provided by the internal I/O command RFR, but this command should be used carefully.

2.5 INTERVAL TIMERS

The Interrupt Unit contains both MIL-STD-1750A 16-bit interval timers, A and B. The TCLK input is synchronized with SYNCLKN and increments Timer A once a TCLK period. Timer B is incremented by the synchronized TCLK divided by 10. Timer A overflow sets PI bit 7 and Timer B overflow sets PI bit 9. The timers are controlled via the I/O command decode logic, or they can be disabled via the DTIMERN input.

2.6 WATCHDOG TIMERS

The Interrupt Unit contains two watchdog timers, Trigger-Go and Bus Fault. The Bus Fault timer assures timely completion of all AD Bus cycles by terminating bus cycles over two TCLK (maximum, minimum one TCLK period) periods in duration. This function is automatic, but can be disabled by DTON low. FT bit 5 or 8 is set for terminated I/O transfers or memory transfers, respectively, when the Bus Fault timer expires.

The Trigger-Go timer is an autonomous 16-bit ripple counter incremented by TGCLK. Upon power-up, the Trigger-Go timer begins to count. The GO I/O command resets the timer, thus preventing it from overflowing and causing TGON to drop low. The DTIMERN input prevents the Trigger-Go timer from incrementing.

2.7 DMA CONTROL INTERFACE

The DMA control interface logic is contained in the Interrupt Unit. The interface is composed of the three signals: DMAE, DMARN, and DMAKN. If the interface is enabled, an internal I/O command raises DMAE high to indicate the MAS281's readiness to accept DMA transfer requests (DMARN low). A subsequent low on DMARN causes the IU to respond with DMAKN low. DMAKN low halts the processor and places all AD Bus and bus control lines in the high-impedance state. Control is returned to the MAS281 when DMARN is pulled high again. DTIMERN is the user available way to disable the DMA interface.

2.8 INTERNAL I/O COMMAND DECODE LOGIC

The Interrupt Unit implements the 26 MIL-STD-1750A specified I/O command functions listed in Table 2. The IU also decodes an additional 386 commands that are implemented in the MMU(BPU) and the two Status Word XIO commands that are handled in microcode for AD Bus control. The IU continually monitors AD Bus traffic. When M/ION is low, the IU latches the information present on the AD Bus during the address portion of the bus cycle. This information is subsequently decoded and creates the appropriate control signals to perform the I/O command function.

2.9 MICROCODE DECODE LOGIC

The microcode decode logic can be split into command and control functions. Microcode instruction bits 4, 5 and 6 are decoded as commands for the FT, the interrupt interface, the DMA interface, and the discrete output signal, NPU. The microcode command interface is enabled when INTREN is pulled low and is disabled during DMA and the Hold state. Microcode bits 5 and 6 provide control of DDN during memory read and write cycles, and external I/O cycles.

Operation	Command Code (Hex)	Mnemonic
Output		
Set Fault Register	0401	SFR
Set Interrupt Mask	2000	SMK
Clear Interrupt Request	2001	CLIR
Enable Interrupts	2002	ENBL
Disable Interrupts	2003	DSBL
Reset Pending Interrupt	2004	RPI
Set Pending Interrupt Register	2005	SPI
Reset Normal Power Up Discrete	200A	RNS
Write Status Word	200E	WSW
Enable Start Up ROM	4004	ESUR
Disable Start up ROM	4005	DSUR
Direct Memory Access Enable	4006	DMAE
Direct Memory Access Disable	4007	DMAD
Timer A Start	4008	TAS
Timer A Halt	4009	TAH
Output Timer A	400A	OTA
Reset Trigger-Go	400B	GO
Timer B Start	400C	TBS
Timer B Halt	400D	TBH
Output Timer B	400E	OTB
Input		
Read Configuration Word	8400	RCW
Read Fault Register Without Clear	8401	RFR
Read Interrupt Mask	A000	RMK
Read Pending Interrupt Register	A004	RPIR
Read Status Word	A00E	RSW
Read and Clear Fault Register	A00F	RCFR
Input Timer A	C00A	ITA
Input Timer B	C00E	ITB

3.0 INTERFACE SIGNALS

All signals comply with the voltage levels of Table 1. In addition, each of these functions is provided with Electrostatic Discharge (ESD) protection diodes. All unused inputs must be held to their inactive state via a connection to VDD or GND.

Throughout this data sheet, active low signals are denoted by either a bar over the signal name or by following the name with an "N" suffix (e.g., DMAKN). Referenced signals that are not found on the MA17503 are preceded by the originating chip's functional acronym in parentheses (e.g., (EU)OSC).

Following is a description of each pin function grouped according to functional interface. The function name is presented first, followed by its acronym, its type, and its description. Function type is either input, output, high impedance (Hi-z), or a combination thereof. Timing characteristics of each of the functions described is provided in Section 5.0.

3.1 POWER INTERFACE

The power interface consists of one 5V VDD connection and one GND connection.

3.2 CLOCKS

The clock interface, discussed below, provides synchronization for Interrupt Unit operations and the clock inputs for the interval and watchdog timers.

3.2.1 Synchronisation Clock (SYNCLKN)

Input. The MA17501 Execution Unit (EU) generates the SYNCLKN signal for the Interrupt Unit. The Interrupt Unit uses this signal to synchronise system inputs (e.g., interrupts and faults) to the MAS281 machine cycle and to control all other internal functions.

3.2.2 Timer Clock (TCLK)

Input. TCLK is a 100 KHz, user provided clock signal that drives the interval timers A and B, and the Bus Fault timer. TCLK is synchronised to the MAS281 machine cycle, via SYNCLKN, before being sent to the interval timers. This allows the IU to implement the Internal I/O Commands associated with timer operation.

The synchronised version of TCLK drives interval timer A, clocking it once every 10 microseconds. The synchronised TCLK is divided by 10 to provide a 10 KHz clock for driving interval timer B, clocking it once every 100 microseconds.

The unsynchronised TCLK is used to increment the Bus Fault watchdog timer. When DSN drops low, the Bus Fault timer is enabled to count and expires after two TCLK high-to-low transitions.

3.2.3 Trigger-Go Clock (TGCLK)

Input. This user provided clock drives the autonomous on-chip system watchdog timer. The Trigger-Go timer is incremented by the high-to-low transition of TGCLK.

3.3 BUSES

Following is a discussion of the two communication buses connecting the Interrupt Unit to the rest of the three chip set. The AD Bus transfers 16-bit data and commands, while the M Bus communicates microcode control data.

3.3.1 Address/Data Bus (AD Bus)

Input/Output/Hi-z. These signals comprise the multiplexed address and data bus. During internal bus operations, the AD Bus accommodates the transfer of Internal I/O commands and data from the MA17501 Execution Unit to the Interrupt Unit. It also accommodates the transfer of data from the Interrupt Unit to the Execution Unit in response to internal I/O commands. AD00 is the most significant bit position and AD15 is the least significant bit position of both the 16-bit data and 16-bit command. A high on this bus corresponds to a logic 1 and a low corresponds to a logic 0.

Commands on the AD Bus are passed through transparent latches during the low state of input/output SYNCLKN cycles and are latched at the low-to-high transition of SYNCLKN. Data on the AD Bus, is either clocked into the IU by the high-to-low transition of SYNCLKN or placed there by the IU during the low portion of SYNCLKN.

3.3.2 Microcode Bus Bits 4, 5 and 6 (M04, 05 & 06)

Inputs. M04, M05, M06 are bits 4, 5 and 6 of the 20-bit Microcode Bus and are coded in the 40-bit microcode instruction as bits 4, 5 and 6. These bits are latched into the IU at the SYNCLKN high-to-low transition and are decoded for commanding the Fault Register, the DMA interface, the NPU discrete, and for providing the 4-bit priority encoded interrupt vector to the EU. IU microcode command cycles are extended to six (EU)OSC cycles by INTREN low. Microcode bits 5 and 6 provide control of DDN during memory and external I/O cycles. The microcode bus is not latched during DMA or the Hold state (DMAKN or HLDKN low).

3.4 BUS CONTROL

The following is a discussion of the signals used to control the AD Bus and M Bus. They enable the respective busses at the proper time and control system access to the MAS281 System AD Bus.

3.4.1 Data Strobe (DSN)

Input. The Interrupt Unit receives DSN from the Execution Unit. The DSN high-to-low transition starts the Bus Fault watchdog timer and during successful bus data transfers, the low-to-high transition halts and resets the Bus Fault watchdog timer. DSN is also instrumental in controlling the DDN signal during MAS281 Read/Input bus cycles.

3.4.2 Memory/Input-Output (M/ION)

Input. The Interrupt Unit receives M/ION from the Execution Unit. M/ION low enables I/O command decoding logic M/ION also selects the FT bit to set in response to a low on MPROEN and EXADEN.

3.4.3 Interrupt Unit Ready (IRDYN)

Output. The Interrupt Unit uses the IRDYN signal to cause the Execution Unit clock generation state machine to inject one wait state into Internal I/O machine cycles, thus causing the minimum five (EU)OSC period machine cycle to be extended to a six (EU)OSC period 50% duty cycle machine cycle. Internal I/O machine cycles occur during execution of the IU implemented I/O commands listed in Table 2.

3.4.4 Interrupt Unit Microcode Enable (INTREN)

Input. The Execution Unit provides INTREN to the Interrupt Unit to enable the microcode command interface. When INTREN is low, microcode instruction bits 4, 5 and 6 (latched into the IU microcode register at the SYNCLKN high-to-low transition, if HLDACKN and DMAKN are high) are decoded by the IU as commands for the FT, NPU discrete, internal DMA interface, and interrupt vectoring. INTREN low causes the EU to extend the machine cycle to six (EU)OSC periods.

3.4.5 Data Transceiver Direction (DDN)

Output. DDN is provided to control the directionality of the AD/Data Bus transceivers. DDN is high during data transfers from the MAS281 to the user system and when it is necessary to keep the transceivers from driving the MAS281 System AD Bus. DDN is low during transfers from the user system to the MAS281.

Cycles during which DDN is high include: memory writes, outputs, IU implemented Internal I/O command execution (except Read Configuration Word (RCW)), and all MA17504 MMU(BPU) implemented I/O command execution.

Cycles during which DDN is low include: memory reads (data portion), inputs (data portion), the Configuration Word read (identified by CONFWN, low), and during DMA and Hold cycles (to allow access to the MMU(BPU)).

3.4.6 Control Transceiver Direction (CDN)

Output. CDN is provided to control the directionality of the Control Bus (consists of DSN, (EU)AS, M/ION, RD/WN, and IN/OPN) transceivers. CDN is high during all MAS281 directed machine cycles. CDN drops low only when DMAKN or HLDACKN is low, indicating the MAS281 has placed the control bus signals in the high-impedance state. (It is necessary to use transceivers to buffer the control bus, if a shared MMU(BPU) architecture is used, to allow the sharing device access to the MMU(BPU) functions.)

3.5 INTERRUPT INTERFACE

The Interrupt Unit supports 16 levels of prioritised interrupts, nine of which are accessible to the user system. All user accessible interrupts are active low, are buffered with edge detectors to prevent repeat latching of the interrupt, and are latched into the Pending Interrupt register (PI) by the high-to-low transition of SYNCLKN.

The following interrupts do not have dedicated input pins on the MA17503. Level 1, Machine Error Interrupt, is driven by the ORed bits of the Fault register (FT). Levels 7 and 9 are driven by the overflow of Interval Timers A and B, respectively. The Internal I/O command, Set Pending Interrupt (SPI), is used to set interrupt levels 3, 5, and 6 (Floating-Point Overflow, Executive Call, and Floating-Point Underflow, respectively) via microcoded execution.

3.5.1 Power Down Interrupt (PWRDN)

Input. The PWRDN interrupt is the highest priority interrupt, level 0, and is latched into PI bit zero. It is nonmaskable and cannot be disabled.

3.5.2 User Interrupts (INT02N,08N,10N,11N,13N & 15N)

Inputs. Each of these user definable interrupts is latched into the PI register bits 2, 8, 10, 11, 13, or 15, respectively. Level 2 is the highest priority and level 15 is the lowest. These interrupts are maskable and can be disabled.

3.5.3 I/O Registered Interrupts (1011N & 1012N)

Inputs. Each of these interrupts is latched into the PI register bits 12 and 14, respectively. Level 12 is higher than level 14. These interrupts are maskable and can be disabled.

3.5.4 Fixed-Point Overflow (OVIN)

Input. This interrupt is driven by the MA17501 Execution Unit and is latched into the PI register bit 4. The OVIN interrupt is maskable and can be disabled.

3.5.5 Interrupt Request (IRN)

Output. This signal is the logical inclusive OR of the PI bits and is used to signal the MA17502 Control Unit that an interrupt request is pending.

3.6 FAULT INTERFACE

The Interrupt Unit supports 16 registered error condition flags. Eleven of the faults are directly accessible through dedicated input pins. A low on any of these fault inputs is latched into the Fault register (FT) by the high-to-low transition of SYNCLKN. Once a fault is latched, it can only be cleared by clearing the entire FT via Internal I/O command. The latching of any fault causes the level 1 interrupt to be set. Once set and subsequently cleared by the microcoded interrupt service routine, PI bit one cannot be set again until the FT is cleared via internal I/O command. Any unused fault inputs must be pulled-up to VDD.

3.6.1 Memory Protection Error (MPROEN)

Input. A low on this input is used to inform the MAS281 that an access fault, execute or write protection violation has been detected. When the MA31751 MMU(BPU) is used with the MAS281, the MPROEN fault input is provided by the MMU(BPU). FT bit 0 is set if a MAS281 directed memory cycle caused the error and bit 1 is set if a DMA device directed memory cycle caused the error.

Setting FT bit 0 causes PIFN to drop low. This aborts the MIL-STD-1750A instruction that was executing when the error occurred and branches execution to the machine error, level 1 interrupt service routine, if the interrupt is not masked. If the interrupt is masked, execution continues with the next instruction.

FT bit 0 is not latched during DMA or the Hold state (DMAKN or HLDACKN low).

3.6.2 Memory Parity Error (MPEN)

Input. A low on this input indicates a parity error has been detected during a memory transfer. This fault is latched into FT bit 2.

3.6.3 Programmed I/O Parity Error (PIOPEN)

Input. A low on this input indicates a parity error has been detected during an external I/O transfer. This fault is latched into FT bit 3.

MA17503

3.6.4 DMA Parity Error (DMAPEN)

Input. A low on this input indicates a parity error has been detected during a DMA data transfer. This fault is latched into FT bit 4.

3.6.5 External Address Error (EXADEN)

Input. A low on this input indicates execution of an unimplemented or reserved I/O command has been attempted (M/ION low) and sets FT bit 5, or an attempt has been made to access an unimplemented memory address (M/ION high) and sets FT bit 8.

Provision for detection of these conditions has been made on the MA17503 in the form of a Bus Fault watchdog timer. If during an I/O or memory access cycle the system machine cycle completion circuitry or (EU)RDYN generation logic fails to provide the (EU)RDYN signal within the required amount of time, the Bus Fault watchdog timer will terminate the cycle by forcing IRDYN low and set the appropriate FT bit (FT5 if I/O, FT8 if memory). The minimum Bus Fault watchdog timeout period is one TCLK period, the maximum is two TCLK periods.

Setting FT bits 5 or 8 causes PIFN to drop low. This aborts the MIL-5TD-1750A instruction during which the error occurred and branches execution to the machine error, level 1, interrupt service routine, if the interrupt is not masked. If the interrupt is masked, execution continues with the next instruction.

FT bit 5 and 8 are not latched during DMA or the Hold state (DMAKN or HLDACKN low).

3.6.6 Programmed I/O Transmission Error (PIOXEN)

Input. A low on this input indicates a user defined error has occurred during an I/O transfer. This fault is latched into FT bit 6.

3.6.7 Fault #7 (FLT7N)

Input. This is a user definable (spare) fault input. A low on this input sets FT bit 7.

3.6.8 System Fault (SYSFN)

Input. A low on this input indicates a system Built-In Test error has occurred. This fault is latched into FT bits 13 and 15.

3.6.9 Illegal Address (ILLADN)

FT bits 5 and 8 are set by a low on the EXADEN input or by the Bus Fault watchdog timer overflow. FT bits 5 and 8 are not latched, and ILLADN is held high during DMA or the Hold state (DMAKN or HLDACKN low).

3.6.10 Instruction Abort (PIFN)

Output. A low on this output effects a MIL-STD-1750A instruction abort. When a SYNCLKN high-to-low transition latches FT bit 0, 5, or 8, the following SYNCLKN high-to-low transition causes PIFN to drop low and remain low for one SYNCLKN period (except during DMA and the Hold state, i.e., DMAKN or HLDACKN low).

PIFN directs the MA17502 Control Unit to branch microcode execution to the interrupt vectoring routine for level 1 interrupt servicing. If the level 1 interrupt is masked, execution will resume with the next MIL-STD1750A instruction.

PIFN causes the MA17501 Execution Unit to hold DSN and (EU)AS in their inactive state during the transition from error indication to the beginning of the interrupt servicing routine.

3.7 DMA INTERFACE

The DMA Interface consists of the necessary handshake signals required to effect transfer of control from the MAS281 to a DMA controller and back again.

3.7.1 DMA Transfer Enable (DMAE)

Output. When this output is raised high via execution of the Internal I/O command DMAE, direct memory access requests will be acknowledged by the MAS281. If DMAE is low, direct memory access requests will not be acknowledged by the MAS281.

3.7.2 DMA Transfer Request (DMARN)

Input. A DMA controller pulls this input low to request control of the AD Bus and bus control signals for DMA transfers. DMARN is held low by the DMA controller for the duration of the DMA transfer, and the low-to-high transition indicates the DMA controller is finished using the AD Bus.

3.7.3 DMA Transfer Request Acknowledge (DMAKN)

Output. The Interrupt Unit responds to a low on DMARN, if DMAE is high, by dropping DMAKN low at the SYNCLKN high-to-low transition.

3.8 INTER-CHIP CONTROL

The Inter-Chip Control signals are used to halt the processor (the three-chip set) during the DMA and HOLD cycles and during microcode testing.

3.8.1 Processor Pause (PAUSEN)

Output. This output is low during DMA operations (DMAKN low). PAUSEN is used by the Interrupt Unit to reset and disable the Bus Fault Timeout circuitry. PAUSEN is also used by the MA17501 Execution Unit clock generation circuitry to produce an internal disable signal. This internal disable signal holds CLKPCN and SYSCCLK1N low and CLK02N high, which halts processing, and places the DSN, AS, IN/OPN, RD/WN, and M/ION output buffers, and the AD bus I/O buffers in the high impedance state, and drop DDN and CDN low to allow DMA controller access to the MMU(BPU) in shared MMU(BPU) systems.

3.8.2 Hold Acknowledge (HLDACKN)

Input. HLDACKN resets and disables the Bus Fault Timeout circuitry, causes DDN and CDN to be brought low, and prevents latching of microcode commands and decoding. The Execution Unit responds to a Hold state request (execution of BPT, or a low on HOLDN) by pulling HLDACKN low.

3.8.3 Microcode Stop (MSTOPN)

Input. MSTOPN allows microcode to be single-stepped during testing by GEC Plessey Semiconductors and should be pulled up to VDD in customer applications.

3.9 TIMER CONTROL

These Timer Control inputs allow external control of Timers A and B, the Trigger-Go Counter, and the Bus Fault Timeout circuitry.

3.9.1 Disable Timers (DTIMERN)

Input. A low to this input disables Timers A and B and the Trigger-Go counter, and also disables DMA access by forcing DMAE low and DMAKN high. Raising DTIMERN high causes Timers A and B and the Trigger-Go counter to resume counting where they were stopped, and also allows normal DMA operations.

3.9.2 Disable Bus-Fault Timeout (DTON)

Input. A low to this input will reset and disable the Busfault timeout circuitry.

3.10 DISCRETES

Four discrete outputs are provided for system use, all of which are enabled or disabled or both via internal I/O commands.

3.10.1 Trigger-Go Timer Overflow (TGON)

Output. This output drops low whenever the Trigger-Go counter overflows (rolls over to 0000). It returns high when the Trigger-Go counter is reset by software using the GO internal I/O command.

3.10.2 Normal Power-Up Indicator (NPU)

Output. This output is brought low via internal I/O command during module initialization as the first step of BIT. If BIT is completed successfully, NPU is raised high via microcode, and remains high until reset by software via the RNS internal I/O command.

START-UP ROM ENABLE (SURE)

Output. This output is used to enable an externally implemented Start-Up ROM. SURE is brought high via the execution of the ESUR internal I/O command (done by microcode during initialization or by software), and remains high until it is reset by software by using the DSUR internal I/O command. While SURE is high, all memory reads shall access main memory. This feature is utilized via the MOV instruction to effect a non-volatile memory program transfer to faster program execution RAM.

CONFIGURATION WORD ENABLE (CONFWN)

Output. This output is brought low during the data portion of an RCW (Read Configuration Word) internal I/O operation. It is used as an output enable strobe for the externally implemented Configuration Register. Because RCW is an internal I/O command, the read cycle is a fixed six (EU)OSC cycles and is terminated by IRDYN low. RDYN must not be asserted during execution of this command.

4.0 OPERATING MODES

The following discussions detail the MAS281 chip set operating modes from the perspective of the Interrupt Unit. The MAS281 operating modes involving the MA17503 are: (1) initialization, (2) instruction execution, (3) interrupt servicing, (4) fault servicing, (5) DMA support, (6) Hold support, and (7) timer operations.

4.1 INITIALISATION

A microcoded initialisation sequence is executed by the chip set in response to a hardware reset. This routine, as applicable to the Interrupt Unit, disables and masks interrupts, zeroes the Fault register, performs the MAS281 Integrated Built-In Test (BIT), raises the Start-Up ROM enable discrete (SURE), clears and starts timers A and B, resets the Trigger-Go counter, and disables DMA access. The resulting initialised state of the MA17503 is listed in Table 3.

The microcoded BIT exercises all legal microinstruction bit combinations and tests all internally accessible structures of the MAS281 chip set. For the Interrupt Unit this includes the MK, PI, and FT registers, Interrupt Enable/Disable, and Timers A and B. Table 4 details the tests performed by each of the five BIT routines.

If any part of BIT fails, an error code identifying the failed subroutine is loaded into FT bits 13-15, BIT is aborted with NPU left in the low state, initialization is completed, and instruction execution begins at address zero. The coding of the BIT results is shown in Table 4.

NOTE: To complete initialization and pass BIT, interrupt and fault inputs must be high for the duration of the initialization routine. In addition, timers A and B must be clocked for BIT success.

Item	Status
Fault (FT)	Zeroed
Pending Interrupt (PI)	Zeroed
Mask (MK)	Zeroed
Interrupts	Disabled
DMA Access	Disabled
Timer A	Reset and Started
Timer B	Reset and Started
Trigger-Go Timer	Reset and Started

Table 3: Interrupt Initialisation State

BIT	Test Coverage	BIT Fail Codes (FT13, 14, 15)	Cycles
1	Microcode Sequencer IB Register Control Barrel Shifter Byte Operations and Flags	100	221
2	Temporary Registers (T0 - T7) Macrocode Flags Multiply Divide	101	166
3	Interrupt Unit - MK, PI, FT Enable/Disable Interrupts	111	214
4	Status Word Control User Flags General Registers (R0 - R15)	110	154
5	Timer A Timer B	111	763
-	BIT Pass/Fail Overhead	-	26

Note: BIT pass is indicated by all zeros in FT bits 13, 14, and 15

Table 4: MAS281 BIT Summary

4.2 INSTRUCTION EXECUTION

The MAS281 chip set will begin instruction execution upon the completion of initialization. The instruction execution operations that involve the Interrupt Unit are: (1) internal CPU cycles, (2) memory transfers, and (3) input/output transfers. Instruction execution can be interrupted at the end of any individual machine cycle by a DMA request (DMARN low with DMAE high) or at the conclusion of any given instruction by an Interrupt or Hold state request.

4.2.1 Internal CPU Cycles

Microcode controlled IU functions are classified as internal CPU cycles. The IU interprets the three microcode bits, 4, 5, and 6, as a three bit instruction used for control of the FT, internal DMA interface, NPU discrete, and the interrupt priority vector code. The command is latched into the IU at the SYNCLKN high-to-low transition and decoded into control signals if INTREN is low. During these machine cycles, SYNCLKN is six (EU)OSC periods long. During internal CPU cycles, DSN and M/ION are held high by the Execution Unit, causing the IU to hold DDN high. Microcode bits 4, 5, and 6 are not latched or decoded during DMA or the Hold state (DMAKN or HLDAKN low).

4.2.2 Memory Transfers

The IU takes a passive role during memory transfers, i.e., it only controls the DDN signal. Microcode bits 4, 5, and 6 are latched by the SYNCLKN high-to-low transition then bits 5 and 6 are decoded to control the DDN control signal in concert with DSN. If bits 5 and 6 are high (indicating a write), DSN is kept from affecting DDN, which remains high for the entire cycle. If either bit 5 or 6 is low, DSN is allowed to control DDN, which becomes a delayed version of DSN.

4.2.3 Input/Output Transfers

The IU monitors all AD Bus traffic and controls the DDN output as specified. During cycles where M/ION is low, the IU decodes the address/command portion (SYNCLKN high) of the machine cycle. If one of the commands listed in Table 2 is encountered, the specific action takes place at the following SYNCLKN high-to-low transition; the exceptions being "GO" and "RCW". "GO" resets the Trigger-Go Timer at the SYNCLKN low-to-high transition and "RCW" drops CONFVN low during DSN low.

The read and write status word commands ("RSW", "WSW") cause IRDYN to drop low to complete the EU/MMU(BPU) machine cycle. IU decoded I/O command cycles are six (EU)OSC periods long (except for "RCW", there are five (EU)OSC periods).

4.3 INTERRUPT SERVICING

Nine user interrupt inputs and one dedicated input (OVIN) are provided for programmed response to asynchronous system events. A low on any of these inputs will be detected at the high-to-low transition of SYNCLKN and latched into the PI register on the following SYNCLKN high-to-low transition (with the exception of INT02N which is latched into PI when INT02N is first detected). This always occurs whether interrupts are enabled or disabled, or whether specific interrupts are masked or unmasked. (Because INT02N is captured asynchronously, it is possible under rare conditions for the PI bit 2 to remain set after INT02N has been serviced, causing double servicing of the one interrupt. To prevent this, bit 2 of the PI should be cleared at the end of the user service routine).

Each of the nine user interrupt inputs is buffered by a falling-edge detector to prevent repeat latching of requests held low longer than the first SYNCLKN high-to-low transition. An interrupt request input must go back to the high state before request on that input can be detected.

Command	M04, M05, M06
Load Fault Register From AD Bus	001
Read Interrupt Priority Vector Onto AD Bus	010
Raise Normal Power-up Discrete	011
Disable I/O Control of DMA Interface	100
Enable I/O Control of DMA Interface	101

Table 5: Interrupt Unit Microcode Commands

The output of the PI register is continually ANDed with the output of the MK register (level 0 interrupt is not maskable). If interrupts are enabled, and an unmasked interrupt is pending, the Interrupt Request (IRN) output to the Control Unit is asserted. This occurs when one or more interrupts are latched and unmasked. The unmasked pending interrupts are output to the priority encoder where the highest priority pending interrupt is encoded as a 4-bit vector.

After the currently executing MIL-STD-1750A instruction is completed, the Control Unit checks the state of the IRN input. If IRN is asserted, a branch is made to the microcode interrupt service routine. During this routine, the priority encoder's 4-bit vector is read into the Execution Unit, where the vector is used to calculate the appropriate interrupt linkage and service pointers (Table 6). When the EU reads the interrupt priority vector from the IU, the interrupt being serviced is cleared from the PI. If no other interrupts are pending, this also causes the IRN signal to be deactivated.

4.4 FAULT SERVICING

Eight external fault inputs are provided to the interrupt unit. A low on any of these inputs is latched into the FT register at the high-to-low transition of SYNCLKN. The capture of one or more of these faults immediately sets pending interrupt level 1 (machine error) of the PI.

Anti-repeat logic between the FT and PI prevents latching more than a single interrupt into the PI before the user interrupt service routine has cleared the FT. The microcoded interrupt service routine reads the interrupt priority vector from the Interrupt Unit and clears the serviced interrupt from the PI. At this point the PI is ready to latch another interrupt into this bit.

When this microcoded service routine acts on a level 1 interrupt, it clears the PI bit 1, but the FT maintains the interrupting fault bit(s). Therefore, a level 1 interrupt would be latched again if there was no anti-repeat logic to prevent a never ending loop of interrupts from occurring.

Interrupts are serviced at the end of the currently executing instruction if not masked and if interrupts are enabled. System software servicing level 1 interrupts must clear the FT via the RCFR internal I/O command at some point in the routine to allow subsequent faults to latch a level 1 interrupt request. A non-destructive read of the FT is provided by the internal I/O command RFR, but this command should be used carefully.

Faults caused by a low on EXADEN, MPROEN, or Bus Fault Timer expiration (FT 0, 5, 8) require that the currently executing MIL-STD-1750A instruction be aborted. In order to accomplish this, the latching of faults 0, 5, or 8 causes the Interrupt Unit to assert the instruction abort (PIFN) output to both the Execution Unit and the Control Unit Faults 0, 5, and 8 are not latched during DMA cycles or the Hold state (CDN low).

Interrupt Number	Function	Priority ⁽¹⁾ Level	Maskable	Disability	Linkage Pointer	Service Pointer
0	Power Down	0	No	No	20	21
1	Machine Error	1	Yes	No	22	23
2	User 0	2	Yes	Yes	24	25
3	Floating Point Overflow	3	Yes	Yes	26	27
4	Fixed Point Overflow	4	Yes	Yes	28	29
5	Executive Call	5	No	No	2A	2B
6	Floating Point Underflow	6	Yes	Yes	2C	2D
7	Timer A	7	Yes	Yes	2E	2F
8	User 1	8	Yes	Yes	30	31
9	Timer B	9	Yes	Yes	32	33
10	User 2	10	Yes	Yes	34	35
11	User 3	11	Yes	Yes	36	37
12	I/O 1	12	Yes	Yes	38	39
13	User 4	13	Yes	Yes	3A	3B
14	I/O 2	14	Yes	Yes	3C	3D
15	User 5	15	Yes	Yes	3E	3F

Note: (1) Level 0 has highest priority, level 15 lowest.

Table 6: Interrupt Vector Assignments

4.5 DMA SUPPORT

DMA data transfers are performed over the system AD bus under the control of the IU DMA interface logic. The user signals that DMA requests will be honored by setting the DMAE output high via the DMAE internal I/O command. The DMA controller may request use of the AD bus by pulling DMARN low, but, unless DMAE is high, all such requests will be ignored. DMARN is acknowledged by raising DMAKN low. This occurs at the first SYNCLKN high-to-low transition after DMARN is pulled low.

When a DMA request is acknowledged (DMAKN low), DDN is dropped low to direct the system data bus transceivers to drive the local AD bus, and CDN is dropped low to disable the control signal buffers. (It is necessary to use transceivers to buffer the control bus if a shared MMU(BPU) architecture is used, to allow the sharing device access to the MMU(BPU) functions).

When the DMA controller relinquishes control of the AD bus (by raising DMARN high), DMA operations are ended by raising DMAKN high at the next SYNCLKN high-to-low transition, and DDN and CDN then resume normal operation.

4.6 HOLD SUPPORT

The Hold interface is handled by the Execution Unit, but the Hold acknowledge (HLDACKN) line is monitored by the Interrupt Unit. When HLDACKN is active, the Interrupt Unit lowers DDN and CDN, resets and disables the Bus-Fault decoding (bits 4-6). When the Hold state is terminated, DDN and CDN resume normal operation.

4.7 TIMER OPERATIONS

Interval Timers A and B, the Trigger-Go Counter and the Bus-Fault timer are all implemented in the Interrupt Unit.

4.7.1 Timers A and B

Timer A is clocked by the TCLK input (which is internally synchronised to SYNCLKN), whereas Timer B is clocked by an internally generated TCLK/10 (also internally synchronized to SYNCLKN). TCLK is required to be a 100KHz pulse train by MIL-STD-1750A. If they are allowed to overflow. Timers A and B will set level 7 and level 9 interrupt requests, respectively. Each timer can be read, loaded, started, and stopped via internal I/O commands.

External control of Timers A and B can be accomplished by asserting the DTIMERN input. When DTIMERN is low, both timers will halt and all internally decoded internal I/O commands which would change their state are disabled (asserting DTIMERN low also disables DMA accesses by driving DMAE low and DMAKN high). Raising DTIMERN high allows normal operations to resume where they left off.

4.7.2 Trigger-Go Counter

The Trigger-Go Counter is clocked by the TGCLK input. DTIMERN low disables and enables counter operations in the same way as Timers A and B. When the Trigger-Go counter overflows, the output discrete TGON drops low and remains low until the counter is reset via the "GO" internal I/O command.

4.7.3 Bus-Fault Timer

This on-chip watchdog timer is provided to monitor all bus operations to ensure timely completion. This hardware timeout circuit is enabled at the start of each memory and I/O transfer (DSN high-to-low transition), and is reset on the following SYNCLKN high-to-low transition (an external ready (RDYN) must have been received by the Execution Unit for this to occur).

If this circuit is not reset within a minimum of one TCLK period or a maximum of two TCLK periods, either bit 3 (if a memory transaction) or bit 5 (if an I/O transaction) of the FT register is set. This causes the current MIL-STD-1750A instruction to be aborted as discussed above. This feature can be disabled externally by pulling DTON low and is not available during DMA or the Hold state (DMAKN or HLDACKN low).

5.0 TIMING CHARACTERISTICS

This section provides the detailed timing specifications for the MA17503 Interrupt Unit. Figure 3 depicts the test loads used to obtain the timing data. Figures 4 through 15 depict the timing waveforms associated with various MA17503 signals. Table 7 lists values for the parameters specified in the timing waveforms. All timing values provided in Table 7 are valid over the full military temperature range (-55°C to +125°C), assume the recommended operating conditions, and are measured from 50% point to 50% point (50% of VDD supply voltage, unless otherwise specified). Crosshatching in Figures 4 through 15 indicates either a „don't care” state or indeterminate state.

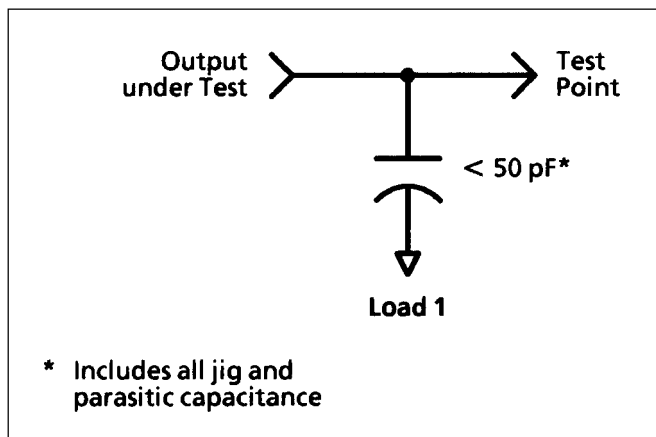

Figure 3: Test Load

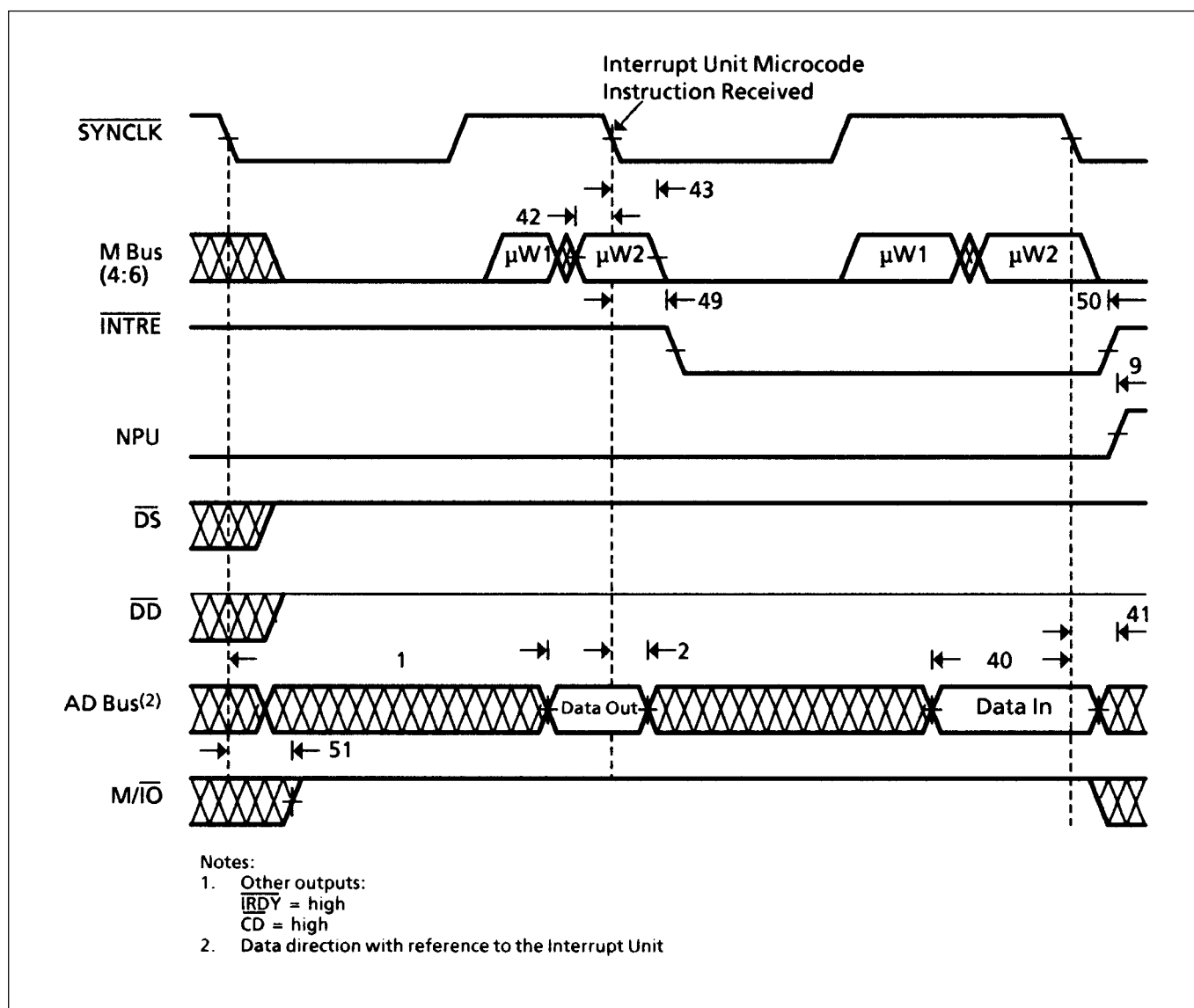

Figure 4: Microcode Operations

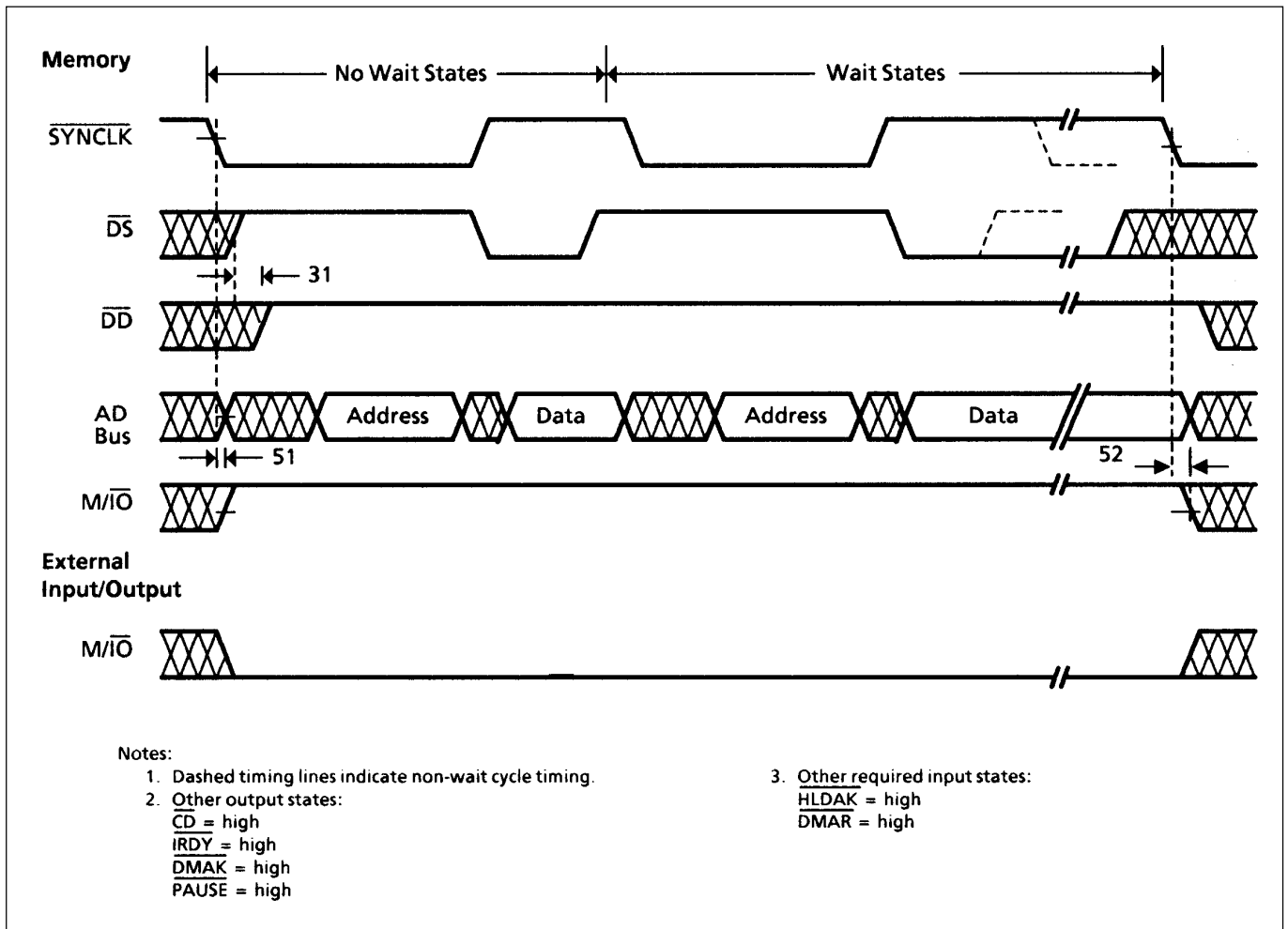

Figure 5: Write Transfer Timing

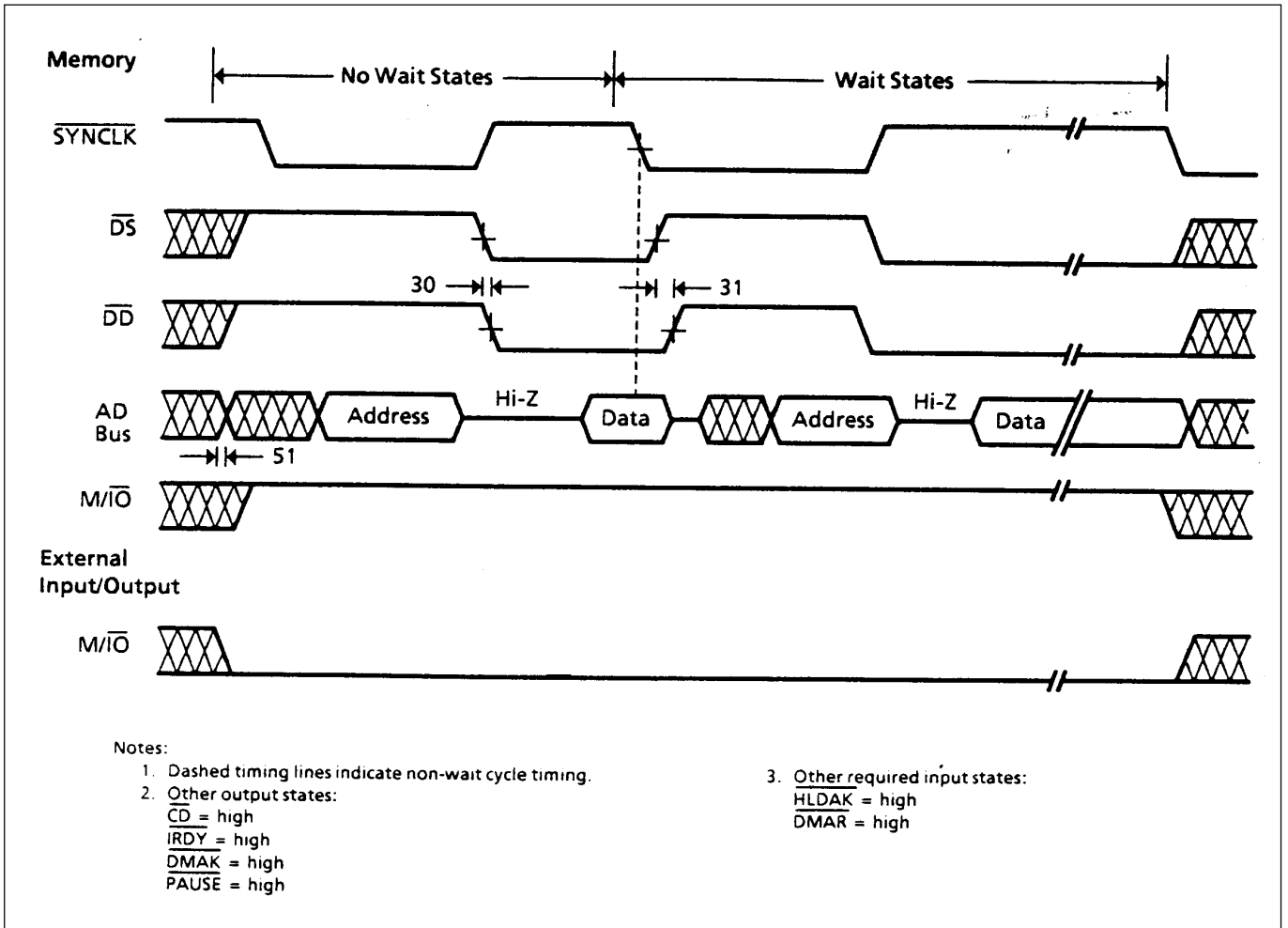

Figure 6: Read Transfer Timing

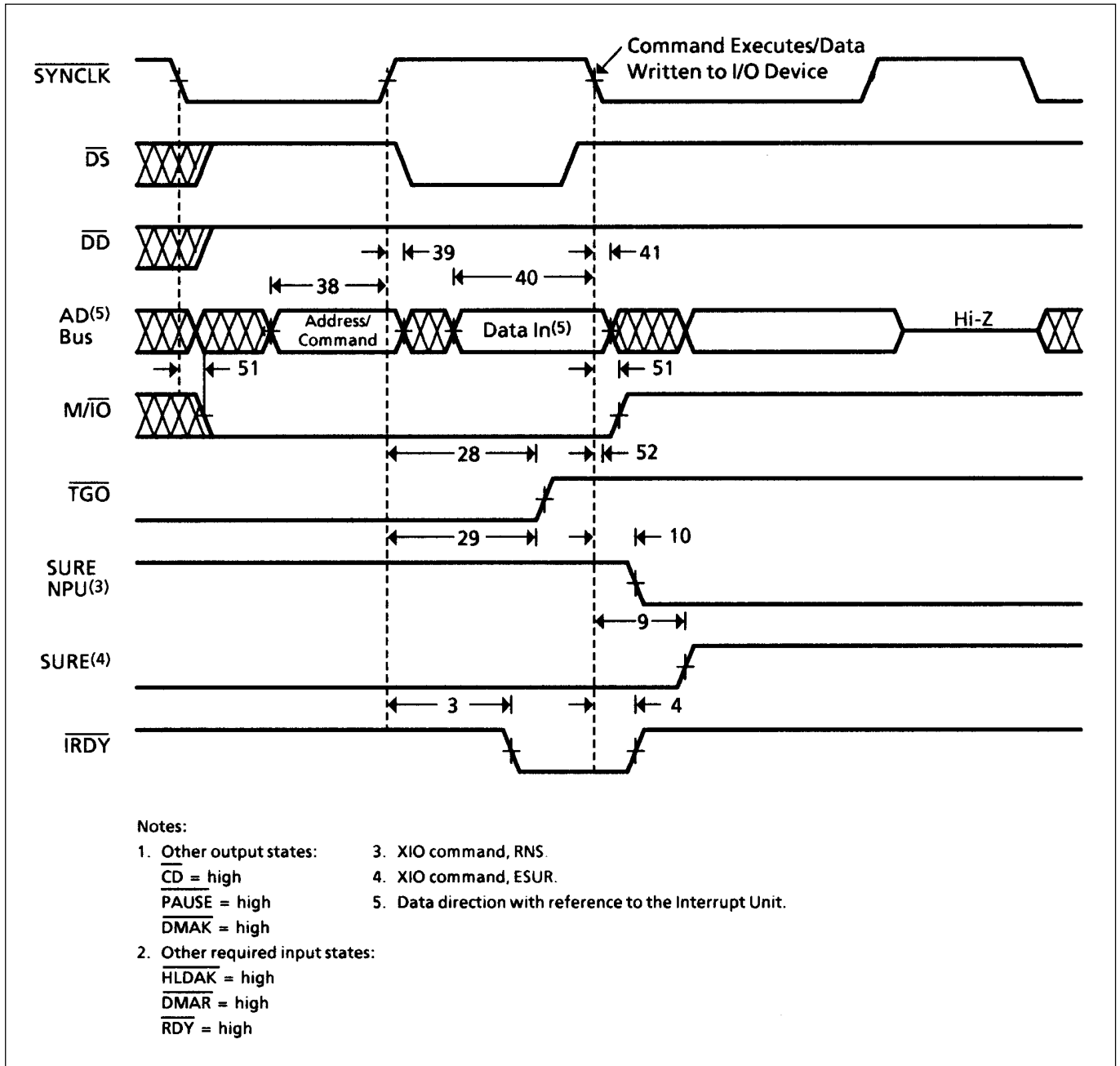

Figure 7: Internal I/O Timing - Write/Command

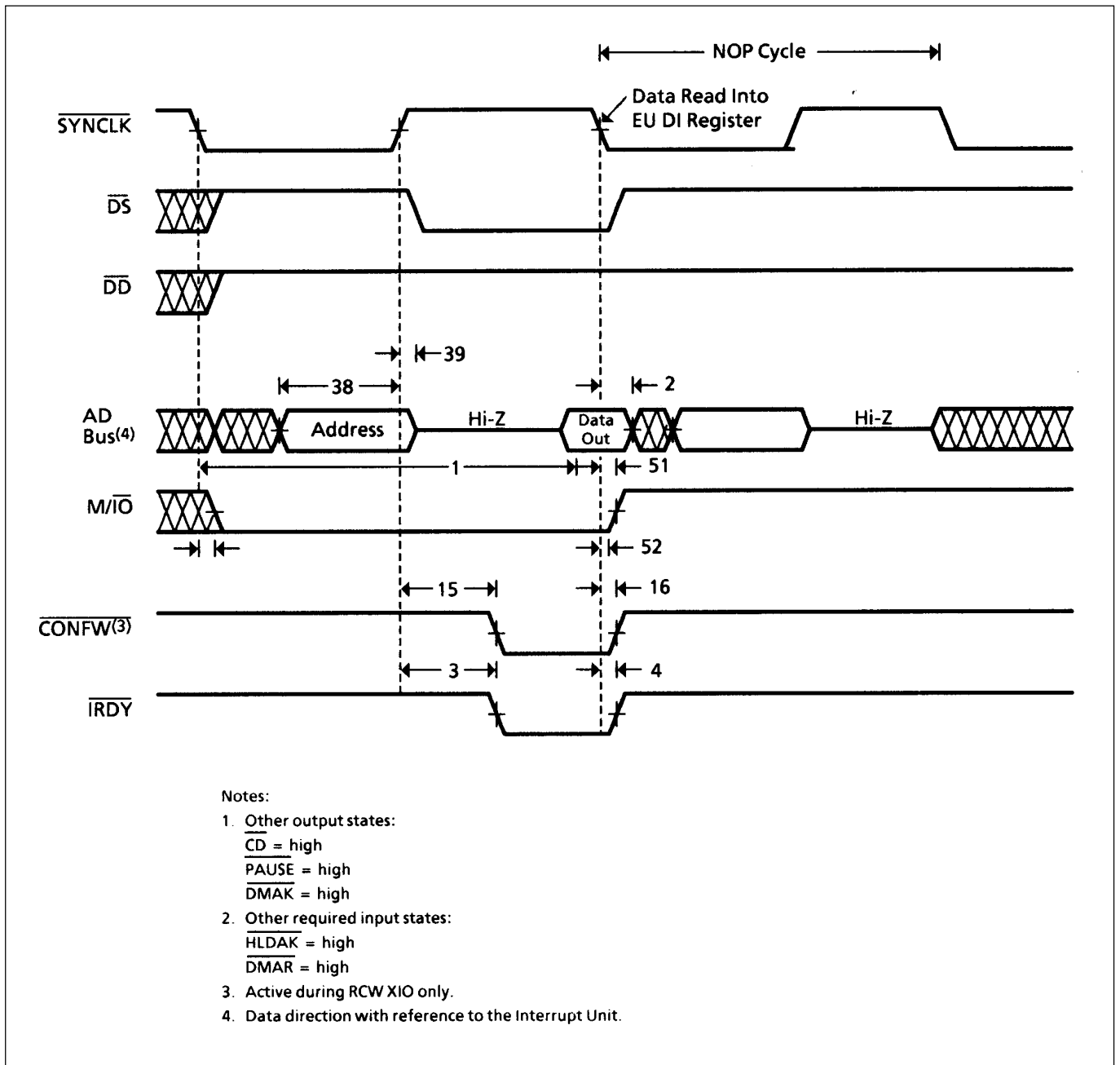

Figure 8: Internal I/O Timing - Read

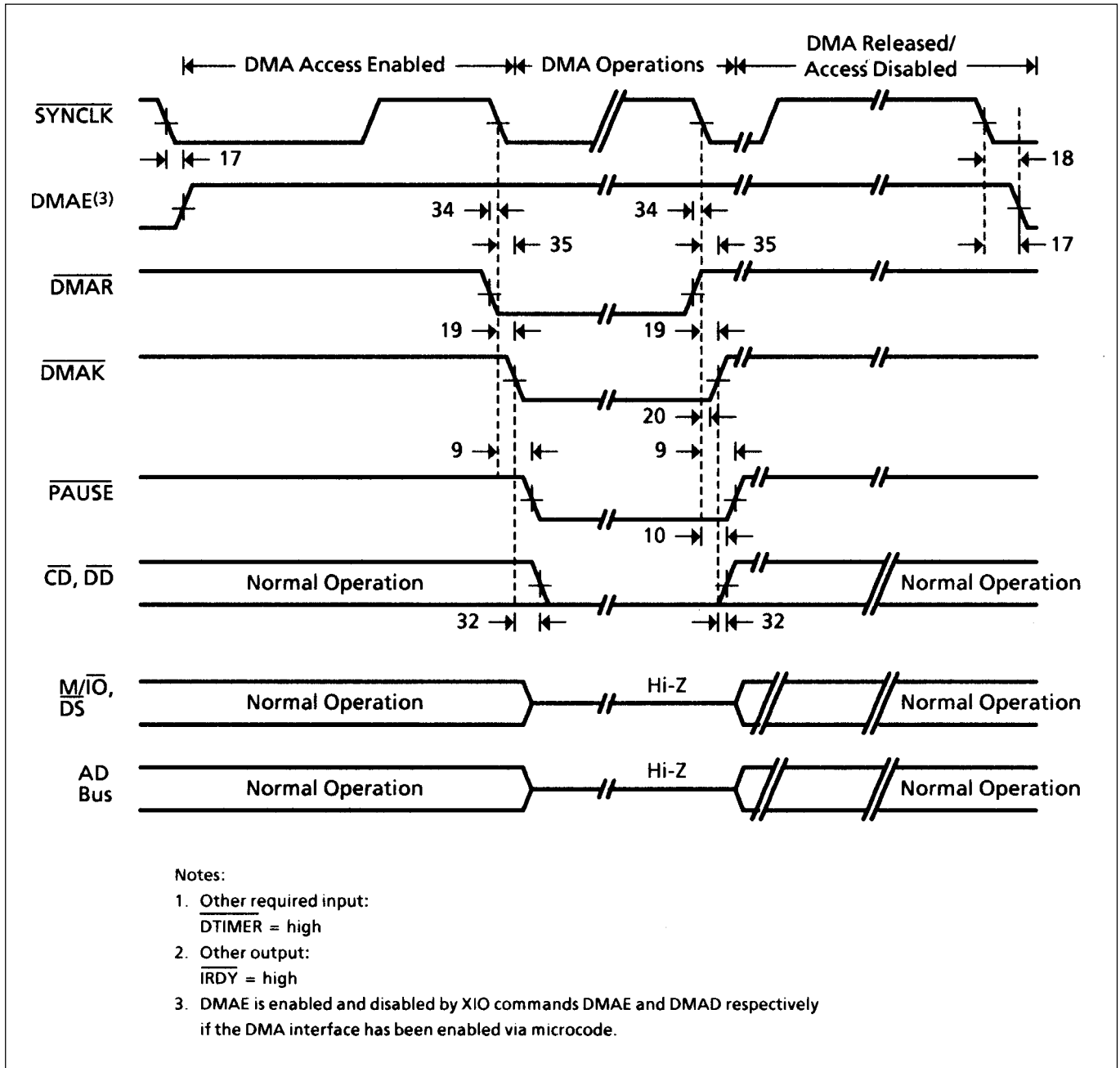

Figure 9: DMA Access/Release Timing

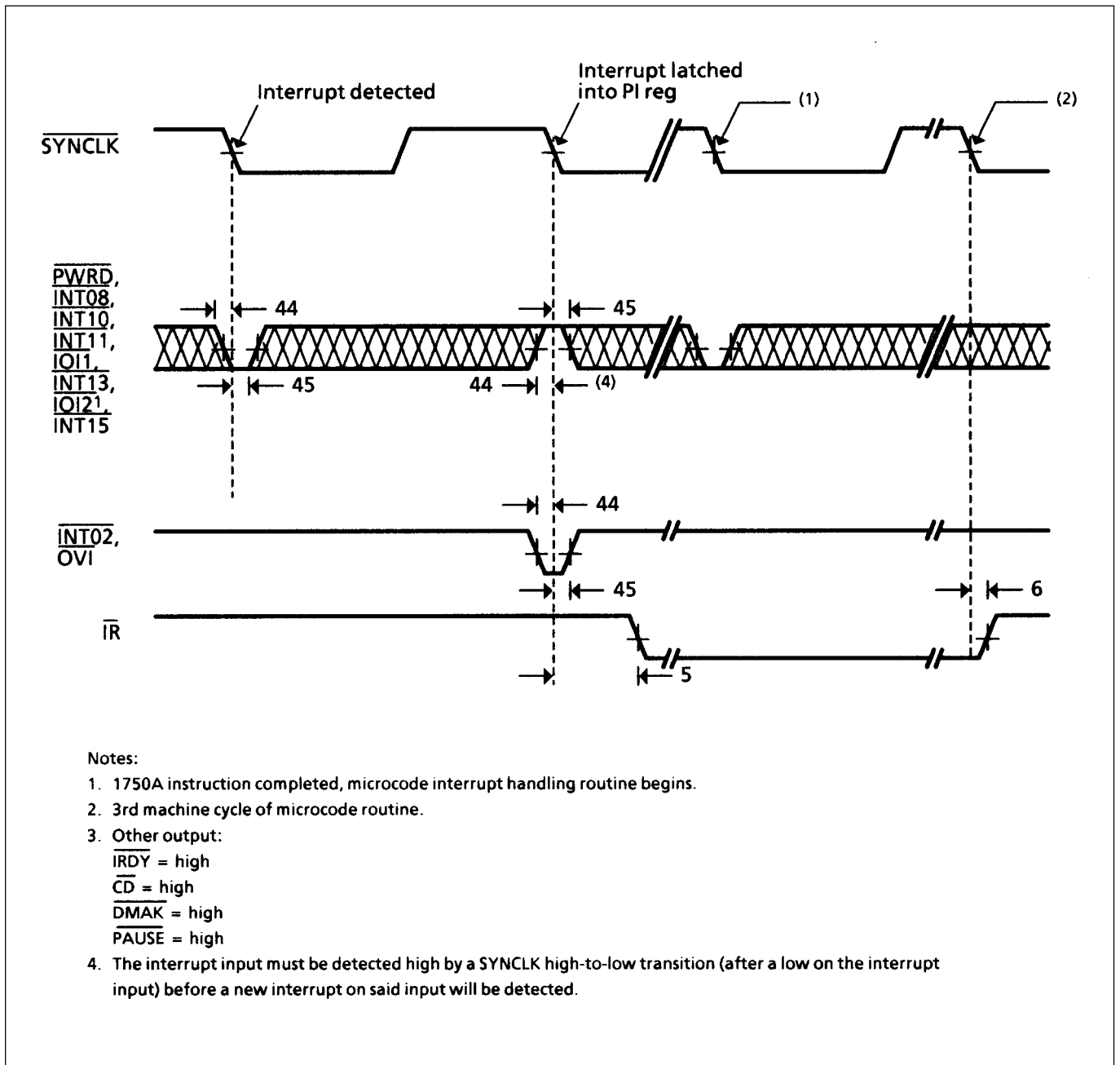

Figure 10: Interrupt Request Timing

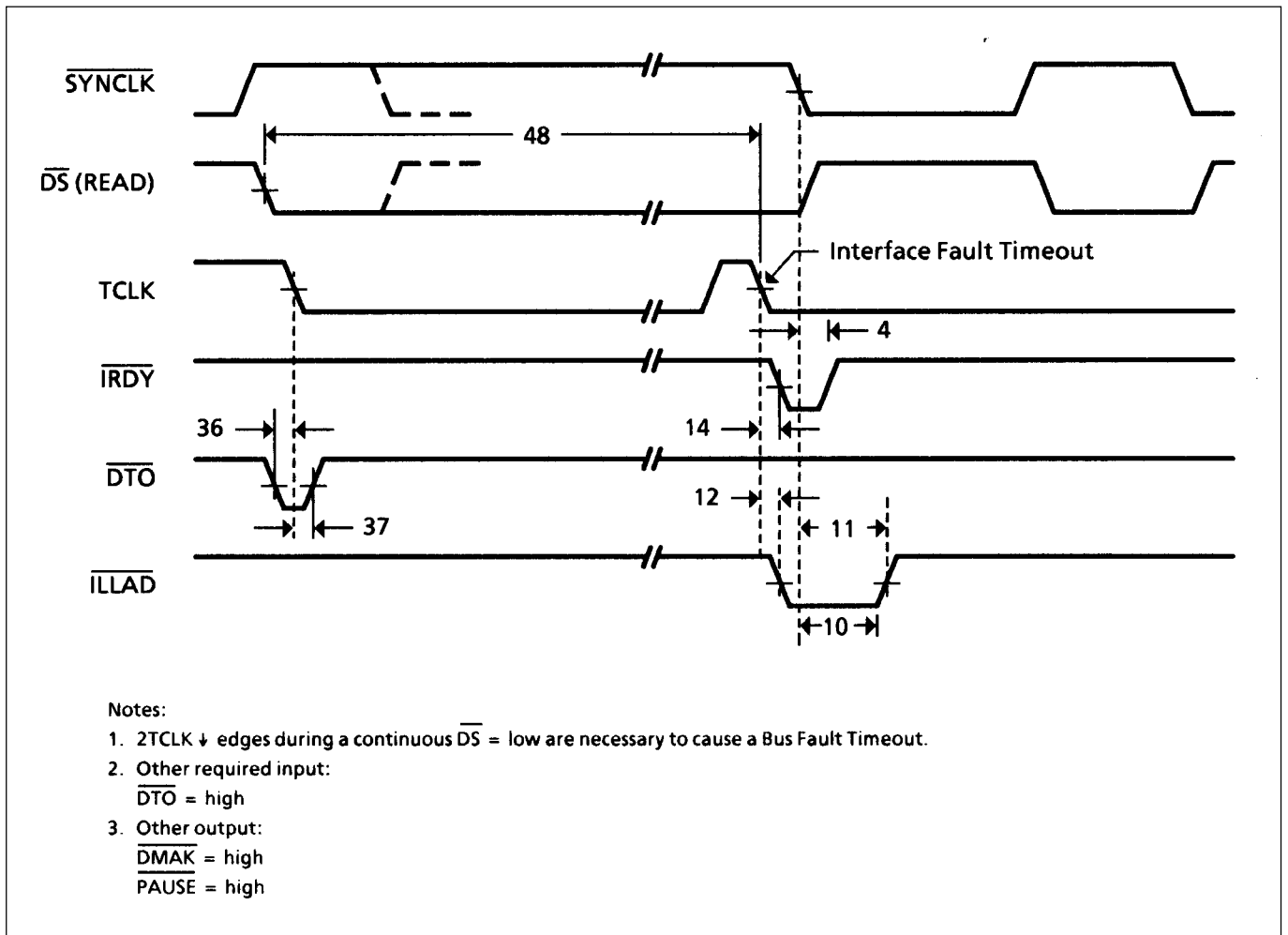

Figure 11: Bus Fault Timeout Timing

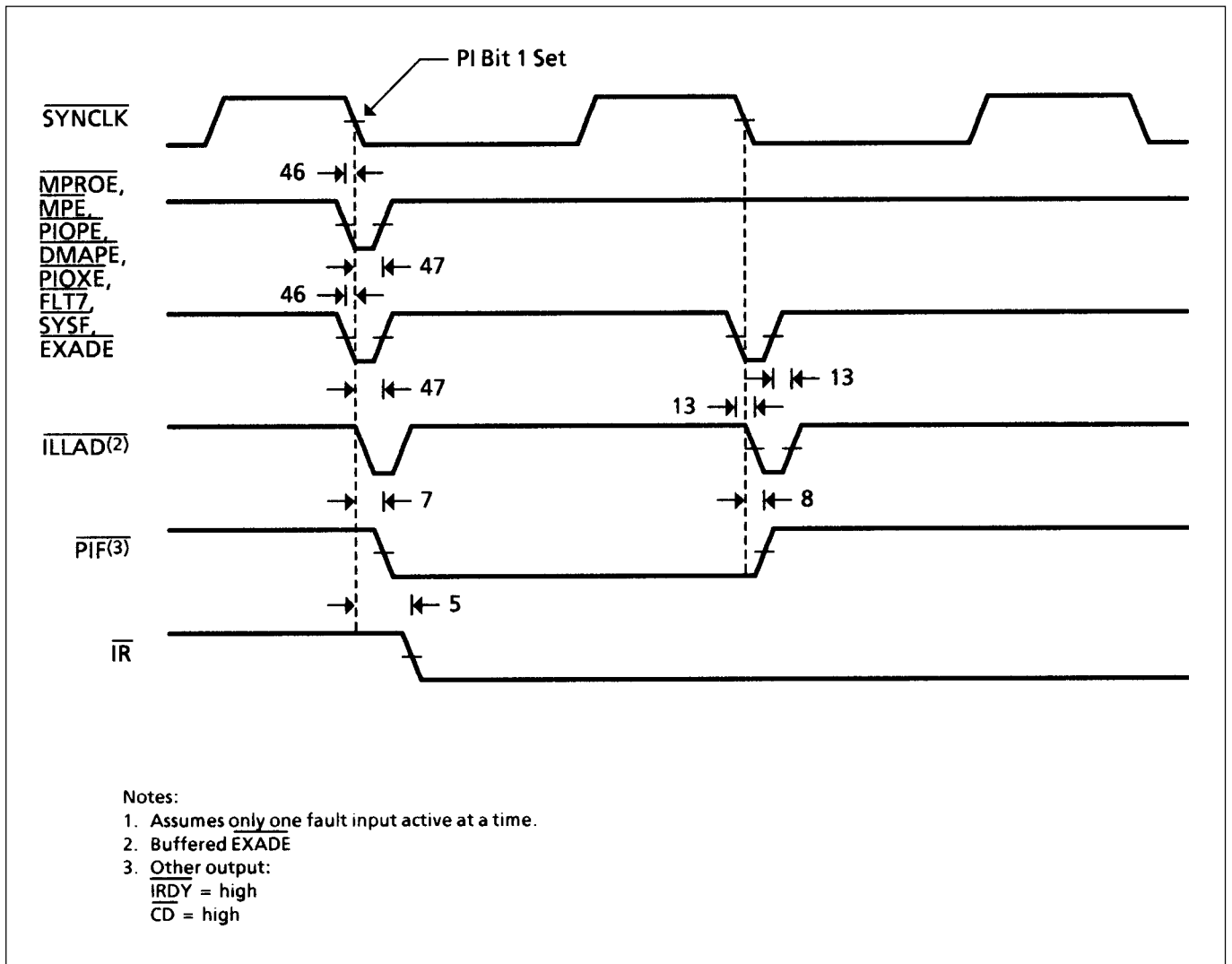

Figure 12: Fault Capture Timing

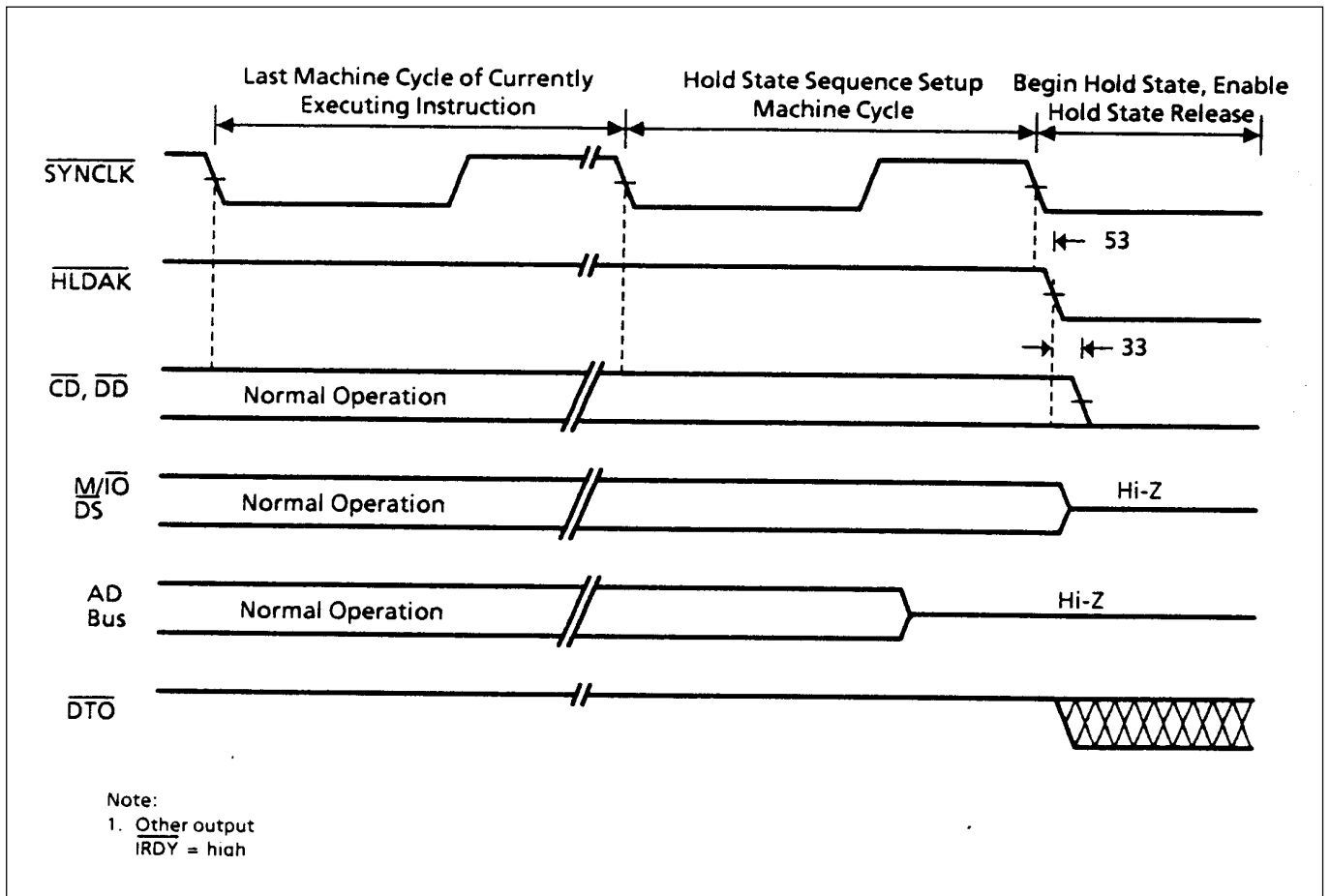

Figure 13: Hold State Generation Timing

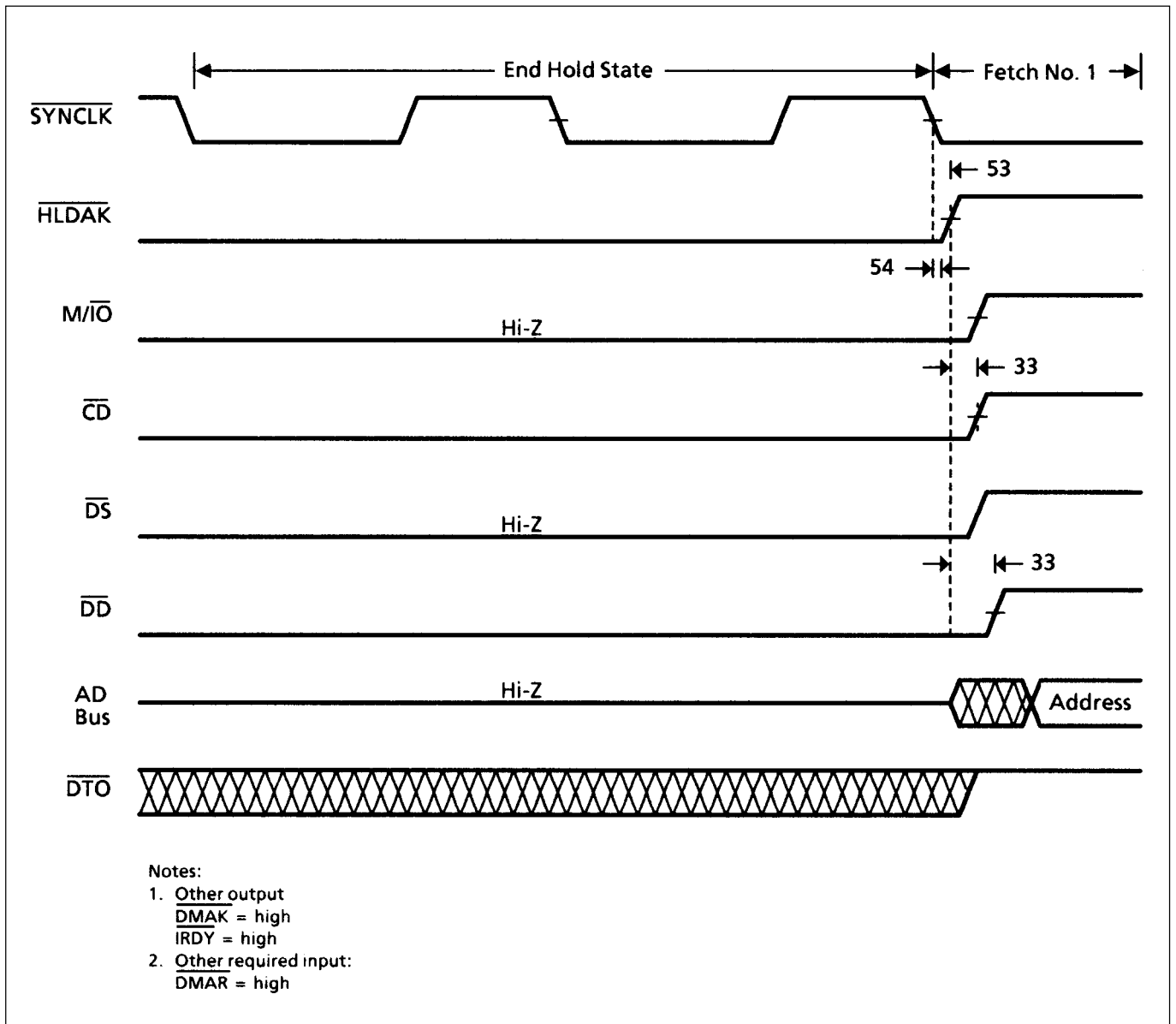

Figure 14: Hold State Termination Timing

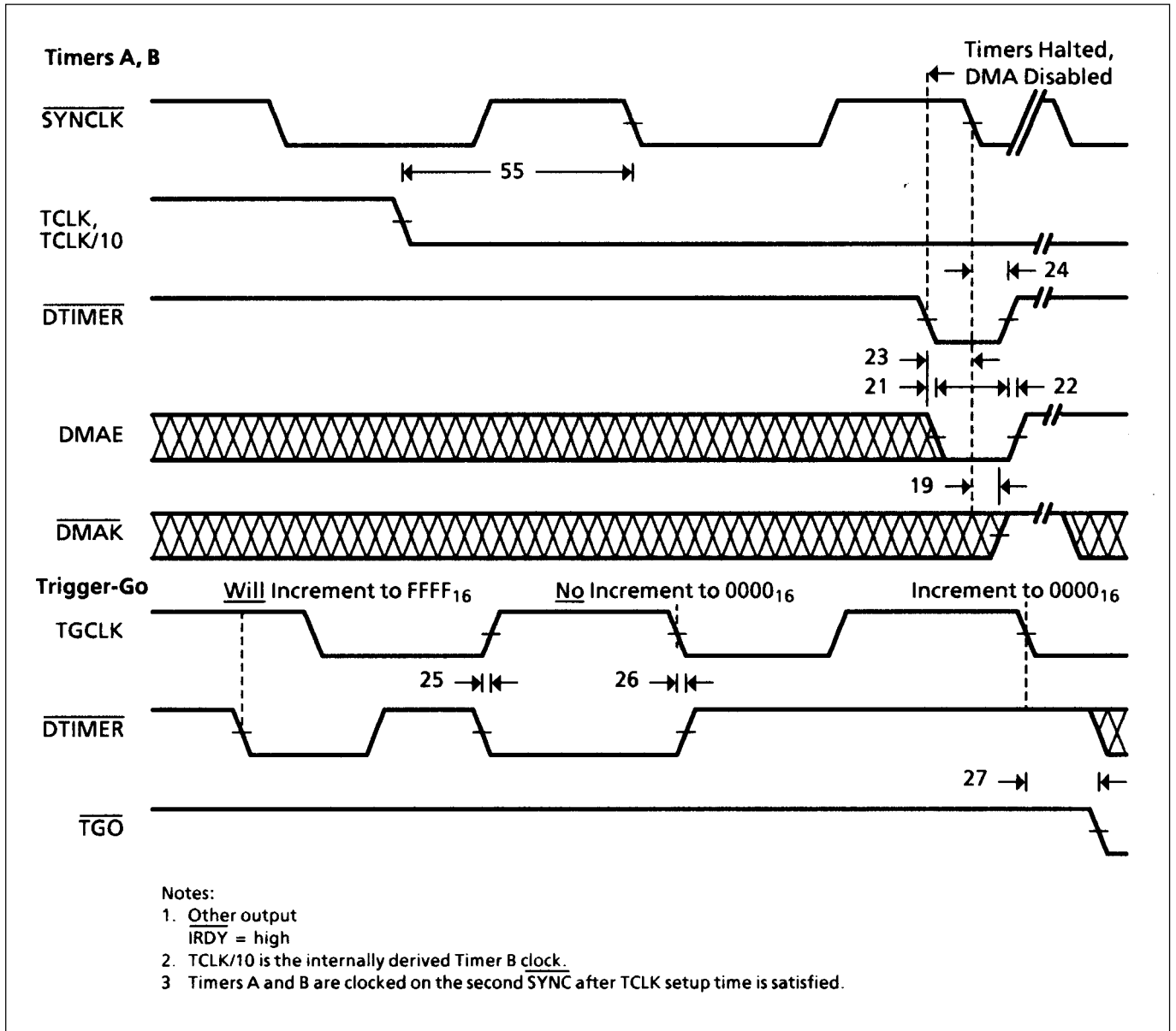

Figure 15: Timer Operations

Subgroup	Definition
1	Static characteristics specified in Table 9 at +25°C
2	Static characteristics specified in Table 9 at +125°C
3	Static characteristics specified in Table 9 at -55°C
7	Functional tests at +25°C
8a	Functional tests at +125°C
8b	Functional tests at -55°C
9	Switching characteristics specified in Table 7b at +25°C
10	Switching characteristics specified in Table 7b at +125°C
11	Switching characteristics specified in Table 7b at -55°C

Table 7a: Definition of Subgroups

No.	Parameter	Test Conditions ⁽¹⁾⁽²⁾	Min	Typ	Max ⁽³⁾	Units
1	SYNCLKN ↓ to Data Valid	Load 1	-		3r+100	ns
2	Data Valid after SYNCLKN ↓	Load 1	30		-	ns
3	SYNCLKN ↑ to IRDYN Valid	Load 1	-		40	ns
4	IRDYN Valid after SYNCLKN ↓	Load 1	10		-	ns
5	SYNCLKN ↓ to IRN Valid	Load 1	-		60	ns
6	IRN Valid after SYNCLKN ↓	Load 1	15		-	ns
7	SYNCLKN ↓ to PIFN Valid	Load 1	-		50	ns
8	PIFN Valid after SYNCLKN ↓	Load 1	15		-	ns
9	SYNCLKN ↓ to SURE, NPU, PAUSEN Valid	Load 1	-		50	ns
10	SURE, NPU, ILLADN, PAUSEN after SYNCLKN ↓	Load 1	15		-	ns
11	SYNCLKN ↓ to ILLADN ↑	Load 1	-		75	ns
12	TCLK ↓ to ILLADN ↓ (Bus Timeout)	Load 1	-		75	ns
13	EXADEN to ILLADN Valid	Load 1	-		60	ns
14	TCLK ↓ to IRDYN ↓ (Bus Timeout)	Load 1	-		50	ns
15	SYNCLKN ↑ to CONFVN Valid	Load 1	-		75	ns
16	CONFVN Valid After SYNCLKN ↓	Load 1	10		-	ns
17	SYNCLKN ↓ to DMAEN Valid	Load 1	-		75	ns
18	DMAE Valid after SYNCLKN ↓	Load 1	5		-	ns
19	SYNCLKN ↓ to DMAKN Valid	Load 1	-		50	ns
20	DMAKN Valid after SYNCLKN ↓	Load 1	5		-	ns
21	DTIMERN ↓ to DMAEN ↓	Load 1	-		60	ns
22	DTIMERN ↓ to DMAEN ↑	Load 1	-		60	ns
23	DTIMERN Setup to SYNCLKN ↓		50		-	ns
24	DTIMERN Hold after SYNCLKN ↓		10		-	ns
25	DTIMERN Setup to TGCLK ↑		30		-	ns
26	DTIMERN Hold after TGCLK ↓		12		-	ns
27	TGCLK ↓ to TGON ↓	Load 1	-		150	ns
28	SYNCLKN ↑ to TGON ↑	Load 1	-		75	ns
29	TGON Valid after SYNCLKN ↑	Load 1	15		-	ns
30	DSN ↓ to DDN ↓	Load 1	10		35	ns
31	DSN ↑ to DDN ↑	Load 1	10		35	ns
32	DMAKN to DDN, CDN Valid	Load 1	-		30	ns
33	HLDAKN to DDN, CDN Valid	Load 1	-		50	ns
34	DMARN Setup to SYNCLKN ↓		20		-	ns
35	DMARN Hold after SYNCLKN ↓		10		-	ns
36	DTON Setup to TCLK ↓		30		-	ns
37	DTON Hold after TCLK ↓		10		-	ns
38	Address/Command Setup to SYNCLKN ↑		50		-	ns
39	Address/Command Hold after SYNCLKN ↑		10		-	ns
40	Data Setup to SYNCLKN ↓		50		-	ns
41	Data Hold after SYNCLKN ↓		5		-	ns
42	Microcode Setup to SYNCLKN ↓		10		-	ns
43	Microcode Hold after SYNCLKN ↓		20		-	ns
44	Interrupts Setup to SYNCLKN ↓		20		-	ns
45	Interrupts Hold after SYNCLKN ↓		10		-	ns
46	Faults Setup to SYNCLKN ↓		20		-	ns
47	Faults Hold after SYNCLKN ↓		15		-	ns
48	Bus Fault Timeout Interval (4)		1		2	TCLK
49	INTREN Setup to SYNCLKN ↓		30		-	ns
50	INTREN Hold after SYNCLKN ↓		5		-	ns
51	M/ION Setup to SYNCLKN ↓		40		-	ns
52	M/ION Hold after SYNCLKN ↓		5		-	ns
53	HLDAKN Setup to SYNCLKN ↓		20		-	ns
54	HLDAKN Hold after SYNCLKN ↓		7		-	ns
55	TCLK Setup to SYNCLKN ↓		15		-	ns
56	TCLK Hold after SYNCLKN ↓		10		-	ns

Mil-Std-883, Method 5005, Subgroups 9, 10, 11.

(1) $T_A = +25^\circ\text{C}$, -55°C and $+125^\circ\text{C}$ tested at $V_{DD} = 4.5\text{V}$ and 5.5V .

(2) Unless otherwise noted: $V_{IL} \geq 0.9\text{V}$, $V_{IH} \leq 4.0\text{V}$ timing measured from 50% to 50% points.

(3) $r = 1\text{OSC period } 0.5r$ implies 50% OSC duty cycle.

(4) Data obtained by characterization or analysis; not routinely measured.

Table 7b: Timing Parameter Values

MA17503

6.0 ABSOLUTE MAXIMUM RATINGS

Parameter	Min	Max	Units
Supply Voltage	-0.5	7	V
Input Voltage	-0.3	$V_{DD}+0.3$	V
Current Through Any Pin	-20	+20	mA
Operating Temperature	-55	125	°C
Storage Temperature	-65	150	°C

Note: Stresses above those listed may cause permanent damage to the device. This is a stress rating only and functional operation of the device at these conditions, or at any other condition above those indicated in the operations section of this specification, is not implied. Exposure to absolute maximum rating conditions for extended periods may affect device reliability.

Table 8: Absolute Maximum Ratings

7.0 DC ELECTRICAL CHARACTERISTICS

Symbol	Parameter	Conditions	Total Dose Radiation Not Exceeding 3×10^5 Rad(Si)			Units
			Min	Typ	Max	
V_{DD}	Supply Voltage	$V_{SS} = 0$	4.5	5.0	5.5	V
V_{IHC}	CMOS Input High Voltage (Note 1)	-	$V_{DD}-1$	-	-	V
V_{ILC}	CMOS Input Low Voltage (Note 1)	-	-	-	$V_{SS}+1$	V
V_{IHT}	TTL Input High Voltage (Note 2)	-	2.0	-	-	V
V_{ILT}	TTL Input Low Voltage (Note 2)	-	-	-	0.8	V
V_{OHC}	CMOS Output High Voltage (Note 1)	$I_{OH} = -1.4mA, V_{DD} = 4.5V$	4.0	-	-	V
V_{OLC}	CMOS Output Low Voltage (Note 1)	$I_{OL} = 2mA, V_{DD} = 5.5V$	-	-	0.5	V
V_{OHT}	TTL Output High Voltage (Note 2)	$I_{OH} = -1.4mA, V_{DD} = 4.5V$	3.5	-	-	V
V_{OLT}	TTL Output Low Voltage (Note 2)	$I_{OL} = 2mA, V_{DD} = 5.5V$	-	-	0.4	V
I_L	Input Leakage Current (Note 3)	$V_{DD} = 5.5V, V_{IN} = 0V$ or $5.5V$	-	-	± 10	μA
I_{OZ}	Output Leakage Current (Note 3)	$V_{DD} = 5.5V, V_O = 0V$ or $5.5V$	-	-	± 50	μA
I_{DDOP}	Operating Supply Current	$V_{DD} = 5.5V,$ $SYNCLKN = 4MHz$	-	5	14	mA
I_{DDST}	Static Supply Current	$V_{DD} = 5.5V,$ $SYNCLKN = 0MHz$	-	3	10	mA

Mil-Std-883, Method 5005, Subgroup 1, 2, 3.

Notes: 1. The following signals are CMOS compatible:

- a) CMOS inputs: INTREN, Microcode Bus, (M04, M05, M06), HLDACKN and SYNCLK.
- b) CMOS outputs: PIFN, IRN and IRDYN.

2. The following signals are TTL compatible:

- a) DTIMERN, TGCLK, MPROEN, DMAPEN, EXADEN, PIOXEN, FLT7N, SYSFN, OVIN, PWRDN, INT02N, INT08N, INT10N, INT11N, INT12N/IO11N, INT13N, INT14N/IO12N, INT15N, DTON, DSN, M/ION, DMARN, TCLK and MSTOPN.
- b) TTL outputs: SURE, NPU, DDN, TGON, CDN, PAUSED, ILLADN, CONFIG, DMAKN and DMAE.
- c) TTL I/O signal: Address/Data Bus (AD00-AD15).

3. Worst case at $T_A = +125^\circ C$, guaranteed but not tested at $T_A = -55^\circ C$.

Table 9: DC Electrical Characteristics

8.0 PACKAGING INFORMATION

Ref	Millimetres			Inches		
	Min.	Nom.	Max.	Min.	Nom.	Max.
A	-	-	5.715	-	-	0.225
A1	0.38	-	1.53	0.015	-	0.060
b	0.35	-	0.508	0.014	-	0.020
c	0.229	-	0.36	0.009	-	0.014
D	-	-	82.04	-	-	3.230
e	-	2.54 Typ.	-	-	0.100 Typ.	-
e1	-	22.86 Typ.	-	-	0.900 Typ.	-
H	4.71	-	5.38	0.185	-	0.212
Me	-	-	23.4	-	-	0.920
Z	-	-	1.27	-	-	0.050
W	-	-	1.53	-	-	0.060

XG413

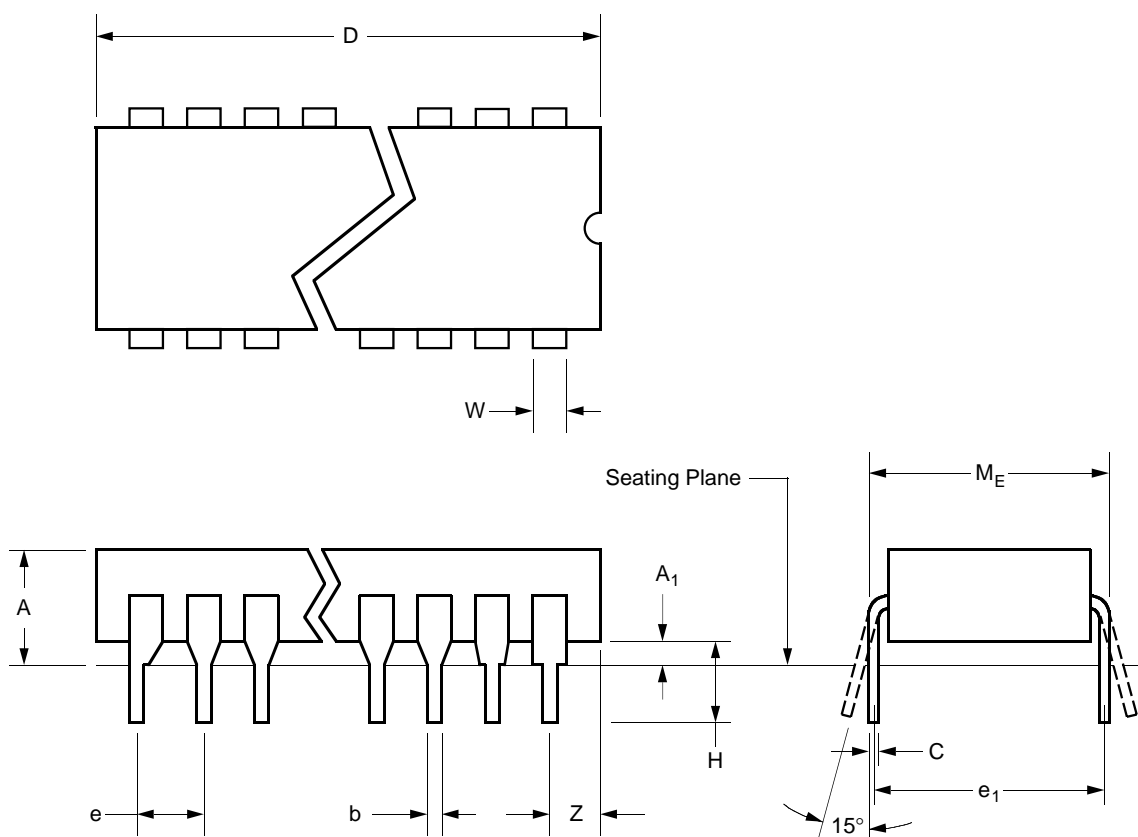

Figure 16a: 64-Pin Ceramic Sidebrazed DIP - Package Style C

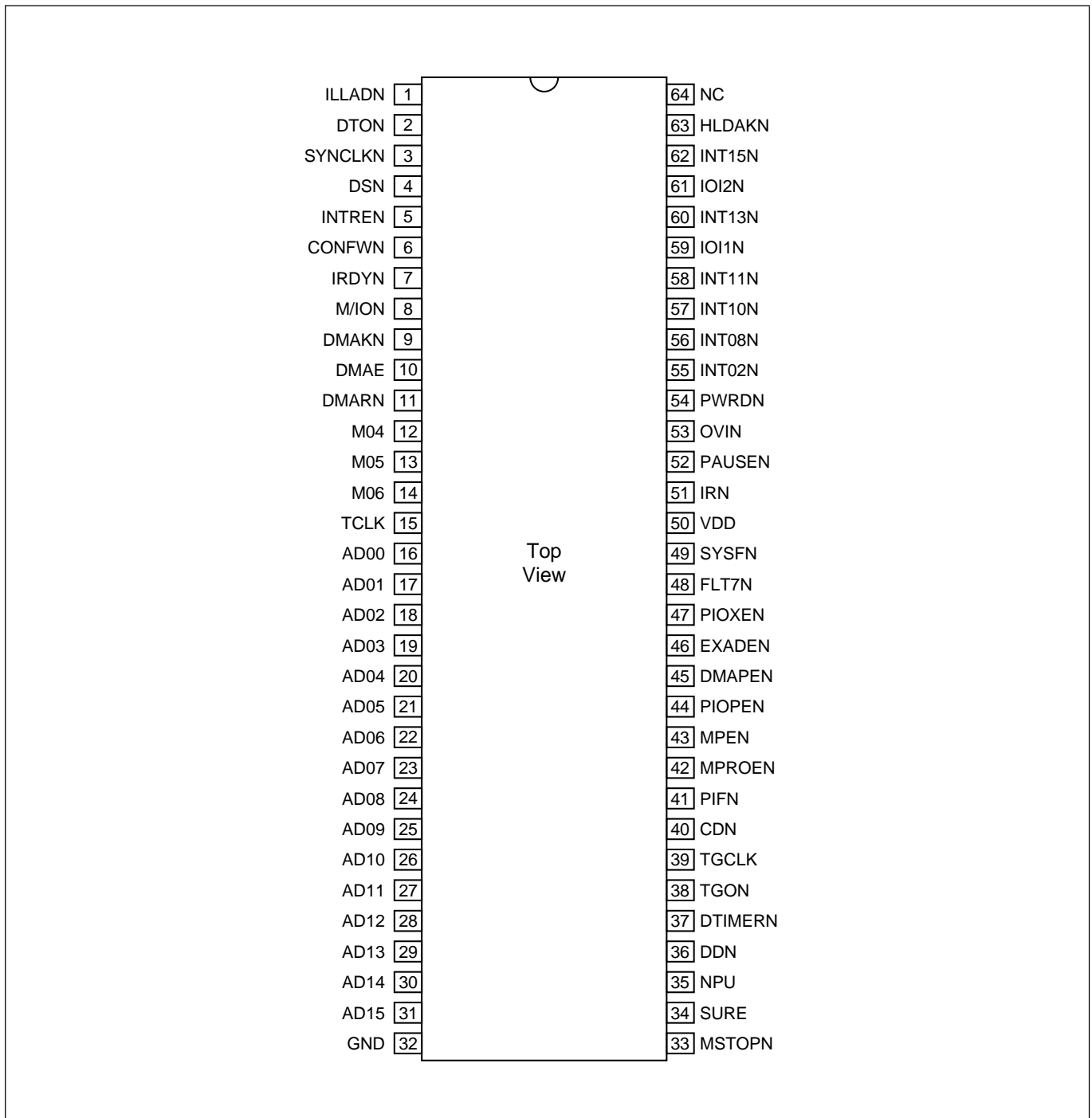

Figure 16b: Pin Assignments

Ref	Millimetres			Inches		
	Min.	Nom.	Max.	Min.	Nom.	Max.
A	1.905	-	2.21	0.075	-	0.087
b1	-	0.51	-	-	0.020	-
D	18.08	-	18.62	0.712	-	0.733
E	18.08	-	18.62	0.712	-	0.733
e	-	1.02	-	-	0.040	-
Z	1.40	-	1.78	0.055	-	0.070

XG493

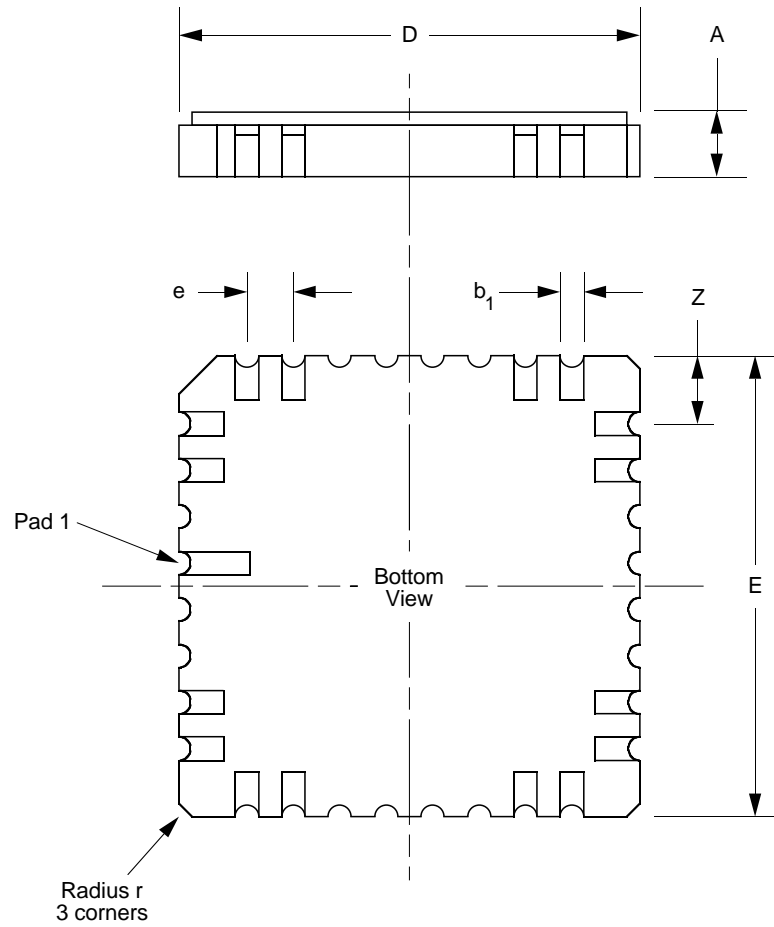

Figure 17a: 64-Lead Leadless Chip Carrier - Package Style L

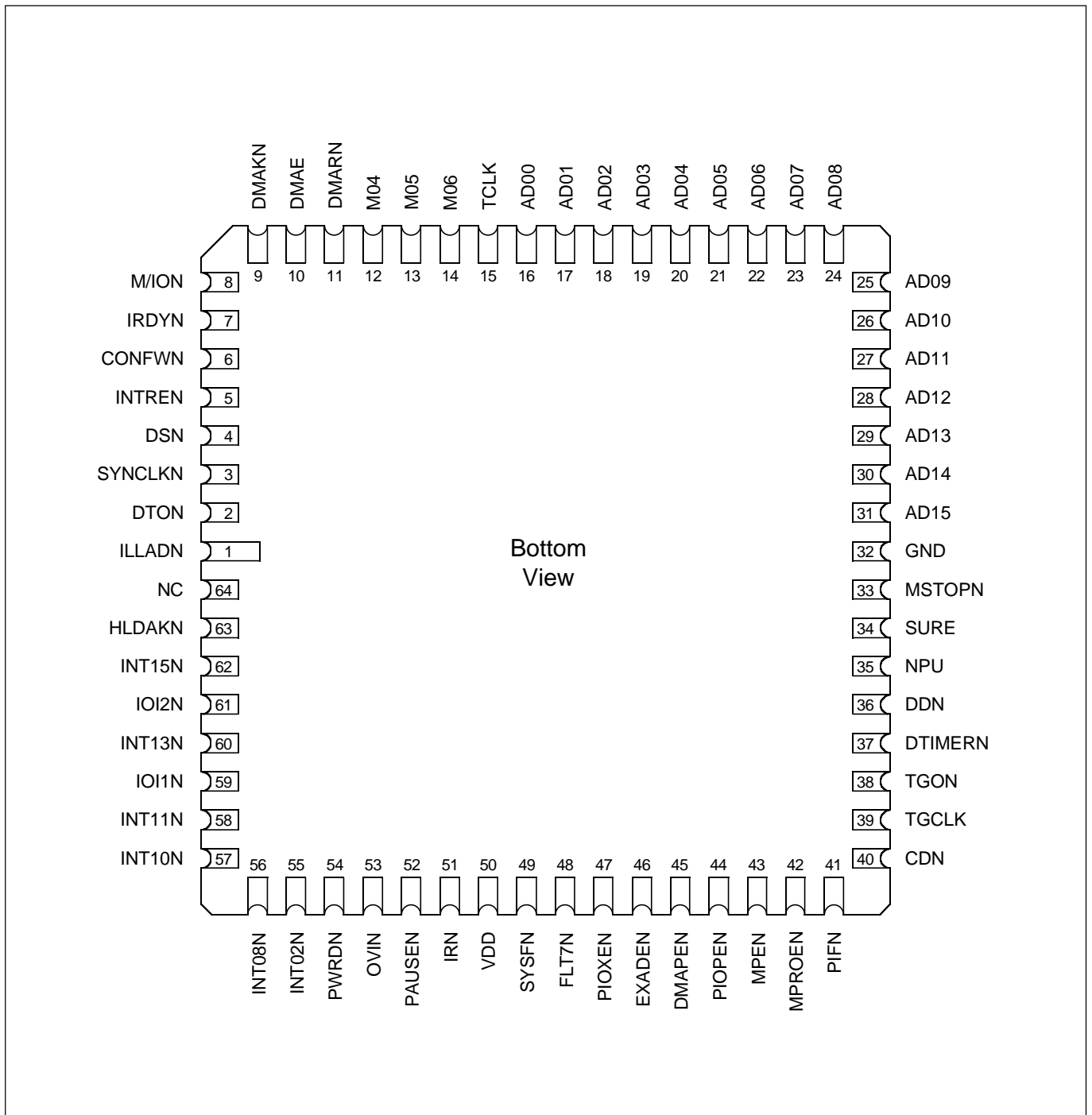

Figure 17b: Pin Assignments

Ref	Millimetres			Inches		
	Min.	Nom.	Max.	Min.	Nom.	Max.
A	-	-	2.72	-	-	0.107
A1	1.83	-	2.24	0.072	-	0.088
b	0.41	-	0.51	0.016	-	0.020
c	0.20	-	0.30	0.008	-	0.012
D1, D2	23.88	-	24.51	0.940	-	0.960
e	-	2.54	-	-	0.050	-
j1	-	1.02	-	-	0.040	-
j2	-	0.51	-	-	0.020	-
L	10.16	-	10.54	0.400	-	0.415
Z	1.65	-	2.16	0.065	-	0.085

XG540

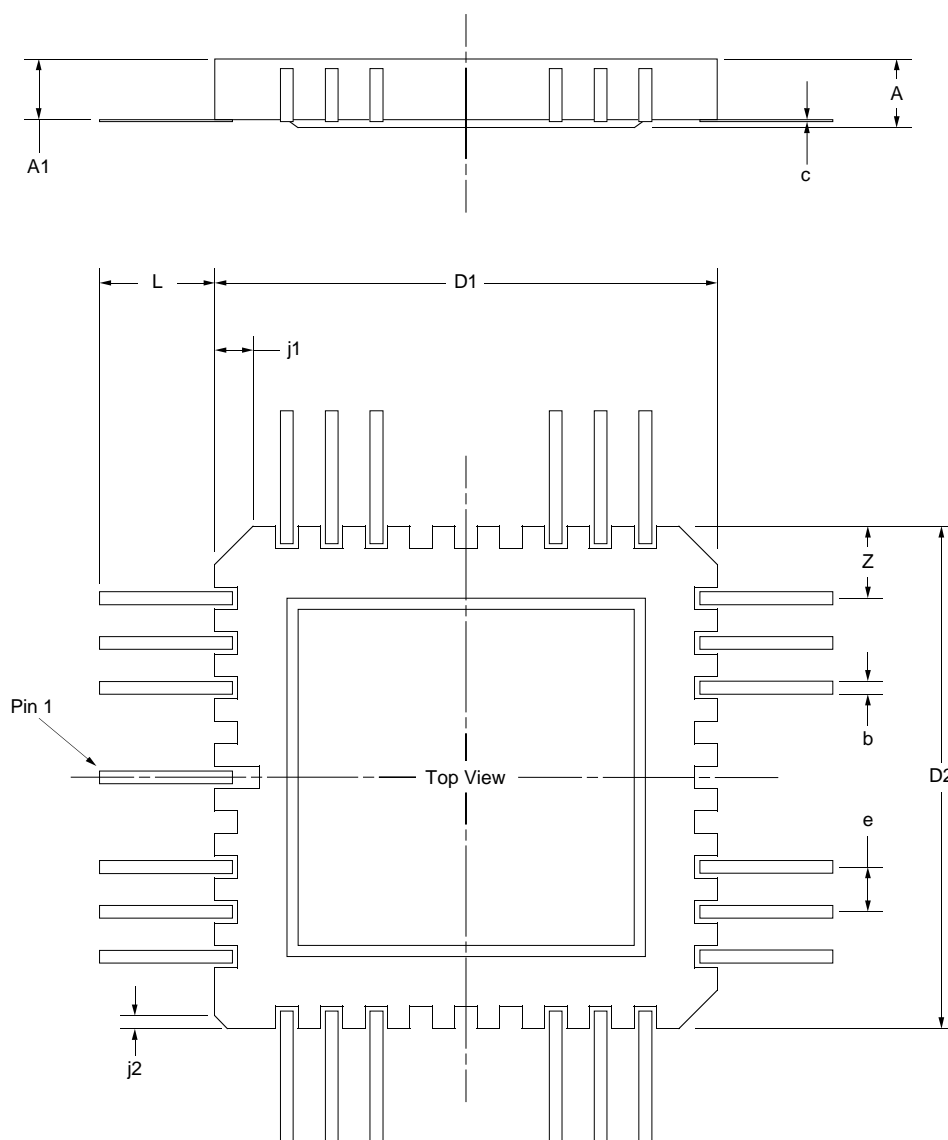

Figure 18a: 68-Lead Topbrazed Flatpack - Package Style F

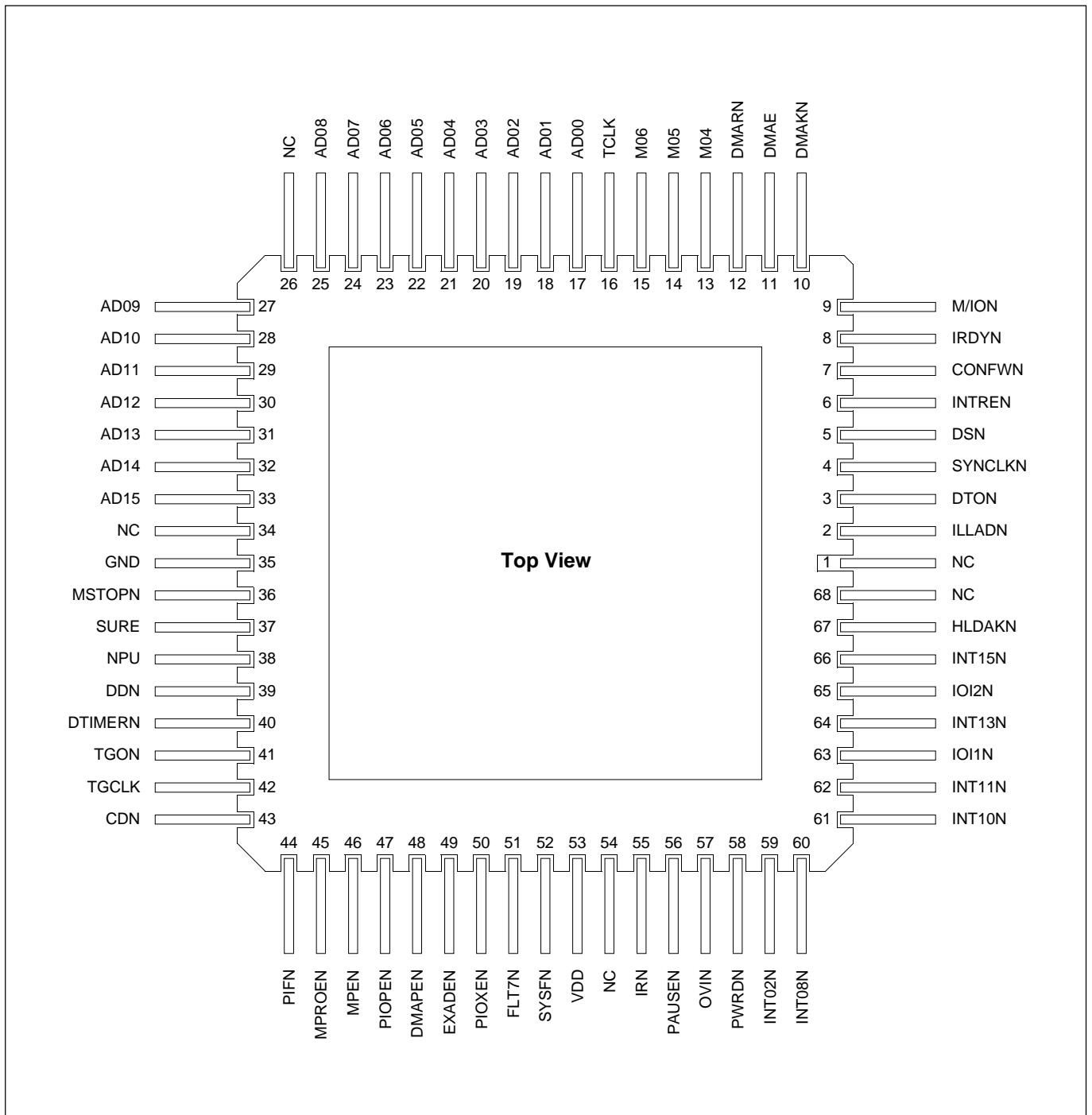

Figure 18b: Pin Assignments

9.0 RADIATION TOLERANCE

Total Dose Radiation Testing

For product procured to guaranteed total dose radiation levels, each wafer lot will be approved when all sample devices from each lot pass the total dose radiation test.

The sample devices will be subjected to the total dose radiation level (Cobalt-60 Source), defined by the ordering code, and must continue to meet the electrical parameters specified in the data sheet. Electrical tests, pre and post irradiation, will be read and recorded.

Dynex Semiconductor can provide radiation testing compliant with Mil-Std-883 method 1019 Ionizing Radiation (total dose) test.

Total Dose (Function to specification)*	3x10 ⁵ Rad(Si)
Transient Upset (Stored data loss)	1x10 ¹¹ Rad(Si)/sec
Transient Upset (Survivability)	>1x10 ¹² Rad(Si)/sec
Neutron Hardness (Function to specification)	>1x10 ¹⁵ n/cm ²
Single Event Upset**	<1x10 ⁻¹⁰ Errors/bit day
Latch Up	Not possible

* Other total dose radiation levels available on request

** Worst case galactic cosmic ray upset - interplanetary/high altitude orbit

Table 10: Radiation Hardness Parameters

10.0 ORDERING INFORMATION

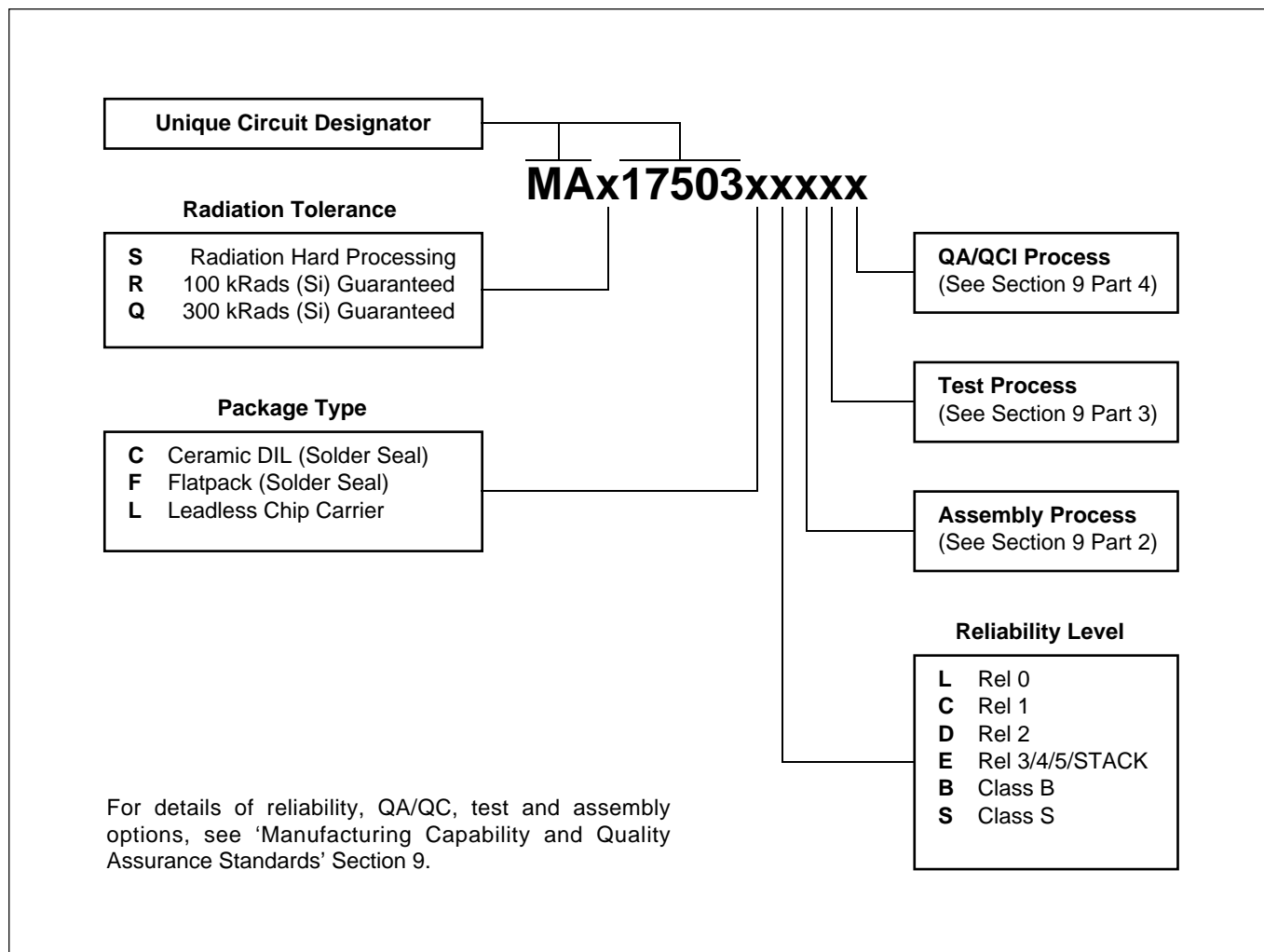



<http://www.dynexsemi.com>

e-mail: space_comms@dynexsemi.com

HEADQUARTERS OPERATIONS
DYNEX SEMICONDUCTOR LTD
Doddington Road, Lincoln.
Lincolnshire. LN6 3LF. United Kingdom.
Tel: +44-(0)1522-500500
Fax: +44-(0)1522-500550

CUSTOMER SERVICE
Tel: +44 (0)1522 502753 / 502901. Fax: +44 (0)1522 500020

SALES OFFICE
Tel: +44 (0)1522 502724. Fax: +44 (0)1522 502777

These offices are supported by Representatives and Distributors in many countries world-wide.
© Dynex Semiconductor 2002 TECHNICAL DOCUMENTATION – NOT FOR RESALE. PRODUCED IN
UNITED KINGDOM

Datasheet Annotations:

Dynex Semiconductor annotate datasheets in the top right hand corner of the front page, to indicate product status. The annotations are as follows:-

Target Information: This is the most tentative form of information and represents a very preliminary specification. No actual design work on the product has been started.

Preliminary Information: The product is in design and development. The datasheet represents the product as it is understood but details may change.

Advance Information: The product design is complete and final characterisation for volume production is well in hand.

No Annotation: The product parameters are fixed and the product is available to datasheet specification.

This publication is issued to provide information only which (unless agreed by the Company in writing) may not be used, applied or reproduced for any purpose nor form part of any order or contract nor to be regarded as a representation relating to the products or services concerned. No warranty or guarantee express or implied is made regarding the capability, performance or suitability of any product or service. The Company reserves the right to alter without prior notice the specification, design or price of any product or service. Information concerning possible methods of use is provided as a guide only and does not constitute any guarantee that such methods of use will be satisfactory in a specific piece of equipment. It is the user's responsibility to fully determine the performance and suitability of any equipment using such information and to ensure that any publication or data used is up to date and has not been superseded. These products are not suitable for use in any medical products whose failure to perform may result in significant injury or death to the user. All products and materials are sold and services provided subject to the Company's conditions of sale, which are available on request.

All brand names and product names used in this publication are trademarks, registered trademarks or trade names of their respective owners.