

# TCM1501B, TCM1506B, TCM1512B TCM1531, TCM1532, TCM1536, TCM1539 TELEPHONE TONE RINGER DRIVERS

D2940 MARCH 1986—REVISED APRIL 1987

- Electronic Replacement for Electromechanical Telephone Bell When Used with Transducer
- Designed to Meet or Exceed FCC Part 68 Class B Ringer Requirements
- Low-Cost External Component Requirements
- Low External Component Count
- High Standby Input Impedance . . . 1 M $\Omega$  Typ
- Low Ringer Equivalency Number . . . < 1 Typ
- Single-Ended High-Voltage Output Compatible with Piezo Transducer or Transformer-Coupled Speaker
- Reliable BIFET<sup>†</sup> Process Technology Provides Efficient High-Voltage Operation
- On-Chip High-Voltage Full-Wave Diode Bridge Rectifier and Output Voltage Regulator
- On-Chip Circuitry Provides Ring Rejection of Rotary Dial Transients, Lightning, and Induced High-Voltage Transients
- On-Chip Thyristor Coupled with Additional External Components Provides Enhanced Rejection of Dial Pulses
- TCM1501B, TCM1512B, and TCM1506B are Improved Direct Replacements for TCM1501A, TCM1512A, and TCM1506A, Respectively
- Requires Only a Single-Value Oscillator Resistor Which Eliminates Binning Codes of the TCM15XXA Series

## P PACKAGE (TOP VIEW)

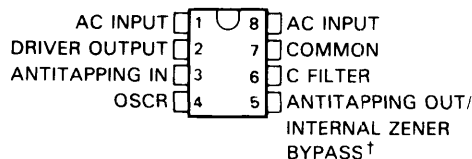

<sup>†</sup> Antitapping Output for TCM1531, TCM1532, TCM1536, and TCM1539. Internal Zener Bypass for B-suffix versions.

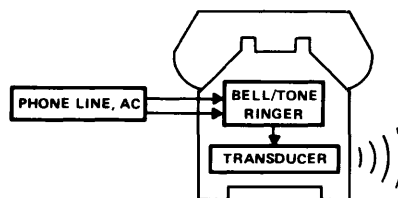

TYPICAL CHARACTERISTICS  
TELEPHONE TONE RINGER DRIVER FAMILY

PART NO.	NOMINAL OUTPUT CENTER FREQUENCY (Hz)	WARBLE RATIO (f <sub>H</sub> :f <sub>L</sub> )	NOMINAL WARBLE FREQ. (Hz)
TCM1501B, TCM1531	2000	8:7	7.8
TCM1512B, TCM1532	1250	8:7	9.8
TCM1506B, TCM1536	500	5:4	7.8
TCM1539	2000	5:4	31.2

## description

The TCM1501B, TCM1506B, TCM1512B, TCM1531, TCM1532, TCM1536, and TCM1539 are monolithic integrated circuit telephone tone ringer drivers that, when coupled with an appropriate transducer, replace the electromechanical bell. These devices are designed, using BIFET<sup>†</sup> technology, for use with either a Piezo transducer or an inexpensive transformer-coupled speaker to produce a pleasing tone composed of a high frequency (f<sub>H</sub>) alternating with a low frequency (f<sub>L</sub>) resulting in a warble frequency. Each device is powered and activated by the telephone line ring voltage, which may vary from 40 volts to 150 volts rms at frequencies from 15.3 hertz to 68 hertz.

During low voltage (off-hook) standby, typical input impedance is greater than 1 megohm; this prevents interference with telephone DTMF or voice signals without the use of expensive mechanical switches. This high standby impedance is achieved with an on-chip series zener diode that is activated by a differential input voltage of typically 8.9 volts at pins 1 and 8. A voltage level of typically 17 volts differential at pins



Caution. These devices have limited built-in gate protection. The leads should be shorted together or the device placed in conductive foam during storage or handling to prevent electrostatic damage to the MOS gates.

<sup>†</sup>BIFET — Bipolar, double-diffused, N-channel and P-channel, MOS transistors on the same chip—patented process.

PRODUCTION DATA documents contain information current as of publication date. Products conform to specifications per the terms of Texas Instruments standard warranty. Production processing does not necessarily include testing of all parameters.

TEXAS  
INSTRUMENTS

POST OFFICE BOX 655303 • DALLAS, TEXAS 75265

Copyright © 1987, Texas Instruments Incorporated

2

Telecommunications Circuits

# TCM1501B, TCM1506B, TCM1512B TCM1531, TCM1532, TCM1536, TCM1539 TELEPHONE TONE RINGER DRIVERS

## description (continued)

1 and 8 deactivates the internal zener diode, allowing for more efficient power transfer to the load when the device is in the operating mode. During ringing, the impedance of the applied circuit (see Figures 4, 5 and 6) varies from 30 kilohms to 8 kilohms over the Class B ring signal, and is reasonably independent of the output load.

These devices feature lightning and transient protection circuitry designed to withstand transients of 1.5 kilovolt for up to 200 microseconds duration when used with the proper external circuitry (see Figures 4 and 5). In addition, an on-chip thyristor coupled with an external resistor and capacitor circuit will reject dial pulses from parallel telephones so that false ringing (tapping) will not occur (see Typical Application Data).

The TCM1501B, TCM1506B, and TCM1512B have a provision for bypassing the internal series diode with one of lower voltage, thereby lowering the turn-on threshold of the device. If the antitapping thyristor is used with these devices, an external zener diode must be added in series with pin 5.

These telephone tone ringer drivers may be used in nontelephone communications applications. For example, the devices can be used with a few external components to produce an inexpensive and highly efficient alarm (see Figure 6).

## functional block diagram

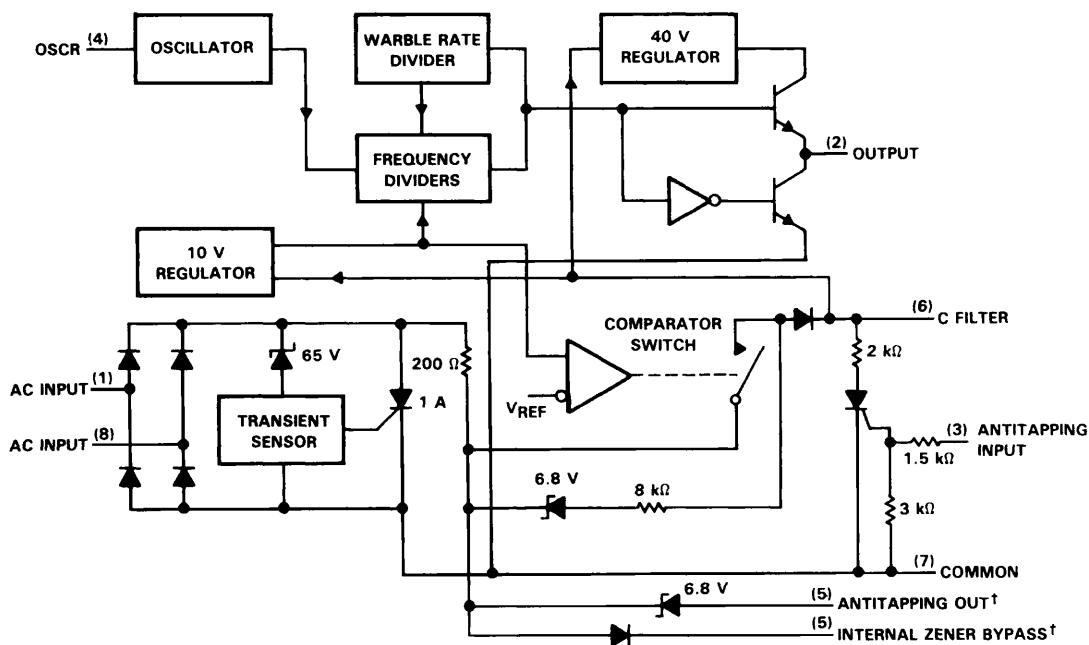

† Antitapping output for TCM1531, TCM1532, TCM1536, and TCM1539. Internal Zener Bypass for B-suffix versions.

**TCM1501B, TCM1506B, TCM1512B  
TCM1531, TCM1532, TCM1536, TCM1539  
TELEPHONE TONE RINGER DRIVERS**

**absolute maximum ratings**

Continuous peak-to-peak input voltage, pin 1 to pin 8 (see Note 1) .....	110 V
Continuous dc input voltage at pin 6 .....	55 V
Negative dc voltage, any pin .....	-1.2 V
Continuous output current, $I_O$ , at pin 2 .....	12 mA
Continuous output current, pin 5 and pin 6 .....	30 mA
Continuous SCR on-state input current, pin 1 to pin 8 .....	200 mA
SCR on-state input current, pin 1 to pin 8 (duration $\leq 200 \mu\text{s}$ ) .....	900 mA
Continuous total dissipation at (or below) 25°C free-air temperature (see Note 2) .....	1000 mW
Operating free-air temperature range .....	-40°C to 85°C
Storage temperature range .....	-40°C to 125°C

NOTES: 1. For applications requiring  $\geq 38 \text{ Vrms}$ , an external resistor and capacitor are required to prevent damage to the device (see Note 3). Tip and ring may be connected interchangeably to either pin 1 or pin 8.  
2. For operation above 25°C free-air temperature, derate linearly at the rate of 8 mW/°C.

**recommended operating conditions**

	MIN	MAX	UNIT
RMS input voltage, $V_I$ ( $f = 15.3 \text{ Hz}$ to $68 \text{ Hz}$ ) (see Note 3)	40	150	V
Resistor between OSCR and COMMON, $R_{osc}$	120	180	$\text{k}\Omega$
Operating free-air temperature, $T_A$	-20	70	°C

NOTE 3: Input voltage is applied to pins 1 and 8 through a series  $2.2 \text{ k}\Omega \pm 10\%$  resistor and a  $0.47 \mu\text{F} \pm 10\%$  capacitor (see Figures 4, 5, and 6).

**electrical characteristics at 25°C free-air temperature,  $R_L = \text{open}$ ,  $C(f_{ltr}) = 10 \mu\text{F}$ ,  $f = 20 \text{ Hz}$  (unless otherwise noted), see Figure 2**

**detector section**

PARAMETER	TEST CONDITIONS	MIN	TYP	MAX	UNIT
Ringing start threshold voltage	Pin 5 open, $R_L = 4 \text{ k}\Omega$		19	28	V
Ringing start threshold rms voltage	Pin 5 open, $R_L = 4 \text{ k}\Omega$ , $f = 15.3 \text{ Hz}$			40	V
Ringing stop threshold voltage	Pin 5 open, $R_L = 4 \text{ k}\Omega$	7	11		V
Ringing start threshold voltage	Antitapping thyristor activated		40		V
Pin 3 voltage required to activate antitapping thyristor			1		V
Pin 3 input current required to activate antitapping thyristor			0.2		mA
Standby input impedance	$V_i = 3 \text{ V}$ , $f \leq 20 \text{ kHz}$	0.1	1		$\text{M}\Omega$
	$V_i = 3 \text{ V}$ , $f \leq 20 \text{ kHz}$ (see Note 5)		10		$\text{k}\Omega$
Impedance when ringing	$V_i = 40 \text{ V}$ , $R_L = 4 \text{ k}\Omega$ , $f = 15.3 \text{ Hz}$		25		$\text{k}\Omega$
	$V_i = 130 \text{ V}$ , $R_L = 4 \text{ k}\Omega$		22		
Operating current	Pin 2 open, $V_I = 40 \text{ V}$			1.3	mA
Low-level input current	$V_I = 5 \text{ V}$			20	$\mu\text{A}$
SCR trigger voltage (pin 1 to pin 8)	All pins open, $I_I \leq 125 \text{ mA}$ (see Note 4)	50	60	100	V
SCR trigger current (pin 1 to pin 8)	All pins open, $V_I \leq 100 \text{ V}$ (see Note 4)	55	80	110	mA
SCR input hold current	(see Note 4)		10		mA

NOTES: 4. These parameters are measured using pulse techniques ( $t_w \leq 200 \mu\text{s}$ , duty cycle  $\leq 5\%$ ).  
5. Pin 5 connected to pin 6, and pin 6 connected to pin 7 through a  $100 \Omega$  resistor.

**TCM1501B, TCM1506B, TCM1512B  
TCM1531, TCM1532, TCM1536, TCM1539  
TELEPHONE TONE RINGER DRIVERS**

electrical characteristics at 25 °C free-air temperature,  $C_{(fltr)} = 10 \mu\text{F}$ ,  $f = 20 \text{ Hz}$  (unless otherwise noted), see Figure 2

**output section**

PARAMETER	TEST CONDITIONS	MIN	TYP	MAX	UNIT
Output voltage, pin 2	$V_I = 17 \text{ V}$ , $I_O = 2 \text{ mA}$ , See Note 6		10		V
	$V_I = 50 \text{ V}$ , $I_O = 5 \text{ mA}$ , See Note 6		44		
	$V_i = 40 \text{ V}$ , $I_O = 2 \text{ mA}$ , $f = 16 \text{ Hz}$		8		
	$V_i = 150 \text{ V}$ , $I_O = 2 \text{ mA}$ , $f = 15.3 \text{ Hz}$		40		
Output voltage, pin 6 (See Note 7)	$V_i = 150 \text{ V}$ , $f = 15.3 \text{ to } 68 \text{ Hz}$			55	V
High-level output current	$V_I = 50 \text{ V}$ , $V_{OH} = 43 \text{ V}$		-15		mA
Low-level output current	$V_I = 50 \text{ V}$ , $V_{OL} = 1.5 \text{ V}$ , See Note 6		11		mA

NOTES: 6. Devices must be forced to the required output state by taking pin 4 to 8 V and toggling to 0 V as required. This stops the on-chip oscillator.

7. Normal device operation requires that a capacitor be connected from pin 6 to common (pin 7). A 10  $\mu\text{F}$  capacitor is recommended for optimum antitapping vs turn-off-time performance of the circuit. Increasing or decreasing the value of this capacitor will respectively increase or decrease the antitapping capabilities of the circuit.

**oscillator section**

PARAMETER	TEST CONDITIONS	MIN	TYP	MAX	UNIT	
Output tone frequency High tone frequency/ Low tone frequency	$R_{osc} = 150 \text{ k}\Omega \pm 1\%$	TCM1501B, TCM1531	1983/1736	2133/1867	2283/1998	Hz
		TCM1512B, TCM1532	1239/1085	1333/1167	1427/1249	
		TCM1506B, TCM1536	516/414	555.5/445.5	595/477	
		TCM1539	2066/1653	2222/1778	2378/1903	
Warble frequency	$R_{osc} = 150 \text{ k}\Omega \pm 1\%$	TCM1501B, TCM1531		7.8		Hz
		TCM1512B, TCM1532		9.8		
		TCM1506B, TCM1536		7.8		
		TCM1539		31.2		
Temperature coefficient of frequency	$T_A = -20 \text{ }^\circ\text{C to } 70 \text{ }^\circ\text{C}$		$\pm 0.05$		%/ $^\circ\text{C}$	

PARAMETER MEASUREMENT INFORMATION

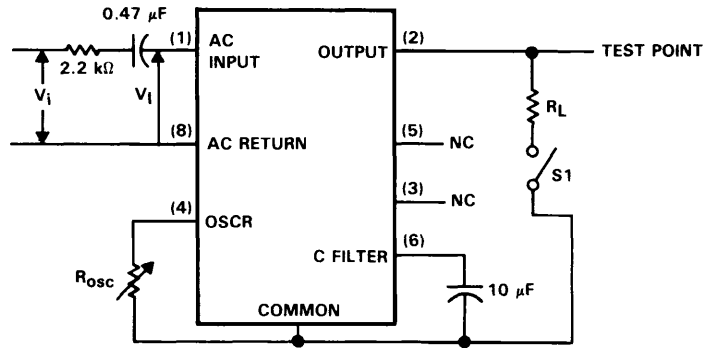

FIGURE 1. TEST CIRCUIT

TYPICAL CHARACTERISTICS

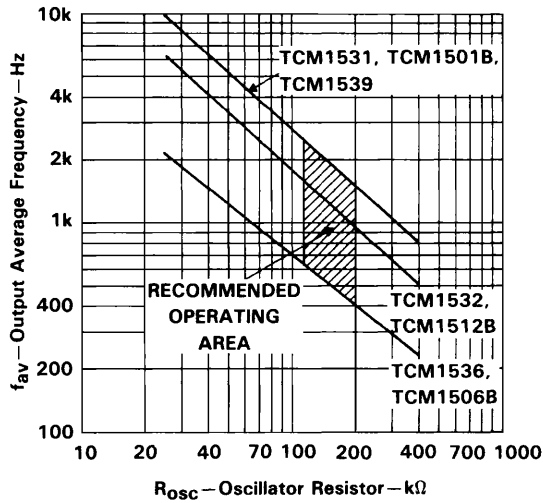
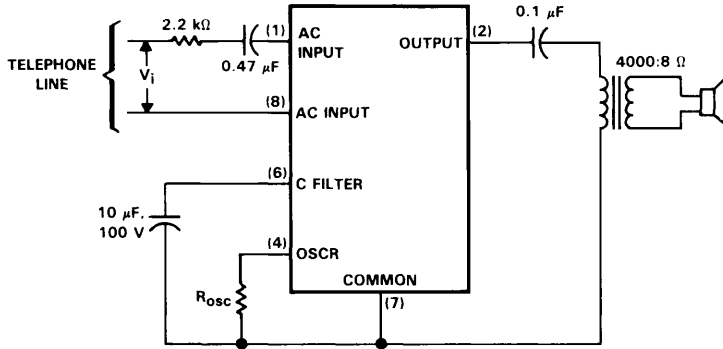

FIGURE 2. OSCILLATOR RESISTOR vs OUTPUT AVERAGE FREQUENCY

**TCM1501B, TCM1506B, TCM1512B  
TCM1531, TCM1532, TCM1536, TCM1539  
TELEPHONE TONE RINGER DRIVERS**

**TYPICAL APPLICATIONS**



**FIGURE 3. TELEPHONE APPLICATION—SPEAKER DRIVE**

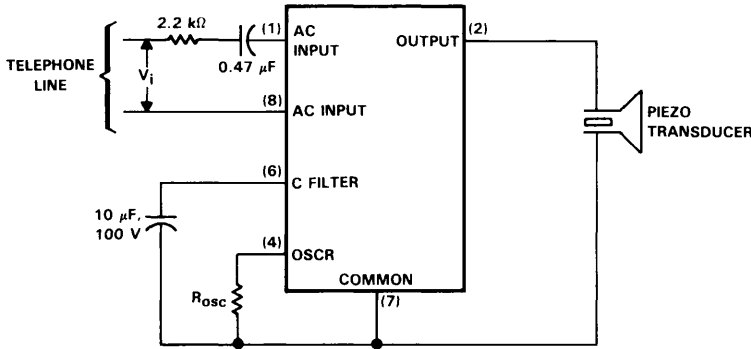

**FIGURE 4. TELEPHONE APPLICATION—PIEZO DRIVE**

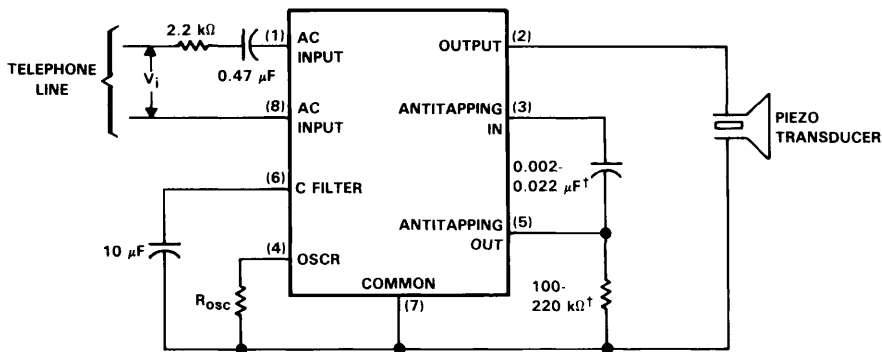

† Optimum values to be determined by specific antitapping requirements.

**FIGURE 5. TELEPHONE APPLICATION, IMPROVED ANTITAPPING CIRCUIT**

TYPICAL APPLICATIONS

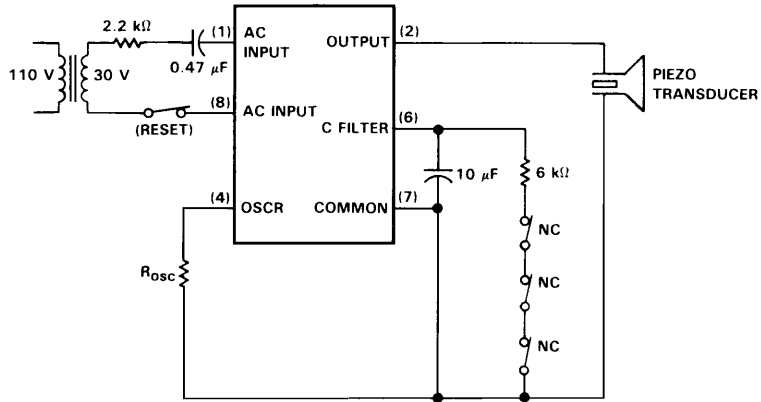

NC -- Normally Closed

FIGURE 6. ALARM SYSTEM CONFIGURATION

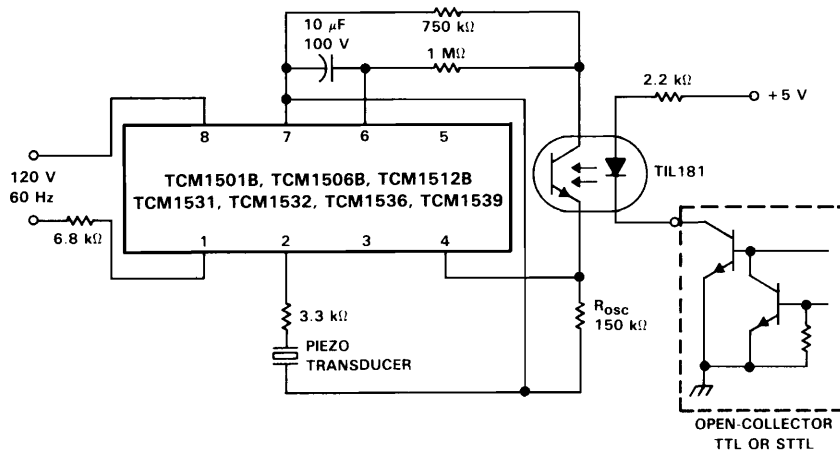

FIGURE 7. NONTELEPHONE APPLICATION

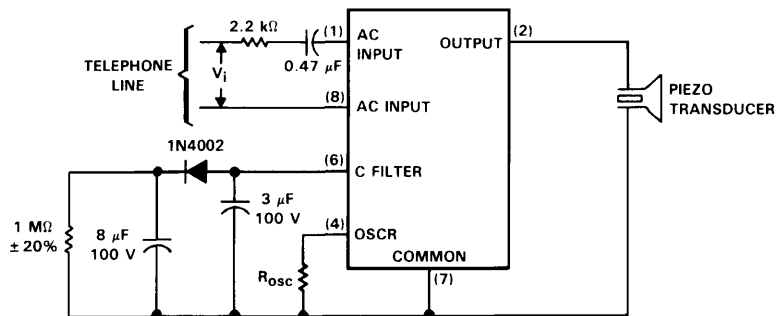

FIGURE 8. TELEPHONE APPLICATION—PIEZO DRIVE FAST RING SIGNAL CUTOFF