

M57785L

135-150MHz, 7.2V, 7W, FM PORTABLE RADIO

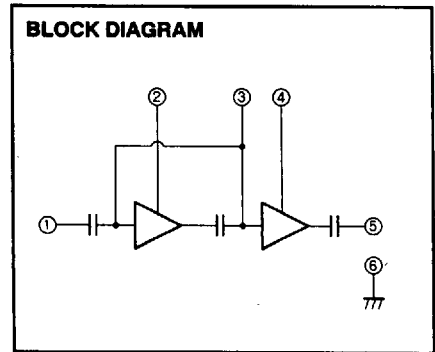
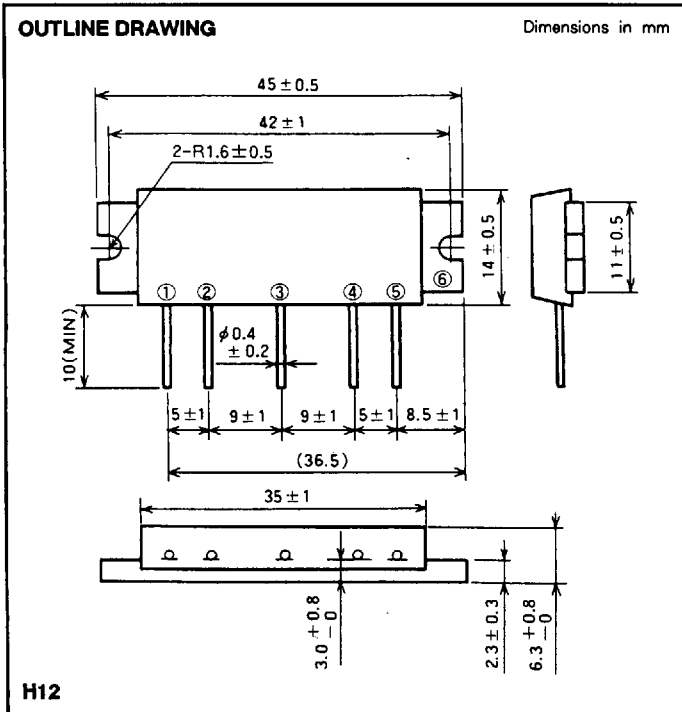

- PIN :**
- ① Pin : RF INPUT
 - ② VCC1 : 1st. DC SUPPLY
 - ③ VBB : BASE BIAS SUPPLY
 - ④ VCC2 : 2nd. DC SUPPLY
 - ⑤ Po : RF OUTPUT
 - ⑥ GND : FIN

ABSOLUTE MAXIMUM RATINGS (Tc = 25 °C unless otherwise noted)

Symbol	Parameter	Conditions	Ratings	Unit
Vcc	Supply voltage		9	V
Vbb	Base bias		6	V
Icc	Total current		4	A
P _{in(max)}	Input power	Vcc1 = 7.2V, Z _G = Z _L = 50 Ω	80	mW
P _{o(max)}	Output power	Z _G = Z _L = 50 Ω	10	W
T _{c(OP)}	Operation case temperature		- 30 to 110	°C
T _{stg}	Storage temperature		- 40 to 110	°C

Note. Above parameters are guaranteed independently.

ELECTRICAL CHARACTERISTICS (Tc = 25 °C unless otherwise noted)

Symbol	Parameter	Test conditions	Limits		Unit
			Min	Max	
f	Frequency range	Vcc1 = Vcc2 = 7.2V Vbb = 5V P _{in} = 50mW Z _G = Z _L = 50 Ω	135	150	MHz
P _o	Output power		7		W
η _T	Total efficiency		40		%
2fo	2nd. harmonic			- 20	dBc
3fo	3rd. harmonic			- 30	dBc
ρ _{in}	Input VSWR			2.5	-
-	Load VSWR tolerance	Vcc1 = Vcc2 = 7.2V, Vbb = 5V P _o = 7W (P _{in} : controlled) Load VSWR ≥ 20 : 1 (All phase) Z _G = 50Ω	No degradation or destroy		-

Note. Above parameters, ratings, limits and conditions are subject to change.

TYPICAL PERFORMANCE DATA

OUTPUT POWER, TOTAL EFFICIENCY, ρ_{in} VS. FREQUENCY CHARACTERISTICS

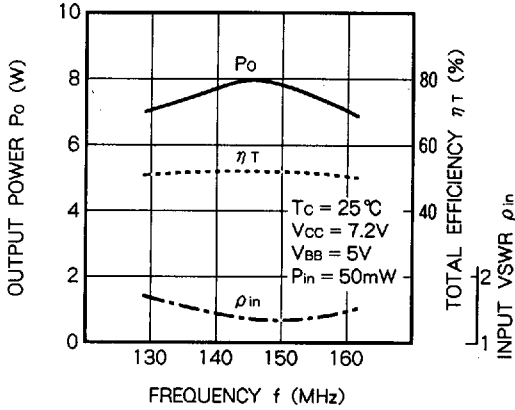

OUTPUT POWER, TOTAL CURRENT, 1st CURRENT VS. INPUT POWER CHARACTERISTICS

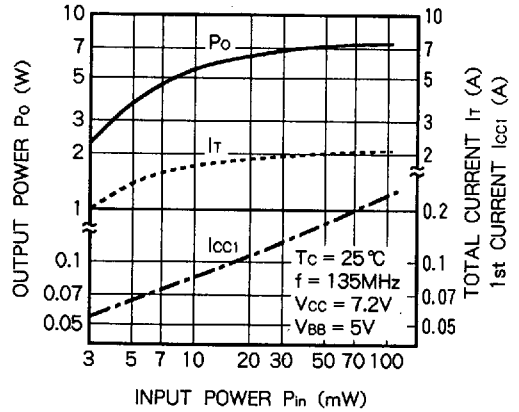

OUTPUT POWER, TOTAL CURRENT, 1st CURRENT VS. INPUT POWER CHARACTERISTICS

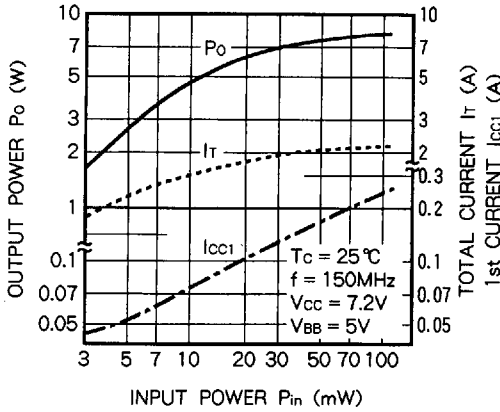

OUTPUT POWER, 2nd CURRENT VS. 1st SUPPLY VOLTAGE CHARACTERISTICS

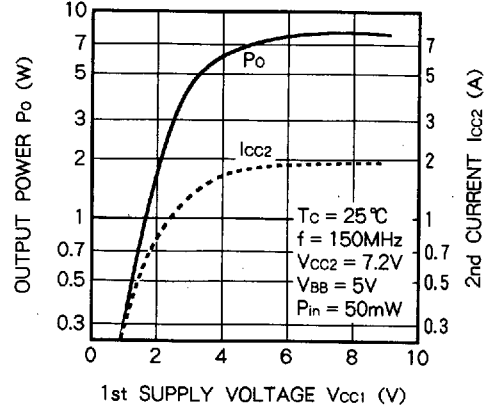

OUTPUT POWER, 2nd CURRENT VS. 1st SUPPLY VOLTAGE CHARACTERISTICS

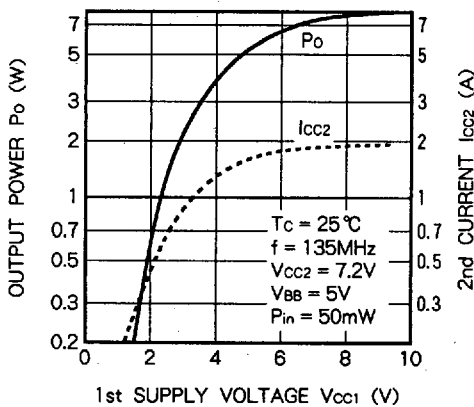

OUTPUT POWER, TOTAL CURRENT, 1st CURRENT VS. SUPPLY VOLTAGE CHARACTERISTICS

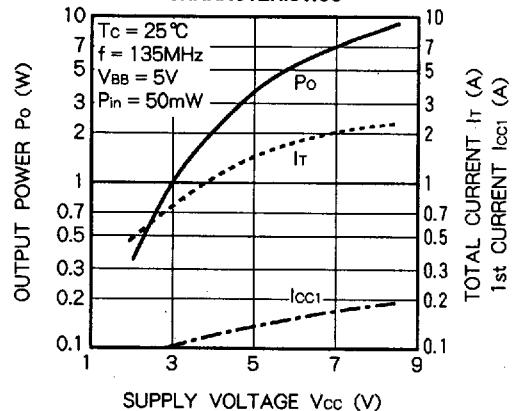

OUTPUT POWER, TOTAL CURRENT, 1st CURRENT VS. SUPPLY VOLTAGE CHARACTERISTICS

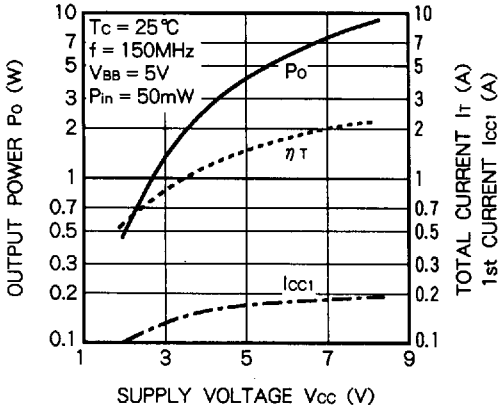

2nd, 3rd HARMONICS VS. FREQUENCY CHARACTERISTICS

