

VIDEO AMPLIFIER

The KA2945 is a silicon monolithic integrated circuit designed for the home video tape recorder.

FUNCTIONS

Recording

- Video AGC (Keyed plus peak detection method)
- EE Monitor squelch

Playback

- FM limiter
- FM demodulation
- Dynamic de-emphasis
- Noise cancel
- Y/C mix
- Squelch

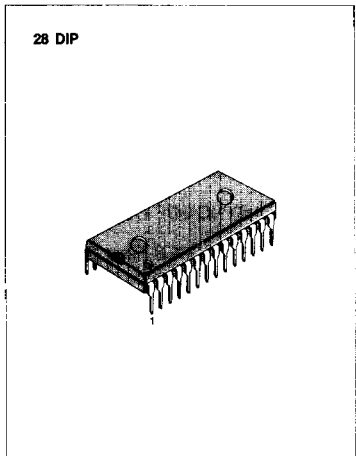







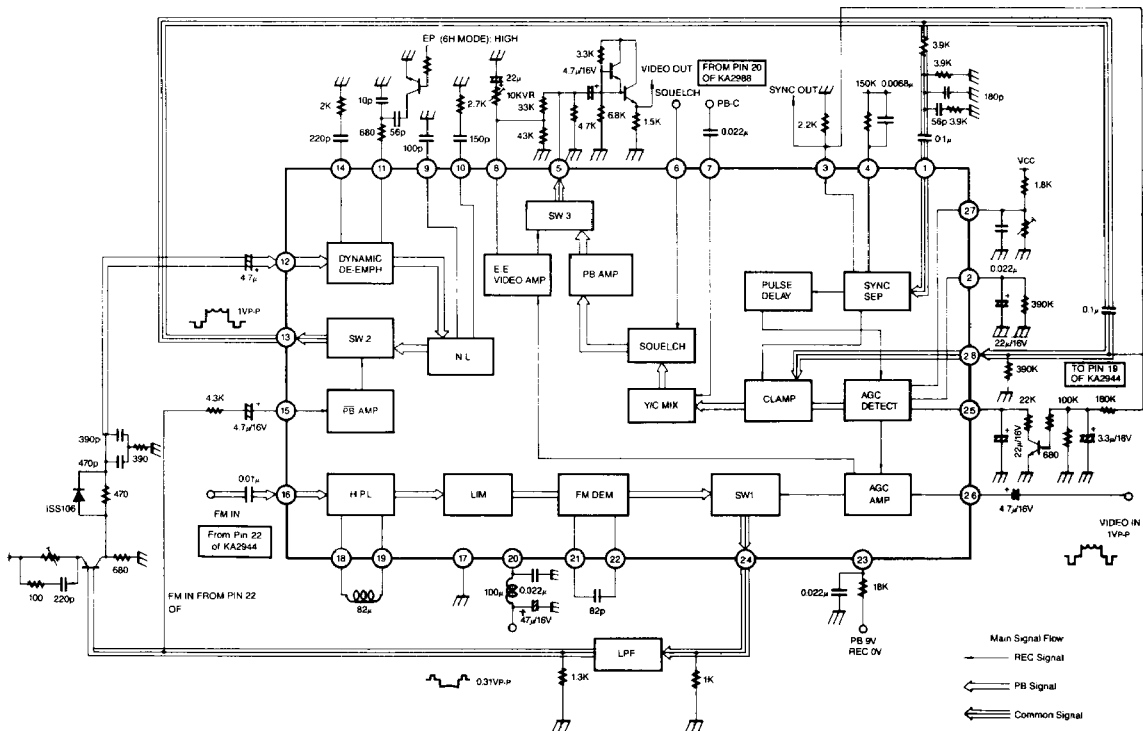

ORDERING INFORMATION

Device	Package	Operating Temperature
KA2945	28 DIP	-10 ~ +75°C

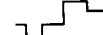
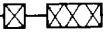
BLOCK DIAGRAM

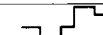

PIN FUNCTIONS

Pin No.	Functions	Signals	Note
1	SYNC SEP Input Terminal	 $\approx 0.5V_{p-p}$	$Z_{IN} = 50k\Omega$
2	Video AGC Filter 1 at Recording		
3	SYNC SEP Output Terminal	 $\approx 8.0V_{p-p}$	
4	SYNC SEP Filter Terminal		
5	EE PB Video Output Terminal	 $\approx 2V_{p-p}$	
6	Squelch Signal Input Terminal at Playback		
7	Playback Color Signal Input Terminal	 $\approx 0.1V_{p-p}$	
8	EE Video Amp. Feedback Terminal		
9	HPF for Noise Cancel		
10	Filter for Noise Cancel		
11	Dynamic De-emphasis Adjusting Terminal		
12	Dynamic De-emphasis Input Terminal		$Z_{IN} = 10k\Omega$
13	Recording and Playback Luminance Signal Output Terminal	 $\approx 1V_{p-p}$	
14	Dynamic De-emphasis Filter		
15	Recording Luminance Signal Input Terminal	 $\approx 0.3V_{p-p}$	Base Grounded Amp
16	Playback FM Limiter Input Terminal	FM Signal	$Z_{IN} = 4.5k\Omega$
17	GND		
18	FM Limiter HPF		
19	FM Limiter HPF		
20	V_{CC}		
21	Capacitor Terminal for FM Demodulation		
22	Capacitor Terminal for FM Demodulation		
23	Bias Terminal for Playback	$\approx 1.8V$	
24	Recording Video AGC and FM Demodulation Output Terminal	 $\approx 0.3V_{p-p}$	Open Collector
25	Video AGC Filter at Recording 2	$\approx 1.45V$	
26	Video AGC Input Terminal at Recording	 $\approx 1V_{p-p}$	$Z_{IN} = 20k\Omega$
27	Video AGC Adjustment Terminal at Recording	DC	Base Input
28	Video AGC Detection Input Terminal at Recording Playback Luminance Signal Input Terminal	 $\approx 1V_{p-p}$	

ABSOLUTE MAXIMUM RATINGS

Characteristic	Symbol	Value	Unit
Supply Voltage	V_{CC}	14.2	V
Power Dissipation	P_d	800* 875**	mW
Operating Temperature	T_{opr}	-10 ~ +75	°C
Storage Temperature	T_{stg}	-40 ~ +125	°C

*Value at $T_a=61^\circ\text{C}$, **Value at $T_a=75^\circ\text{C}$, Recommended supply voltage: $9 \pm 1\text{V}$.

ELECTRICAL CHARACTERISTICS ($T_a=25^\circ\text{C}$, $V_{CC}=9\text{V}$)

Characteristic	Symbol	Test Conditions	Min	Typ	Max	Unit
Quiescent Current at REC	I_{CCR}	at pin 23=0V, Current flowing to Pin 20	19.5	24.3	32.1	mA
AGC Control Characteristics 1	AGC-6	Pin 26 0.5V _{p-p} Video Signal, Pin 28 level (Reference to 1V _{p-p})	-7	-3	+2	%
AGC Control Characteristics 2	AGC+6	Same as above but Pin 26 2V _{p-p}	-2	4	10	%
AGC Control Characteristics 3	AGC-S	Same as above but Pin 26 Video 0.7V, SYNC 0.15V	-2	5	12	%
REC Amp Gain	G_{REC}	Pin 15 Sine wave 0.5MHz, 0.3V _{p-p} Input Pin 13 Output	8.4	10.2	12.0	dB
AGC DET Amp Gain	G_{AD}	Pin 28 Sine wave 0.5MHz, 1V _{p-p} Input Pin 2 Output	—	5.5	—	dB
AGC DET Adding Pulse Width	PW_{AD}	Pin 28, 1V _{p-p} Video Signal Input	—	2.0	—	μs
AGC DET Front Edge Delay Time	t_{AD}	Same as above	—	1.0	—	μs
SYNC SEP Output Level	V_{SYC}	Same as above	7.5	8.1	8.5	V _{p-p}
SYNC SEP Output Pulse Width	PW_{SYC}	Same as above	5.25	5.75	6.20	μs
SYNC SEP Front Edge Delay Time	T_{SYC}	Same as above	—	0.30	—	μs
SYNC SEP Threshold	TH_{SYC}	Input level to reduce Pin 1 input video signal level and increase pins output	—	-7	—	dB
Quiescent Current at PB	I_{CCP}	at Pin 23 High, Current flowing to Pin 20	34.2	43.0	55.9	mA
FM Demodulation Voltage	V_{DEM}	Pin 16 Sine wave 4MHz 50mV _{p-p} Input at Pin 24 DC Voltage	7.60	7.78	7.96	V
FM Demodulation Sensitivity	S_{DEM}	Pin 16 Sine wave 3.5MHz 50mV _{p-p} Input	0.26	0.314	0.36	V

(to be continued)

ELECTRICAL CHARACTERISTICS (continued)

Characteristic	Symbol	Test Conditions	Min	Typ	Max	Unit
FM Demodulation Linearity	L _{DEM}	Linearity of pin 24 Output	-3.5	0.0	+3.5	V
Carrier Leak	CL4	Pin 16 Sine wave 4MHz 0.5V _{p-p} Input (0dB = 0.7 × S _{DEM})	—	-22	—	dB
PB Amp Gain	G _{PB}	Pin 28 Sine wave 0.5MHz 1V _{p-p} Input	5.6	6.5	7.4	dB
PB Color Amp Gain	G _C	Pin 7 Sine wave 3.58MHz 0.1V _{p-p}	15.2	16.5	17.8	dB
PB Squelch Threshold Voltage	V _{SQ}	Pin 6 DC voltage where squelch on	0.9	1.35	2.20	V
DD to NC Main Amp Gain	G _{DN}	Pin 12 Sine wave 0.5MHz 1V _{p-p} Input	0.7	1.6	2.5	dB
Dynamic De-emphasis Response Characteristics 1	G _D 1	Pin 12 Sine wave 0.25MHz 1V _{p-p} Input pin 13 Output	-0.4	0.3	1.0	dB
Dynamic De-emphasis Response Characteristics 2	G _D 2	Same as above but 2MHz 1V _{p-p}	-0.1	0.0	1.0	dB
Dynamic De-emphasis Response Characteristics 3	G _D 3	Same as above but 0.25MHz 0.1V _{p-p}	-3.1	-2.1	-1.1	dB
Dynamic De-emphasis Response Characteristics 4	G _D 4	Same as above but 2MHz 0.1V _{p-p}	-6.7	-5.5	-4.3	dB
Noise Canceller Response Characteristics 1	G _N 1	Same as above but 0.25MHz 0.7V _{p-p}	0.2	1.1	2.0	dB
Noise Canceller Response Characteristics 2	G _N 2	Same as above but 2MHz 0.7V _{p-p}	0.1	1.0	1.9	dB
Noise Canceller Response Characteristics 3	G _N 3	Same as above but 0.25MHz 70mV _{p-p}	-1.4	-0.5	0.4	dB
Noise Canceller Response Characteristics 4	G _N 4	Same as above but 2MHz 70mV _{p-p}	-1.9	-1.0	-0.1	dB

TYPICAL PERFORMANCE CURVES

AGC TEMPERATURE CHARACTERISTIC

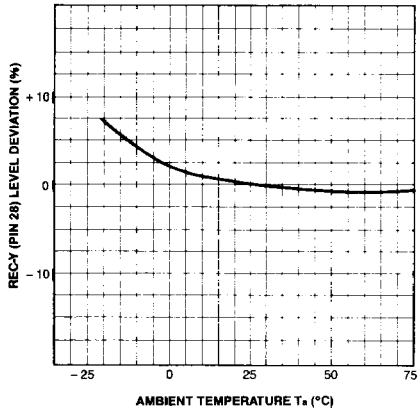

DYNAMIC DE-EMPHASIS CHARACTERISTIC

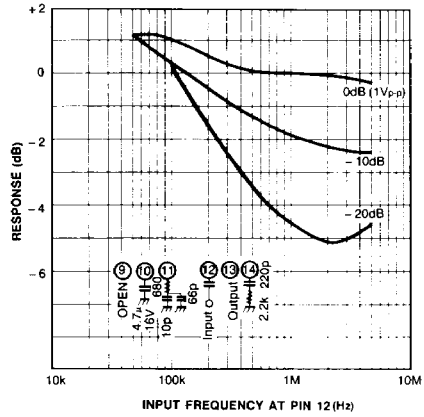

EE AMPLIFIER CHARACTERISTIC

