



YSS915

KP2V2

Karaoke Processor 2 for Video disc player

■ INTRODUCTION

YSS915 (KP2V2) is an LSI for processing Karaoke voice signals.

This LSI has an A/D converter (1 channel) for the microphone echo, and a memory for the microphone echo and key control. These features allow achieving the functions needed for the Karaoke system by using only one LSI chip. As for the microphone echoes, many other types of echoes are available in addition to ordinary ones so that YSS915 is applicable to various uses.

In addition to these Karaoke programs, YSS915 is able to provide the Movie & Music programs, with which the surround effect is applied to the movie and music sources for giving the users more enjoyment.

YSS915 is pin compatible with and register compatible with YSS903 (KP2V).

■ FEATURES

[Fundamental Functions]

1) Karaoke program

- Key Control (Control by 50 cents in +/- 600 cent range, +/- one octave, etc.)

- Voice Cancel

Microphone Echo

- Normal microphone echo (174 msec or less (fs = 44.1 kHz))
- Stereo-Echo/ Reverb-Echo
- Microphone Key Control (+/- 10 cents, +/- 20 cents, +/- 400 cents, +/- 700 cents and +/- 1 octave)
- Microphone wide surround

Tone Control

- Bass, Mid-tone, Treble (0 to +/- 10 dB at 2 dB steps)

Surround

- Yamaha's original wide surround technology

2) Movie and music program

Surround

- Initial reflection sound synthesizing system
- Yamaha's original wide surround technology

Tone Control

- Bass, Mid-tone, Treble (0 to +/- 10 dB at 2 dB steps)

[I/O Interface]

- Digital signal inputs : 2 channels (16/18/20/24 bits)
- Digital signal outputs : 2 channels (16/18/20/24 bits)
- Analog signal input : 1 channel (for the microphone)
- Microprocessor interface : Serial four line system
- Through-mode : Digital input is outputted without any processing
(Correspond with fs = 96 kHz 24 bit DVD format)

[Others]

- Pin/register upper compatible with YSS903 (KP2V)
- Sampling frequency : 32, 37.8, 44.1, 48 kHz or correspond with 96 kHz through-mode.
- Package : 28 pin SOP (YSS915-MZ)

YAMAHA CORPORATION

YSS915 CATALOG
CATALOG No:LSI-4SS915A50
2007.7

■ Difference between YSS903 and YSS915

1. No built-in DAC.
(Refer to the process flow chart in “OPERATIONS”.)
2. Connectable directly with MSB justified data output ADC.
(Refer to “Format 4” of “4. Digital audio interface” in “PIN FUNCTIONS”.)
3. Microphone interface pins CDI and CDO can be connected on the board.
This feature allows to reduce the number of ports by one.
(Refer to “5. Microcomputer interface” in “PIN FUNCTIONS”.)
4. Input fader has been added for the microphone echo.
This feature allows to apply fade-in/fade-out control to the microphone echo through designation with one bit from the microcomputer.
(Refer to “1. Karaoke program” in “OPERATIONS”, and “3) VCR (\$02)” of “1. Functions” in “REGISTERS”.)
5. Zero level detection function has been added for digital audio output.
YSS915 outputs “0” at the pin “ZERO” when an audio input has been zero for a certain period.
This signal can be used to improve S/N ratio by muting the output of external DAC.
(Refer to “6. Others” in “PIN FUNCTIONS”.)
6. An output port PO has been added for controlling peripheral devices.
The port “PO” can be used, as an example, to control the gain of audio output amplifier through this LSI from the microcomputer.
(Refer to “6. Others” in “PIN FUNCTIONS”.)
7. A mode with extended band width for microphone echo has been newly added.
Two types of cut-off frequency have been added for the low pass filter.
(Refer to “7) RVR (\$06)” and “11) MDR (\$1C)” of “1. Functions” in “REGISTERS”.)
8. Internal DSP has been given the operation accuracy of 20 bits.
Internal multiplier-accumulator become $20\text{bit} \times 13\text{bit} = 24\text{bit}$ therefore overall bit accuracy become improved from 18bit(YSS903) to 20bit(YSS915).
In through-mode which internal DSP is not used for processing the accuracy of input data is maintained to output.

■ PIN CONFIGURATION

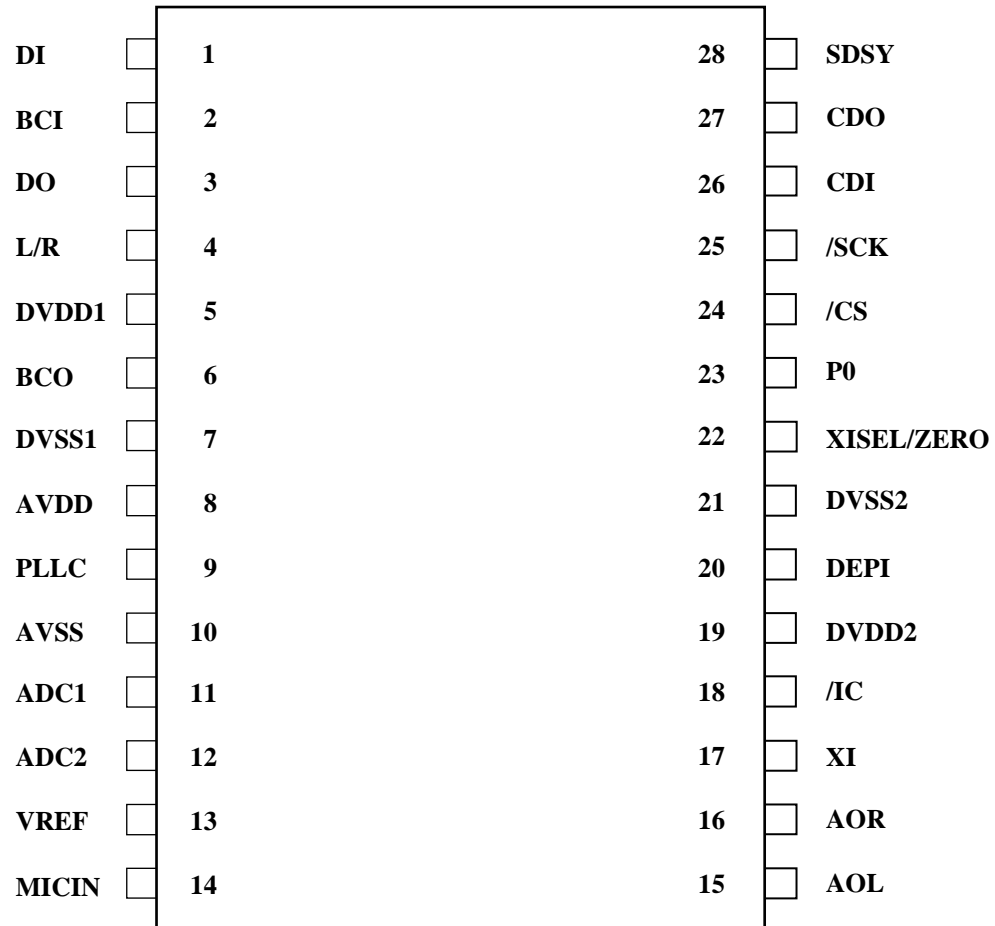

< 28pin SOP Top View >

■ PIN FUNCTION

No.	Name	I/O (*1)	Function
1	DI	I+	Digital audio input Serial data
2	BCI	I+	Digital audio input Bit clock
3	DO	O/+	Digital audio output Serial data / Test input pin (*2)
4	L/R	O	Digital audio output Word clock
5	DVDD1	-	Power supply, +5 V (for digital system)
6	BCO	O	Digital audio output Bit clock
7	DVSS1	-	Ground (for digital system)
8	AVDD	-	Power supply, +5 V (for analog system)
9	PLLC	A	Connecting resistor and capacitor for PLL
10	AVSS	-	Ground (for analog system)
11	ADC1	A	Connecting capacitor for ADC
12	ADC2	A	Connecting capacitor for ADC
13	VREF	OA	Referential voltage output
14	MICIN	IA	Analog input, analog voice signal for microphone channel
15	AOL	OA	Outputs analog voice signal for L channel
16	AOR	OA	Outputs analog voice signal for R channel
17	XI	I	External clock input
18	/IC	I	Initial clear (Low active)
19	DVDD2	-	Power supply, +5 V (for digital system)
20	DEPI	I	De-emphasis control (H : On, L : Off)
21	DVSS2	-	Ground (for digital system)
22	XISEL/ZERO	I+/O	Switches master clock rate/ZERO output
23	P0	O/+	P0 output / Test input pin (*2)
24	/CS	I	Microcomputer interface input Chip select
25	/SCK	I	Microcomputer interface input Serial clock
26	CDI	I	Microcomputer interface input Serial data
27	CDO	O+	Microcomputer interface output Serial data
28	SDSY	I+	Digital audio input Word clock

(*1) + : Built in pull-up circuit
 A : Analog pin

(*2) **WARNING:** The LSI implements the test mode in the case of setting DO pin or PO pin to low level when /IC (initial clear) turn from L to H. Please never make DO and PO pin to low level at the time of the /IC's changing. And please note that does not connect the pin with built-in pull-up circuit to another pin with pull-down circuit. Because of the pull-up impedance is high as 100kΩ- 1MΩ, and it would be pull-down if it were connect to pull-down circuit.

■ BLOCK DIAGRAM

This LSI has two input channels (L and R) and two output channels (L and R) for digital audio interface. It also has a one bit Delta-Sigma type AD converter 1 channel (microphone) that performs Delta-Sigma modulation at its analog block, and decimation/interpolation of 128 times at its DSP.

Karaoke audio signal is processed by DSP for processing Karaoke audio signal and RAM for delay.

For the details of Karaoke audio signal processing, please refer to "OPERATIONS".

The parameters of this LSI are set through CPU interface. For the details of the parameters, please refer to "REGISTERS".

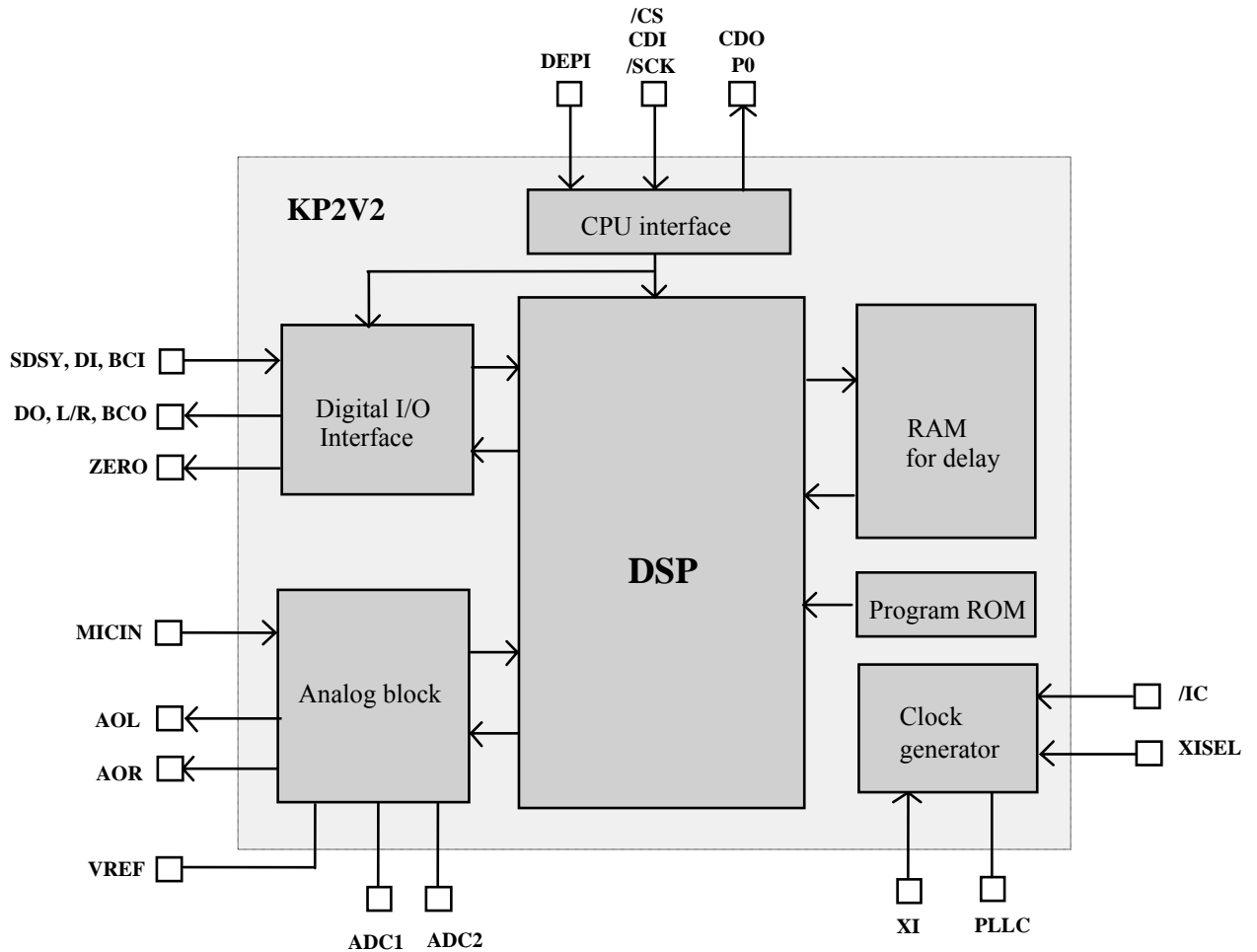

■ MODES

Name of mode	Code	Description
KP2 standard mode	N	The functions of KP2 (YSS216B) can be used. The registers are compatible, except that the coefficient registers (addresses \$27 and \$30 to \$33) of KP2 that controls the analog audio input and analog microphone echo output cannot be used because YSS903 does not have these ports.
KP2V extended mode	E	Every function of this device can be used.

■ PIN FUNCTIONS

1. Clock signal XI, XISEL, PLLC

Operation of this LSI requires input of clock with frequency of 384 fs (fs : sampling frequency) or 256 fs to the XI pin.

Keep the XISEL pin open when using with the 384 fs clock. (XISEL pin is pulled up internally.)

Pull down XISEL pin to the digital ground through 4.7 k ohm resistor when using with the 256 fs clock.

The sampling frequency can be selected in the range from 32 kHz to 48 kHz.

The sampling frequency is specified with OPR register (\$00). (The sampling frequency of fs = 32 or 48 kHz can be specified only KP2V Extended mode.)

Sampling frequency (fs)	XI input frequency		Available mode (See Note.)
	384fs	256fs	
32.0 kHz	12.288 MHz	8.192 MHz	E
37.8 kHz	14.5152 MHz	9.6768 MHz	N, E
44.1 kHz	16.9344 MHz	11.2896 MHz	N, E
48.0 kHz	18.432 MHz	12.288 MHz	E

Note:
 N = KP2 standard mode
 E = KP2V extended mode

In addition, the thing that input 37MHz in XI by a maximum is possible in only through-mode.

Connect a resistor and capacitor to PLLC pin as shown below for adjustment of PLL in the LSI.

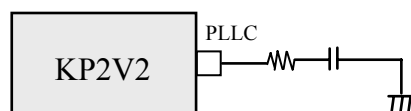

2. Initial clear /IC

This LSI requires initial clear at power on. The initial clear is performed by inputting "L" to /IC pin.

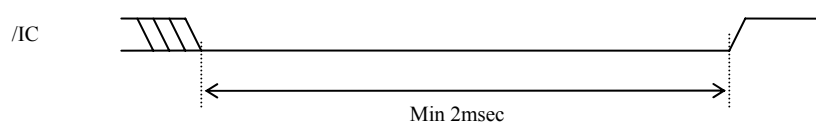

3. Analog audio interface MICIN, ADC1, ADC2, AOL, AOR, VREF

This LSI has a one channel (MIC input) of Delta-Sigma type A/D converter, thus requiring the external circuits as described below.

The output of AOL and AOR can be used as a direct signal from the microphone because the volume of the signal is controlled as analog signal which is outputted from AOL and AOR.

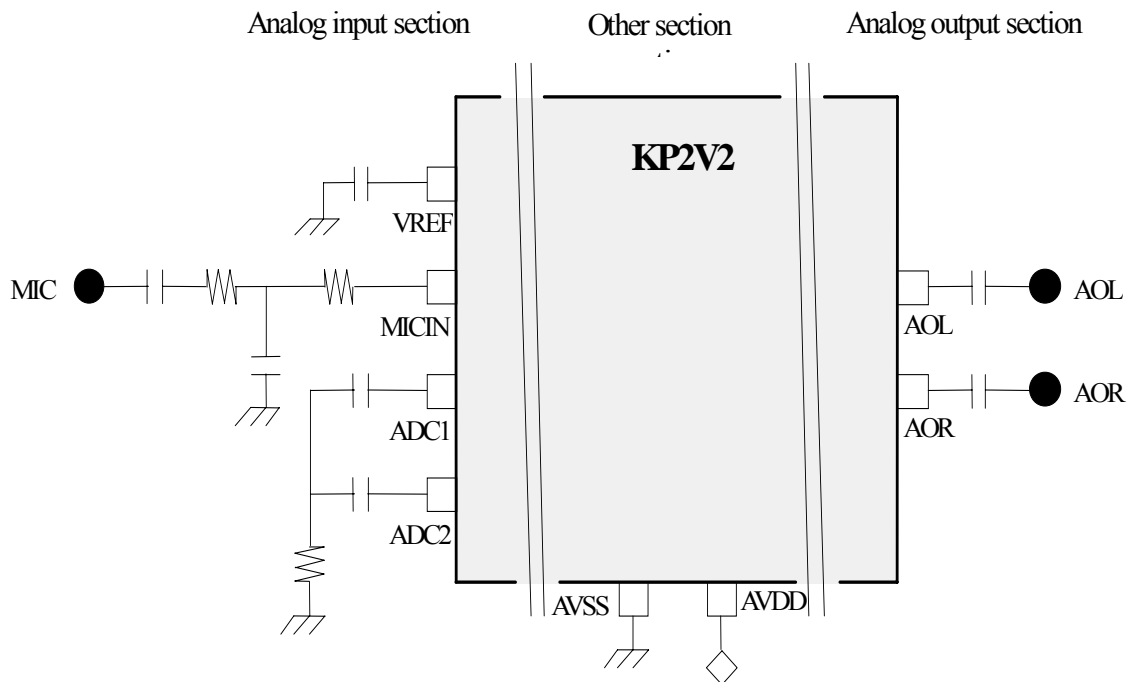

4. Digital audio interface SDSY, BCI, DI, L/R, DO, BCO

-1) Digital audio signal is inputted through BCI, SDSY and DI pins using the following format.

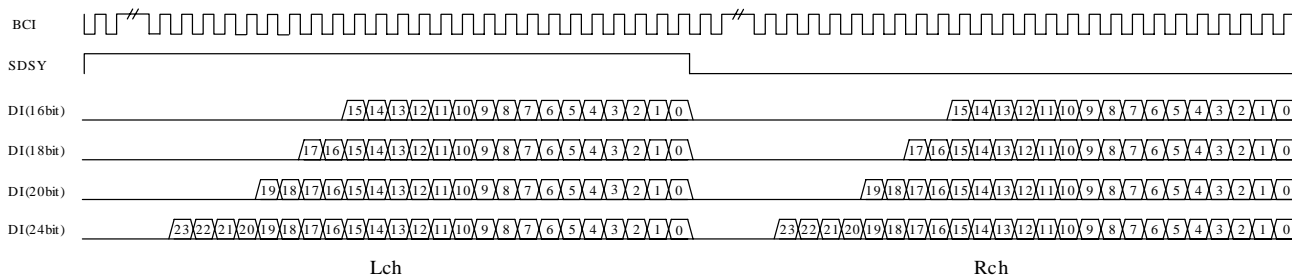

-2) Digital audio signal is outputted through BCO, L/R, and DO pins using the following format.

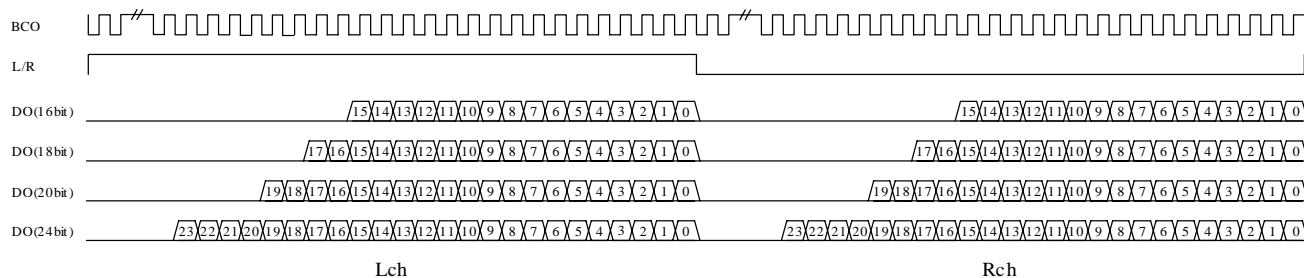

-3) The digital audio interface is made compatible with the following format with OPR register (\$00) and DAR register (\$04).

Format	BCI	BCO	OPR [5]	DAR [3:2]	MDR [3]	Available mode
Format1	-	64fs	1	*	0	N, E
Format2	32-96fs	64fs	0	0	0	N, E
Format3	64fs	BCI	0	1	0	E
	48fs		0	2		
			0	3		
Format4	-	64fs	0	*	1	E

N=KP2 standard mode
E=KP2V extended mode

Format1

Use this format when digital audio input is not used.

Format2

Use this format when digital audio input is used.

BCI is able to accept any frequency between including 96fs from 32fs, while BCO outputs only 64 fs. BCI, SDSY and DI signals must be synchronized with XI clock.

Format3

Use this format when digital audio input is used.

BCI input signal is passed to the BCO output, being inverted.

SDSY input signal is passed to the L/R output, being delayed by 2.5 clocks of BCI.

BCI, SDSY and DI signals must be synchronized with XI clock.

Format4

This format is used to interface with the A/D converter which outputs data MSB justified.

Connect BCO pin of this LSI to the bit clock input pin of the A/D converter, L/R pin to LR clock input pin of the converter, and DI pin to data output pin of the converter.

BCO outputs 64 fs without regarding to the value of DAR[3:2].

Keep the pins BCI and SDSY open.

The format 4 is as described below.

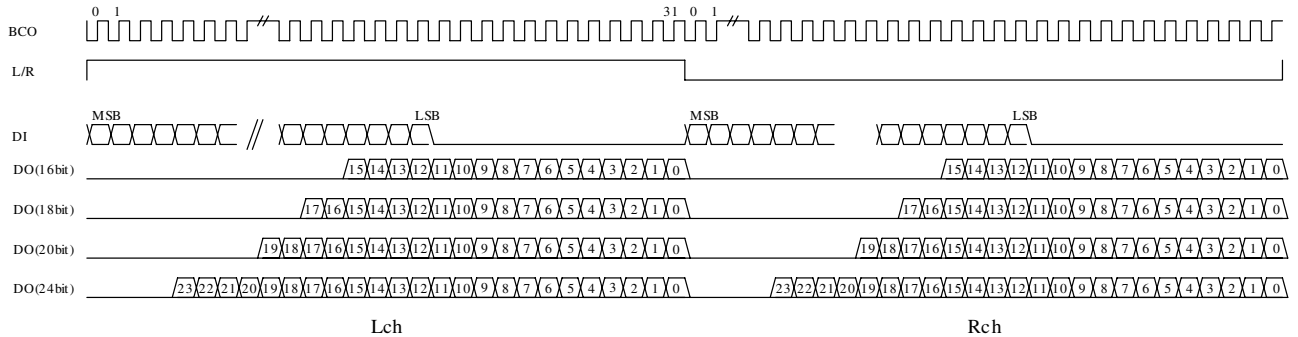

- 4) Length of data word of the digital audio signal can be set by the DAR register (\$04) to 16, 18, 20 or 24 bits (only in KP2V extended mode). When the data word is 24 bit long, only upper 20 bits are used for processing internal signal.

Length of inputted word	DAR [5:4]	Length of outputted word	DAR [1:0]
16bit	0	16bit	0
18bit	1	18bit	1
20bit	2	20bit	2
24bit	3	24bit	3

Note: In KP2 standard mode, both of the input and output word lengths are only 16 bits.

- 5) The through-mode can be selected by using DAR register (\$04) (only in KP2V extended mode).

In the through-mode ;

BCI input signal is passed to the BCO output, being inverted.

SDSY input signal is passed to the L/R output, being delayed by 2.5 clocks of BCI.

DI input signal is passed to the DO output, being delayed by 2.5 clocks of BCI.

When the sampling frequency is in the range from 64 kHz to 96 kHz, the input signal can be passed through this LSI without deteriorating, for example, the 24 bit data accuracy at the sampling frequency of 96 kHz.

The through-mode is enabled when the value of DAR[bit3:2] is “01”, “10” or “11”.

5. Microcomputer interface /CS, /SCK, CDI, CDO, DEPI

These are 8 bit serial interface for writing data into or reading data from internal registers of this device.
Do not write or read data into or from this device in 200 msec from the initial clear moment (rise moment of /IC).

-1) Writing data

Set the address of an internal register into the first byte, and data into the second byte.
Use the following format.

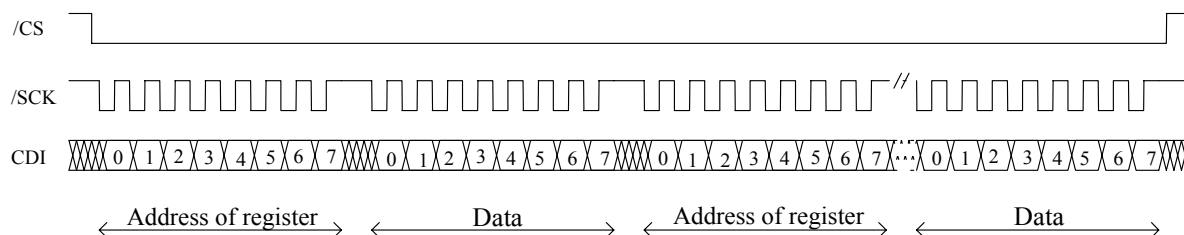

-2) Reading data (only in KP2V extended mode)

For reading data, only MLR register (\$10) is provided.
Use the following format.

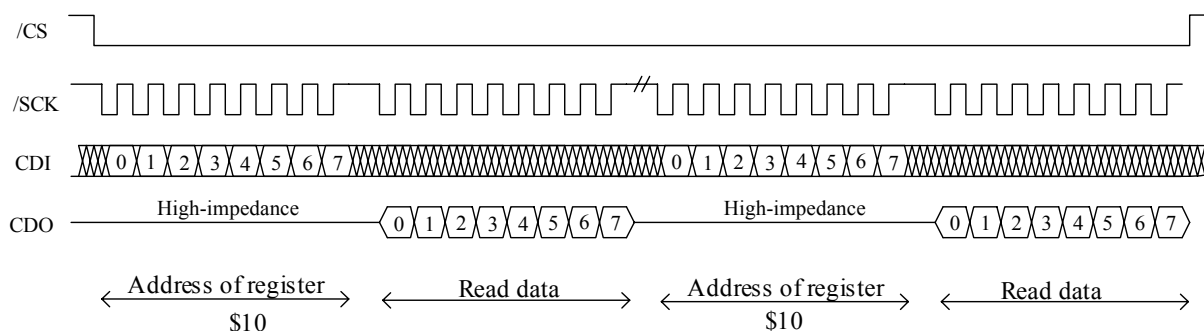

-3) DEPI

When DEPI is "H", de-emphasis is enabled regardless of the state of internal register.
When DEPI is "L", setting of OPR register (\$00) is valid.

6. Others P0 ,ZERO

-1) P0

P0 pin outputs the value of the register PHC[0](\$08). This value is outputted when OPR(\$00) has been set after the initial clear. This pin is in High-impedance state until OPR(\$00) is set.
This function is valid when MDR[0](\$1C) is '1'. When MDR[0](\$1C) is '0', this pin always outputs 'L' like YSS903 does.

-2) ZERO

When both of the digital audio outputs, L and R, have been "zero(0)" for the period equivalent to 511 samplings, the zero level detection function activates to make ZERO pin output 'L'. In other period, this pin is in 'H' state.
This value is outputted when OPR(\$00) has been set after the initial clear. This pin is in HZ state until OPR(\$00) is set.
This function is valid when MDR[1](\$1C) is '1'. When MDR[1](\$1C) is '0', this pin always outputs 'L' like YSS903 does.

OPERATIONS

Process flow chart

1. Karaoke program

Flow of signal in processing Karaoke audio signal in this LSI is as described by the following diagram.

The Karaoke program can be used in both KP2 standard mode or KP2V extended mode.

In KP2 standard mode, the same functions as those of KP2 can be used, and most of the registers of KP2V and KP2 are compatible with each other, except that the registers related to analog audio input and analog microphone echo output cannot be used because KP2V does not have these functions.

In KP2V extended mode, every function of the Karaoke program can be used.

Mono-echo, stereophonic echo, 3 D echo and super 3D echo provided in the evaluation board can be obtained by combining the following microphone echo/Reverb echo, microphone key control and/or microphone wide surround functions appropriately.

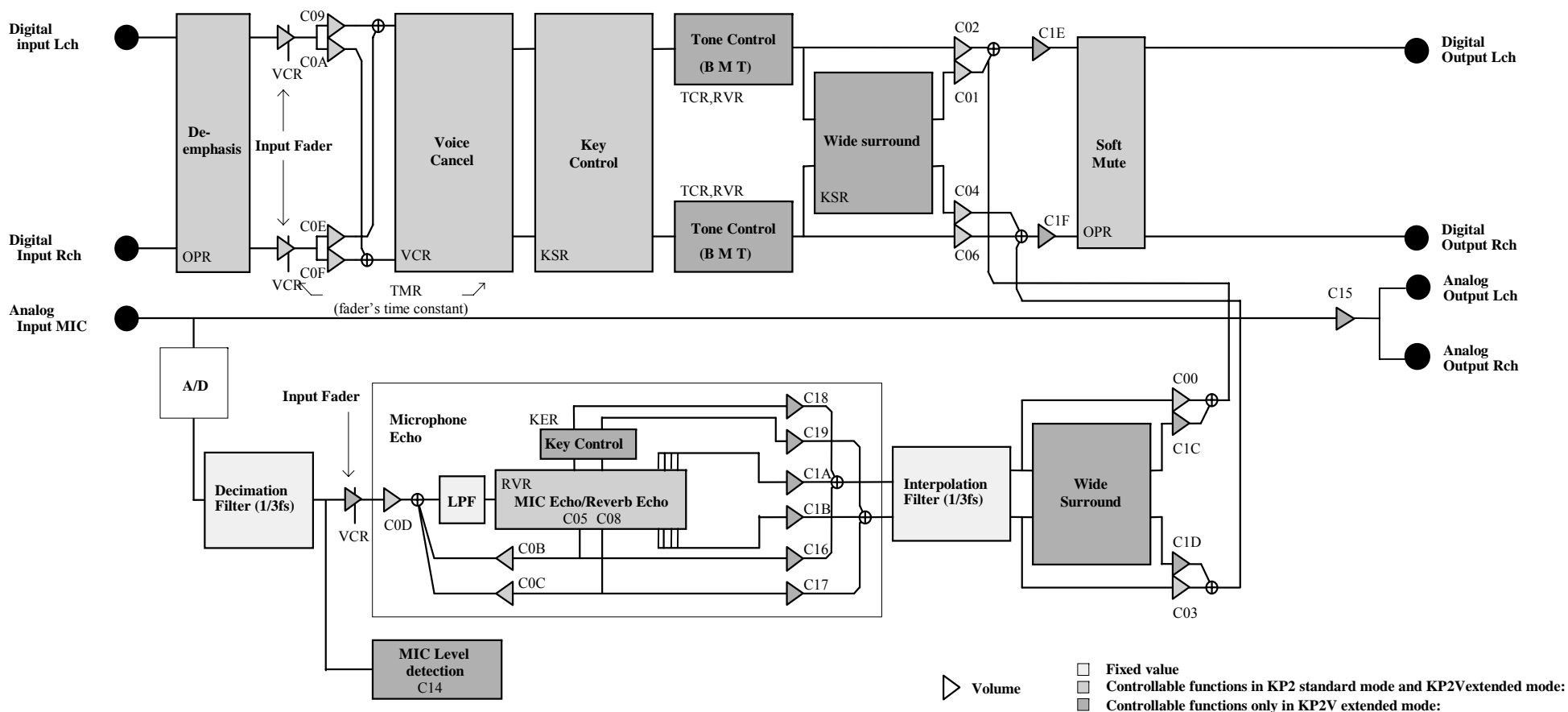

2. Movie and music program

Flow of signal in processing movie and music audio signal in this LSI is as follows

The movie or music program can be used in KP2V extended mode

The fifteen types of the surround mode provided in the evaluation board are obtained by combining the following tone control, initial reflection sound and/or wide surround functions appropriately.

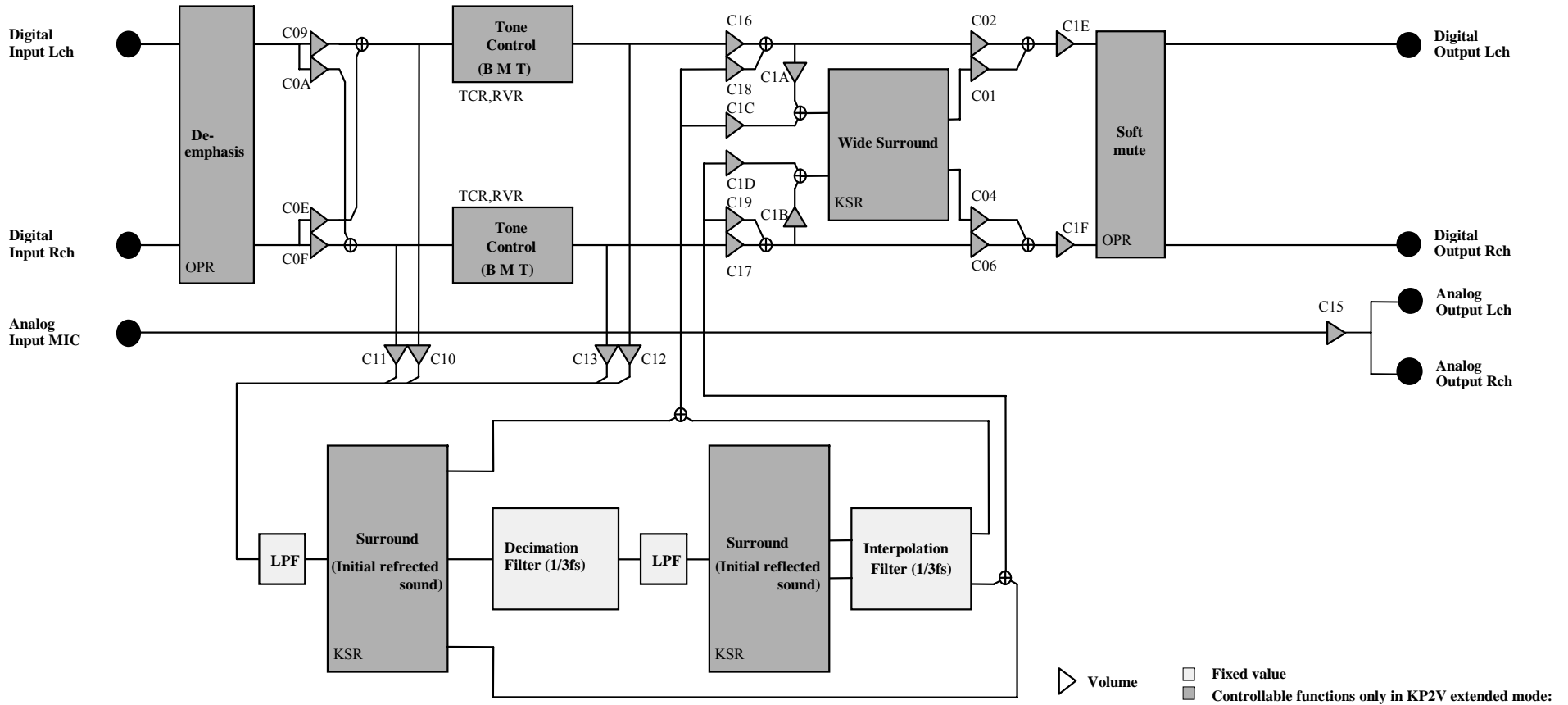

OPERATIONS OF FUNCTIONS

1. Karaoke program

Functions for processing the Karaoke audio signals are described here.

Function	Description	Control register Coefficient register	Controllable mode
De-emphasis	De-emphasizes audio input signal that has been emphasized. Specifies a sampling frequency and on/off of de-emphasis.	OPR[1] OPR[7:6]	N, E
Input Fader	Controls fade-in/out for audio input signal. Specifies fade-in/out for each channel after setting fade time (See Note.)	VCR[1:0] TMR[7:0]	N, E
Voice Cancel	Reduces mid-range signal of inputted audio signal that is located in the center of the sound field such vocal signal generated by stereophonic CD. Specifies voice cancel on/off after setting sampling frequency and fade time. (See Note.)	VCR[4] TMR[7:0] OPR[7:6]	N, E
Key Control	Changes key of inputted audio signal, and controls key shift for audio input signal. The amount of key shift must be specified.	KSR[4:0]	N, E
Tone Control	Controls tone of inputted audio signal in three frequency bands. Specifies the levels for bass (fc = 200 Hz), treble (fc = 5 kHz), and mid-tone (fc = 1 kHz) after selecting a sampling frequency.	TCR[7:0] RVR[3:0] OPR[7:6]	E
Surround	Applies wide surround to audio input signal. One of four types of surround modes is selected and Output levels for R and L channels are set individually based on the selected surround mode.	KSR[6:5] C01, C04	N, E
Microphone level detection	Detects and reads the level of signal input from microphone. Specifies the time constant for level detection.	MLR[7:0] C14	E
Microphone Echo	Applies echo to signal from microphone processed by setting delay and feedback. Specifies delay time, feedback level and output signal level for L/R.	C05, C08, C0B, C0C C16, C17, C00, C03	N, E
Stereo Echo	Expands echo by providing stereophonic output.	C1A, C1B	E
Reverberation Echo	Damps echo naturally by adding reverb function.	RVR[4]	E
Microphone key control	Applies microphone echo by subjecting signal inputted from microphone to key shift. Specifies the amount of key shift and output signal level for L/R.	KER[7:0] C18, C19	E
Microphone Wide surround	Applies surround to microphone echo to obtain expansion that is specific to wide surround. Specifies output signal level for L/R.	C1C, C1D	E
Soft Mute	Noiseless mute, Specifies on/off.	OPR[3]	N, E
Volume	Controls volume. Some of the functions can be set in either of KP2 standard mode or KP2V extended mode, some only in KP2V extended mode.	C02, C06, C09, C0A C0D, C0E, C0F, C15 C1E, C1F	N, E

Note: The fade time is applicable to the input fader and voice cancel functions.

2. Movie and music program

Functions for processing the movie and music signals are described here.
 The movie and music program can be used in KP2V extended mode.

Function	Description	Control register Coefficient register
De-emphasis	De-emphasizes audio input signal that has been emphasized. Specifies a sampling frequency and on/off of de-emphasis.	OPR[1] OPR[7:6]
Tone Control	Controls tone of inputted audio signal in three frequency bands. Specifies the levels for bass (fc = 200 Hz), treble (fc = 5 kHz), and mid-tone (fc = 1 KHz) after selecting a sampling frequency.	TCR[7:0] RVR[3:0] OPR[7:6]
Surround 1 (Initial reflected sound)	Applies surround that uses initial reflected sound synthesizing system to audio input signal. One of four types of surround modes is selected and Output levels for R and L channels are set individually based on the selected surround mode.	KSR[6:5] C10, C11, C12 C13, C18, C19
Wide Surround	Applies wide surround to audio input signal. One of two types of surround modes is selected and Output levels for R and L channels are set individually based on the selected surround mode.	KSR[7] C1A, C1B, C1C C1D, C01, C04
Soft Mute	Noiseless mute, Specifies on/off.	OPR[3]
Volume	Controls volume.	C02, C06, C09, C0A, C0E, C0F, C15, C16 C17, C1E, C1F

This LSI presents the features of sound field by using a combination of tone control, surround (initial reflected sound) and wide surround.
 The tone control determines frequency characteristics of the sound field.
 Initial reflected sound synthesis determines extent and depth of sound field to characterize a surround environment (concert hall and stadium).
 Wide surround determines size and extent of reverberation.

■ REGISTERS

This LSI is controlled by setting data into the registers.

The address, name and function of each register is outlined as follows.

Address	Name	Function
\$00	OPR	Controls internal operations.
\$01	KSR	Controls key and surround.
\$02	VCR	Controls input fader and voice cancel.
\$03	TMR	Controls fade time for input fader and voice cancel.
\$04	DAR	Controls digital audio I/O format.
\$05	TCR	Controls tone (bass, treble).
\$06	RVR	Controls tone (mid-range) and Reverb-echo.
\$07	KER	Controls key for microphone.
\$08	PHC	Port output register.
\$10	MLR	Reads microphone level.
\$1C	MDR	Switching KP2 standard/KP2V extension mode, and others.
\$20 ↓ \$3F	C00 ↓ C1F	Coefficient register (controls volume and delay.)
\$FA ↓ \$FF		Test register (Don't write any data)

* Writing is prohibited except for permitted address.

Controllable and uncontrollable registers (bits) vary according to the following modes.
The mode is specified as follows according to the status of bit 7 of MDR register(\$1C).

Code	Mode	MDR(\$1C)[bit 6]
N	KP2 standard mode	0
E	KP2V extended mode	1

1. Functions

Functions, default value and controllable mode are as shown below.

The default value is the value that is set at initial clear or the one obtained in other than the controllable mode.

-1) OPR(\$00): Control of internal operation

bit	Function	Default	Controllable mode
0	Unused (Set "1" here.)	1	-
1	Controlling De-emphasis 1 = De-emphasis is disabled. 0 = De-emphasis is enabled. Note: Whenever DEPI is "H", de-emphasis is enable regardless of the status of this bit.	1	N, E
2	Unused (Set "0" here.)	1	-
3	Controlling soft mute 1 = Soft mute is off (Fade-in at (1024/fs (sec)) 0 = Soft mute is on (Fade-out at (1024/fs (sec)) Note: fs = sampling frequency (Hz)	1	N, E
4	Controlling internal accumulator output clear on/off 1 = Internal accumulator output clear is on. 0 = Internal accumulator output clear is off (Normal operation).	1	N, E
5	Controlling sync mode 1 = Internal synchronization mode (Digital audio input signals (BCI, SDSY and DI) are not used.) 0 = External synchronization mode (Digital audio input signals (BCI, SDSY and DI) are used.)	1	N, E
6	Selecting sampling frequency b7 b6 0 0 = 37.8kHz 0 1 = 44.1kHz	1	N, E
7	1 0 = 32.0kHz 1 1 = 48.0kHz Note: The frequencies 32.0 kHz and 48.0 kHz are valid in KP2V extension mode.	0	E

-2) KSR(\$01) : Control of key and surround

bit	Function	Default	Controllable mode
0	Amount of key shift for audio signal key control (This function is valid on Karaoke program. For the correspondence between the setting value for key control and the amount of key shift, refer to the table below.)	0	N, E
1		0	
2		0	
3		0	
4		0	
5	Selecting a type of surround (wide surround) for Karaoke program, or a type of surround (initial reflected sound) for movie or music program. (For the Correspondence between the setting value and the surround type, refer to the table below.)	0	N, E
6		0	
7	Selecting a surround mode for wide surround (valid in movie and music mode) 0 = MODE0 1 = MODE1	0	E

Correspondence between the setting value for key control and the amount of key shift for audio signal

KSR			
bit 4-0	Amount of key shift	bit 4-0	Amount of key shift
0F	9-1/2 keys up	1F	1/4 key down
0E	1 octave up	1E	2/4 key down
0D	3-1/2 keys up	1D	3/4 key down
0C	3 keys up	1C	1 key down
0B	2-3/4 keys up	1B	1-1/4 keys down
0A	2-2/4 keys up	1A	1-2/4 keys down
09	2-1/4 keys up	19	1-3/4 keys down
08	2 keys up	18	2 keys down
07	1-3/4 keys up	17	2-1/4 keys down
06	1-2/4 keys up	16	2-2/4 keys down
05	1-1/4 keys up	15	2-3/4 keys down
04	1 key up	14	3 keys down
03	3/4 key up	13	3-1/2 keys down
02	2/4 key up	12	1 octave down
01	1/4 key up	11	7 keys down
00	No key shift	10	9-1/2 keys down

Correspondence between the surround type and surround selection bit

KSR		
bit 6 5	Wide Surround for Karaoke program	Surround for movie and music program (Initial reflected sound)
0 0	PSEUDO-STEREOPHONIC SOUND	HALL0 (See Note.)
0 1	LIVE	HALL1 (See Note.)
1 0	MOVIE	STADIUM
1 1	KARAOKE	ROCK CONCERT

Note: HALL0 → Concert hall that provides standard reverberation
 HALL1 → Concert hall that provides long reverberation

-3) VCR(\$02) : Control of input fader and voice cancel (valid for Karaoke program)

bit	Function	Default	Controllable mode
0	Controlling fade-in/out at digital audio input L channel 1 = Starting fade in 0 = Starting fade out Note: Before this bit is set, set fade time into TMR (\$03)	0	N, E
1	Controlling fade-in/out at digital audio input R channel 1 = Starting fade in 0 = Starting fade out Note: Before this bit is set, set fade time into TMR (\$03)	0	N, E
2	Unused (Set "0" here.)	0	-
3	Unused (Set "0" here.)	0	-
4	Controlling voice cancel on/off 1 = On (switching from through-path to voice-canceled path) 0 = Off (switching from voice-canceled path to through-path) Note: Before this bit is set, set cross fade time into TMR (\$03).	0	N, E
5	Fade-in/fade-out for microphone echo input 0 = Starting fade in 1 = Starting fade out Note: Fade time = 1024/fs (sec)	0	E
6	Unused (Set "0" here.)	0	-
7	Unused (Set "0" here.)	0	-

-4) TMR(\$03) : Control of fade time for input fader and voice cancel (valid for Karaoke program)

bit	Function	Default	Controllable mode
0	Fade time for input fader and voice cancel Fade time = 1024/fs (sec) when TMR=00h 1048576/fs/TMR (sec) when TMR=other than 00h Note: fs = sampling frequency	0	N, E
1		0	
2		0	
3		0	
4		0	
5		0	
6		0	
7		0	

-5) DAR(\$04) : Control of digital audio I/O format

bit	Function	Default	Controllable mode
0	Selecting digital audio output data word length b1 b0 0 0 = 16 bits 0 1 = 18 bits 1 0 = 20 bits 1 1 = 24 bits	0	E
1		0	
2	This function is valid when bit 5 of OPR(\$00) = 0. When this bit = 1, the digital audio output synchronizes with internal clock (64 fs). b3 b2 0 0 = Synchronizing with internal clock (64 fs) 0 1 = Synchronizing with BCI (64 fs) 1 0 = Synchronizing with BCI (48 fs) 1 1 = Synchronizing with BCI (32 fs)	0	E
3		0	
4	Selecting digital audio input data word length b5 b4 0 0 = 16bit 0 1 = 18bit 1 0 = 20bit 1 1 = 24bit	0	E
5		0	
6	Selecting an output to digital audio output pin (BCO, L/R and DO) b7 b6 0 0 = Normal (Internally processed data are outputted.) 0 1 = BCO, L/R and DO are fixed to "L". 1 0 = BCI, SDDY and DI are through-outputted. (For the details, refer to 4-5) in Page 9.) 1 1 = Inhibited	0	E
7		0	

-6) TCR(\$05) : Control of tone (bass, treble)

bit	Function	Default	Controllable mode
0	Controlling level of bass (fc = 200 Hz) (fc = cutoff frequency) (For the correspondence between the setting value and the level, refer to the table below.)	0	E
1		0	
2		0	
3		0	
4	Controlling level of treble (fc = 5 kHz) (fc = cutoff frequency) (For the correspondence between the setting value and the level, refer to the table below.)	0	E
5		0	
6		0	
7		0	

-7) RVR(\$06) : Control of tone (mid-range) and Reverb echo

bit	Function	Default	Controllable mode
0	Controlling level of mid-tone (fc = 1 kHz) (fc = center frequency) (For the correspondence between the setting value and the level, refer to the table below.)	0	E
1		0	
2		0	
3		0	
4	Controlling reverb on/off (valid for Karaoke program) 0 = Reverb off 1 = Reverb on	0	E
5	Selection of low pass filter for microphone echo 0 = Cut off frequency equivalent to that of YSS903 (Standard) 1 = Cut off frequency higher than that of YSS903 (Wide)	0	E
6	Unused (Set "0" here.)	0	-
7	Unused (Set "0" here.)	0	-

Correspondence between the setting value and the level

TCR				RVR	
bit	Level of	bit	Level of	bit	Level of
3 - 0	bass	7 - 4	treble	3 - 0	mid-tone
7	Inhibited	7	Inhibited	7	Inhibited
6	Inhibited	6	Inhibited	6	Inhibited
5	+10dB	5	+10dB	5	+10dB
4	+8dB	4	+8dB	4	+8dB
3	+6dB	3	+6dB	3	+6dB
2	+4dB	2	+4dB	2	+4dB
1	+2dB	1	+2dB	1	+2dB
0	0dB	0	0dB	0	0dB
F	-2dB	F	-2dB	F	-2dB
E	-4dB	E	-4dB	E	-4dB
D	-6dB	D	-6dB	D	-6dB
C	-8dB	C	-8dB	C	-8dB
B	-10dB	B	-10dB	B	-10dB
A	Inhibited	A	Inhibited	A	Inhibited
9	Inhibited	9	Inhibited	9	Inhibited
8	Inhibited	8	Inhibited	8	Inhibited

-8) KER(\$07) : Control of Key for microphone

bit	Function	Default	Controllable mode
0	Amount of key shift for controlling microphone key at L channel (This function is valid on Karaoke program. For the correspondence between the setting value and the amount of key shift, refer to the table below.)	0	E
1		0	
2		0	
3		0	
4	Amount of key shift for controlling microphone key at R channel (This function is valid on Karaoke program. For the correspondence between the setting value and the amount of key shift, refer to the table below.)	0	E
5		0	
6		0	
7		0	

Correspondence between the setting value and the amount of key shift

KER			
bit 3 - 0	Amount of key shift at L channel	bit 7 - 4	Amount of key shift at R channel
7	Inhibited	7	Inhibited
6	Inhibited	6	Inhibited
5	1 octave up	5	1 octave up
4	3-1/2 keys up	4	3-1/2 keys up
3	2 keys up	3	2 keys up
2	20 cents up	2	20 cents up
1	10 cents up	1	10 cents up
0	No key shift	0	No key shift
F	10 cents down	F	10 cents down
E	20 cents down	E	20 cents down
D	2 keys down	D	2 keys down
C	3-1/2 keys down	C	3-1/2 keys down
B	1 octave down	B	1 octave down
A	Inhibited	A	Inhibited
9	Inhibited	9	Inhibited
8	Inhibited	8	Inhibited

-9) PHC(\$08) : Output port register

bit	Function	Default	Controllable mode
0	This value is outputted at PO pin. This function is enabled when MDR[0](\$1C) = '1'. When it is '0', PO pin is always at 'L' state.	0	E
1	Unused (Set "0" here.)	0	-
2	Unused (Set "0" here.)	0	-
3	Unused (Set "0" here.)	0	-
4	Unused (Set "0" here.)	0	-
5	Unused (Set "0" here.)	0	-
6	Unused (Set "0" here.)	0	-
7	Unused (Set "0" here.)	0	-

-10) MLR(\$10) : Microphone level read register (valid for Karaoke program)

bit	Function	Default	Controllable mode
0	Detected microphone level (unsigned binary of 8bits)	0	E
1		0	
2		0	
3		0	
4		0	
5		0	
6		0	
7		0	

-11) MDR(\$1C) : Switching KP2 standard mode/KP2V extended mode, and others

bit	Function	Default	Controllable mode
0	Specifies whether the value of PHC[0](\$08) is outputted at PO pin. 0 = Not outputted (The same as YSS903) 1 = Outputted	0	E
1	Specifies whether the result of zero level detection is outputted at ZERO pin. 0 = Not outputted (The same as YSS903) 1 = Outputted	0	E
2	Selects band width for microphone echo 0 = Sampling frequency is 8 kHz. (The same as YSS903) 1 = Sampling frequency is 12 kHz.	0	E
3	Connection with MSB justified data output A/D converter 0 = Direct connection not allowed (The same as YSS903) 1 = Direct connection allowed	0	E
4	Selecting karaoke/movie & music program 0 = Karaoke program 1 = Movie music program (When switching the program, be sure to mute, change the setting of coefficient register and this bit, and then release the mute when 250 ms has passed.)	0	E
5	Unused	0	-
6	Switching KP2 standard mode/KP2V extended mode 0 = KP2 standard mode 1 = KP2V extended mode	0	N, E
7	Unused (Set "0" here.)	0	-

-12) C**(\$20 to \$3F) : Coefficient registers (Controlling volume and delay)

bit 7	bit 6	bit 5	bit 4	bit 3	bit 2	bit 1	bit 0
C ₇	C ₆	C ₅	C ₄	C ₃	C ₂	C ₁	C ₀

C₇-C₀:Sets volume coefficient or delay coefficient

- For the addresses of the registers their functions for Karaoke and movie & music programs, refer to the following table and flow chart described in "OPERATIONS" section.
- For the relation between the setting value of coefficient, and volume level and delay time, refer to the formula shown later.
- When the coefficient registers controllable only in KP2V extended mode is used in the KP2 standard mode, the following preset values are used as their coefficient of address, and their setting values are not used.
- The values of the registers are indefinite immediately after turning on the power, be sure to set the register values in the controllable mode before releasing the mute.

Name, function, preset value and controllable mode of the addresses of the coefficient register for Karaoke program

Register address	Name	Function	Preset value	Controllable mode
\$20	C00	Echo L channel output mixing level	-	N, E
\$21	C01	Surround L channel output mixing level	-	N, E
\$22	C02	Audio L channel output mixing level	-	N, E
\$23	C03	Echo R channel output mixing level	-	N, E
\$24	C04	Surround R channel output mixing level	-	N, E
\$25	C05	Microphone echo L channel delay	-	N, E
\$26	C06	Audio R channel output mixing level	-	N, E
\$27	-	Unused	-	-
\$28	C08	Microphone echo R channel delay	-	N, E
\$29	C09	Digital input L - L channel mixing level	-	N, E
\$2A	C0A	Digital input L - R channel mixing level	-	N, E
\$2B	C0B	Microphone echo L channel feedback level	-	N, E
\$2C	C0C	Microphone echo R channel feedback level	-	N, E
\$2D	C0D	Microphone echo input level	-	N, E
\$2E	C0E	Digital input R - L channel mixing level	-	N, E
\$2F	C0F	Digital input R - R channel mixing level	-	N, E
\$30	-	Unused	-	-
\$31	-	Unused	-	-
\$32	-	Unused	-	-
\$33	-	Unused	-	-
\$34	C14	Time constant for microphone level detection	\$00	E
\$35	C15	Microphone direct sound output mixing level	\$1F	E
\$36	C16	Microphone echo L channel mixing level	\$7F	E
\$37	C17	Microphone echo R channel mixing level	\$7F	E
\$38	C18	Microphone key control L channel mixing level	\$00	E
\$39	C19	Microphone key control R channel mixing level	\$00	E
\$3A	C1A	Stereo-phonic echo L channel mixing level	\$00	E
\$3B	C1B	Stereo-phonic echo R channel mixing level	\$00	E
\$3C	C1C	Microphone echo wide surround L channel mixing level	\$00	E
\$3D	C1D	Microphone echo wide surround R channel mixing level	\$00	E
\$3E	C1E	L channel total output level	\$7F	E
\$3F	C1F	R channel total output level	\$7F	E

Name, function, and controllable mode of the addresses of the coefficient register for movie and music program

Register address	Name	Function	Controllable mode
\$20	-	Unused	-
\$21	C01	Wide Surround L channel output mixing level	E
\$22	C02	Audio & surround (initial reflected sound) L channel output mixing level	E
\$23	-	Unused	-
\$24	C04	Wide Surround R channel output mixing level	E
\$25	-	Unused	-
\$26	C06	Audio & surround (initial reflected sound) R channel output mixing level	E
\$27	-	Unused	-
\$28	-	Unused	-
\$29	C09	Digital input L - L channel mixing level	E
\$2A	C0A	Digital input L - R channel mixing level	E
\$2B	-	Unused	-
\$2C	-	Unused	-
\$2D	-	Unused	-
\$2E	C0E	Digital input R - L channel mixing level	E
\$2F	C0F	Digital input R - R channel mixing level	E
\$30	C10	Surround (initial reflected sound) input 1 L channel mixing level	E
\$31	C11	Surround (initial reflected sound) input 1 R channel mixing level	E
\$32	C12	Surround (initial reflected sound) input 2 L channel mixing level	E
\$33	C13	Surround (initial reflected sound) input 2 R channel mixing level	E
\$34	-	Unused	-
\$35	C15	Microphone direct sound output mixing level	E
\$36	C16	Audio L channel output mixing level	E
\$37	C17	Audio R channel output mixing level	E
\$38	C18	Surround (initial reflected sound) L channel mixing level	E
\$39	C19	Surround (initial reflected sound) R channel mixing level	E
\$3A	C1A	Wide Surround input 1 L channel mixing level	E
\$3B	C1B	Wide Surround input 1 R channel mixing level	E
\$3C	C1C	Wide Surround input 2 L channel mixing level	E
\$3D	C1D	Wide Surround input 2 R channel mixing level	E
\$3E	C1E	L channel total output level	E
\$3F	C1F	R channel total output level	E

Correspondence between setting value and level of C15

C15					
bit 7-0	Level	bit 7-0	Level	bit 7-0	Level
00	0 dB	0C	-18.0dB	18	-36.0dB
01	-1.5dB	0D	-19.5dB	19	-37.5dB
02	-3.0dB	0E	-21.0dB	1A	-39.0dB
03	-4.5dB	0F	-22.5dB	1B	-40.5dB
04	-6.0dB	10	-24.0dB	1C	-42.0dB
05	-7.5dB	11	-25.5dB	1D	-43.5dB
06	-9.0dB	12	-27.0dB	1E	-45.0dB
07	-10.5dB	13	-28.5dB	1F	MUTE
08	-12.0dB	14	-30.0dB	20	Inhibited
09	-13.5dB	15	-31.5dB		
0A	-15.0dB	16	-33.0dB	FF	Inhibited
0B	-16.5dB	17	-34.5dB		

Relation between setting value of coefficient registers (\$20 to \$3F), and volume level and delay time

Delay time (C05, C08)

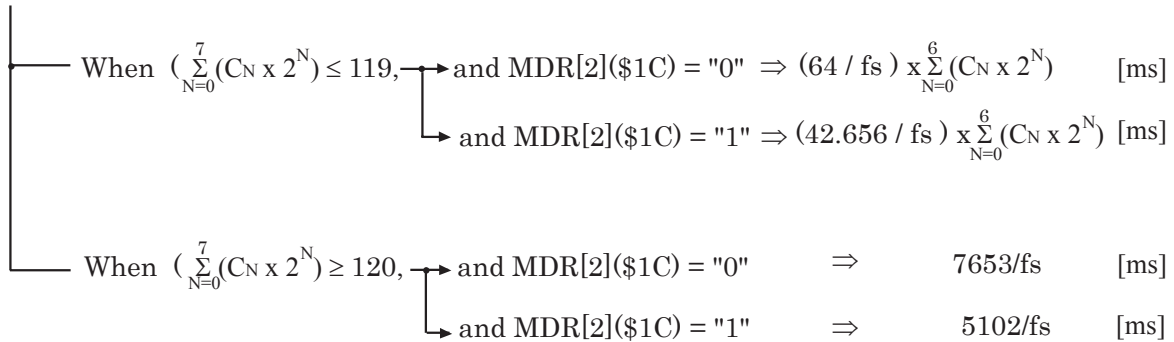

However, when the bit 4 of the Reverb echo ON(RVR(\$06) is "1",
it is necessary to meet with $\sum_{N=0}^7 (C_N \times 2^N) \leq 102$

Other volume level

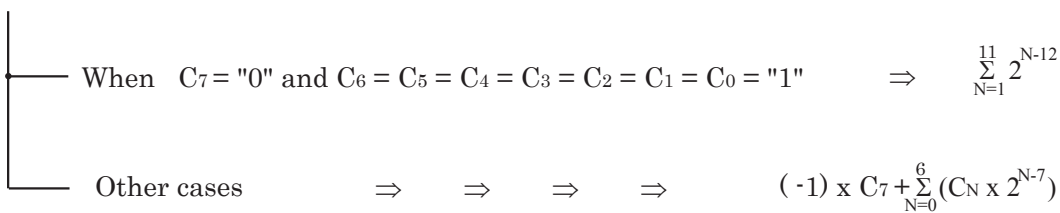

Note1: fs shows sampling frequency [kHz].

Note2: C₇, C₆, C₅, C₄, C₃, C₂, C₁ and C₀ show each bits (bit7-bit0) of a register which are set volume value.

■ ELECTRICAL CHARACTERISTICS

1. Absolute maximum ratings

Item	Code	Rating	Unit
Power source voltage	AVDD,DVDD	-0.3 to 7.0	V
Digital input voltage	VI	-0.5 to DVDD + 0.5	V
Analog input voltage	VI	-0.5 to AVDD + 0.5	V
Operating temperature	Top	0 to 70	°C
Storage temperature	Tstg	-50 to 125	°C

2. Recommended operating conditions

Item	Code	Minimum	Typical	Maximum	Unit
Digital power source voltage	DVDD	4.75	5.00	5.25	V
Analog power source voltage	AVDD	4.50	5.00	5.25	V
Operating temperature	Top	0	25	70	°C

3. DC characteristics (Conditions: Ta = 0 to 70 °C, DVDD = 5.0 +/- 0.25 V)

Item	Code	Condition	Minimum	Typical	Maximum	Unit
Power source current	IDD	VDD = 5.0V			80	mA
Input voltage H level (1)	VIH1	(See Note 1)	2.0			V
Input voltage H level (2)	VIH2	(See Note 2)	3.5			V
Input voltage L level	VIL				0.8	V
Input leakage current	ILK		-10		10	μA
Output voltage H level	VOH	IOH = -0.4mA	VDD-1.0			V
Output voltage L level	VOL	IOL = 1.6mA			0.4	V

Notes:

- (1) Applies to input pins other than XISEL, DO and PO.
- (2) Applies to input pins XISEL, DO and PO.

4. Analog characteristics (Conditions : Ta = 25 °C, DVDD=AVDD = 5.0 V)

Item	Code	Condition	Minimum	Typical	Maximum	Unit
Analog input voltage	VIA	(See Note 1)		(See Note 2)		V
Analog output voltage	VOA	(See Note 3)		2.8		V
A DC • Total harmonic distortion	THD+N	(See Note 5,6) 0 dB		0.04	0.2	%
• Dynamic range	DR	(See Note 4,5,6) -60 dB	75	80		dB
Analog through						
• Total harmonic distortion	THD+N	(See Note 6,7) 0 dB		0.005	0.02	%
• Dynamic range	DR	(See Note 4,6,7) -60 dB	90	95		dB

Notes: Input signal frequency is 1KHz.

- (1) Peak to peak value. Applies to MICIN pin
- (2) Any voltage can be used if input resistor attached externally to MICIN is selected properly
 $V_{IA} = R/9.4K$, When value of a resistor was shown with R,
- (3) Peak to peak value. Applies to AOL and AOR pins. The output voltage is in proportion to AVDD.
- (4) Uses IHF-A
- (5) The signal is outputted through MICIN inputs to digital outputs via Volume.
- (6) Input resistor attached externally to MICIN : 47 kΩ. 0 dB = 4.65 Vpp
- (7) The signal is outputted through MICIN inputs to AOL and AOR via volume.

5. AC characteristics (Conditions : Ta = 0 to 70 °C, DVDD = 5.0 +/- 0.25 V)

Item	Code	Minimum	Typical	Maximum	Unit
XI	Input frequency	fc (See Note 1)	12.0	18.5 (See Note 3)	MHz
		fc (See Note 2)	8.0	12.5 (See Note 4)	MHz
XI	Duty factor	Rc	50		%
BCI	Frequency	fBC	1.0	4.7 (See Note 5)	MHz
BCI	On/off time	tBO	100 (See Note 6)		ns
	Transition time	tBT		20	ns
DI, SDSY	Setup time	tDS	80 (See Note 7)		ns
	Hold time	tDH	80 (See Note 7)		ns
DO, L/R	Access time	tD	-20	20	ns
/CS	Setup time	tCS	1/50fs (See Note 8)		s
/SCK	On/off time	tSO	1/50fs (See Note 8)		s
/CS, /SCK	Transition time	tCT		1/150fs(See Note 8)	s
CDI	Setup time	tSS	1/100fs(See Note 8)		s
	Hold time	tSH	1/100fs(See Note 8)		s
CDO	Access time	tCD	220	600	ns
/IC	Hold time	tIX (See Note 9)	2		ms
		tIL(See Note 10)	100		μs

Notes:

- (1) XI = 384 fs (See Note 8.)
- (2) XI = 256 fs (See Note 8.)
- (3) 37 MHz in through-mode
- (4) 25 MHz in through-mode
- (5) 6.2 MHz in through-mode
- (6) 70 ns in through-mode
- (7) 50 ns in through-mode
- (8) fs : sampling frequency
- (9) Just after turn on the power
- (10) In operation

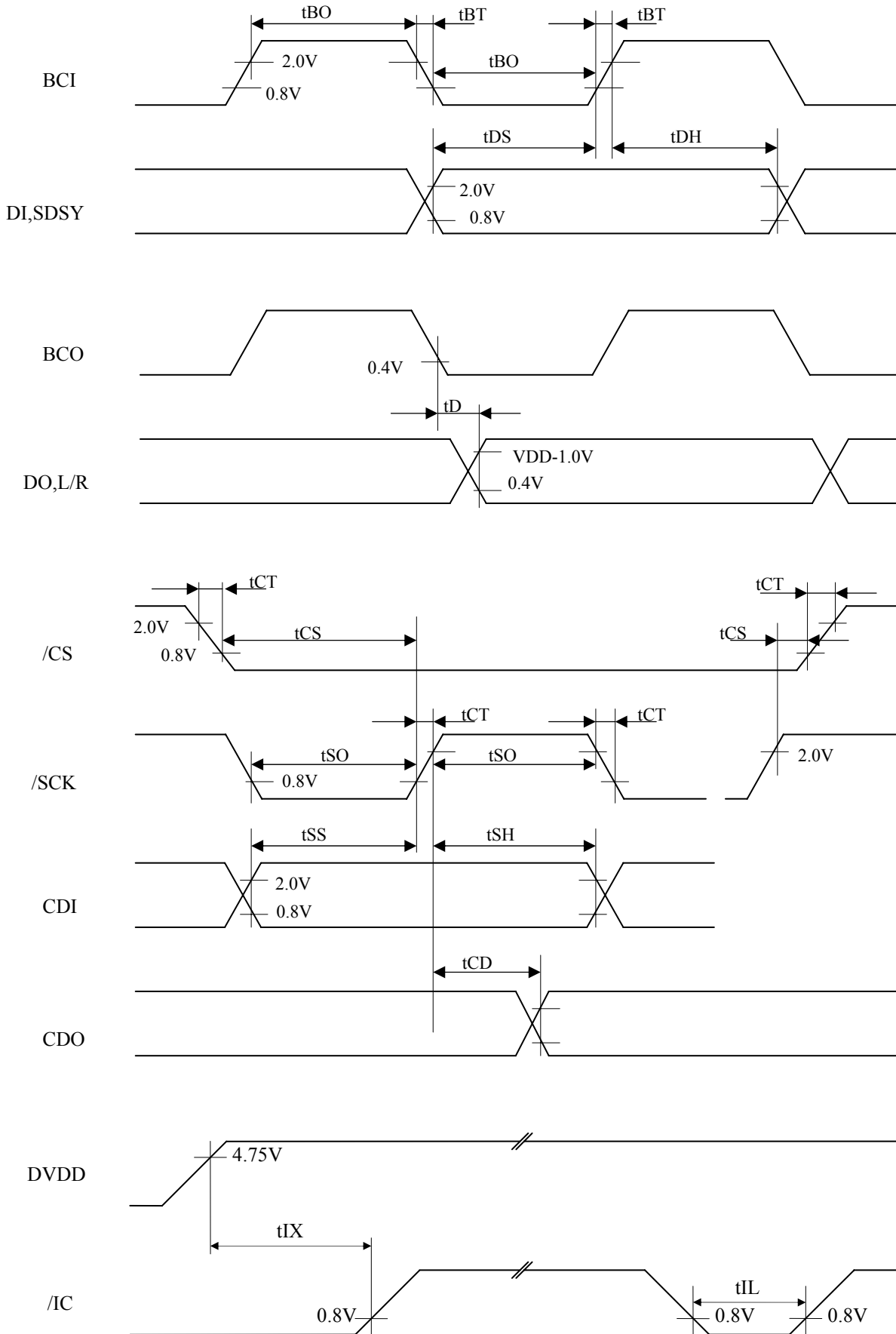

A procedure to change Normal mode to Through-mode

Normal mode means that it can apply the sound effect using internal DSP function and the sampling frequency is between 32kHz and 48kHz in this mode.

Through-mode means that the digital input data fed to YSS915 is bypassed to digital output pin without processing by DSP and the sampling frequency is 64kHz to 96kHz.

For example, when the sampling frequency is changed from 48kHz(called fs-single) to 96kHz(called fs-double), master clock frequency fed to XI pin of YSS915 may be changed according to the fs(sampling frequency).

In this case please refer to the following procedure.

A. Change Normal mode (fs-single) to Through-mode (fs-double)

1. Mute Analog output of the product
2. Set /IC="0" of YSS915
3. Change the master clock frequency (XI of YSS915) from "single" to "double"
4. Wait 2msec or more
5. Set /IC="1"
6. Set the parameters from the microprocessor to YSS915 as followed
 - opr [7:0] = 8'bx00x0x1
 - mdr [7:0] = 8'b01100000
 - dar [7:0] = 8'b10xx01xx or 8'b10xx10xx or 8'b10xx11xx
 - x means don't care
7. Disable to mute Analog output of the product

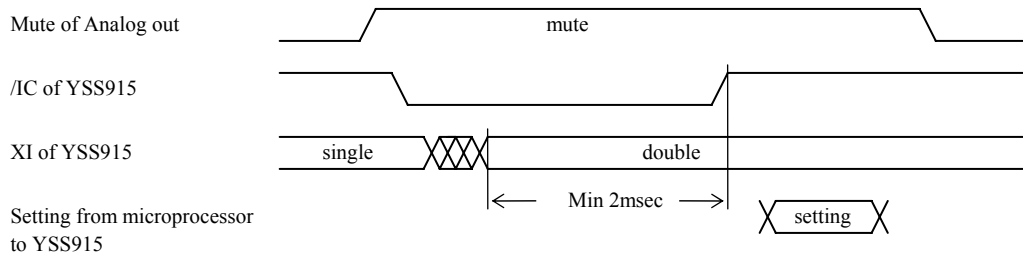

B. Change Through-mode (fs-double) to Normal mode (fs-single)

1. Mute Analog output of the product
2. Set /IC="0" of YSS915
3. Change the master clock frequency (XI of YSS915) from "double" to "single"
4. Wait 2msec or more
5. Set /IC="1"
6. Set the parameters from the microprocessor to YSS915 as the same way after power on

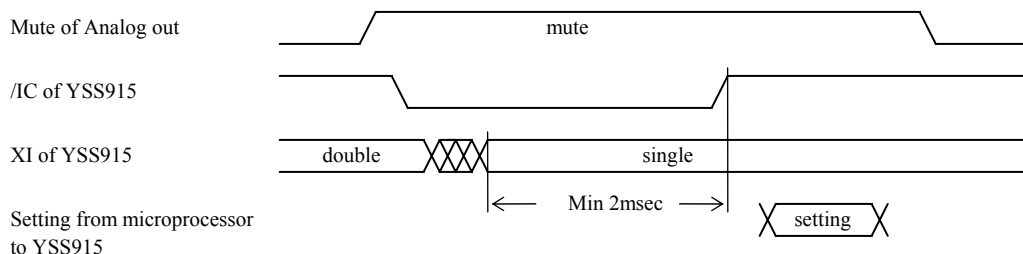

■ **EXTERNAL DIMENSIONS**

C-PK28MP-1

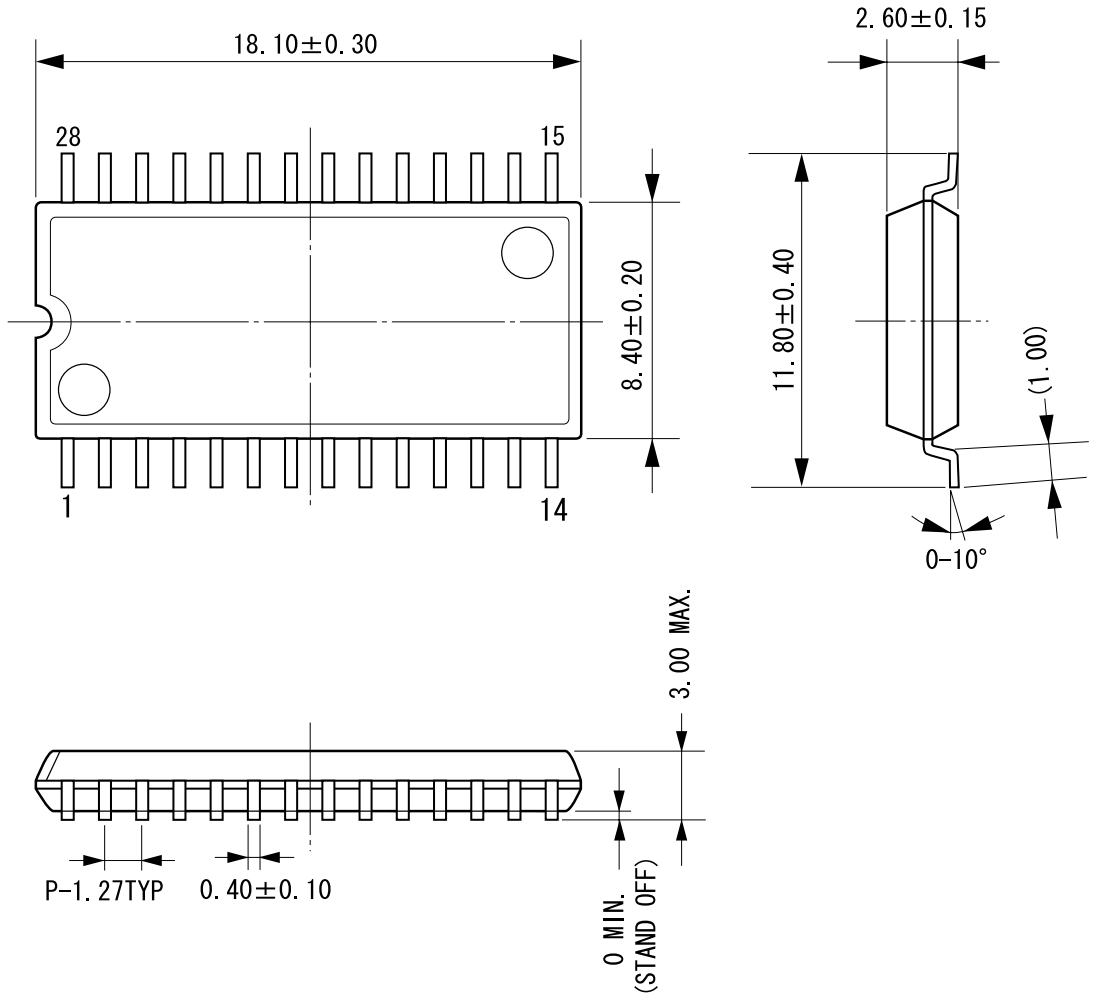

端子厚さ : 0.15 ± 0.10
(LEAD THICKNESS)

モールドコーナー形状は、この図面と若干異なるタイプもあります。
カッコ内の寸法値は参考値です。
モールド外形寸法はバリを含みません。
単位 : mm

The shape of the molded corner may slightly differ from the shape in this diagram.
The figure in the parentheses () should be used as a reference.
Plastic body dimensions do not include resin burr.
UNIT: mm

注) 表面実装LSIは、保管条件、及び半田付けについての特別な配慮が必要です。
詳しくはヤマハ代理店までお問い合わせください。
Note: The storage and soldering of LSIs for surface mounting need special consideration.
For detailed information, please contact your local Yamaha agent.

IMPORTANT NOTICE

1. YAMAHA RESERVES THE RIGHT TO MAKE CHANGES TO ITS PRODUCTS AND TO THIS DOCUMENT WITHOUT NOTICE. THE INFORMATION CONTAINED IN THIS DOCUMENT HAS BEEN CAREFULLY CHECKED AND IS BELIEVED. HOWEVER, YAMAHA SHALL ASSUME NO RESPONSIBILITIES FOR INACCURACIES AND MAKE NO COMMITMENT TO UPDATE OR TO KEEP CURRENT THE INFORMATION CONTAINED IN THIS DOCUMENT.
2. THESE YAMAHA PRODUCTS ARE DESIGNED ONLY FOR COMMERCIAL AND NORMAL INDUSTRIAL APPLICATIONS, AND ARE NOT SUITABLE FOR OTHER USES, SUCH AS MEDICAL LIFE SUPPORT EQUIPMENT, NUCLEAR FACILITIES, CRITICAL CARE EQUIPMENT OR ANY OTHER APPLICATION THE FAILURE OF WHICH COULD LEAD TO DEATH, PERSONAL INJURY OR ENVIRONMENTAL OR PROPERTY DAMAGE. USE OF THE PRODUCTS IN ANY SUCH APPLICATION IS AT THE CUSTOMER'S OWN RISK AND EXPENSE.
3. YAMAHA SHALL ASSUME NO LIABILITY FOR INCIDENTAL, CONSEQUENTIAL OR SPECIAL DAMAGES OR INJURY THAT MAY RESULT FROM MISAPPLICATION OR IMPROPER USE OR OPERATION OF THE PRODUCT.
4. YAMAHA MAKES NO WARRANTY OR REPRESENTATION THAT THE PRODUCTS ARE SUBJECT TO INTELLECTUAL PROPERTY LICENSE FROM YAMAHA OR ANY THIRD PARTY, AND YAMAHA MAKES NO WARRANTY OR REPRESENTATION OF NON-INFRINGEMENT WITH RESPECT TO THE PRODUCTS. YAMAHA SPECIFICALLY EXCLUDES ANY LIABILITY TO THE CUSTOMER OR ANY THIRD PARTY ARISING FROM OR RELATED TO THE PRODUCTS INFRINGEMENT OF ANY THIRD PARTY'S INTELLECTUAL PROPERTY RIGHTS, INCLUDING THE PATENT, COPYRIGHT, TRADEMARK OR TRADE SECRET RIGHTS OF ANY THIRD PARTY.
5. EXAMPLES OF USE DESCRIBED HEREIN ARE MERELY TO INDICATE THE CHARACTERISTICS AND PERFORMANCE OF PRODUCTS. YAMAHA SHALL ASSUME NO RESPONSIBILITY FOR ANY INTELLECTUAL PROPERTY CLAIMS OR OTHER PROBLEMS THAT MAY RESULT FROM APPLICATIONS BASED ON THE EXAMPLES DESCRIBED HEREIN. YAMAHA MAKES NO WARRANTY WITH RESPECT TO THE PRODUCTS, EXPRESS OR IMPLIED, INCLUDING, BUT NOT LIMITED TO THE WARRANTIES OF MERCHANTABILITY, FITNESS FOR A PARTICULAR USE AND TITLE.
6. YAMAHA MAKES EVERY EFFORT TO IMPROVE THE QUALITY AND RELIABILITY OF ITS PRODUCTS. HOWEVER, ALL SEMICONDUCTOR PRODUCTS FAIL WITH SOME PROBABILITY. THEREFORE, YAMAHA REQUIRES THAT SUFFICIENT CARE BE GIVEN TO ENSURING SAFE DESIGN IN CUSTOMER PRODUCTS SUCH AS REDUNDANT DESIGN, ANTI-CONFLAGRATION DESIGN, AND DESIGN FOR PREVENTING MALFUNCTION IN ORDER TO PREVENT ACCIDENTS RESULTING IN INJURY OR DEATH, FIRE OR OTHER SOCIAL DAMAGE FROM OCCURRING AS A RESULT OF PRODUCT FAILURE.
7. INFORMATION DESCRIBED IN THIS DOCUMENT: APPLICATION CIRCUITS AND ITS CONSTANTS AND CALCULATION FORMULAS, PROGRAMS AND CONTROL PROCEDURES ARE PROVIDED FOR THE PURPOSE OF EXPLAINING TYPICAL OPERATION AND USAGE. THEREFORE, PLEASE EVALUATE THE DESIGN SUFFICIENTLY AS WHOLE SYSTEM UNDER THE CONSIDERATION OF VARIOUS EXTERNAL OR ENVIRONMENTAL CONDITIONS AND DETERMINE THEIR APPLICATION AT THE CUSTOMER'S OWN RISK. YAMAHA SHALL ASSUME NO RESPONSIBILITY FOR CLAIMS, DAMAGES, COSTS AND EXPENSES CAUSED BY THE CUSTOMER OR ANY THIRD PARTY, OWING TO THE USE OF THE ABOVE INFORMATION.

Notice The specifications of this product are subject to improvement changes without prior notice.

AGENT

YAMAHA CORPORATION

Address inquiries to:
Semiconductor Sales & Marketing Department

- Head Office 203, Matsunokijima, Iwata,
Shizuoka, 438-0192, Japan
Tel. +81-539-62-4918 Fax. +81-539-62-5054
- Tokyo Office 2-17-11, Takanawa, Minato-ku,
Tokyo, 108-8568, Japan
Tel. +81-3-5488-5431 Fax. +81-3-5488-5088
- Osaka Office 3-12-12, Minami Senba, Chuo-ku,
Osaka City, Osaka, 542-0081, Japan
Tel. +81-6-6252-6221 Fax. +81-6-6252-6229