

## General Description

Conexant's CX23754 is a low-power, 102dB Signal-to-Noise Ratio (SNR), High Definition (HD) audio Coder-Decoder (CODEC) that delivers high-quality audio for the mobile Personal Computer (PC) market, including notebooks, ultrabooks, and tablets.

Compliant with Intel's *HD Audio Specification 1.0a*, the CX23754 has audio fidelity that exceeds Microsoft desktop and notebook premium logo requirements, including Windows 8.x. The CX23754 includes two stereo Digital-to-Analog Converters (DACs) and Analog-to-Digital Converters (ADCs), a 2.8W AudioSmart™ stereo class-D, a capless headphone, an integrated headset with a detect/switch and GND sense, a universal audio jack, digital microphones, an integrated hardware Equalizer (EQ)/Dynamic Range Compression (DRC), and full-duplex Integrated Interchip Sound (I<sup>2</sup>S) audio streaming interface.

By combining these hardware features with Conexant's extensive voice and speech processing algorithms, the CODEC is the ideal solution for platforms that need Microsoft Lync, Skype, and Automatic Speech Recognition (ASR) certification.

## Applications

- Notebooks
- Ultrabooks
- Desktop and all-in-one PCs
- Tablets
- Embedded applications

## System Compatibility

- *HD Audio Specification 1.0a*
- Windows XP/Vista/7/8.x
- Microsoft Premium Logo
- Linux
- Android

## Features

- Two pairs of independent DACs and ADCs
- Independent sampling rates for DACs and ADCs—supports audio formats ranging from 16-bit to 24-bit, 44.1kHz to 192kHz for DAC, and 44.1kHz to 96kHz for ADC
- AudioSmart class-D intelligent power delivery and dynamic signal loudness optimization maximizes even small speaker Sound Pressure Level (SPL), and ensures no speaker damage
- SpeakerShield technology provides load-based speaker protection independent of driver and application—Protection includes Direct Current (DC), short, near-short, temperature, and power averaging
- Five-band hardware EQ/DRC
- ProCoustic capless stereo headphone driver delivers 52mW into 32Ω load with no pops
- Built-in four-conductor headset jack support with auto-detection and auto-switching between Apple and Nokia style headsets with in-line command sensing
- Hum noise is prevented on external powered speakers plugged into the headset jack when the system is off
- Headphone boost provides up to 1.5V<sub>RMS</sub> output level without performance degradation
- Universal jack supports all headsets, headphones, external microphones, and external line-in devices
- Master Integrated Interchip Sound (I<sup>2</sup>S) transmitter and receiver with selectable signal inversion and programmable drive strengths can be used for direct connection to external amplifiers and docking stations
- Digital Microphone Interface (DMIC) with boost supporting two digital microphone elements and DC offset removal
- Record security prevents unwanted recordings from all or selected input ports
- Analog and digital PC Beep are supported, and Wake-on-beep never misses a beep—even when in low-power mode
- Multiple General Purpose Input/Outputs (GPIOs) for custom applications
- Integrated Low Drop-Out (LDO) regulators
- Headphone limiter supports GS Mark EN50332-2 without an external Bill Of Materials (BOM)

## Revision History

Document No.	Release Date	Change Description
004-23754DSR01	03/12/15	Added 1.8V HD link signaling support.
004-23754DSR00	11/13/14	Initial release.

# Table of Contents

General Description.....	i
Applications .....	i
System Compatibility .....	i
Features.....	i
Revision History .....	ii
Introduction.....	1
Overview.....	1
CX23754 Audio CODEC Features.....	2
System Compatibility .....	4
Hardware Qualification Process (HQP).....	4
Hardware Interface .....	5
General .....	5
High Definition (HD) Audio Host Interface .....	5
Control Signals .....	5
Audio Signals.....	5
CX23754 Block Diagram.....	6
Pin Assignments and Signal Definitions.....	7
Absolute Maximum Ratings.....	14
Electrical Characteristics.....	15
Device Performance Specifications.....	16
Power Management and Power Consumption.....	19
Power Management.....	19
Power Supply Minimum/Maximum Ratings .....	19
Power Consumption .....	20
Integrated Low Drop-Out (LDO) Regulators .....	21
Hardware Equalizer (EQ)/Dynamic Range Compression (DRC).....	21
Digital High-Pass Filter (HPF).....	22
Alternating Current (AC) Timing Characteristics.....	23
Digital Microphone Interface (DMIC) .....	23
HD Audio Clocks.....	24
Data Output and Input .....	25
Package Dimensions and Thermal Specifications .....	26
HD Audio Interface.....	28

Overview .....	28
Verbs .....	29
Node ID 00: Root Node .....	30
Node ID 01: Audio Function Group (AFG) .....	31
Nodes 10, 11: DAC 1, 2 Widgets .....	33
Node 12: PC Beep Generator Widget .....	34
Node 13, 14: ADC 1, 2 Widget .....	35
Node 15: Mixer Widget .....	37
Node 16: Port A/Vendor Widget .....	38
Node 17: Port G .....	39
Node 18: Port B Widget .....	40
Node 19: Port D Widget .....	42
Node 1A: Port C Widget .....	43
Node 1B: Vendor Widget—EQ and DRC Settings .....	44
Node 1D: Port E Widget—I <sup>2</sup> S Output .....	45
Node 1E: Port F Widget – I <sup>2</sup> S Input .....	46
Ordering Information .....	47

## List of Figures

Figure 1: CX23754 Block Diagram .....	6
Figure 2: CX23754 56-QFN Hardware Interface Signals.....	7
Figure 3: CX23754 56-QFN Pad Signals.....	8
Figure 4: Power Supply Rejection for Class-D Amplifier Output.....	17
Figure 5: Power Supply Rejection for Headphone Amplifier Output.....	17
Figure 6: Class-D Output Power vs Load (1% THD) .....	18
Figure 7: HPF Response .....	22
Figure 8: Digital Microphone Clock Timing Waveform.....	23
Figure 9: BIT_CLK and SYNC Timing Waveforms .....	24
Figure 10: Data Output and Input Timing Waveforms .....	25
Figure 11: CX23754 56-QFN Package Drawing.....	26

## List of Tables

Table 1: CX23754 Pad Signals.....	9
Table 2: Pad Signal Definitions.....	10
Table 3: Absolute Maximum Ratings .....	14
Table 4: DC Characteristics—Digital Microphone.....	15
Table 5: DC Characteristics—TTL Compatible (GPIOs, SPKR_MUTE#, and MUSIC_REQ) .....	15
Table 6: Analog Performance Characteristics .....	16
Table 7: Device Power State Mapping.....	19
Table 8: DC Supply Voltages.....	19
Table 9: AFG D3 Power Consumption.....	20
Table 10: Full Scale Headphone Playback (32Ω Load) .....	20
Table 11: Full Scale Class-D Playback (1W per Channel) .....	20
Table 12: Line-In Recording.....	21
Table 13: Digital Microphone Timing Parameters.....	23
Table 14: BIT_CLK and SYNC Timing Parameters.....	24
Table 15: HD Audio Output Valid Delay Timing Parameters .....	25
Table 16: HD Audio Input Setup and Hold Timing Parameters .....	25
Table 17: Thermal Specifications.....	27
Table 18: Node 0 Responses .....	30
Table 19: Node 01 Responses .....	31
Table 20: Node 10 and 11 Responses .....	33
Table 21: PC Beep Generator Responses .....	34
Table 22: Node 13 and 14 Responses .....	35
Table 23: Node 15 Responses .....	37
Table 24: Node 16 Responses .....	38
Table 25: Node 17 Responses .....	39
Table 26: Node 18 Response .....	40
Table 27: Node 19 Response .....	42
Table 28: Node 1A Responses.....	43
Table 29: Node 1B Responses.....	44
Table 30: Node 1D Responses.....	45
Table 31: Node 1E Response.....	46
Table 32: CX23754 Ordering Information and Functions .....	47

# Introduction

## Overview

Conexant's CX23754 is a low-power, 102dB SNR, HD audio CODEC that delivers high-quality audio for the mobile PC market, including notebooks, ultrabooks, and tablets.

Compliant with Intel's *HD Audio Specification 1.0a*, the CX23754 has audio fidelity that exceeds Microsoft desktop and notebook premium logo requirements, including Windows 8.x. With two 24-bit stereo DACs that operate at sampling frequencies up to 192kHz and two 24-bit stereo ADCs that operate at sampling frequencies up to 96kHz, the CODEC can support multi-streaming and RTC applications. By combining these hardware features with Conexant's extensive voice and speech processing algorithms, the CODEC is the ideal solution for platforms that need Microsoft Lync, Skype, and ASR certification.

The CX23754 has an integrated stereo AudioSmart™ class-D intelligent power delivery and dynamic signal loudness optimization that is capable of driving up to  $2.8W_{RMS}$  per channel into 4W loads.

SpeakerShield technology provides industry-leading, load-based protection in real-time that includes DC detection, short-circuit, near-short, high temperature, over-temperature, and power averaging.

The tri-state, ProCoustic capless headphone driver produces a full-range frequency response and eliminates external Field Effect Transistors (FETs) for supporting headsets. Integrated auto-detect and auto-switch between Apple and Nokia style headsets eliminates all external BOM costs. In-line command sensing enables control of third-party applications directly from the headset. Dedicated ground sense pins for headphones/headsets ensure maximum performance and minimum crosstalk.

A single universal jack supports headsets, headphones, external microphones, and line-in devices. A Pulse Density Modulated (PDM) single-bit stream interface supports two digital microphones with DC offset removal for array implementations. D3 Live allows external audio devices to play through internal speakers with full speaker EQ/DRC while the system is asleep.

The full-duplex I<sup>2</sup>S audio interface with integrated inverter and programmable drive strength is ideal for digital docking Input/Output (I/O) expansion, interfacing with external digital amplifiers or devices.

Conexant's PopShield technology eliminates pops and clicks during all transition states, and includes active DC offset removal. The CX23754 has D-Flex power management that exceeds Intel's ECR 15B requirements and consumes minimum power during connected standby by powering down DACs, ADCs, and amplifiers without pops or clicks.

Conexant offers comprehensive audio software driver support, with both in-house and third-party software APOs, including Andrea Electronics, Creative Labs, Dolby, DTS, Sonic Focus, MaxxAudio, Waves, and more. Conexant's AudioSmart voice and speech processing algorithm suite ensures clear voice communication and speech command and control in noisy environments. The Smart Source Pickup (SSP) does not use or rely on beam-forming techniques, and provides an easy to use powerful solution that requires few or no user controls. The SSP passes the latest Intel ASR certification in all orientations with just two microphones, and is available for Windows, Linux, and Android. AudioSmart also offers keystroke, screen tapping, and fan noise suppression. Conexant's AudioSmart software solutions solve common, real-world problems that work much better than traditional beam forming noise reduction approaches with no complexity.

## CX23754 Audio CODEC Features

The following lists the CX23754 audio CODEC features:

- Two pairs of independent DACs and ADCs
- Independent sampling rates for DACs and ADCs—Supports audio formats ranging from 16-bit to 24-bit, 44.1kHz to 192kHz for DAC, and 44.1kHz to 96kHz for ADC
- 2.8W<sub>RMS</sub> per channel stereo class-D with spread spectrum and common mode scrambling to reduce Electro-Magnetic Interference (EMI)
- AudioSmart class-D intelligent power delivery and dynamic signal loudness optimization maximizes even small speaker Sound Pressure Level (SPL) and ensures no speaker damage
- Five-band hardware EQ/DRC
- SpeakerShield technology provides load-based speaker protection independent of driver and application—Protection includes DC, short, near-short, temperature, and power averaging
- ProCoustic capless stereo headphone driver delivers 52mW into 32Ω load with no pops
- Built-in four-conductor headset jack support with auto-detection and auto-switching between Apple and Nokia style headsets with in-line command sensing
- Headphone boost provides up to 1.5V<sub>RMS</sub> output level without performance degradation
- Dedicated ground sense pins for headphones/headsets ensure maximum performance and minimum crosstalk
- Hum noise is prevented on external powered speakers plugged into the headset jack when the system is off
- Headphone boost provides up to 1.5V<sub>RMS</sub> output level without performance degradation
- Universal jack supports all headsets, headphones, external microphones, and external line-in devices
- Master I<sup>2</sup>S transmitter and receiver with selectable signal inversion and programmable drive strengths can be used for direct connection to external devices and docking stations
- DMIC with boost supports two digital microphone elements and DC offset removal
- Record security prevents unwanted recordings from all or selected input ports
- Analog and digital PC Beep are supported, and Wake-on-beep never misses a beep—even when in low-power mode
- Multiple GPIOs for custom applications
- Speaker mute control input selectively mutes the class-D outputs
- Integrated LDO regulators
- Headphone limiter supports GS Mark EN50332-2 without an external BOM
- Integrated:
  - 5V to 3.3V LDO voltage regulator for improved analog audio performance
  - 3.3V to 1.8V LDO voltage regulator used to power digital blocks
- Independent ground connections for each class-D, digital, and analog sections ensure maximum performance
- 1.5V, 1.8V and 3.3V HD audio link signaling levels are selectable
- Pop Shield II for enhanced pop and click suppression
- Jack sense detects jack events as well as enabling hardware-only selections for class-D mono mode and port C mono mode without Basic Input/Output System (BIOS) intervention
- I<sup>2</sup>S dock jack senses for output and input dock jacks eliminate external BOM
- An integrated digital mixer is used to record what is playing

- D3 Live allows external audio devices to play to the internal speakers with EQ/DRC while the system is asleep
- D-Flex enhanced power management exceeds Intel ECR 15B requirements
- Compliant with Intel's *HD Audio Specification 1.0a*, and fidelity exceeds Vista/Windows 7/Windows 8.x desktop and notebook Premium Logo requirements
- AudioSmart speech/voice pre-processing algorithms are available:
  - End-to-end noise reduction
  - True stereo Acoustic Echo Cancellation (AEC)
  - SSP:
    - Solves common, real-world problems, and works much better than traditional beam-forming noise reduction approaches—works in all orientations (portrait, landscape, and LCD panel flat on a table) with a stereo microphone only and without user control changes
    - Optimizes hit rates for speech recognition applications like Nuance—solution ensures near flawless hit rates while other processing like keystroke suppression and VOIP enhancements remain enabled simultaneously
  - Best-in-class keystroke suppression, tap suppression, and fan noise suppression solutions
  - Far Field Pickup enables far field speakerphone and group conference call applications
- 10-band digital parametric SmartEQ enhances the sound quality on low-cost speakers
- Night mode boosts vocal clarity while maintaining background sound quality
- Multi-band DRC further improves the sound quality and loudness of low-cost speakers and prevents speaker rattle and distortion
- Phantom bass creates virtual bass content on mainstream speakers
- 3D:
  - Expander widens the audio stage for fuller and richer sound
  - Headphone recreates a surround, speaker-like environment in headphones so users can enjoy a richer, fuller music listening experience
- AudioSmart GUI—Advanced audio control panel
- Audio director for classic and multi-stream selections
- Third-party software support includes:
  - DTS, Inc.
  - Dolby
  - Creative Labs
  - ForteMedia
  - Andrea
  - Waves (MaxxAudio)
- Supports 32-bit/64-bit Windows OS and Linux
- Available in a 56-pad, thermally-enhanced Quad Flat No-leads (QFN) package

## System Compatibility

- *HD Audio Specification 1.0a*
- Windows XP/Vista/7/8.x
- Microsoft Premium Logo
- Linux
- Android

## Hardware Qualification Process (HQP)

The Hardware Qualification Process (HQP) is intended to improve the quality and reliability of board designs using the CX23754. The goals of this process are to:

- Eliminate common design mistakes
- Ensure boards perform well and pass Driver Test Manager (DTM) fidelity requirements with good margin
- Eliminate potential manufacturing issues that may result from a marginal design
- Eliminate country-specific issues
- Eliminate INF problems
- Converge towards standard designs

The HQP process includes review of schematics, board layout, and BOM. All boards must meet the pre-defined criteria. Contact the local Conexant sales office for more details about the HQP process. The HQP process must be performed for all Original Equipment Manufacturer (OEM) designs.

# Hardware Interface

## General

### High Definition (HD) Audio Host Interface

The HD audio host interface conforms to Intel's *HD Audio Specification 1.0a*. The following lists the supported HD audio signals:

- Bit clock (BIT\_CLK), input
- Frame sync (SYNC), input
- Serial data output (SDATA\_OUT), input
- Serial data input (SDATA\_IN), input/output
- Master hardware reset (RESET#), input

### Control Signals

The following lists the control signals that are supported from straps or the host:

- Class-D speaker mute (SPKR\_MUTE#), input
- Jack sense (JSENSE), input
- Dock jack senses, input
- GPIOs (GPIO0, GPIO1)
- D3 Live enable, input (MUSIC\_REQ)

### Audio Signals

The following lists the supported audio interface signals:

- Port A (PORTA\_L and PORTA\_R), ProCoustic headphone output/line output, headset
- Port B (PORTB\_L and PORTB\_R), microphone input/line input with Microphone Bias (micbias) voltage
- Port C (PORTC\_L and PORTC\_R), analog or digital microphone input with micbias voltage
- Port D (PortD\_A, PortD\_B), analog headset mono microphone input (supports Apple/Nokia style headset auto-detection and auto-switching with no BOM)
- Port E, I<sup>2</sup>S output
- Port F, I<sup>2</sup>S input
- Port G (LEFT+ and RIGHT+), class-D speaker amplifier stereo/mono output
- PC Speaker Beep pass-through (PC\_BEEP), input

# CX23754 Block Diagram

The following figure shows a simplified block diagram of the CX23754.

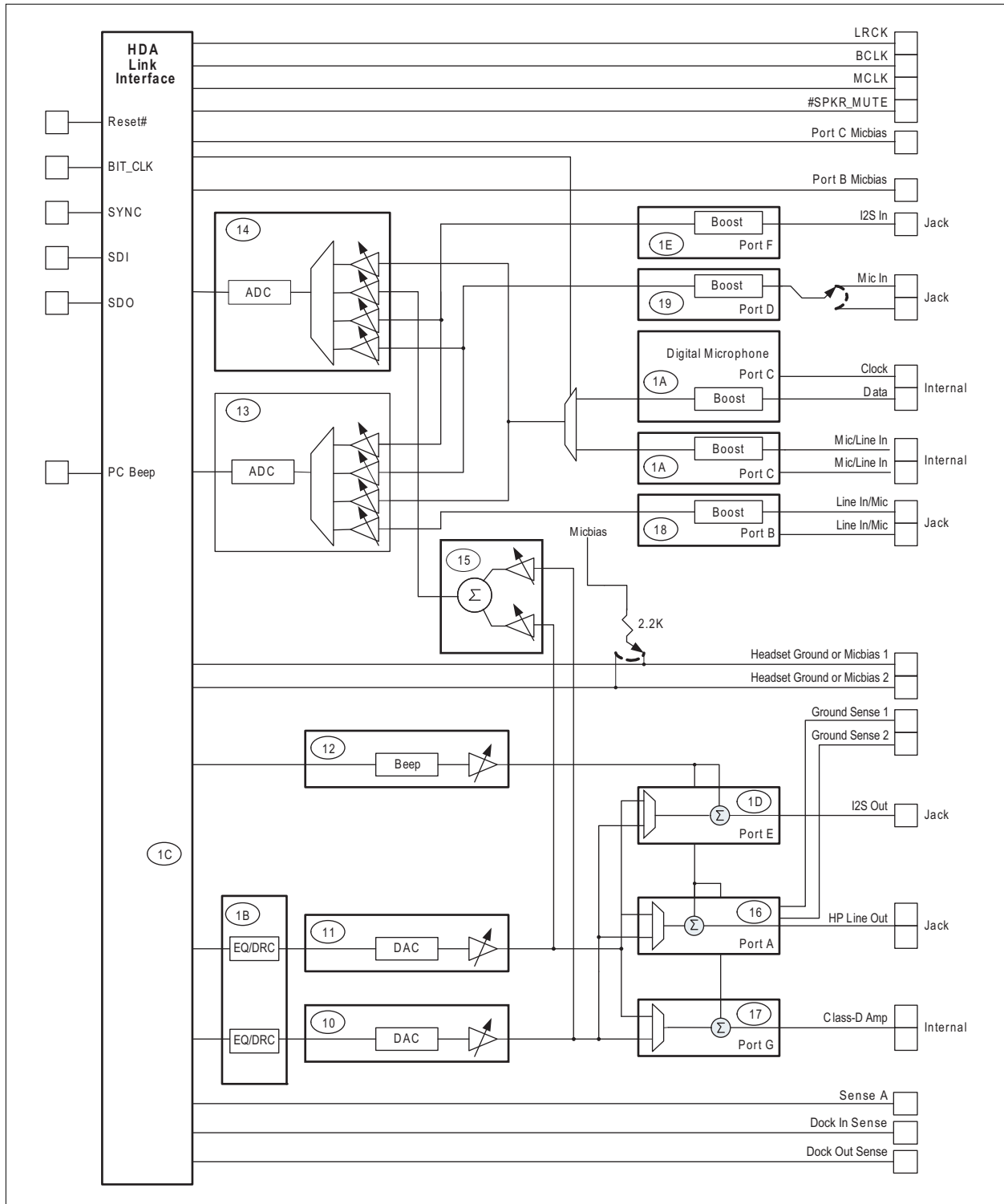

Figure 1: CX23754 Block Diagram

## Pin Assignments and Signal Definitions

The following figure shows the CX23754 56-QFN device signals by major interface.

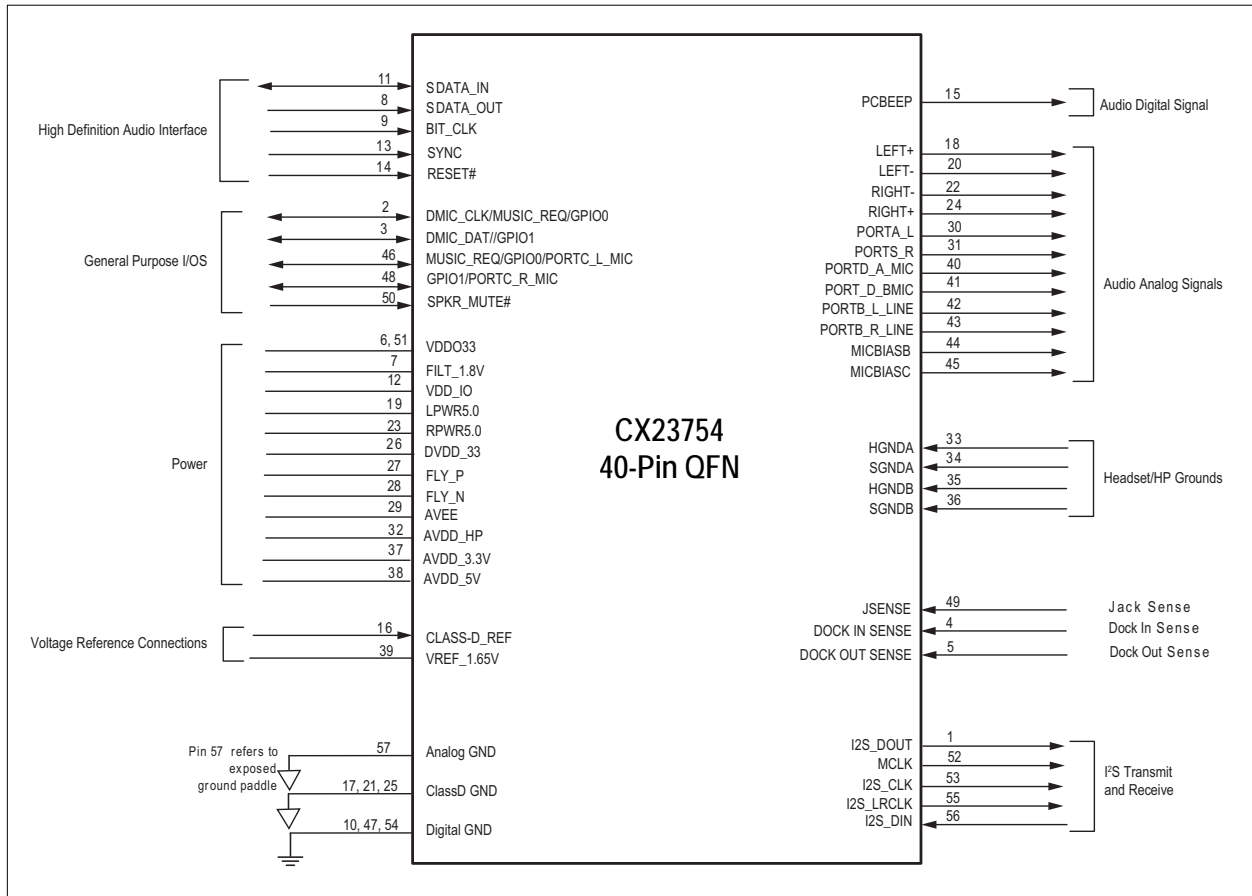

Figure 2: CX23754 56-QFN Hardware Interface Signals

The following figure and Table 1 show the CX23754 56-QFN device signals by pin number.

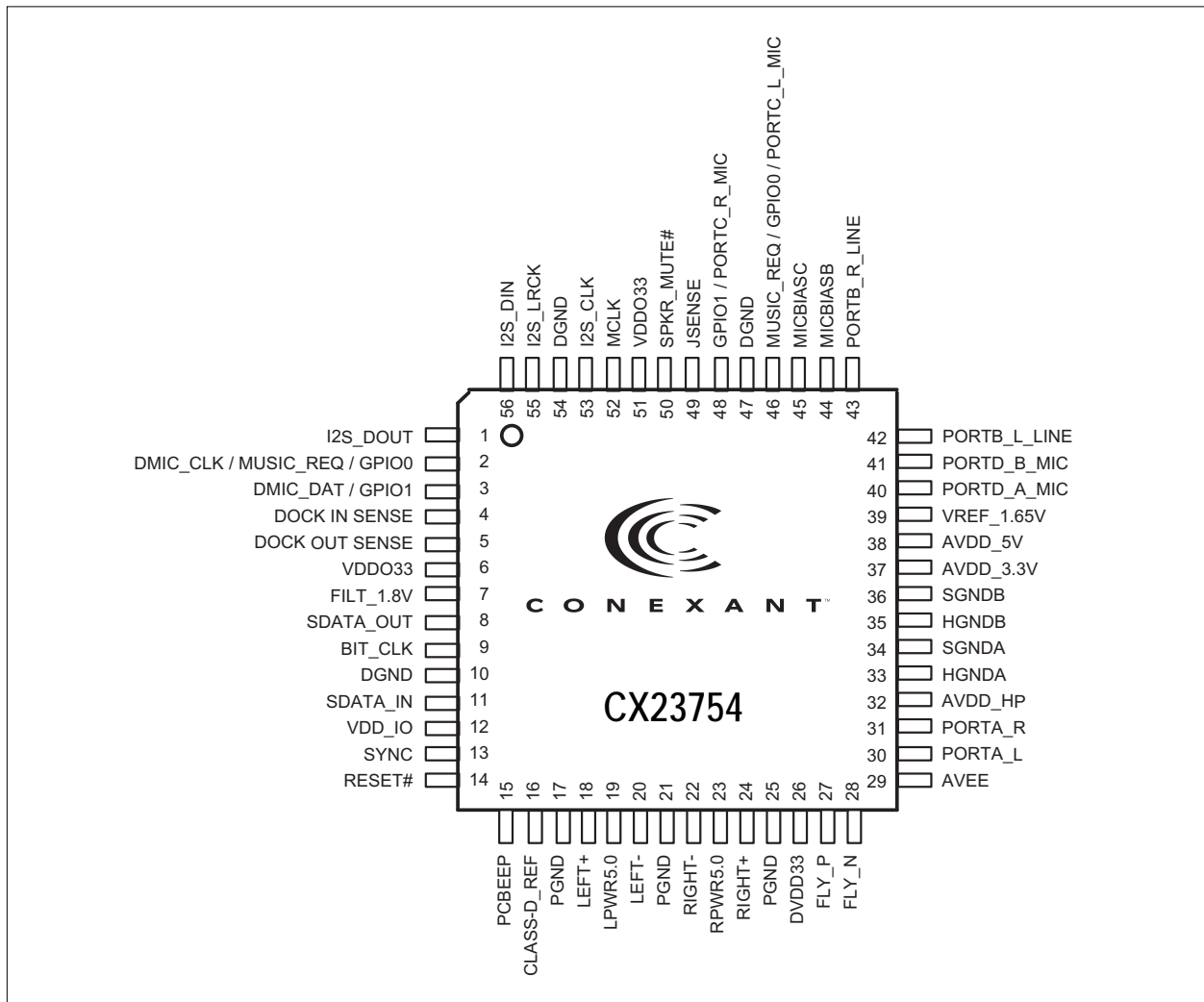

Figure 3: CX23754 56-QFN Pad Signals

**Table 1: CX23754 Pad Signals**

Pad Number	Signal Name	Pad Number	Signal Name
1	I2S_DOUT	29	AVEE
2	DMIC_CLK/MUSIC_REQ/GPIO0	30	PORTA_L
3	DMIC_DAT/GPIO1	31	PORTA_R
4	DOCK IN SENSE	32	AVDD_HP
5	DOCK OUT SENSE	33	HGNDA
6	VDDO33	34	SGNDA
7	FILT_1.8V	35	HGNDB
8	SDATA_OUT	36	SGNDB
9	BIT_CLK	37	AVDD_3.3V
10	DGND	38	AVDD_5V
11	SDATA_IN	39	VREF_1.65V
12	VDD_IO	40	PORTD_A_MIC
13	SYNC	41	PORTD_B_MIC
14	RESET#	42	PORTB_L_LINE
15	PCBEEP	43	PORTB_R_LINE
16	CLASS-D_REF	44	MICBIASB
17	PGND	45	MICBIASC
18	LEFT+	46	MUSIC_REQ/GPIO0/PORTC_L_MIC
19	LPWR5.0	47	DGND
20	LEFT-	48	GPIO1/PORTC_R_MIC
21	PGND	49	JSENSE
22	RIGHT-	50	SPKR_MUTE#
23	RPWR5.0	51	VDDO33
24	RIGHT+	52	MCLK
25	PGND	53	I2S_CLK
26	DVDD_3.3	54	DGND
27	FLY_P	55	I2S_LRCK
28	FLY_N	56	2S_DIN

**Note:** Pin 57 refers to the 57 exposed ground paddles for the analog GND.

The following lists the acronyms used in Table 2:

- GND = Ground
- I = Input
- Ia = Input analog
- Id = In Digital
- IHD = Input High Definition
- O = Output
- Oa = Output analog
- Od = Out digital
- PWR = Power
- Ref = Reference

**Table 2: Pad Signal Definitions**

Label	Pad Number	Type	I/O Type	Signal Name/Description
<b>Power</b>				
VDD0_3.3	6.51	PWR	I	<b>Digital Supply Voltage.</b> 3.3V—Connect to the 3.3V system.
FILT_1.8V	7	PWR	O	<b>Internally Regulated Digital Core Supply Voltage.</b> 1.8V –5%/10%—Connect to an external decoupling capacitor.
VDD_IO	12	PWR	I	<b>Input/Output Signaling Voltage Supply.</b> Determines the signaling voltage that is being used on the host system. When VDD_IO is: <ul style="list-style-type: none"> <li>• 1.5V, the device uses 1.5V signaling on the HDA interface pins</li> <li>• 1.8V, the device uses 1.8V signaling on the HDA interface pins</li> <li>• 3.3V, the device uses 3.3V signaling on the HDA interface pins</li> </ul>
LPWR_5.0	19	PWR	I	<b>Supply Voltage for Class-D Amplifier, Left Channel.</b> 5V—Connect to RPWR_5.0. Connect LPWR_5.0/RPWR_5.0, and then to the 5V system supply.
RPWR_5.0	23	PWR	I	<b>Supply Voltage for Class-D Amplifier, Right Channel.</b> 5V—Connect to LPWR_5.0. Connect LPWR_5.0/RPWR_5.0, and then to the 5V system supply.
DVDD_3.3	26	PWR	I	<b>Charge Pump Input Supply Voltage.</b> 3.3V—Connect to the 3.3V system.
FLY_P	27	PWR	Ref	<b>Charge Pump Negative Transfer Charge.</b> Connected to FLY_N through a 1μF capacitor.
FLY_N	28	PWR	Ref	<b>Charge Pump Negative Transfer Charge.</b> Connected to FLY_P through a 1μF capacitor.
AVEE	29	PWR	O	<b>Internally Generated Analog Negative Supply.</b> –2.0V –10%/15%—Connect to an external decoupling capacitor. <i>Note:</i> If headphone boost is enabled, this is –2.6V.
AVDD_HP	32	PWR	I	<b>Supply Input Voltage for Headphone Amplifiers.</b> 3.3V—Connect to the 3.3V system.
AVDD_3.3	37	PWR	O	<b>Output Voltage from LDO.</b> 3.3V –5%/10%—Connect to an external decoupling capacitor.
AVDD_5V	38	PWR	I	<b>Analog Supply Input Voltage for LDO.</b> 5V—Connect to the 5V system supply.
<b>Ground (GND)</b>				
HGNDA	33	GND	GND	<b>Headset Microphone Ground.</b> Microphone: <ul style="list-style-type: none"> <li>• Ground terminal for Apple-style headsets</li> <li>• Bias for Nokia-style headsets</li> </ul>

Label	Pad Number	Type	I/O Type	Signal Name/Description
SGNDA	34	GND	GND	<b>Headset/Headphones Ground Sense.</b> Ground sense for the headphone and headset jack to ensure maximum performance and minimum crosstalk.
HGNDB	35	GND	GND	<b>Headset Microphone Ground.</b> Microphone: <ul style="list-style-type: none"> <li>• Ground terminal for Nokia-style headsets</li> <li>• Bias for Apple-style headsets.</li> </ul>
SGNDB	36	GND	GND	<b>Headset/Headphones Ground Sense.</b> Ground sense for the headphone and headset jack to ensure maximum performance and minimum crosstalk.
GND	57	GND	GND	<b>CODEC Ground.</b> Thermal/electrical GND paddle of the device. Connect to the system and audio ground.
PGND	17, 21, 25	GND	GND	<b>Class-D Ground.</b> Independent ground return for class-D.
DGND	10, 47, 54	GND	GND	<b>Digital Ground.</b> Independent ground return for digital sections.
<b>HD Audio Interface</b>				
SDATA_OUT	8	I	IHD	<b>Serial Data Output.</b> Serial input data stream from an HDA controller. <ul style="list-style-type: none"> <li>• Reset state = Low</li> <li>• Standard load = 50pF</li> </ul> Connect to SDATA_OUT through 33Ω.
BIT_CLK	9	I	IHD	<b>Bit Clock.</b> 24MHz serial data input bit clock from the HDA link. Connect to BIT_CLK.
SDATA_IN	11	I/O	IHD	<b>Serial Data Input.</b> Serial output data stream to the HDA controller. Functions as an input during CODEC initialization. Controller has a weak pull-down resistor to prevent spurious events in electrically noisy environments. Connect to SDATA_IN through 33Ω.
SYNC	13	I	IHD	<b>Frame Sync.</b> 48kHz fixed rate sample HDA sync input. Synchronization pulse from an HDA compliant controller to all of the HDA compliant CODECs on the link. This signal is nominally a 0.167μs wide pulse that is used to synchronize the HDA. <ul style="list-style-type: none"> <li>• Reset state = Low</li> <li>• Standard load = 50pF</li> </ul> SYNC is derived from dividing BIT_CLK by 500. Connect to SYNC.
RESET#	14	I	IHD	<b>Master Hardware Reset.</b> Active low HDA link reset signal. The minimum width of this pulse must be 100μs. Connect directly to RESET.
<b>Reference Voltage Connections</b>				
CLASSD_REF	16	REF	Ref	<b>Class-D Amplifier Reference Voltage.</b> Connect to the RPWR_5.0/LPWR_5.0 voltage supply through an external capacitor.
VREF_1.65V	39	REF	Ref	<b>Analog Reference Voltage.</b> 1.65V –6%/12%—Connect to an external decoupling capacitor.

Label	Pad Number	Type	I/O Type	Signal Name/Description
<b>GPIOs</b>				
DMIC_CLK/ MUSIC_REQ/GPIO0	2	I/O	Id/Od	<b>Multi-purpose I/O Pin.</b> Use: <ul style="list-style-type: none"> <li>DMIC_CLK for the microphone clock input when Port C is configured for the digital microphone</li> <li>MUSIC_REQ to enable D3 Live mode</li> <li>GPIO0 for GPIO applications</li> </ul>
DMIC_DAT/ GPIO1	3	I/O	Id/Od	<b>Multi-purpose I/O Pin.</b> Use: <ul style="list-style-type: none"> <li>DMIC_DAT for the microphone data input when Port C is configured for the digital microphone</li> <li>GPIO1 for GPIO applications</li> </ul>
MUSIC_REQ/ GPIO0/ PORTC_L_MIC	46	I/O	Id/Od	<b>Multi-purpose I/O Pin.</b> Use: <ul style="list-style-type: none"> <li>MUSIC_REQ to enable the D3 Live mode</li> <li>GPIO0 for GPIO applications</li> <li>PORTC_L_MIC for the microphone left input when Port C is configured for analog microphone input</li> </ul>
GPIO1/ PORTC_R_MIC	48	I/O	Id/Od	<b>Multi-purpose I/O Pin.</b> Use: <ul style="list-style-type: none"> <li>GPIO1 for GPIO applications</li> <li>PORTC_R_MIC for microphone right input when Port C is configured for analog microphone input</li> </ul>
SPKR_MUTE#	50	I	Id	<b>Class-D Speaker Mute.</b> External control input to mute class-D speakers. Active low. Optional.
<b>Audio Digital Signals</b>				
PCBEEP	10	I	Ia	<b>PC Speaker Beep Pass-through.</b> Input. Logic-level BEEP signal needs to be AC-coupled to this pin. The default gain setting is: <ul style="list-style-type: none"> <li>-28dB on the speakers</li> <li>-46dB on the headphone</li> </ul>
<b>Audio Analog Signals</b>				
LEFT+	12	O	Oa	<b>Class-D Amplifier Output, Left Channel, Positive.</b>
LEFT-	14	O	Oa	<b>Class-D Amplifier Output, Left Channel, Negative.</b>
RIGHT-	15	O	Oa	<b>Class-D Amplifier Output, Right Channel, Negative.</b>
RIGHT+	17	O	Oa	<b>Class-D Amplifier Output, Right Channel, Positive.</b>
PORTA_L	22	O	Oa	<b>Headphone Output/Line Output, Left Channel.</b> A ProCoustic (capless) headphone output.
PORTA_R	23	O	Oa	<b>Headphone Output/Line Output, Right Channel.</b> A ProCoustic (capless) headphone output.
PORTD_A_MIC	30	I	Ia	<b>Headset Microphone Input.</b> Mono microphone input for Apple-style headsets.
PORTD_B_MIC	31	I	Ia	<b>Headset Microphone Input.</b> Mono microphone input for Nokia/OMTP-style headsets.
PORTB_L_LINE	32	I	Ia	<b>Microphone Input/Line Input, Left Channel.</b> With micbias voltage.
PORTB_R_LINE	33	I	Ia	<b>Microphone Input/Line Input, Right Channel.</b> With micbias voltage.
MICBIASB	34	REF	Ref	<b>Micbias Voltage for Port B.</b>
MICBIASC	35	REF	Ref	<b>Micbias Voltage for Port C.</b>
JSENSE	38	I/O	I/Oa	<b>Jack Sense Input.</b>

Label	Pad Number	Type	I/O Type	Signal Name/Description
DOCK IN SENSE	4	I	Ia	<b>Jack Sense Input for I<sup>2</sup>S Dock Microphone/Line-in Jack.</b>
DOCK OUT SENSE	5	I	Ia	<b>Jack Sense Input for I<sup>2</sup>S Dock Headphone/Line-out Jack.</b>
<b>I<sup>2</sup>S Signals<sup>1</sup></b>				
I2S_DOUT	1	O	Od	<b>I<sup>2</sup>S Data Output.</b>
MCLK	52	O	Od	<b>I<sup>2</sup>S Master Clock Output.</b> Selectable 24MHz, 12MHz (default), 24.576MHz, and 12.288MHz.
I2S_CLK	53	O	Od	<b>I<sup>2</sup>S Bit Clock Output.</b> Selectable 1.536MHz (16-bit samples) or 3.072MHz (default, 24-bit samples).
I2S_LRCLK	55	O	Od	<b>I<sup>2</sup>S Word Clock Output.</b> 48kHz.
I2S_DIN	56	I	Id	<b>I<sup>2</sup>S Data Input.</b>

1 = Drive strength selectable—signal polarity selectable.

## Absolute Maximum Ratings

The following table lists the device's absolute maximum ratings.

**Table 3: Absolute Maximum Ratings**

Parameter	Symbol	Limits	Units
Supply Voltage	DVDD_3.3/VDDO_3.3	3.6	V
	VDD_IO	3.6/1.65 <sup>1</sup>	
	AVDD_HP	3.6	
	AVDD_5V	5.5	
	RPWR_5.0/LPWR_5.0	5.5	
Digital Input Voltage	$V_{ind}$	-0.7 to 4	V
Analog Input Voltage	$V_{ina}$	-0.7 to 4	V
DC Clamp Current, Input	$I_{ik}$	$\pm 20$	mA
DC Clamp Current, Output	$I_{ok}$	$\pm 20$	mA
Storage Temperature Range	$T_{stg}$	-55 to 125	°C
Operating Temperature Range	$T_{op}$	0 to 70	°C

1 = Depends on the HD audio signaling level.

## Electrical Characteristics

The following table lists the electrical characteristics for the DMIC.

**Table 4: DC Characteristics—Digital Microphone**

Parameter	Symbol	Minimum	Typical	Maximum	Units	Notes
Input Voltage Low	$V_{IL}$	-0.3	-	$0.35 \times V_{DDO\_3.3}$	V	-
Input Voltage High	$V_{IH}$	$0.65 \times V_{DDO\_3.3}$	-	3.3	V	-
Output Voltage Low	$V_{OL}$	-	-	0.4	V	-
Output Voltage High	$V_{OH}$	$V_{DDO\_3.3} - 0.4$	-	-	V	-
Drive Strength	-	0.3	4	6.8	mA	Adjustable

**Note:**

- Test conditions unless otherwise stated:
  - DVDD =  $3.3 \pm 0.165$  VDC
  - TA = 0°C to 70°C
  - External load = 50 pF
- Input load 20μA (weak pull-down)

The following table lists the device's DC characteristics for the TTL-compatible I/Os.

**Table 5: DC Characteristics—TTL Compatible (GPIOs, SPKR\_MUTE#, and MUSIC\_REQ)**

Parameter	Symbol	Minimum	Typical	Maximum	Units	Notes
Input Voltage	$V_{IN}$	-	-	4	V	-
Input Voltage Low	$V_{IL}$	-0.5	-	0.8	V	-
Input Voltage High	$V_{IH}$	2	-	Vdd+0.5	V	-
Output Voltage Low	$V_{OL}$	0	-	0.4	V	-
Output Voltage High	$V_{OH}$	2.4	-	Vdd	V	-
GPIO Output Sink Current at 0.4V Maximum	-	-	-	12	mA	-
GPIO Output Source Current at 2.97V Minimum	-	-	-	12	mA	-
GPIO Rise/fall Time	-	-	-	4	ns	25% to 75%

**Note:** Test conditions unless otherwise stated:

- VDDO\_3.3 =  $3.3 \pm 0.165$  VDC
- TA = 0°C to 70°C
- External load = 50pF

## Device Performance Specifications

The tables and graphs in this section illustrate the device's analog performance.

**Table 6: Analog Performance Characteristics**

Parameter	Minimum	Typical	Maximum	Units
<b>Headphone Output</b>				
Full Scale Output Voltage	-	1.3 <sup>1</sup>	-	V <sub>RMS</sub>
Dynamic Range (Measured with –60dBFS Signal Present)	-	99	-	dBFS
Total Harmonic Distortion Plus Noise (THD+N), Measured at –3dBFS	-	–86	-	dB
Channel Crosstalk	-	–75	-	dBFS
Analog Frequency Response (±3dB at 20Hz, ±1dB at 20000Hz)	20	-	20000	Hz
<b>Class-D Speaker Amplifier Outputs</b>				
Full Scale Output Voltage (into 4Ω)	-	4	-	V <sub>p</sub>
	-	2.90	-	V <sub>RMS</sub>
Dynamic Range (Measured with –60dBFS Signal Present)	-	94	-	dBFS
THD+N, Measured at –3dBFS	-	–65	-	dBFS
Analog Frequency Response (±3dB at 20Hz, ±1dB at 20000Hz)	20	-	20000	Hz
Efficiency (Measured at 1W/Ch)	-	85	-	%
<b>Line Inputs</b>				
Full Scale Input Voltage	1	-	-	V <sub>RMS</sub>
Dynamic Range (Measured with –60dBFS Signal Present)	-	92	-	dBFS
THD+N, Measured at –3dBFS	-	–87	-	dB
Channel Crosstalk	-	–84	-	dBFS
Analog Frequency Response (±3dB at 200Hz, ±1dB at 20000Hz)	20	-	20000	Hz
Input Resistance—0dB	-	15.8	-	kΩ
Input Capacitance	-	5	-	pF
<b>Microphone Inputs</b>				
Full Scale Input Voltage with:				
20dB boost	0.1	-	-	V <sub>RMS</sub>
Boost off	1	-	-	-
Dynamic Range (Measured with –60dBFS Signal Present)	-	91	-	dBFS
THD+N, Measured at –3dBFS	-	–87	-	dB
Channel Crosstalk (Measured at 1kHz, 0dB Gain)	-	–84	-	dBFS
Analog Frequency Response (±3dB at 200Hz, ±1dB at 20000Hz)	100	-	20000	Hz
Input Resistance				
0dB		15.8	-	kΩ
10dB–40dB		5	-	-
Input Capacitance	-	5	-	pF

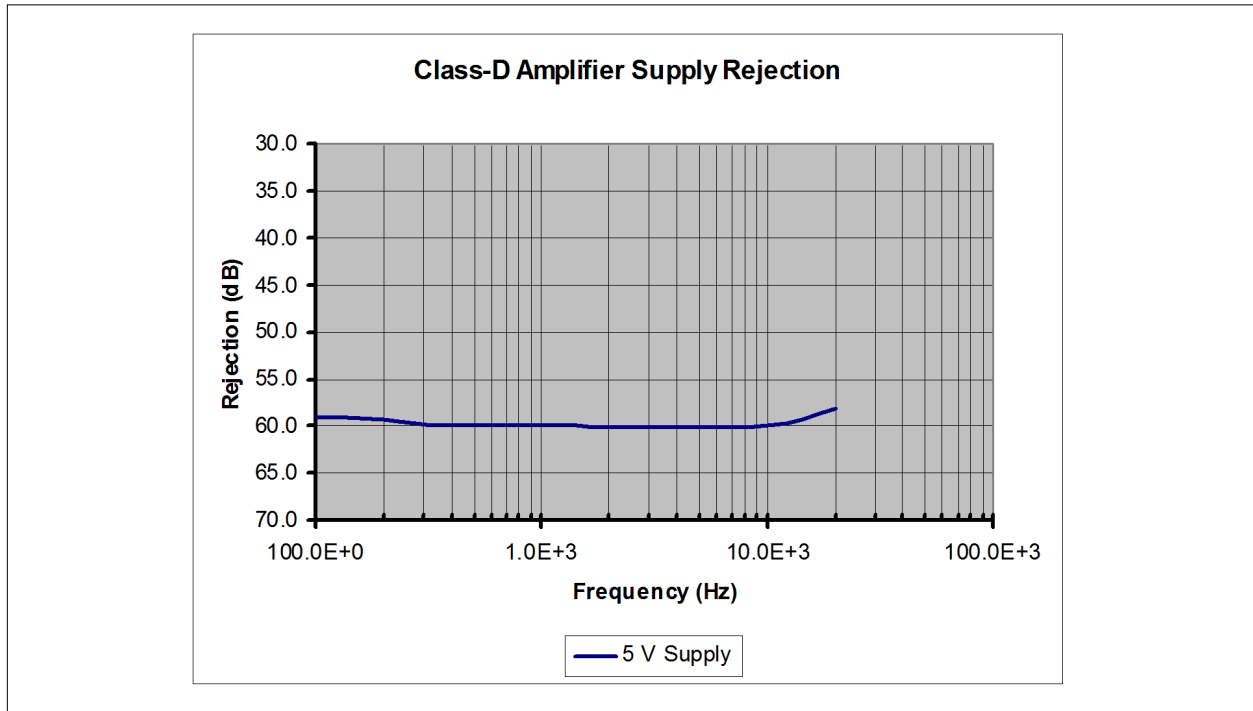

**Figure 4: Power Supply Rejection for Class-D Amplifier Output**

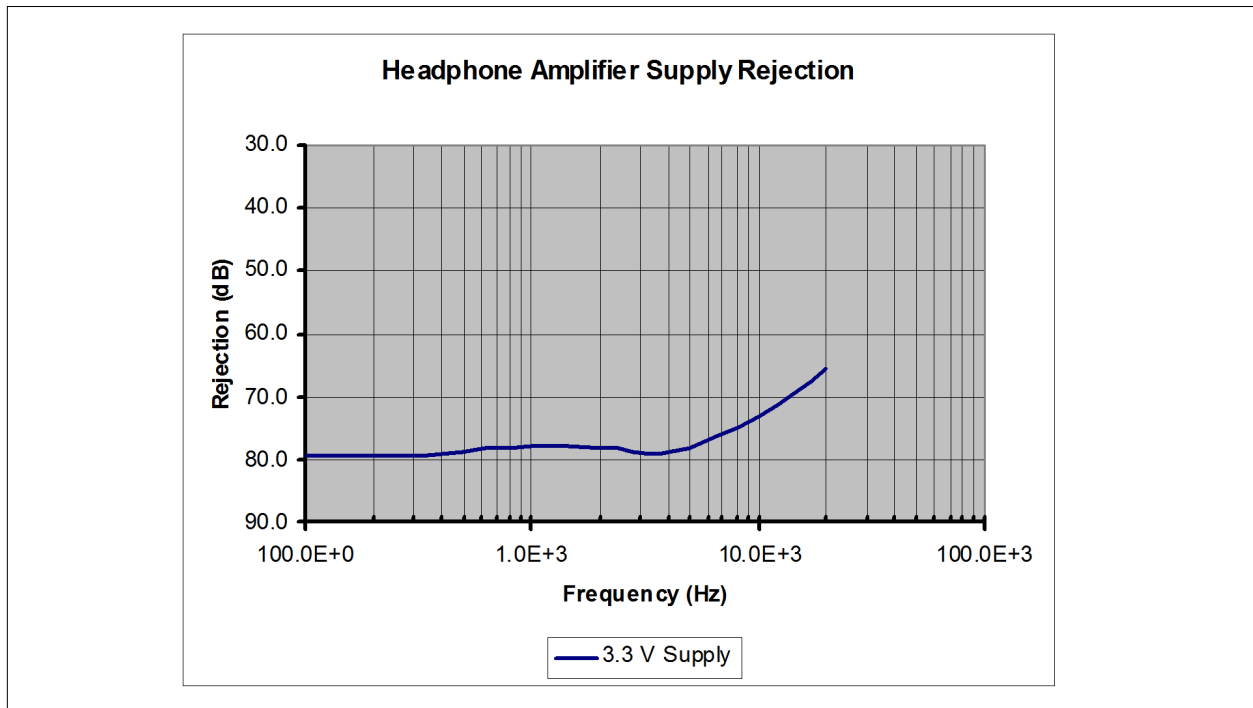

**Figure 5: Power Supply Rejection for Headphone Amplifier Output**

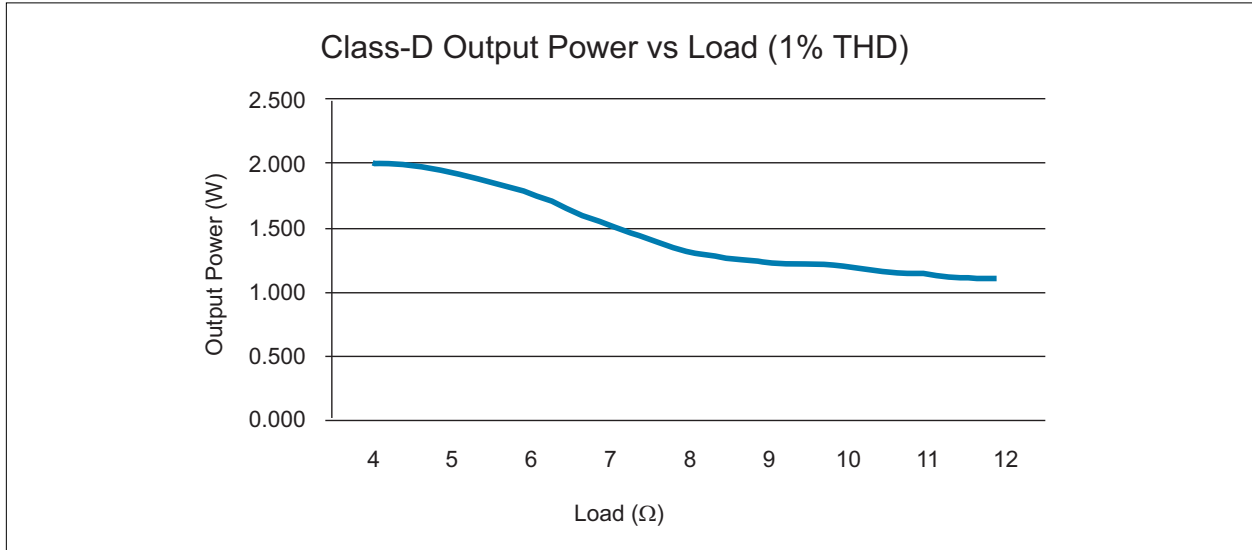

**Figure 6: Class-D Output Power vs Load (1% THD)**

## Power Management and Power Consumption

### Power Management

Advanced power management features allow the device to conserve additional power by disabling/enabling individual functional blocks.

**Table 7: Device Power State Mapping**

Device State	System State	Wake-up Time	Description
D0	S0	-	Device is in full power.
D1, D2	S0-Idle	1ms	Lower power standby (LP1). Transition time to full power is 1ms.
D3	S0-Idle	10ms 75ms	Lowest power standby (LP2). Transition time to full power is 10ms, and an additional 75ms for full fidelity.
D4	S3	200ms	Standby, prepare for shutdown. Transition time to full power 200ms.
D4	S4	200ms	Hibernate, prepare for shutdown. Transition time to full power 200ms.

### Power Supply Minimum/Maximum Ratings

The following table shows the required voltages at the various supply input pins of the devices.

**Table 8: DC Supply Voltages**

Parameter	Symbol	Minimum	Typical	Maximum	Units	Notes
Digital Voltage Supply	VDDO_3.3	3.165	3.3	3.465	V	-
Charge Pump Supply	DVDD_3.3	3.165	3.3	3.465	V	-
HDA Bus Signaling Supply, 3.3V	VDD_IO	3.165	3.3	3.465	V	-
HDA Bus Signaling Supply, 1.8V	VDD_IO	1.71	1.8	1.89	V	-
HDA Bus Signaling Supply, 1.5V	VDD_IO	1.425	1.5	1.575	V	-
Class-D Amp Supply, Left Channel	LPWR_5.0	4.75	5	5.25	V	-
Class-D Amp Supply, Right Channel	RPWR_5.0	4.75	5	5.25	V	-
Headphone Voltage Supply	AVDD_HP	3.165	3.3	3.465	V	-
5V-to-3.3V Regulator Input	AVDD_5V	4.75	5	5.25	V	-

## Power Consumption

Test conditions for the nominal device are at 25°C. The tables in this section provide the power consumption parameters.

**Table 9: AFG D3 Power Consumption**

Power Rail (V)		Bit_CLK		No BIT_CLK	
		mA	mW	mA	mW
AVDD_5V	5	0.3	1.5	0.5	2.4
AVDD_HP	3.3	0	0	0	0.1
SPKPWR	5	0.6	3.1	0.5	2.5
VDDO_3.3	3.3	4.1	13.5	0.9	3
VDD_IO	3.3	0.3	1	0	0
DVDD_3.3	3.3	0	0	0.1	0.2
Total Power Consumption (mW)		19.1		8.1	

**Table 10: Full Scale Headphone Playback (32Ω Load)**

Power Rail (V)		Play 0dB Sine Wave to Capless HP	
		mA	mW
AVDD_5V	5	7.2	35.8
AVDD_HP	3.3	30.7	101.4
SPKPWR	5	0.5	2.5
VDD_IO	3.3	20.5	67.7
VDDIO_3.3	3.3	0.2	0.5
DVDD_3.3	3.3	40.4	133.4
Total Power Consumption (mW)		341.4	

**Table 11: Full Scale Class-D Playback (1W per Channel)**

Power Rail (V)		Play 0dB Sine Wave to Class-D (1W)	
		mA	mW
AVDD_5V	5	14.3	71.7
AVDD_HP	3.3	0	0
SPKPWR	5	473.3	2366.5
VDDO_3.3	3.3	20.5	67.7
VDD_IO	3.3	0.2	0.5
DVDD_3.3	3.3	0.9	2.9
Total Power Consumption (mW)		2509.4	

**Table 12: Line-In Recording**

Power Rail (V)		Line-In Record from Port B	
		mA	mW
AVDD_5V	5	8.8	43.9
AVDD_HP	3.3	0	0
SPKPWR	5	0.5	2.5
VDDO_3.3	3.3	18.9	62.4
VDD_IO	3.3	0.4	1.2
DVDD_3.3	3.3	0.1	0.2
Total Power Consumption (mW)			110.2

### Integrated Low Drop-Out (LDO) Regulators

The devices feature the following two integrated LDO voltage regulators:

- 5V to 3.3V regulator = Although the output of this voltage regulator (AVDD\_3.3) can be used to power external circuitry (e.g., low-power analog), external current consumption from the regulator should be limited to no more than 30mA. Additionally, caution should be used when powering external circuitry, and use filtering (e.g., ferrite bead plus capacitor) to prevent the external circuitry from adding noise to the AVDD\_3.3 voltage rail.
- 3.3V to 1.8V regulator = The output of this voltage regulator (FILT\_1.8) can also be used to power external circuitry (e.g., discrete logic).
- Independent ground connections for each of class-D, digital, and analog sections ensures maximum performance.

### Hardware Equalizer (EQ)/Dynamic Range Compression (DRC)

Five-band EQ/DRC is normally used in the class-D path to protect and equalize the performance of the typically small speakers found in notebooks. The five-channel EQ is implemented with five bi-quad filters that are programmable. The hardware DRC helps to get maximum loudness from speakers while preventing distortion. Easy-to-use tuning tools are available on request.

### Digital High-Pass Filter (HPF)

The device features a hardware digital High-Pass Filter (HPF) that is intended to be applied to the DAC that is mapped to the class-D speaker port (assumed to drive external amplifier or powered speakers). The HPF is enabled and set to 120Hz by default. The cut-off frequency can be adjusted from 30Hz to 1890Hz in 30Hz increments. The purpose of this high-pass is to prevent audio content with a significant DC offset from heating and possibly damaging speakers. Audio content with a large DC component can easily be found in homemade movies and Internet sites. If the class-D is not in use, then the HPF can be assigned to work with the I<sup>2</sup>S output.

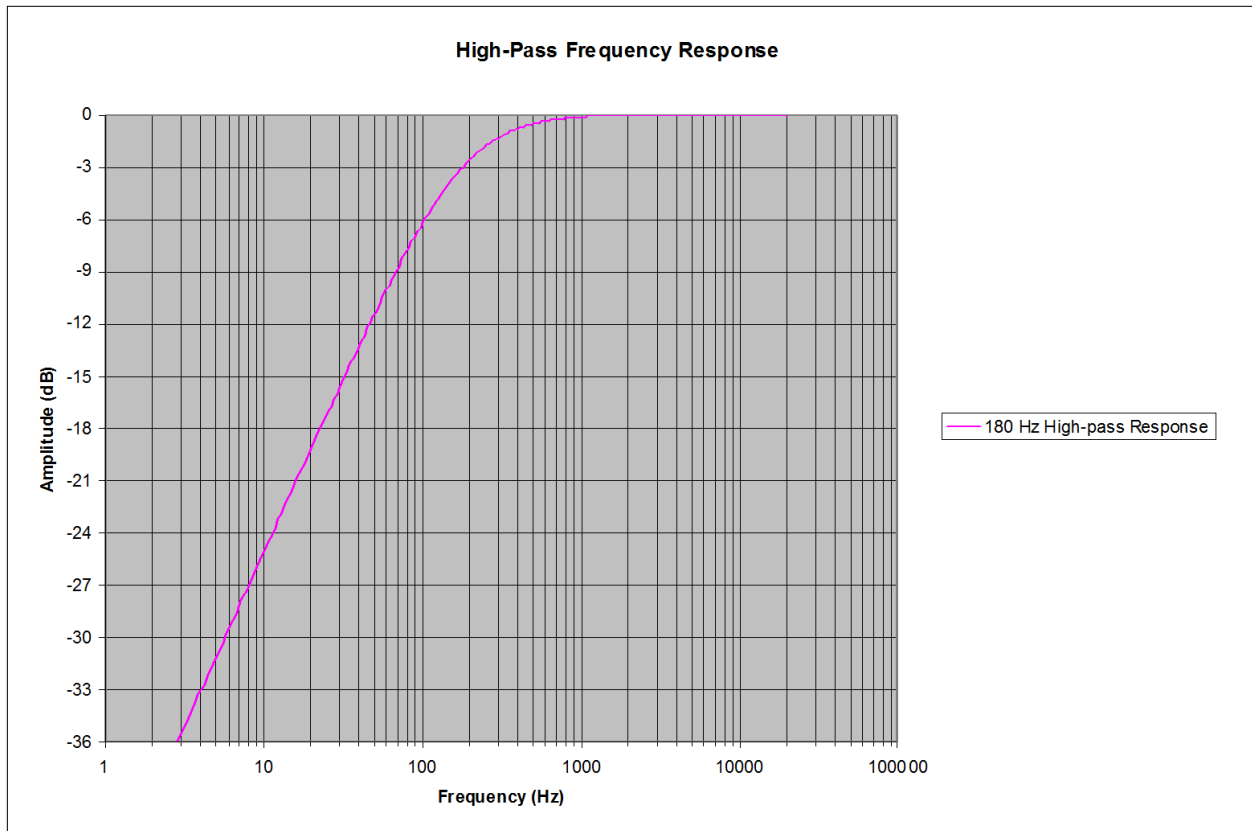

Figure 7: HPF Response

## Alternating Current (AC) Timing Characteristics

### Digital Microphone Interface (DMIC)

The CX23754 DMIC consists of a clock and a data pin. The digital microphone clock pin provides a 3.072MHz (default) or 1.536MHz clock to the digital microphone. The digital microphone data pin is an input, accepting multiplexed PDM data from the digital microphone. [Figure 8](#) illustrates the timing waveforms, and [Table 13](#) lists the timing parameters.

**Note:** For a list of qualified digital microphones, contact a Conexant Sales FAE.

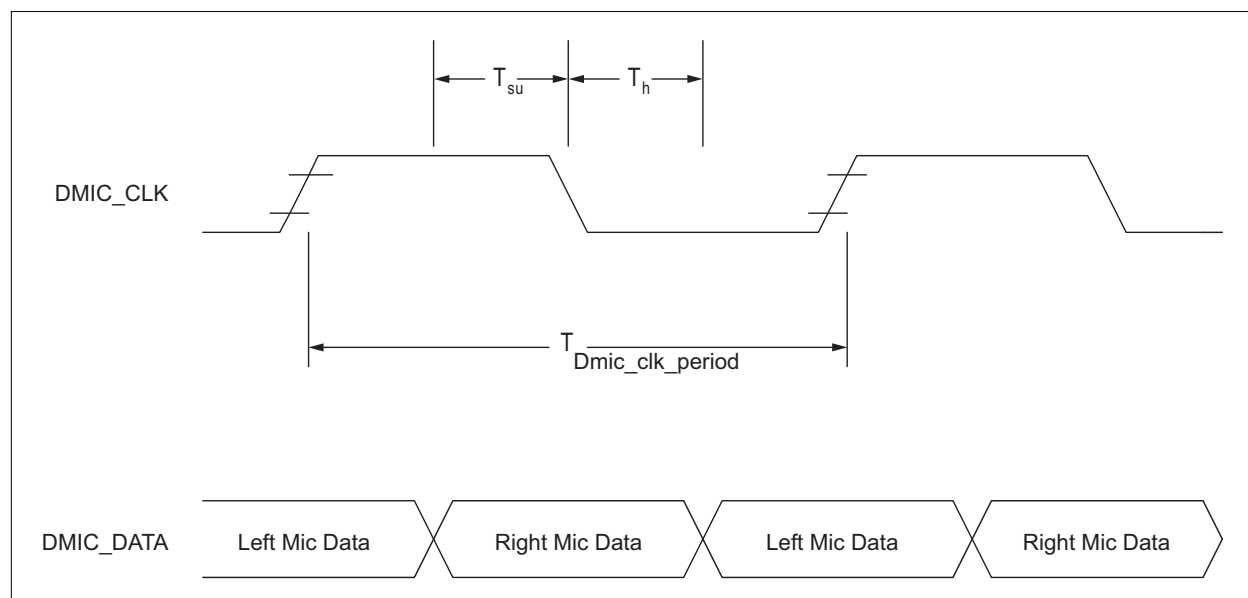

**Figure 8: Digital Microphone Clock Timing Waveform**

**Table 13: Digital Microphone Timing Parameters**

Parameter	Symbol	Minimum	Typical	Maximum	Units
DMIC_CLK Frequency <sup>1</sup>	-	3.0689	3.072	3.0751	MHz
DMIC_CLK Period	T <sub>Dmic_clk_period</sub>	325.19	325.52	325.85	ns
DMIC_CLK Transition Period @ 50pF <sup>2</sup>	-	-	-	4	ns
DMIC_CLK Transition Period @ 20pF <sup>2</sup>	-	-	-	1.9	ns
DMIC_CLK Transition Period @ 7pF <sup>2</sup>	-	-	-	1	ns
DMIC_DATA Setup Time	T <sub>su</sub>	-	36	-	ns
DMIC_DATA Hold Time	T <sub>h</sub>	0	-	-	ns

1 = Worst case duty cycle restricted to 40/60.

2 = Measured between 25% and 75% full scale.

## HD Audio Clocks

The BIT\_CLK signal is a 24MHz clock that is sourced from the HD audio controller and connected to all CODECs on the link. Figure 9 and Table 14 show the HD audio clock waveforms and timing parameters.

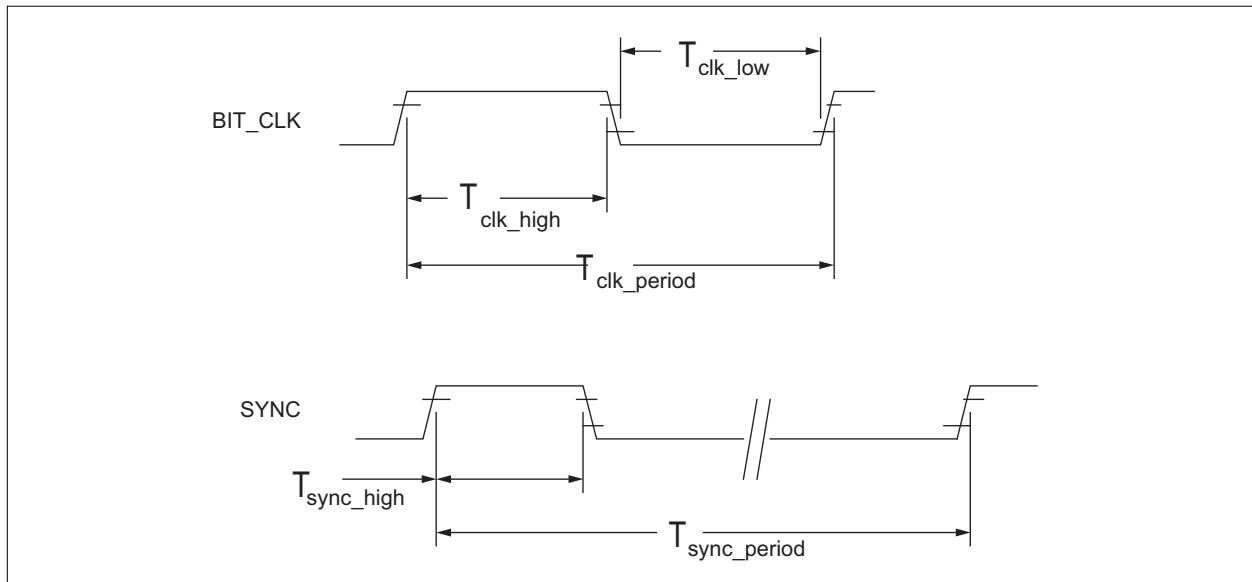

**Figure 9: BIT\_CLK and SYNC Timing Waveforms**

**Table 14: BIT\_CLK and SYNC Timing Parameters**

Parameter	Symbol	Minimum	Typical	Maximum	Units
BIT_CLK Frequency	-	23.9976	24	24.0024	MHz
BIT_CLK Period	Tclk_period	41.363	41.67	41.971	ns
BIT_CLK Output Jitter	-	-	150	500	Ps
BIT_CLK High Pulse Width <sup>1,2</sup>	Tclk_high	18.75	-	22.91	ns
BIT_CLK Low Pulse Width <sup>1,2</sup>	Tclk_low	18.75	-	22.91	ns
SYNC Frequency <sup>3</sup>	-	-	48	-	kHz
SYNC Period	Tsync_period	-	20.8	-	μs
SYNC High Pulse Width	Tsync_high	-	4 x Tclk_period	-	μs

1 = 47.5pF–70pF external load.

2 = Worst-case duty cycle restricted to 40/60.

3 = The SYNC frequency is equal to the BIT\_CLK frequency, divided by 500.

## Data Output and Input

Figure 10 illustrates the data output and input waveforms, and Table 15 and Table 16 list the timing parameters.

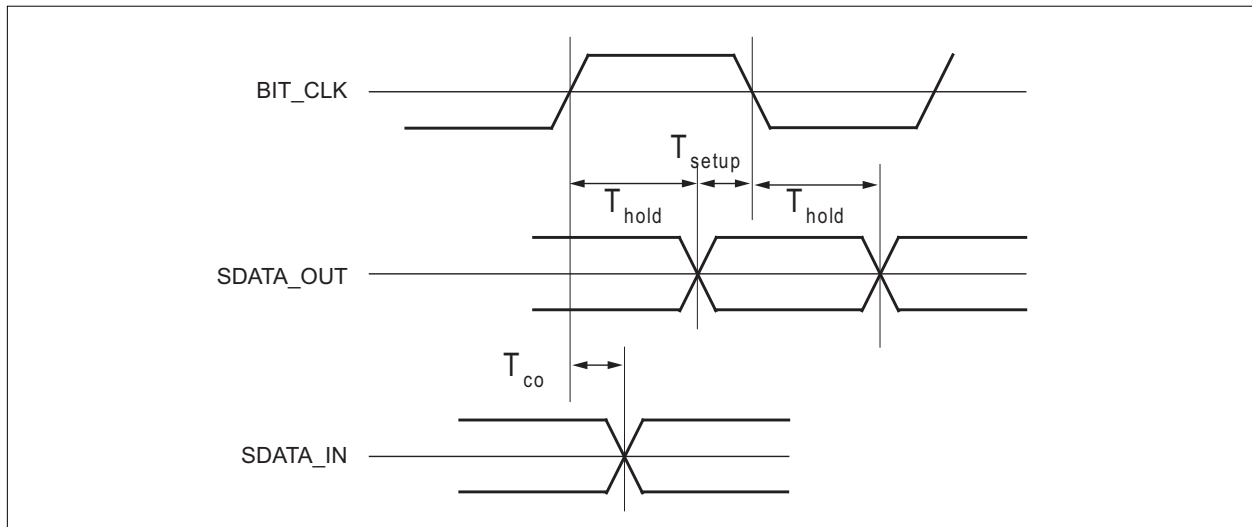

**Figure 10: Data Output and Input Timing Waveforms**

**Table 15: HD Audio Output Valid Delay Timing Parameters**

Parameter	Symbol	Minimum	Typical	Maximum	Units
Output Valid Delay from Rising Edge of BIT_CLK	T <sub>co</sub>	3	-	11	ns

**Note:**

- The timing is for SDATA and SYNC outputs with respect to BIT\_CLK at the device driving the output.
- 50pF external load.

**Table 16: HD Audio Input Setup and Hold Timing Parameters**

Parameter	Symbol	Minimum	Typical	Maximum	Units
Input Setup at Both Rising and Falling Edge of BIT_CLK	T <sub>setup</sub>	5	-	-	ns
Input Hold at Both Rising and Falling Edge of BIT_CLK	T <sub>hold</sub>	5	-	-	ns

**Note:**

- The timing is for SDATA and SYNC inputs with respect to BIT\_CLK at the device latching the input.
- The CX23754 does not impose a maximum value on the system.

# Package Dimensions and Thermal Specifications

The following figure shows the package drawing for the device.

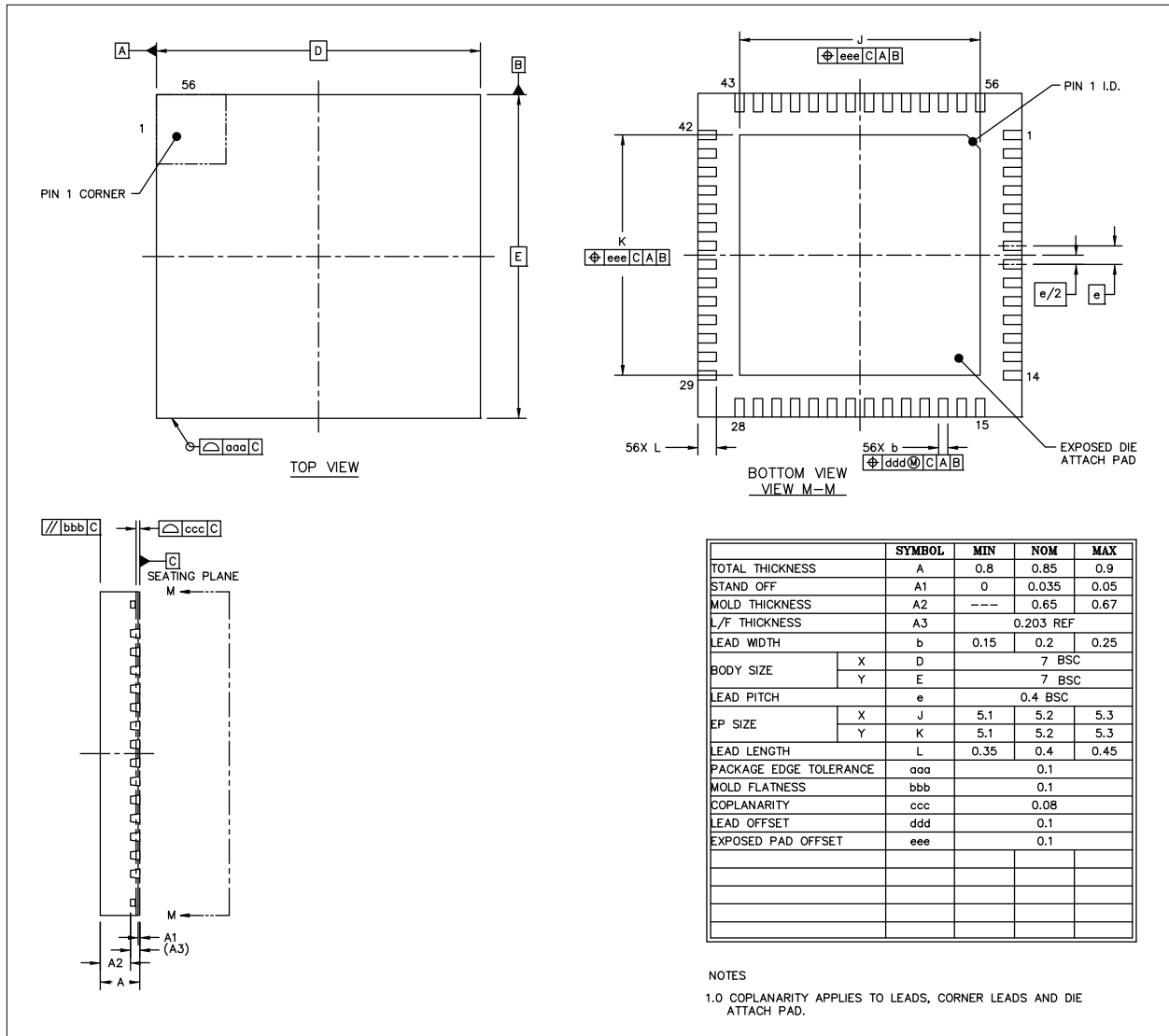

Figure 11: CX23754 56-QFN Package Drawing

The following table defines the thermal specifications.

**Table 17: Thermal Specifications**

Parameter	Symbol	Minimum	Typical	Maximum	Units	Notes
Theta-JA (Junction-to-Ambient Thermal Resistance)	$\theta_{JA}$	-	25.2	-	°C/W	Four-layer PCB with solid ground plane and thermal vias (still air).
Psi-JT (Junction-to-Package Top Thermal Characterization Parameter)	$\Psi_{JT}$	-	0.27	-	°C/W	Four-layer PCB with solid ground plane and thermal vias (still air).

**Note:** Measurements per JEDEC EIA/JESD 51. The  $\theta_{JA}$  of application boards with more than four layers stay the same or improve if the PCB construction is similar to the JEDEC EIA/JESD 51 defined four-layer PCB (2S2P plus vias).

# HD Audio Interface

## Overview

The HD audio interface is a five-pin interface:

- Clock (BIT\_CLK)
- Serial data in (SDATA\_IN)
- Serial data out (SDATA\_OUT)
- SYNC
- RESET#

The clock is provided by the controller at a frequency of 24MHz. Because the SDATA\_OUT signal is provided by the controller and contains data for every edge of the 24MHz clock, the CX23754 must sample data on both rising and falling edges of SDATA\_OUT.

The SYNC signal not only signals the beginning of the 500 clock frame, it designates the beginning of the data for each stream and indicates which stream of data is to be on SDATA\_OUT next (streams do not need to appear in order; the controller may do as it likes). Channels are another way of organizing the serial data. Each stream has at least one channel. Each stream must start with channel 0 and proceed without interruption until all the assigned channels are exhausted. A stereo pair takes two adjacent channels.

The SDATA\_IN signal contains the CX23754 data headed towards the controller, and is only generated on rising edges. This includes information read from the HD audio registers, ADC, and incoming modem data. The stream and channel are indicated before the data is transmitted on SDATA\_IN (refer to Intel's *HD Audio Specification 1.0a* for the format). The SDATA\_IN signal is responsible for knowing the device number, which is the CODEC Address (CAd) in Intel's *HD Audio Specification 1.0a*. During the last clock of the first sync after a Power-on Reset (PoR), the SDATA\_IN is driven high by the CX23754 for one clock cycle. This indicates to the controller the need for a CAd. The CX23754 then stops driving the SDATA\_IN signal, and the controller begins to drive it. The controller drives SDATA\_IN high through the next sync, and the CAd is assigned by the number of clocks after the fall of sync that it takes for the SDATA\_IN to fall. The interface then turns around again, and SDATA\_IN is an output from the CX23754 until reset.

Intel's *HD Audio Specification 1.0a* also contains one other concept of an unsolicited message. Unsolicited messages can occur for a number of reasons, such as timers, ringing phones, answers from the device to a register read, etc. Because the bus has no interrupt, these reasons are taken care of in unsolicited messages. If the controller was not addressing the CAd assigned to the CX23754 during the previous frame and if one of these unsolicited messages is needed (and enabled), the CX23754 uses the first cycles after the sync on SDATA\_IN to alert the controller to the event. Only one event can be signaled in a frame.

The CX23754 only sends the message once, and does not expect any sort of acknowledgment from the controller.

## Verbs

This section describes how this device interacts with the verbs defined in Intel's *HD Audio Specification 1.0a*. Each of the following subsections describe the verb IDs, parameters/payload, and corresponding responses that apply to that node.

Verbs are commands and queries that are passed from the HD audio controller to the CODECs on the HD audio bus. Responses are data passed from the HD audio CODEC to the HD audio controller. All controller verbs must be followed by a CODEC response. Unsolicited responses from the CODEC are data transmitted without a controller verb request.

A 1 in the:

- Valid bit position indicates the Response field contains a valid response.
- UnSol bit position is meaningful only when the Valid bit is set, and indicates that the response is unsolicited rather than in reply to a verb.

The 32 actual response bits vary in format and are each documented in Intel's *HD Audio Specification 1.0a*.

**Note:** For more information regarding the verbs, controller, CODEC commands, and control protocol, refer to Intel's *HD Audio Specification 1.0a* document.

Each node in the CODEC is addressed using a CAAd that is assigned to the CODEC during initialization, and the Node's ID (NID). The concatenation of the CAAd and NID provide a unique address that allows commands to reference a specific node within the audio subsystem.

The entire verb is formed by pre-pending the CAAd and the NID to the verb ID and parameter/payload. In this section's tables and descriptions, the CAAd and NID are not listed as part of the verb.

Register values may have up to five letters included with their default value. These letters indicate which of the possible reset events force the register to its default value. The five letters are as follows:

- P = Power-on reset
- R = HD audio reset pin assertion
- V = Single verb reset
- W = Double verb reset
- D = D-state change reset

Only the letters in the list force the register to its default value.

## Node ID 00: Root Node

Table 18 defines a root note that has one Audio Function Group (AFG). This device is compliant with and follows the guidelines given in Intel's *HD Audio Specification 1.0a* and the *Windows Logo Program Device Requirements* for Windows 7 and Windows 8.

**Table 18: Node 0 Responses**

Description	Verb ID	Parameter	Response	Default Value	Comments
Vendor ID	F00h	00h	14F15111h	-	CX23754.
Revision ID	F00h	02h	0x00100100	-	Revision changes with silicon stepping.
Subordinate Node Count	F00h	04h	0x00010001	-	AFG.

## Node ID 01: Audio Function Group (AFG)

The following table describes an AFG.

**Table 19: Node 01 Responses**

Description	Verb ID	Parameter	Response	Default Value	Comments
Subordinate Node Count	0xF00	0x04	0x0010000F	-	<ul style="list-style-type: none"> <li>Starting node = 10</li> <li>Node count = 15</li> </ul>
Function Group	0xF00	0x05	0x00000101	-	<ul style="list-style-type: none"> <li>AFG</li> <li>Unsolicited capable</li> </ul>
AFG Capabilities	0xF00	0x08	0x00010F0F	-	<ul style="list-style-type: none"> <li>Sample delay in and out is 16</li> <li>PC Beep generation</li> </ul>
PCM Size and Rate	0xF00	0x0A	0x000E0160	-	<ul style="list-style-type: none"> <li>16-bit and 24-bit</li> <li>44.1kHz, 48kHz, and 96kHz</li> </ul>
PCM Format	0xF00	0x0B	0x00000001	-	PCM only.
Supported Power States	0xF00	0x0F	0xE000001F	-	EPSS, clock stop, D0, D1, D2, D3, and D4.
GPIO Count	0xF00	0x11	0xC0000002	-	Two GPIOs, unsolicited message, and wake.
Get Power State	0xF05	0x00	0x00000abc	0x00000633 (P,W)	<ul style="list-style-type: none"> <li>a = Settings reset</li> <li>b = Actual state</li> <li>c = Requested state</li> </ul> The settings reset is cleared by this verb or any write to this node.
Set Power State	0x705	0x0a	0x00000000	-	a = Requested state.
Get Unsolicited	0xF08	0x00	0x000000aa	0x00000000 (P,W)	aa = Unsolicited enable and tag.
Set Unsolicited	0x708	0xaa	0x00000000	-	aa = Unsolicited enable and tag.
Get GPIO Data	0xF15	0x00	0x000000aa	0x00000000 (P,W)	aa = GPIO data.
Set GPIO Data	0x715	0xaa	0x00000000	-	aa = GPIO data.
Get GPIO Enable	0xF16	0x00	0x000000aa	0x00000000 (P,W)	aa = GPIO enable.
Set GPIO Enable	0x716	0xaa	0x00000000	-	aa = GPIO enable.
Get GPIO Direction	0xF17	0x00	0x000000aa	0x00000000 (P,W)	aa = GPIO direction.
Set GPIO Direction	0x717	0xaa	0x00000000	-	aa = GPIO direction.
Get GPIO Wake	0xF18	0x00	0x000000aa	0x00000000 (P,W)	aa = GPIO wake.
Set GPIO Wake	0x718	0xaa	0x00000000	-	aa = GPIO wake.
Get GPIO UM Enable	0xF19	0x00	0x000000aa	0x00000000 (P,W)	aa = Unsolicited message enable.
Set GPIO UM Enable	0x719	0xaa	0x00000000	-	aa = Unsolicited message enable.
Get GPIO Sticky Mask	0xF1A	0x00	0x000000aa	0x00000000 (P,W)	aa = Sticky mask.
Set GPIO Sticky Mask	0x71A	0xaa	0x00000000	-	aa = Sticky mask.

**Table 19: Node 01 Responses (Continued)**

Description	Verb ID	Parameter	Response	Default Value	Comments
Get Default Config	0xF1C– 0xF1F	0x00	0xaabbccdd	0x00000000 (P)	<ul style="list-style-type: none"> <li>aa = Config4</li> <li>bb = Config3</li> <li>cc = Config2</li> <li>dd = Config1</li> </ul>
Set Default Config 1	0x71C	0xaa	0x00000000	-	aa = Config1.
Set Default Config 2	0x71D	0xaa	0x00000000	-	aa = Config2.
Set Default Config 3	0x71E	0xaa	0x00000000	-	aa = Config3.
Set Default Config 4	0x71F	0xaa	0x00000000	-	aa = Config4.
Get Subsystem ID	0xF20– 0xF23	0x00	0xaaaabbcc	0x14F10101 (P)	<ul style="list-style-type: none"> <li>aaaa = Subsystem ID</li> <li>bb = SKU ID</li> <li>cc = Assembly ID</li> </ul>
Set Subsystem ID 1	0x720	0xaa	0x00000000	-	aa = Assembly ID.
Set Subsystem ID 2	0x721	0xaa	0x00000000	-	aa = SKU ID.
Set Subsystem ID 3	0x722	0xaa	0x00000000	-	aa = Subsystem ID low byte.
Set Subsystem ID 4	0x723	0xaa	0x00000000	-	aa = Subsystem ID high byte.
Soft Reset	0x7FF	0x00	0x00000000	-	-

## Nodes 10, 11: DAC 1, 2 Widgets

The following table describes a stereo DAC that supports 16-bit, 20-bit, and 24-bit widths, and 44.1kHz, 48kHz, 96kHz, and 192kHz sample rates.

**Table 20: Node 10 and 11 Responses**

Description	Verb ID	Parameter	Response	Default Value	Comments
Get Converter Format	0xA	0x0000	0x0000aaaa	0x00000031 (P,W)	aaaa = Converter format.
Set Converter Format	0x2	0xaaaa	0x00000000	-	aaaa = Converter format.
Get Amp Gain	0xB80 0xBA0	0x00 0x00	0x000000aa	0x0000004A (P,W)	<ul style="list-style-type: none"> <li>aa = Right gain</li> <li>aa = Left gain</li> </ul>
Set Amp Gain	0x390 0x3A0 0x3B0	0xaa	0x00000000	-	<ul style="list-style-type: none"> <li>aa = Right gain</li> <li>aa = Left gain</li> <li>aa = Right and left gain</li> </ul>
Audio Widget DAC	0xF00	0x09	0x00000C1D	-	DAC—analog.
PCM Size and Rate	0xF00	0x0A	0x000A0060 0x000A0560	0x000A0060	<ul style="list-style-type: none"> <li>16-bit and 24-bit, 44.1kHz and 48kHz</li> <li>96kHz and 192kHz</li> </ul>
PCM Format	0xF00	0x0B	0x00000001	-	PCM only.
Supported Power States	0xF00	0x0F	0x8000000F	-	EPSS, D0, D1, D2, and D3.
Get Output Amp Capabilities	0xF00	0x12	0x80034A4A	-	<ul style="list-style-type: none"> <li>Mute, 1dB step, step 74 is 0dB</li> <li>74 of 80 steps are exposed</li> </ul>
Get Power State	0xF05	0x00	0x00000abc	0x00000433 (P,W)	<ul style="list-style-type: none"> <li>a = Settings reset</li> <li>b = Actual state</li> <li>c = Requested state</li> </ul> <p>The settings reset is cleared by this verb or any write to this node.</p>
Set Power State	0x705	0x0a	0x00000000	-	a = Requested state.
Get Converter Stream/Channel	0xF06	0x00	0x000000ab	0x00000000 (P, R, V, W, D)	<ul style="list-style-type: none"> <li>a = Stream</li> <li>b = Channel position</li> </ul>
Set Converter Stream/Channel	0x706	0xab	0x00000000	-	<ul style="list-style-type: none"> <li>a = Stream</li> <li>b = Channel position</li> </ul>
Get EAPD	0xF0C	0x00	0x0000000a	0x00000000 (P,W)	a = Left/right swap.
Set EAPD	0x70C	0x0a	0x00000000	-	a = Left/right swap.

## Node 12: PC Beep Generator Widget

Table 21 describes a beep generator. PC beep is mixed in with all enabled output ports (including I<sup>2</sup>S) while in D0. When the PC beep input pin is connected but inactive, while not toggling no system noise is injected on the output pins. If the PC beep input is left unconnected, there is no impact on the performance of the output ports.

This is a mono widget. Only the left channel volume request is valid. Any request, read, or write with the right channel is ignored and returns 0x00000000. If both left and right are present in the request, only the value from the left side is used.

The beep gain level range (–4dB to –32dB) is for the speaker port. The default setting is –28dB on the speaker, I<sup>2</sup>S, and –46dB on the headphone.

**Table 21: PC Beep Generator Responses**

Description	Verb ID	Parameter	Response	Default Value	Comments
Get Amp Gain	0xBA0	0x00	0x0000000a	0x00000001 (P,W)	aa = Left gain.
Set Amp Gain	0x3A0 0x3B0	0xaa	0x00000000	-	<ul style="list-style-type: none"> <li>aa = Left gain</li> <li>aa = Left gain</li> </ul>
Audio Widget PC Beep	0xF00	0x09	0x0070000C	-	PC Beep generator with an output amp.
Get Output Amp Capabilities	0xF00	0x12	0x000F0707	-	4dB step, eight steps, and step 8 is –4dB.
Get Beep Generation Control	0xF0A	0x00	0x000000aa	0x00000000 (P,W)	aa = Divider.
Set Beep Generation Control	0x70A	0xaa	0x00000000	-	aa = Divider.

## Node 13, 14: ADC 1, 2 Widget

Table 22 describes a stereo ADC that supports 16-bit and 24-bit widths, and 44.1kHz, 48kHz, and 96kHz sample rates. The ADC has a gain stage and a stereo one-of-four input selector.

Table 22: Node 13 and 14 Responses

Description	Verb ID	Parameter	Response	Default Value	Comments
Get Converter Format	0xA	0x0000	0x0000aaaa	0x00000031 (P,W)	aaaa = Converter format.
Set Converter Format	0x2	0xaaaa	0x00000000	-	aaaa = Converter format.
Get Index 0 Amp Gain	0xB00 0xB20	0x00	0x000000aa 0x000000aa	0x0000004A (P,W)	<ul style="list-style-type: none"> <li>aa = Right gain</li> <li>aa = Left gain</li> </ul>
Get Index 1 Amp Gain	0xB00 0xB20	0x01	0x000000aa 0x000000aa	0x0000004A (P,W)	<ul style="list-style-type: none"> <li>aa = Right gain</li> <li>aa = Left gain</li> </ul>
Get Index 2 Amp Gain	0xB00 0xB20	0x02	0x000000aa 0x000000aa	0x0000004A (P,W)	<ul style="list-style-type: none"> <li>aa = Right gain</li> <li>aa = Left gain</li> </ul>
Get Index 3 Amp Gain	0xB00 0xB20	0x03	0x000000aa 0x000000aa	0x0000004A (P,W)	<ul style="list-style-type: none"> <li>aa = Right gain</li> <li>aa = Left gain</li> </ul>
Set Index 0 Amp Gain	0x350 0x360 0x370	0xaa	0x00000000	-	<ul style="list-style-type: none"> <li>aa = Right gain</li> <li>aa = Left gain</li> <li>aa = Left and right gain</li> </ul>
Set Index 1 Amp Gain	0x351 0x361 0x371	0xaa	0x00000000	-	<ul style="list-style-type: none"> <li>aa = Right gain</li> <li>aa = Left gain</li> <li>aa = Left and right gain</li> </ul>
Set Index 2 Amp Gain	0x352 0x362 0x372	0xaa	0x00000000	-	<ul style="list-style-type: none"> <li>aa = Right gain</li> <li>aa = Left gain</li> <li>aa = Left and right gain</li> </ul>
Set Index 3 Amp Gain	0x353 0x363 0x373	0xaa	0x00000000	-	<ul style="list-style-type: none"> <li>aa = Right gain</li> <li>aa = Left gain</li> <li>aa = Left and right gain</li> </ul>
Audio Widget ADC	0xF00	0x09	0x00100D1B	-	ADC—analog.
PCM Size And Rate	0xF00	0x0A	0x000A0160	-	16-bit and 24-bit/44.1kHz, 48kHz, and 96kHz.
PCM Format	0xF00	0x0B	0x00000001	-	PCM only.
Input Amp Capabilities	0xF00	0x0D	0x8003504A	-	Mute, 1dB step, 80 steps, and step 74 is 0dB.
Connection Length	0xF00	0x0E	0x00000004 0x00000003	-	<ul style="list-style-type: none"> <li>Connected to 4</li> <li>Node 14 reduces to three connections if node 1A is an analog stereo</li> </ul>
Supported Power States	0xF00	0x0F	0x8000000F	-	EPSS, D0, D1, D2, and D3.
Get Connection Select	0xF01	0x00	0x0000000a	0x00000000 (P,W)	a = Connection index.
Set Connection Select	0x701	0x0a	0x00000000	-	a = Connection index.
Get Connection List	0xF02	0x00	0x1E191A18 0x1A151E19 0x00151E19	-	<ul style="list-style-type: none"> <li>Node 13</li> <li>Node 14</li> <li>Node 14 reduces to three connections if node 1A is an analog stereo</li> </ul>

**Table 22: Node 13 and 14 Responses (Continued)**

Description	Verb ID	Parameter	Response	Default Value	Comments
Get Power State	0xF05	0x00	0x00000abc	0x00000433 (P,W)	<ul style="list-style-type: none"> <li>a = Settings reset</li> <li>b = Actual state</li> <li>c = Requested state</li> </ul> The settings reset is cleared by this verb or any write to this node.
Set Power State	0x705	0x0a	0x00000000	-	a = Requested state.
Get Converter Stream/Channel	0xF06	0x00	0x000000ab	0x00000000 (P, R, V, W, D)	<ul style="list-style-type: none"> <li>a = Stream</li> <li>b = Channel position</li> </ul>
Set Converter Stream/Channel	0x706	0xab	0x00000000	-	<ul style="list-style-type: none"> <li>a = Stream</li> <li>b = Channel position</li> </ul>
Get EAPD	0xF0C	0x00	0x0000000a	0x00000000 (P,W)	a = Left/right swap.
Set EAPD	0x70C	0x0a	0x00000000	-	a = Left/right swap.

## Node 15: Mixer Widget

**Table 23: Node 15 Responses**

Description	Verb ID	Parameter	Response	Default Value	Comments
Get Index 0 Amp Gain	0xB00	0x00	0x000000aa	0x00000000 (P,W)	<ul style="list-style-type: none"> <li>a = Right gain</li> <li>a = Left gain</li> </ul>
	0xB20		0x000000aa		
Get Index 1 Amp Gain	0xB00	0x01	0x000000aa	0x00000000 (P,W)	<ul style="list-style-type: none"> <li>a = Right gain</li> <li>a = Left gain</li> </ul>
	0xB20		0x000000aa		
Set Index 0 Amp Gain	0x350	0xaa	0x00000000	-	<ul style="list-style-type: none"> <li>a = Right gain</li> <li>a = Left gain</li> <li>a = Left and right gain</li> </ul>
	0x360				
	0x370				
Set Index 1 Amp Gain	0x351	0xaa	0x00000000	-	<ul style="list-style-type: none"> <li>a = Right gain</li> <li>a = Left gain</li> <li>a = Left and right gain</li> </ul>
	0x361				
	0x371				
Audio Widget Mixer	0xF00	0x09	0x0020050B	-	Mixer with an input amplifier.
Input Amp Capabilities	0xF00	0x0D	0x80034A4A	-	Mute, 1dB step, 74 steps, and step 74 is 0dB.
Connection Length	0xF00	0x0E	0x00000002	-	Connected to 2.
Supported Power States	0xF00	0x0F	0x8000000F	-	EPSS, D0, D1, D2, and D3.
Get Connection List	0xF02	0x00	0x00001110	-	Connected to DAC 1, DAC 2.
Get Power State	0xF05	0x00	0x00000abc	0x00000433 (P,W)	<ul style="list-style-type: none"> <li>a = Settings reset</li> <li>b = Actual state</li> <li>c = Requested state</li> </ul> <p>The settings reset is cleared by this verb or any write to this node.</p>
Set Power State	0x705	0x0a	0x00000000	-	a = Requested state.

## Node 16: Port A/Vendor Widget

The following table describes a pin that has selectable headphone or line drive and supports jack sensing.

**Table 24: Node 16 Responses**

Description	Verb ID	Parameter	Response	Default Value	Comments
Audio Widget Pin	0xF00	0x09	0x00400581 0x00F00000	-	<ul style="list-style-type: none"> <li>Pin—analog</li> <li>Vendor widget</li> <li>Universal jack mode</li> </ul>
Get Pin Capabilities	0xF00	0x0C	0x0000001C	-	Output, HP, jack sense.
Connection Length	0xF00	0x0E	0x00000002	-	Connected to 2.
Supported Power States	0xF00	0x0F	0x8000000F	-	EPSS, D0, D1, D2, and D3.
Get Connection	0xF01	0x00	0x0000000a	0x00000000 (P,W)	DAC 1 selected.
Set Connection	0x701	0x0a	0x00000000	-	<ul style="list-style-type: none"> <li>0 = DAC 1</li> <li>1 = DAC 2</li> </ul>
Get Connection List	0xF02	0x00	0x00001110	-	DAC 1, 2.
Get Power State	0xF05	0x00	0x00000abc	0x00000433 (P,W)	<ul style="list-style-type: none"> <li>a = Settings reset</li> <li>b = Actual state</li> <li>c = Requested state</li> </ul> The settings reset is cleared by this verb or any write to this node.
Set Power State	0x705	0x0a	0x00000000	-	a = Requested state.
Get Pin Control	0xF07	0x00	0x000000a0	0x000000C0 (P,W)	a = Headphone and output enable.
Set Pin Control	0x707	0xa0	0x00000000	-	a = Headphone and output enable.
Get Unsolicited Response	0xF08	0x00	0x000000aa	0x00000000 (P,W)	aa = Unsolicited enable and tag.
Set Unsolicited Response	0x708	0xaa	0x00000000	-	aa = Unsolicited enable and tag.
Get Pin Sense	0xF09	0x00	0xa0000000	-	<ul style="list-style-type: none"> <li>a = Presence detect</li> <li>8 = Present</li> <li>0 = Missing</li> </ul>
Get Default Config	0xF1C– 0xF1F	0x00	0xaabbccdd	0x0421401F (P)	<ul style="list-style-type: none"> <li>aa = Config4</li> <li>bb = Config3</li> <li>cc = Config2</li> <li>dd = Config1</li> </ul>
Set Default Config 1	0x71C	0xaa	0x00000000	-	aa = Config1.
Set Default Config 2	0x71D	0xaa	0x00000000	-	aa = Config2.
Set Default Config 3	0x71E	0xaa	0x00000000	-	aa = Config3.
Set Default Config 4	0x71F	0xaa	0x00000000	-	aa = Config4.

## Node 17: Port G

The following pin accepts a stereo signal and drives stereo speakers.

**Table 25: Node 17 Responses**

Description	Verb ID	Parameter	Response	Default Value	Comments
Audio Widget Pin	0xF00	0x09	0x00400501	-	Pin—analog.
Get Pin Capabilities	0xF00	0x0C	0x00000010	-	Output.
Connection Length	0xF00	0x0E	0x00000002	-	Connected to 2.
Supported Power States	0xF00	0x0F	0x8000000F	-	EPSS D0, D1, D2, and D3.
Get Connection	0xF01	0x00	0x0000000a	0x00000000 (P,W)	DAC 1 selected.
Set Connection	0x701	0x0a	0x00000000	-	<ul style="list-style-type: none"> <li>0 = DAC 1</li> <li>1 = DAC 2</li> </ul>
Get Connection List	0xF02	0x00	0x00001110	-	Connected to DAC 1, 2.
Get Power State	0xF05	0x00	0x00000abc	0x00000433 (P,W)	<ul style="list-style-type: none"> <li>a = Settings reset</li> <li>b = Actual state</li> <li>c = Requested state</li> </ul> The settings reset is cleared by this verb or any write to this node.
Set Power State	0x705	0x0a	0x00000000	-	a = Requested state.
Get Pin Control	0xF07	0x00	0x000000a0	0x00000040 (P,W)	a = Output enable.
Set Pin Control	0x707	0xa0	0x00000000	-	a = Output enable.
Get Default Config	0xF1C– 0xF1F	0x00	0xaabbccdd	0x90170010 (P)	<ul style="list-style-type: none"> <li>aa = Config4</li> <li>bb = Config3</li> <li>cc = Config2</li> <li>dd = Config1</li> </ul>
Set Default Config 1	0x71C	0xaa	0x00000000	-	aa = Config1.
Set Default Config 2	0x71D	0xaa	0x00000000	-	aa = Config2.
Set Default Config 3	0x71E	0xaa	0x00000000	-	aa = Config3.
Set Default Config 4	0x71F	0xaa	0x00000000	-	aa = Config4.

## Node 18: Port B Widget

Table 26 describes a stereo input pin that can be configured to be a line input or a microphone input. There is a microphone boost control and micbias. This pin supports jack sensing.

**Table 26: Node 18 Response**

Description	Verb ID	Parameter	Response	Default Value	Comments
Get Amp Gain	0xB00 0xB20	0x00	0x000000aa 0x000000aa	0x00000000 (P,W)	<ul style="list-style-type: none"> <li>aa = Right gain</li> <li>aa = Left gain</li> </ul>
Set Amp Gain	0x350 0x360 0x370	0xaa	0x00000000	-	<ul style="list-style-type: none"> <li>aa = Right gain</li> <li>aa = Left gain</li> <li>aa = Left and right gain</li> </ul>
Audio Widget Pin	0xF00	0x09	0x0040048B 0x0040058B	-	<ul style="list-style-type: none"> <li>Pin—analog</li> <li>Connection list (universal jack mode)</li> </ul>
Get Pin Capabilities	0xF00	0x0C	0x00000024 0x0000003C 0x00001124 0x0000113C	No bias Headset mode Bias mapped HP and bias	<ul style="list-style-type: none"> <li>Input, jack sense</li> <li>In/out, jack sense</li> <li>Vref, Input, jack sense</li> <li>Everything above</li> </ul>
Input Amp Capabilities	0xF00	0x0D	0x002F0300	-	12dB step, four steps, and step 0 is 0dB.
Connection Length	0xF00	0x0E	0x00000002	Headset mode	Connected to 2.
Supported Power States	0xF00	0x0F	0x8000000F	-	EPSS, D0, D1, D2, and D3.
Get Connection	0xF01	0x00	0x0000000a	0x00000000 (P,W)	<ul style="list-style-type: none"> <li>DAC 1 selected</li> <li>Headset mode only</li> </ul>
Set Connection	0x701	0x0a	0x00000000	-	<ul style="list-style-type: none"> <li>0 = DAC 1</li> <li>1 = DAC 2</li> <li>Headset mode only</li> </ul>
Get Connection List	0xF02	0x00	0x00001110	-	<ul style="list-style-type: none"> <li>DAC 1, 2</li> <li>Headset mode only</li> </ul>
Get Power State	0xF05	0x00	0x00000abc	0x00000433 (P,W)	<ul style="list-style-type: none"> <li>a = Settings reset</li> <li>b = Actual state</li> <li>c = Requested state</li> </ul> The settings reset is cleared by this verb or any write to this node.
Set Power State	0x705	0x0a	0x00000000	-	a = Requested state.
Get Pin Control	0xF07	0x00	0x000000aa	0x00000000 (P,W)	Vref, aa = Input enable output, HP (headset mode).
Set Pin Control	0x707	0xaa	0x00000000	-	Vref, aa = Input enable output, HP (headset mode).
Get Unsolicited Response	0xF08	0x00	0xaa	0x00000000 (P,W)	aa = Unsolicited enable and tag.
Set Unsolicited Response	0x708	0xaa	0x00000000	-	aa = Unsolicited enable and tag.
Get Pin Sense	0xF09	0x00	0xa0000000	-	<ul style="list-style-type: none"> <li>a = Presence detect</li> <li>8 = Present</li> <li>0 = Missing</li> </ul>

**Table 26: Node 18 Response (Continued)**

Description	Verb ID	Parameter	Response	Default Value	Comments
Get Default Config	0xF1C– 0xF1F	0x00	0xaabbccdd	0x048130F0 (P)	<ul style="list-style-type: none"> <li>• aa = Config4</li> <li>• bb = Config3</li> <li>• cc = Config2</li> <li>• dd = Config1</li> </ul>
Set Default Config 1	0x71C	0xaa	0x00000000	-	aa = Config1.
Set Default Config 2	0x71D	0xaa	0x00000000	-	aa = Config2.
Set Default Config 3	0x71E	0xaa	0x00000000	-	aa = Config3.
Set Default Config 4	0x71F	0xaa	0x00000000	-	aa = Config4.

## Node 19: Port D Widget

Table 27 describes a stereo pin that can be configured to be a line input or a microphone input. There is a microphone boost control and micbias.

Table 27: Node 19 Response

Description	Verb ID	Parameter	Response	Default Value	Comments
Get Amp Gain	0xB00 0xB20	0x00	0x000000aa 0x000000aa	0x00000000 (P,W)	<ul style="list-style-type: none"> <li>aa = Right gain</li> <li>aa = Left gain</li> </ul>
Set Amp Gain	0x350 0x360 0x370	0xaa	0x00000000	-	<ul style="list-style-type: none"> <li>aa = Right gain</li> <li>aa = Left gain</li> <li>aa = Left and right gain</li> </ul>
Audio Widget Pin	0xF00	0x09	0x0040048B	-	Pin—analog.
Get Pin Capabilities	0xF00	0x0C	0x00001124 0x00001120	Headset enabled	<ul style="list-style-type: none"> <li>Vref, in, jack sense</li> <li>Vref, in</li> </ul>
Input Amp Capabilities	0xF00	0x0D	0x002F0300	-	12dB step, four steps, and step 0 is 0dB.
Supported Power States	0xF00	0x0F	0x8000000F	-	EPSS, D0, D1, D2, and D3.
Get Power State	0xF05	0x00	0x00000abc	0x00000433 (P,W)	<ul style="list-style-type: none"> <li>a = Settings reset</li> <li>b = Actual state</li> <li>c = Requested state</li> </ul> <p>The settings reset is cleared by this verb or any write to this node.</p>
Set Power State	0x705	0x0a	0x00000000	-	a = Requested state.
Get Pin Control	0xF07	0x00	0x000000aa	0x00000000 (P,W)	aa = Vref, input enable.
Set Pin Control	0x707	0xaa	0x00000000	-	aa = Vref, input enable.
Get Unsolicited Response	0xF08	0x00	0xaa	0x00000000 (P,W)	aa = Unsolicited enable and tag.
Set Unsolicited Response	0x708	0xaa	0x00000000	-	aa = Unsolicited enable and tag.
Get Pin Sense	0xF09	0x00	0xa0000000	-	<ul style="list-style-type: none"> <li>a = Presence detect</li> <li>8 = Present</li> <li>0 = Missing</li> </ul>
Get Default Config	0xF1C- 0xF1F	0x00	0xaabbccdd	0x04A190F0 (P)	<ul style="list-style-type: none"> <li>aa = Config4</li> <li>bb = Config3</li> <li>cc = Config2</li> <li>dd = Config1</li> </ul>
Set Default Config 1	0x71C	0xaa	0x00000000	-	aa = Config1.
Set Default Config 2	0x71D	0xaa	0x00000000	-	aa = Config2.
Set Default Config 3	0x71E	0xaa	0x00000000	-	aa = Config3.
Set Default Config 4	0x71F	0xaa	0x00000000	-	aa = Config4.

## Node 1A: Port C Widget

Port C is either an internal digital or analog microphone. The analog microphone has an option to send the left channel to both a left and right, mono microphone connection. Analog microphone is the reset default.

**Table 28: Node 1A Responses**

Description	Verb ID	Parameter	Response	Default Value	Comments
Get Amp Gain	0xB00 0xB20	0x00	0x000000aa 0x000000aa	0x00000000 (P,W)	<ul style="list-style-type: none"> <li>aa = Right gain</li> <li>aa = Left gain</li> </ul>
Set Amp Gain	0x350 0x360 0x370	0xaa	0x00000000	-	<ul style="list-style-type: none"> <li>aa = Right gain</li> <li>aa = Left gain</li> <li>aa = Left and right gain</li> </ul>
Audio Widget Pin	0xF00	0x09	0x0040048B	-	Pin—analog.
Get Pin Capabilities	0xF00	0x0C	0x00001120 0x00000020	-	<ul style="list-style-type: none"> <li>Analog—Vref, input</li> <li>Digital—Input (digital microphone mode)</li> </ul>
Input Amp Capabilities	0xF00	0x0D	0x002F0300	-	12dB step, four steps, and step 0 is 0dB.
Supported Power States	0xF00	0x0F	0x8000000F	-	EPSS D0, D1, D2, and D3.
Get Power State	0xF05	0x00	0x00000abc	0x00000433 (P,W)	<ul style="list-style-type: none"> <li>a = Settings reset</li> <li>b = Actual state</li> <li>c = Requested state</li> </ul> <p>The settings reset is cleared by this verb or any write to this node.</p>
Set Power State	0x705	0x0a	0x00000000	-	a = Requested state.
Get Pin Control	0xF07	0x00	0x000000aa	0x00000000 (P,W)	<ul style="list-style-type: none"> <li>aa = Vref, input enable</li> <li>aa = Input enable (digital microphone mode)</li> </ul>
Set Pin Control	0x707	0xaa	0x00000000	-	<ul style="list-style-type: none"> <li>aa = Vref, input enable</li> <li>aa = Input enable (digital microphone mode)</li> </ul>
Get Default Config	0xF1C– 0xF1F	0x00	0xaabbccdd	0x90A700F0 (P)	<ul style="list-style-type: none"> <li>aa = Config4</li> <li>bb = Config3</li> <li>cc = Config2</li> <li>dd = Config1</li> </ul>
Set Default Config 1	0x71C	0xaa	0x00000000	-	aa = Config1.
Set Default Config 2	0x71D	0xaa	0x00000000	-	aa = Config2.
Set Default Config 3	0x71E	0xaa	0x00000000	-	aa = Config3.
Set Default Config 4	0x71F	0xaa	0x00000000	-	aa = Config4.

## Node 1B: Vendor Widget—EQ and DRC Settings

Table 29 describes a vendor-specific node. This node is used for writing and reading coefficients for the integrated EQ/DRC engine in the CODEC. A tool is available that allows easy tuning of the EQ and the DRC, and generates the verb tables needed for BIOS programming.

**Table 29: Node 1B Responses**

Description	Verb ID	Parameter	Response	Default Value	Comments
Get EQ Configuration	0xA	0xa000	0x00000bbb	0x00000000 (P)	<ul style="list-style-type: none"> <li>a = Register number</li> <li>bbb = 12-bit value</li> </ul>
	0x2	0xabbb	0x00000000	-	<ul style="list-style-type: none"> <li>a = Register number</li> <li>bbb = 12-bit value</li> </ul>
Set EQ Configuration	0xB	0xa000	0x00000bbb	0x00000000 (P)	<ul style="list-style-type: none"> <li>a = Register number</li> <li>bbb = 12-bit value</li> </ul>
	0x3	0xabbb	0x00000000	-	<ul style="list-style-type: none"> <li>a = Register number</li> <li>bbb = 12-bit value</li> </ul>
	0xC	0xa000	0x00000bbb	0x00000000 (P)	<ul style="list-style-type: none"> <li>a = Register number</li> <li>bbb = 12-bit value</li> </ul>
	0x4	0xabbb	0x00000000	-	<ul style="list-style-type: none"> <li>a = Register number</li> <li>bbb = 12-bit value</li> </ul>
Audio Widget Vendor	F00	0x09	0x00F00000	-	-

## Node 1D: Port E Widget—I<sup>2</sup>S Output

Table 30 describes a pin that can be a headphone or line-out, and supports jack sensing.

- MCLK output = Selectable 24MHz, 12MHz (default), 24.576MHz, and 12.288MHz
- LRCK output = 48kHz
- BCLK output = Selectable 1.536MHz (16-bit samples) or 3.072MHz (default, 24-bit samples)

**Table 30: Node 1D Responses**

Description	Verb ID	Parameter	Response	Default Value	Comments
Audio Widget Pin	0xF00	0x09	0x00400581	-	Pin—analog.
Get Pin Capabilities	0xF00	0x0C	0x0000001C	-	Output, HP, jack sense.
Connection Length	0xF00	0x0E	0x00000002	-	Connected to two widgets.
Supported Power States	0xF00	0x0F	0x8000000F	-	EPSS, D0, D1, D2, and D3.
Get Connection	0xF01	0x00	0x0000000a	0x00000000 (P,W)	DAC 1 selected.
Set Connection	0x701	0x0a	0x00000000	-	<ul style="list-style-type: none"> <li>• 0 = DAC 1</li> <li>• 1 = DAC 2</li> </ul>
Get Connection List	0xF02	0x00	0x00001110	-	DAC 1, 2.
Get Power State	0xF05	0x00	0x00000abc	0x00000433 (P,W)	<ul style="list-style-type: none"> <li>• a = Settings reset</li> <li>• b = Actual state</li> <li>• c = Requested state</li> </ul> The settings reset is cleared by this verb or any write to this node.
Set Power State	0x705	0x0a	0x00000000	-	a = Requested state.
Get Pin Control	0xF07	0x00	0x000000aa	0x00000000 (P,W)	aa = Headphone, output enable.
Set Pin Control	0x707	0xaa	0x00000000		aa = Headphone, output enable.
Get Unsolicited Response	0xF08	0x00	0x000000aa	0x00000000 (P,W)	aa = Unsolicited enable and tag.
Set Unsolicited Response	0x708	0xaa	0x00000000	-	aa = Unsolicited enable and tag.
Get Pin Sense	0xF09	0x00	0xa0000000	-	<ul style="list-style-type: none"> <li>• a = Presence detect</li> <li>• 8 = Present</li> <li>• 0 = Missing</li> </ul>
Get Default Config	0xF1C– 0xF1F	0x00	0xaabbccdd	Line 0x240140F0 (P)	<ul style="list-style-type: none"> <li>• aa = Config4</li> <li>• bb = Config3</li> <li>• cc = Config2</li> <li>• dd = Config1</li> </ul>
Set Default Config 1	0x71C	0xaa	0x00000000	-	aa = Config1.
Set Default Config 2	0x71D	0xaa	0x00000000	-	aa = Config2.
Set Default Config 3	0x71E	0xaa	0x00000000	-	aa = Config3.
Set Default Config 4	0x71F	0xaa	0x00000000	-	aa = Config4.

Node 1E: Port F Widget – I<sup>2</sup>S Input

The following table describes a stereo line input or microphone input with jack sensing.

**Table 31: Node 1E Response**

Description	Verb ID	Parameter	Response	Default Value	Comments
Get Amp Gain	0xB00 0xB20	0x00	0x000000aa 0x000000aa	0x00000000 (P,W)	<ul style="list-style-type: none"> <li>aa = Right gain</li> <li>aa = Left gain</li> </ul>
Set Amp Gain	0x350 0x360 0x370	0xaa	0x00000000	-	<ul style="list-style-type: none"> <li>aa = Right gain</li> <li>aa = Left gain</li> <li>aa = Left &amp; Right gain</li> </ul>
Audio Widget Pin	0xF00	0x09	0x0040048B	-	Pin—analog.
Get Pin Capabilities	0xF00	0x0C	0x00000024	-	Input, jack sense.
Input Amp Capabilities	0xF00	0x0D	0x002F0300	-	12dB step, four steps, and step 0 is 0dB.
Supported Power States	0xF00	0x0F	0x8000000F	-	EPSS D0, D1, D2, and D3.
Get Power State	0xF05	0x00	0x00000abc	0x00000433 (P,W)	<ul style="list-style-type: none"> <li>a = Settings reset</li> <li>b = Actual state</li> <li>c = Requested state</li> </ul> <p>The settings reset cleared by this verb or any write to this node.</p>
Set Power State	0x705	0x0a	0x00000000	-	a = Requested state.
Get Pin Control	0xF07	0x00	0x000000a0	0x00000000 (P,W)	a = Input enable.
Set Pin Control	0x707	0xa0	0x00000000	-	a = Input enable.
Get Unsolicited Response	0xF08	0x00	0xaa	0x00000000 (P,W)	aa = Unsolicited enable and tag.
Set Unsolicited Response	0x708	0xaa	0x00000000	-	aa = Unsolicited enable and tag.
Get Pin Sense	0xF09	0x00	0xa0000000	-	<ul style="list-style-type: none"> <li>a = Presence detect</li> <li>8 = Present</li> <li>0 = Missing</li> </ul>
Get Default Config	0xF1C– 0xF1F	0x00	0xaabbccdd	0x248130F0 (P)	<ul style="list-style-type: none"> <li>aa = Config4</li> <li>bb = Config3</li> <li>cc = Config2</li> <li>dd = Config1</li> </ul>
Set Default Config 1	0x71C	0xaa	0x00000000	-	aa = Config1.
Set Default Config 2	0x71D	0xaa	0x00000000	-	aa = Config2.
Set Default Config 3	0x71E	0xaa	0x00000000	-	aa = Config3.
Set Default Config 4	0x71F	0xaa	0x00000000	-	aa = Config4.

## Ordering Information

The following table shows the ordering information (device order part number and the supported functions).

**Table 32: CX23754 Ordering Information and Functions**

Model/Order/Part Numbers				Supported Functions		Operating Temperature
Device Order Number	Audio CODEC Part Number	Revision	Audio CODEC Package Type	AudioSmart Class-D	Number of DACs/ADCs	
CX23754-31Z	CX23754	-31Z	56-QFN	Yes	4/4	0 to 70°C

**Note:** All devices are lead-free (Pb-free) and RoHS-compliant, and are compatible with leaded re-flow processes. Contact the local Conexant Sales office for advanced software options.

[www.conexant.com](http://www.conexant.com)

Headquarters: 1901 Main Street, Suite 300 Irvine, CA,92614

General Information: U.S. and Canada: 888-855-4562 | International: 1 + 949-483-3000



© 2015 Conexant Systems, Inc.

Information in this document is provided in connection with Conexant Systems, Inc. ("Conexant") products. These materials are provided by Conexant as a service to its customers and may be used for informational purposes only. Conexant assumes no responsibility for errors or omissions in these materials. Conexant may make changes to this document at any time, without notice. Conexant advises all customers to ensure that they have the latest version of this document and to verify, before placing orders, that information being relied on is current and complete. Conexant makes no commitment to update the information and shall have no responsibility whatsoever for conflicts or incompatibilities arising from future changes to its specifications and product descriptions.

No license, express or implied, by estoppel or otherwise, to any intellectual property rights is granted by this document. Except as provided in Conexant's Terms and Conditions of Sale for such products, Conexant assumes no liability whatsoever.

THESE MATERIALS ARE PROVIDED "AS IS" WITHOUT WARRANTY OF ANY KIND, EITHER EXPRESS OR IMPLIED, RELATING TO SALE AND/OR USE OF CONEXANT PRODUCTS INCLUDING LIABILITY OR WARRANTIES RELATING TO FITNESS FOR A PARTICULAR PURPOSE, CONSEQUENTIAL OR INCIDENTAL DAMAGES, MERCHANTABILITY, OR INFRINGEMENT OF ANY PATENT, COPYRIGHT, OR OTHER INTELLECTUAL PROPERTY RIGHT. CONEXANT FURTHER DOES NOT WARRANT THE ACCURACY OR COMPLETENESS OF THE INFORMATION, TEXT, GRAPHICS, OR OTHER ITEMS CONTAINED WITHIN THESE MATERIALS. CONEXANT SHALL NOT BE LIABLE FOR ANY SPECIAL, INDIRECT, INCIDENTAL, OR CONSEQUENTIAL DAMAGES, INCLUDING WITHOUT LIMITATION, LOST REVENUES OR LOST PROFITS, WHICH MAY RESULT FROM THE USE OF THESE MATERIALS.

Conexant products are not intended for use in medical, lifesaving or life sustaining applications. Conexant customers using or selling Conexant products for use in such applications do so at their own risk and agree to fully indemnify Conexant for any damages resulting from such improper use or sale.

The following are trademarks of Conexant Systems, Inc.: Conexant® and the Conexant© symbol, SmartAudio, SmartJack, SmartCD, and SmartDAA®. Product names or services listed in this publication are for identification purposes only, and may be trademarks of third parties. Third-party brands and names are the property of their respective owners.

For additional disclaimer information, consult Conexant's Legal Information posted at [www.conexant.com](http://www.conexant.com) which is incorporated by reference.

**Reader Response:** Conexant strives to produce quality documentation and welcomes your feedback. Please send comments and suggestions to [conexant.tech.pubs@conexant.com](mailto:conexant.tech.pubs@conexant.com). For technical questions, contact your local Conexant sales office or field applications engineer.