

DASH NO	CABLES ACCOMMODATED	A DIM	B DIM	C FLATS	D FLATS	E DIA	ASSEMBLE PER
-7	TRC-50-2 TRC-75-2	1.135	.096	.438	.438	.500	TAI-189
-8	8227, BELDEN	1.716	.130	.625	.688	.750	TAI-103
-9	TWC-78-2 TWC-124-2	1.135	.096	.438	.438	.500	TAI-102
-A9	BL782, TIMES BL982, TIMES BL1242, TIMES			△	△		
-10	RG-22 754E, AT&T						
-11	760A, AT&T	1.716	.130	.625	.688	.750	TAI-103
-12	16 PEVL, AT&T V1-AL, GENERAL						TAI-128
-13	TRF-59, TIMES						TAI-129
-13A	8232, BELDEN						TAI-165
-14	8233, BELDEN						TAI-129
-23	250-3884, MICRODOT						TAI-189
-24	202-3934, MICRODOT						TAI-102
-24A	9530A5117, RAYCHEM	TAI-189					
-25	T-43M, GENERAL	1.135	.096	.438	.438	.500	TAI-102
-25A	5021H5331, RAYCHEM						TAI-189
-26	7028A5518, RAYCHEM						TAI-189
-27	T19TPSJ2619EN, WOVEN 202-3927, MICRODOT 202-3942, MICRODOT						TAI-102
-29	TWC-78-1/TWC-124-1A						TAI-102
-30	761A, AT&T 8441, BELDEN						TAI-189
-32	TRC-50-1						TAI-189
-33	TRC-75-1						TAI-189
-42	21-204, ESSEX 4463, CONSOLIDATED						TAI-189
-43	250-4044/250-4045 293-3930, MICRODOT						TAI-102
-45	M27500-22TE2T14 1100-66F, STANDARD	TAI-102					
-46	9860, BELDEN	1.716	.130	.625	.688	.750	TAI-103
-47	M17/176-00002	1.135	.096	.438	.438	.500	TAI-102
-49	TWAC-78-1F2						
-54	89207, BELDEN	1.716	.130	.625	.688	.750	TAI-102
-55	89272, BELDEN	1.135	.096	.438	.438	.500	TAI-189
-56	GC875GC1, GRUMMAN						TAI-189
-57	GC875GB1, GRUMMAN						TAI-189
-58	GC875TM24H, GRUMMAN						TAI-102
-59	GC875LN1, GRUMMAN						TAI-189
-60	M17/177, THERMATICS 380-10045, BOEING						TAI-189
-64	7528A5314, RAYCHEM						

DATA CONTAINED IN THIS DOCUMENT IS PROPRIETARY TO TROMPETER ELECTRONICS, INC. AND SHALL NOT BE DISCLOSED, COPIED OR USED FOR PROCUREMENT OR MANUFACTURE WITHOUT EXPRESS WRITTEN PERMISSION OF TROMPETER ELECTRONICS, INC.

REVISIONS		310-0025	SH 1
REV	DESCRIPTION	DATE	APPROVED
U	REVISED PER ECO 14778	11-5-02	AM

CABLE ENTRY			
DASH NO	DIA	DASH NO	DIA
-7	.274	-29	.191
-8	.345	-30	.235
-9	.285	-32	.191
-A9	.285	-33	.217
-10	.455	-42	.300
-11	.347	-43	.200
-12	.485	-45	.183
-13	.362	-46	.475
-13A	.352	-47	.164
-14	.490	-49	.132
-23	.183	-54	.323
-24	.191	-55	.250
-24A	.200	-56	.191
-25	.285	-57	.191
-25A	.285	-58	.198
-26	.191	-59	.217
-27	.145	-60	.217
		-64	.183

FIG 1 △
-9 SHOWN

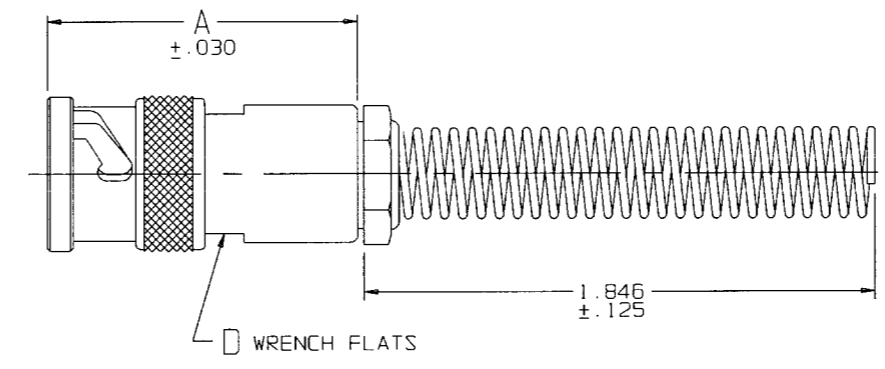
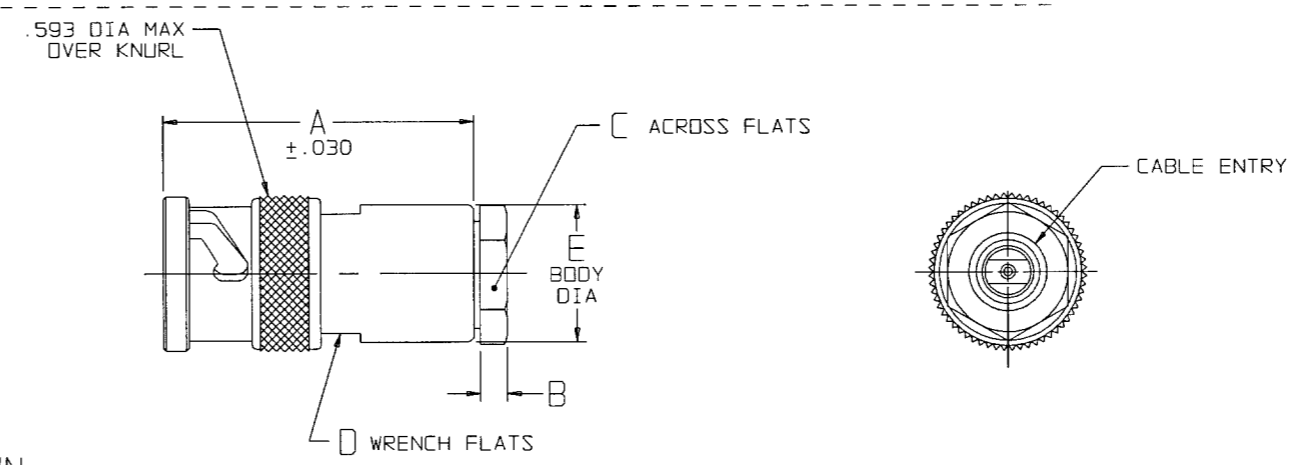
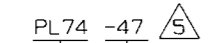

FIG 2 △
-9 SHOWN



RED INDICATES ORIGINAL

6. EXAMPLE OF A COMPLETE MODEL NO.



BASIC MODEL NO. | DASH NO.

△ IF BEND RELIEF SPRING REQD (SEE FIG 1)
ADD SUFFIX "BR" TO MODEL NO
(NOT AVAILABLE WITH CABLE GROUPS -8, -10, -11,
-12, -13, -13A, -14, -46 & -54)

△ CLAMP NUT OMITTED

△ 2-LUG BAYONET CONCENTRIC TWINAX/TRIAX TRB CABLE PLUG

2. FINISH: TFS-1A (NICKEL)

1. ALL DIM ARE IN INCHES

TYPE △	DASH NO/CABLE GROUP																
TWINAX	-8	-9	-A9	-10	-11	-12	-24	-25	-27	-29	-30	-45	-46	-47	-49	-54	-55
TRIAX	-7	-13	-13A	-14	-23	-24A	-25A	-26	-32	-33	-42	-43	-56	-57	-59	-60	-64
QUADRIX	-58																

INTERPRET DRAWING PER MIL-STD-100 DIMENSIONS ARE IN INCHES AND INCLUDE FINISH THICKNESS UNLESS OTHERWISE SPECIFIED	TOL: UNLESS SPECIFIED .XX .XXX ± .005 .XXXX ANGLS		TITLE: PL74/PL74BR			
DRAWN: AAH DATE: 11-4-02 QUALITY: [Signature] DATE: 11-5-02 FINISH: [Signature] DATE: 11-5-02	MATERIAL: [Signature] DATE: 11-5-02			SIZE: B CAGE CODE: 14949 DRAWING NO.: 310-0025 REV.: U		
305-0515	NEXT ASSY	310-0025U	DO NOT SCALE DWG	SCALE: NONE	DATE: 3/27/78	SHEET: 1C