

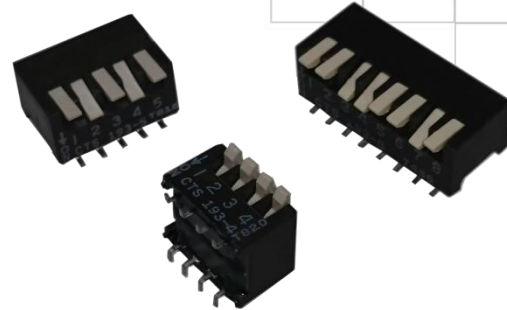

Series 193

Side Actuated DIP Switch

- Coplanarity: 0.1mm/.004" maximum
- Enclosed actuators shield contacts from foreign particles throughout life of switch
- Integral terminal and contact locked into high temperature plastic base
- Gold plated contacts for long-term contact corrosion resistance



Description

The gold plated contact lock-over-center design provides positive detent action for CTS 193 Series. Optimized active contact design incorporates a high contact force, dimple wiping action interface, making it the ideal choice for any network or security system.

Ordering Information

Series	Number of Actuator	Actuator Length	Bottom Seal	Package	Shipping Position																													
193-	XX	M	S	R	N																													
	<table border="1"> <thead> <tr> <th>Code</th> <th>No. of switch positions</th> </tr> </thead> <tbody> <tr><td>2</td><td>2 positions</td></tr> <tr><td>3</td><td>3 positions</td></tr> <tr><td>4</td><td>4 positions</td></tr> <tr><td>5</td><td>5 positions</td></tr> <tr><td>6</td><td>6 positions</td></tr> <tr><td>7</td><td>7 positions</td></tr> <tr><td>8</td><td>8 positions</td></tr> <tr><td>9</td><td>9 positions</td></tr> <tr><td>10</td><td>10 positions</td></tr> </tbody> </table>	Code	No. of switch positions	2	2 positions	3	3 positions	4	4 positions	5	5 positions	6	6 positions	7	7 positions	8	8 positions	9	9 positions	10	10 positions	<table border="1"> <thead> <tr> <th>Code</th> <th>Spec.</th> </tr> </thead> <tbody> <tr> <td>M</td> <td>Medium actuator (1.14mm/.045")</td> </tr> </tbody> </table>	Code	Spec.	M	Medium actuator (1.14mm/.045")		<table border="1"> <thead> <tr> <th>Code</th> <th>Spec.</th> </tr> </thead> <tbody> <tr> <td>Blank</td> <td>Ship at OFF position</td> </tr> <tr> <td>N</td> <td>Ship at ON position</td> </tr> </tbody> </table>	Code	Spec.	Blank	Ship at OFF position	N	Ship at ON position
Code	No. of switch positions																																	
2	2 positions																																	
3	3 positions																																	
4	4 positions																																	
5	5 positions																																	
6	6 positions																																	
7	7 positions																																	
8	8 positions																																	
9	9 positions																																	
10	10 positions																																	
Code	Spec.																																	
M	Medium actuator (1.14mm/.045")																																	
Code	Spec.																																	
Blank	Ship at OFF position																																	
N	Ship at ON position																																	
				<table border="1"> <thead> <tr> <th>Code</th> <th>Spec.</th> </tr> </thead> <tbody> <tr> <td>Blank</td> <td>Anti-static tube packaging</td> </tr> <tr> <td>R</td> <td>Tape and reel packaging (Not available for 7 position switch)</td> </tr> </tbody> </table>	Code	Spec.	Blank	Anti-static tube packaging	R	Tape and reel packaging (Not available for 7 position switch)																								
Code	Spec.																																	
Blank	Anti-static tube packaging																																	
R	Tape and reel packaging (Not available for 7 position switch)																																	

Notes: Contact CTS for other common features not listed.

Electrical Specifications

Parameter	Conditions & Remarks	Min	Max	Unit
Circuit	SPST	2	10	positions
Contact Resistance	Initial At end of life		50 100	milliohms
Insulation Resistance	Between insulated terminals	1000		megohms
Dielectric Strength	500 VAC between adjacent switches		1	minute
Actuation Life	50mA @ 24 VDC		7,000	cycles
Switch Capacitance	Between adjacent closed switches		5.0	pF
Nonswitching Rating			100 or 50	mA or VDC

Mechanical and Environmental

Soldering	Maximum reflow temperature, 250°C for 30 seconds
MSL	Level 1
RoHS	Lead-Free. Fully compliant to RoHS Directive 2011/65/EU
Shock	Per MIL-STD-202F, method 213B, condition A (50G's) with no contact inconsistencies greater than 1 microsecond
Vibration	Per MIL-STD-202F, method 204D, condition B (.06" or 15G's between 10 HZ to 2K HZ) with no contact inconsistencies greater than 1 microsecond
Seal	Bottom seal standard
Marking	Special side or top marking available-consult CTS
Packaging:	Standard anti-static tube packaging, optional tape & reel packaging
Operating Temperature Range	-40°C to +85°C
Storage Temperature Range	-40°C to +85°C

Soldering Profile

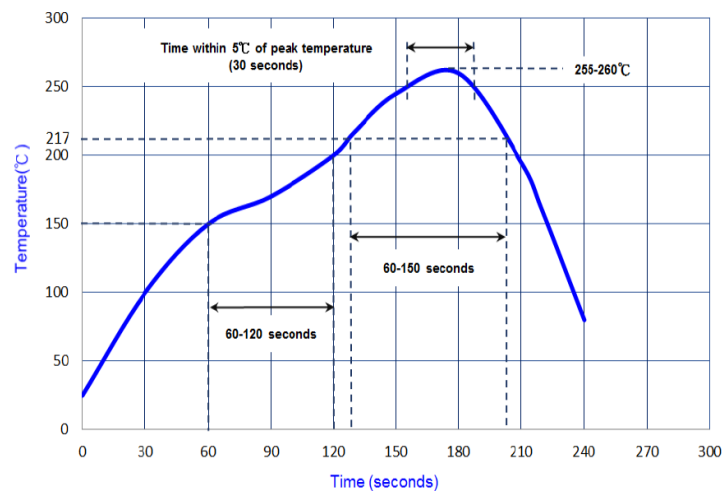

Mechanical Specifications

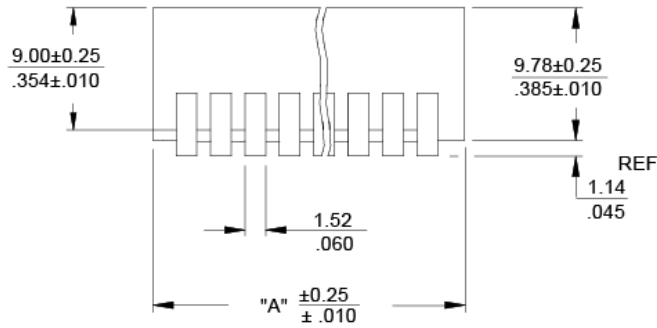

Surface Mount Pad Layouts

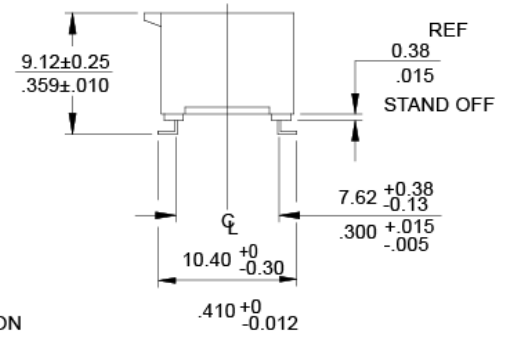
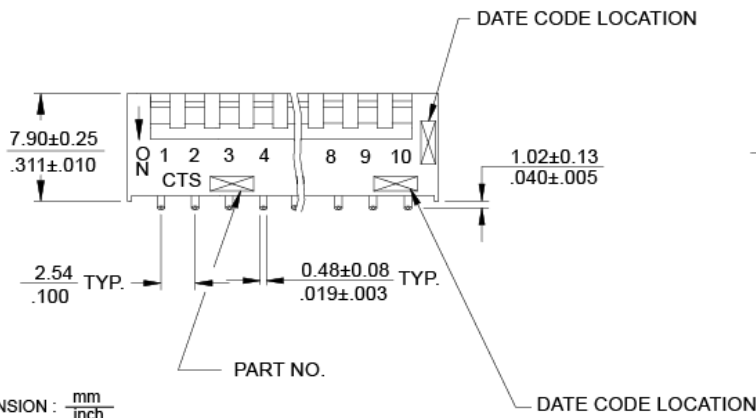
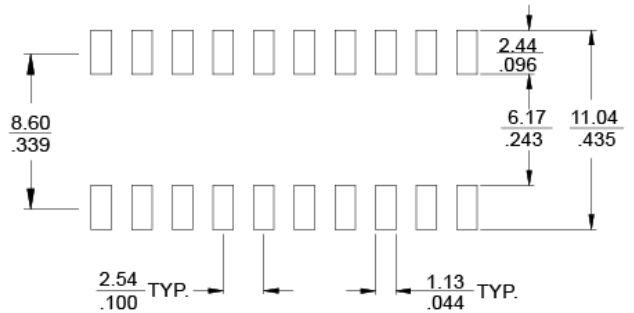

DIMENSION : $\frac{\text{mm}}{\text{inch}}$
 STANDARD TOLERANCE :
 .X (1 PLACE) : $\frac{\pm 0.3}{\pm 0.012}$.XX(2 PLACE) : $\frac{\pm 0.13}{\pm 0.005}$

"A" Overall Dimensions	No. of Switch Positions	Part Number
7.26 / .286	2	193-2MS
9.80 / .386	3	193-3MS
12.34 / .486	4	193-4MS
14.88 / .586	5	193-5MS
17.42 / .686	6	193-6MS
19.96 / .786	7	193-7MS
22.50 / .886	8	193-8MS
25.04 / .986	9	193-9MS
27.58 / 1.086	10	193-10MS

Packing: Tape and Reel

Unit: mm

SW Section	Fig	Bo	W	F	S
2	I	7.15	24.0	11.50	-
3	I	9.69	24.0	11.50	-
4	I	12.23	24.0	11.50	-
5	II	14.81	32.0	14.20	28.4
6	II	17.35	32.0	14.20	28.4
8	II	22.40	44.0	20.20	40.4
9	II	24.94	44.0	20.20	40.4
10	II	27.48	44.0	20.20	40.4
12	II	32.56	44.0	20.20	40.4

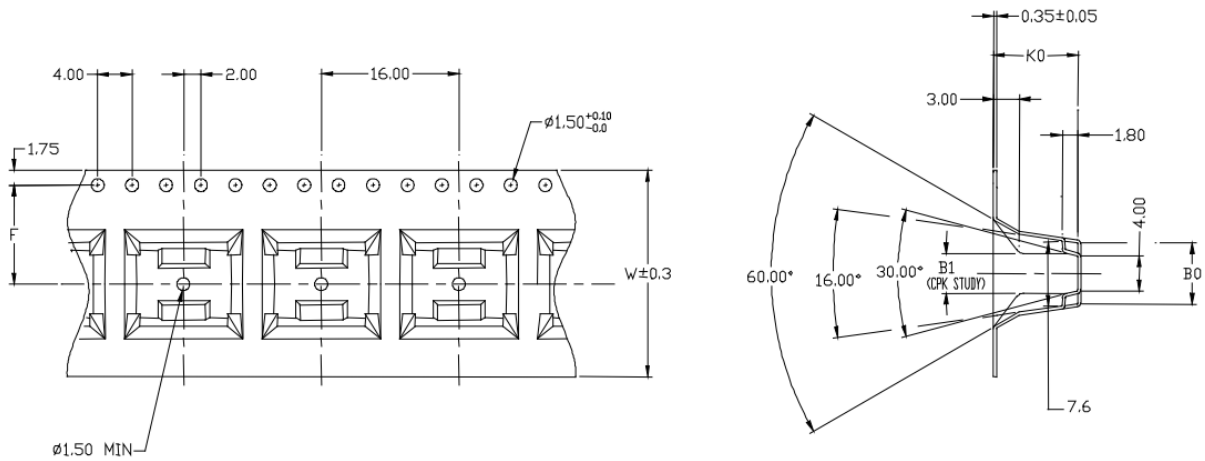

FIG I

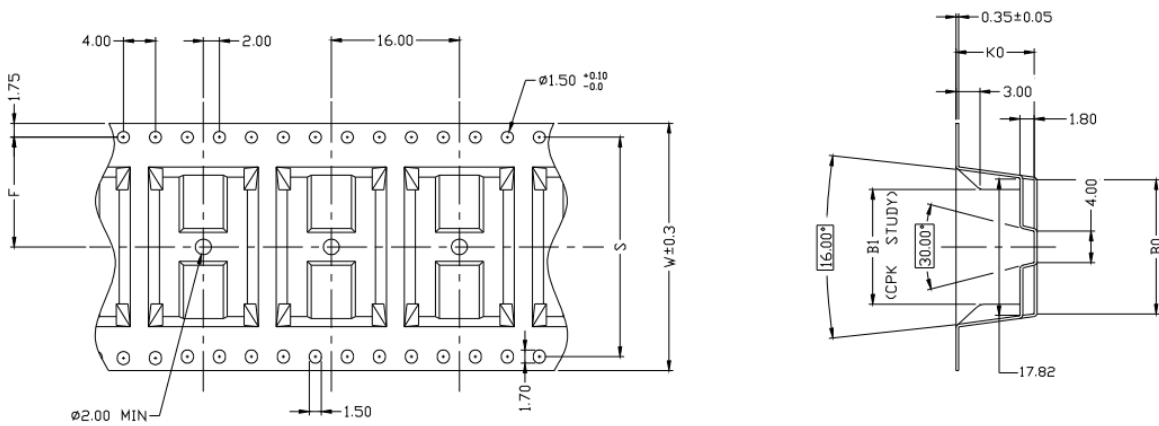

FIG II

SPECIFIED REEL PARTS DIMENSIONS:

Unit: mm

SW Section	W1	W2	W3
2~4	24.4	30.4 MAX.	23.9 MIN./27.4 MAX.
5~6	32.4	38.4 MAX.	31.9 MIN./35.4 MAX.
8~12	44.4	50.4 MAX.	43.9 MIN./47.4 MAX.

(SEE PICTURE FIG)

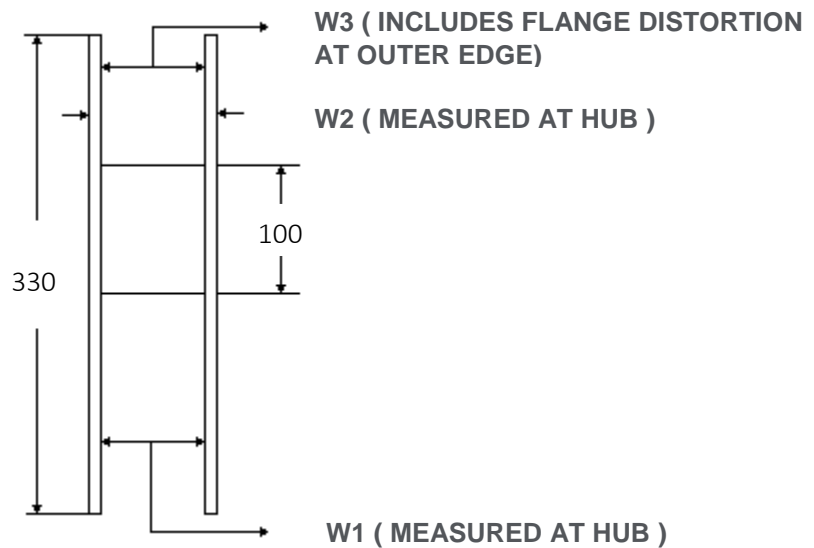

1. TAPE SPROCKET HOLE PITCH : 4.0 ± 0.1 MM
2. ALL SMT ASSEMBLING MACHINES WILL PICK-UP THE COMPONENT FROM THE POINT, WHICH IS LOCATED IN THE CENTRE OF TWO ADJACENT SPROCKET HOLES IN FEEDING DIRECTION. THIS MUST BE TAKE INTO ACCOUNT WHEN DESIGNING THE LOCATION OF THE COMPONENT IN T&R POCKET.
3. RECOMMENDED PART ORIENTATION IN TAPE & REEL POCKET. ORIENT SWITCH TERMINAL #1 TO THE SIDE OF ROUND SPROCKET HOLES, SEE PICTURE BELOW.

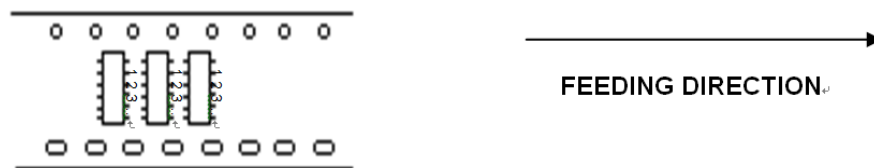

LENGTH OF TAPE

5. THERE SHALL BE A LEADER OF 390mm MINIMUM WHICH IS SEALED ONTO EMPTY CARRIER TAPE, SEE PICTURE BELOW.

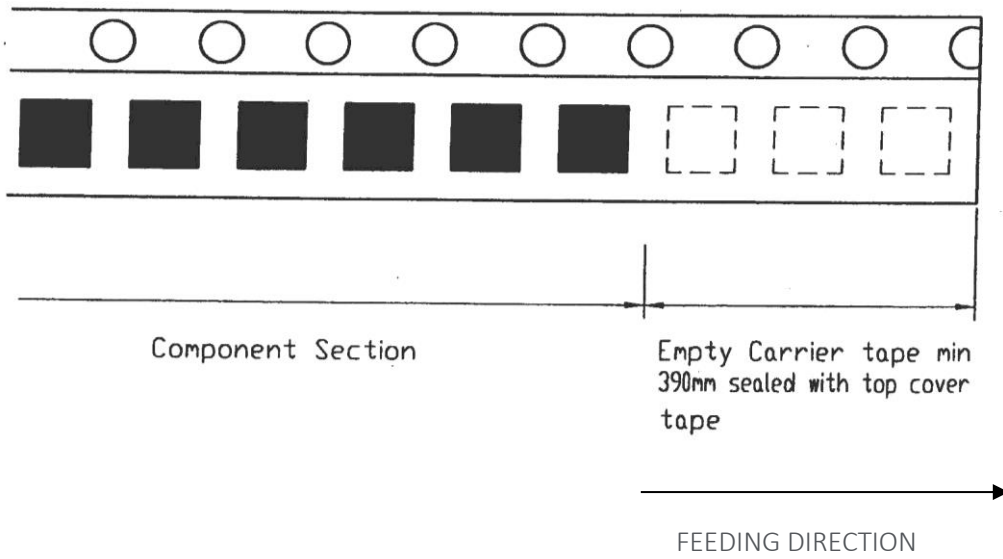
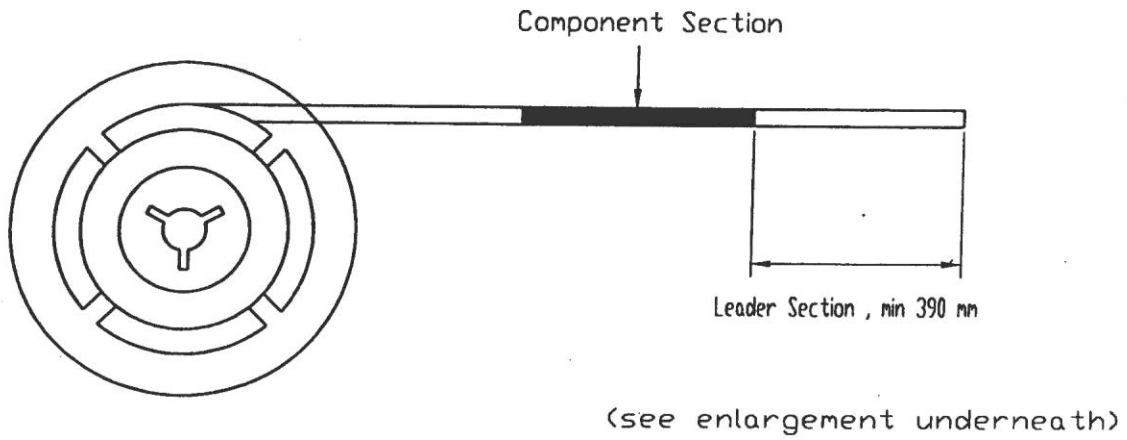

Mouser Electronics

Authorized Distributor

Click to View Pricing, Inventory, Delivery & Lifecycle Information:

CTS:

[193-10MS](#) [193-5MS](#) [193-6MS](#) [193-7MS](#) [193-8MS](#) [193-9MS](#) [193-2MSR](#) [193-4MSR](#) [193-6MSR](#) [193-8MSR](#) [193-12MS](#) [193-2MS](#) [193-3MS](#) [193-4MS](#) [193-6MSN](#) [193-7MSN](#) [193-4MSN](#) [193-3MSR](#) [193-5MSR](#) [193-2MSRN](#) [193-3MSN](#) [193-4MSRN](#) [193-8MSRN](#) [193-6MSRN](#) [193-5MSRN](#) [193-10MSRN](#) [193-2MSN](#) [193-5MSN](#) [193-3MSRN](#) [193-9MSN](#) [193-10MSR](#) [193-10MSN](#)