

# ProASIC3 nano Flash FPGAs



## Features and Benefits

### Wide Range of Features

- 10 k to 250 k System Gates
- Up to 36 kbits of True Dual-Port SRAM
- Up to 71 User I/Os

### Reprogrammable Flash Technology

- 130-nm, 7-Layer Metal (6 Copper), Flash-Based CMOS Process
- Live at Power-Up (LAPU) Level 0 Support
- Single-Chip Solution
- Retains Programmed Design when Powered Off

### High Performance

- 350 MHz System Performance

### In-System Programming (ISP) and Security

- Secure ISP Using On-Chip 128-Bit Advanced Encryption Standard (AES) Decryption via JTAG (IEEE 1532-compliant)<sup>†</sup>
- FlashLock<sup>®</sup> to Secure FPGA Contents

### Low Power

- Low Power ProASIC<sup>®</sup>3 nano Products
- 1.5 V Core Voltage for Low Power
- Support for 1.5 V-Only Systems
- Low-Impedance Flash Switches

### High-Performance Routing Hierarchy

- Segmented, Hierarchical Routing and Clock Structure

### Advanced I/Os

- 1.5 V, 1.8 V, 2.5 V, and 3.3 V Mixed-Voltage Operation
- Bank-Selectable I/O Voltages—up to 4 Banks per Chip
- Single-Ended I/O Standards: LVTTTL, LVCMOS 3.3 V / 2.5 V / 1.8 V / 1.5 V
- Wide Range Power Supply Voltage Support per JESD8-B, Allowing I/Os to Operate from 2.7 V to 3.6 V
- I/O Registers on Input, Output, and Enable Paths
- Selectable Schmitt Trigger Inputs
- Hot-Swappable and Cold-Sparing I/Os
- Programmable Output Slew Rate<sup>†</sup> and Drive Strength
- Weak Pull-Up/-Down
- IEEE 1149.1 (JTAG) Boundary Scan Test
- Pin-Compatible Packages across the ProASIC3 Family

### Clock Conditioning Circuit (CCC) and PLL<sup>†</sup>

- Up to Six CCC Blocks, One with an Integrated PLL
- Configurable Phase Shift, Multiply/Divide, Delay Capabilities and External Feedback
- Wide Input Frequency Range (1.5 MHz to 350 MHz)

### Embedded Memory

- 1 kbit of FlashROM User Nonvolatile Memory
- SRAMs and FIFOs with Variable-Aspect-Ratio 4,608-Bit RAM Blocks (x1, x2, x4, x9, and x18 organizations)<sup>†</sup>
- True Dual-Port SRAM (except x18 organization)<sup>†</sup>

### Enhanced Commercial Temperature Range

- -20°C to +70°C

Table 1 • ProASIC3 nano Devices

ProASIC3 nano Devices	A3PN010	A3PN015	A3PN020		A3PN060	A3PN125	A3PN250
ProASIC3 nano-Z Devices				A3PN030Z <sup>1</sup>	A3PN060Z	A3PN125Z	A3N250Z
System Gates	10K	15K	20K	30K	60K	125K	250K
Typical Equivalent Macrocells	86	128	172	256	512	1,024	2,048
VersaTiles (D-flip-flops)	260	384	520	768	1,536	3,072	6,144
RAM kbits (1,024 bits) <sup>2</sup>	–	–	–	–	18	36	36
4,608-Bit Blocks <sup>2</sup>	–	–	–	–	4	8	8
FlashROM Bits	1 k	1 k	1 k	1 k	1 k	1 k	1 k
Secure (AES) ISP <sup>2</sup>	–	–	–	–	Yes	Yes	Yes
Integrated PLL in CCCs <sup>2</sup>	–	–	–	–	1	1	1
VersaNet Globals	4	4	4	6	18	18	18
I/O Banks	2	3	3	2	2	2	4
Maximum User I/Os (packaged device)	34	49	49	77	71	71	68
Maximum User I/Os (Known Good Die)	34	–	52	83	71	71	68
Package Pins							
QFN	QN48	QN68	QN68	QN48, QN68	VQ100	VQ100	VQ100
VQFP				VQ100			

Notes:

1. A3PN030 is available in the Z feature grade only.
2. A3PN030 and smaller devices do not support this feature.
3. For higher densities and support of additional features, refer to the ProASIC3 and ProASIC3E handbooks.

<sup>†</sup> A3PN030 and smaller devices do not support this feature.

## I/Os Per Package

ProASIC3 nano Devices	A3PN010	A3PN015	A3PN020		A3PN060	A3PN125	A3PN250
ProASIC3 nano-Z Devices				A3PN030Z <sup>1</sup>	A3PN060	A3PN125Z	A3PN250Z
Known Good Die	34	–	52	83	71	71	68
QN48	34			34			
QN68		49	49	49			
VQ100				77	71	71	68

### Notes:

1. A3PN030 is available in the Z feature grade only.
2. When considering migrating your design to a lower- or higher-density device, refer to the [ProASIC3 Handbook](#) to ensure compliance with design and board migration requirements.
3. "G" indicates RoHS-compliant packages. Refer to "[ProASIC3 nano Ordering Information](#)" on page III for the location of the "G" in the part number. For nano devices, the VQ100 package is offered in both leaded and RoHS-compliant versions. All other packages are RoHS-compliant only.

Table 2 • ProASIC3 nano FPGAs Package Sizes Dimensions

Packages	QN48	QN68	VQ100
Length x Width (mm\mm)	6 x 6	8 x 8	14 x 14
Nominal Area (mm <sup>2</sup> )	36	64	196
Pitch (mm)	0.4	0.4	0.5
Height (mm)	0.90	0.90	1.20

## ProASIC3 nano Device Status

ProASIC3 nano Devices	Status	ProASIC3 nano-Z Devices	Status
A3PN010	Production		
A3PN015	Production		
A3PN020	Production		
		A3PN030Z	Production
A3PN060	Advance	A3PN060Z	Advance
A3PN125	Advance	A3PN125Z	Advance
A3PN250	Production	A3PN250Z	Production

## ProASIC3 nano Ordering Information

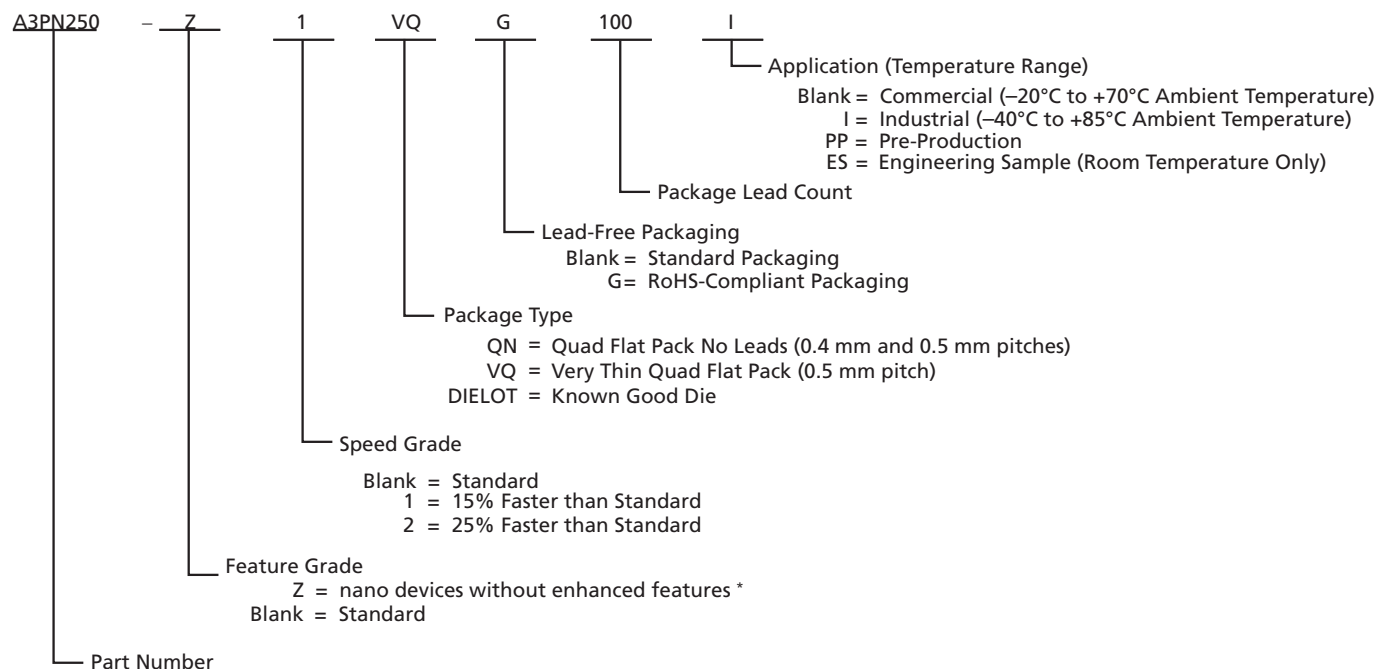

### ProASIC3 nano Devices

A3PN010	= 10,000 System Gates
A3PN015	= 15,000 System Gates
A3PN020	= 20,000 System Gates
A3PN030	= 30,000 System Gates
A3PN060	= 60,000 System Gates
A3PN125	= 125,000 System Gates
A3PN250	= 250,000 System Gates

**Note:** \*For the A3PN060, A3PN125, and A3PN250, the Z feature grade does not support the enhanced nano features of Schmitt trigger input, cold-sparing, and hot-swap I/O capability. The A3PN030 Z feature grade does not support Schmitt trigger input. For the VQ100, CS81, UC81, QN68, and QN48 packages, the Z feature grade and the N part number are not marked on the device.

## Device Marking

Actel normally topside marks the full ordering part number on each device. There are some exceptions to this, such as some of the Z feature grade nano devices, the V2 designator for IGLOO devices, and packages where space is physically limited. Packages that have limited characters available are UC36, UC81, CS81, QN48, QN68, and QFN132. On these specific packages, a subset of the device marking will be used that includes the required legal information and as much of the part number as allowed by character limitation of the device. In this case, devices will have a truncated device marking and may exclude the applications markings, such as the I designator for Industrial Devices or the ES designator for Engineering Samples.

Figure 1 shows an example of device marking based on the AGL030V5-UCG81. The actual mark will vary by the device/package combination ordered.

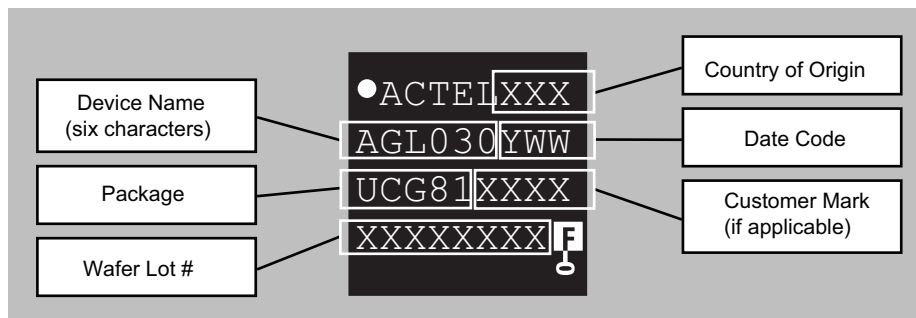

Figure 1 • Example of Device Marking for Small Form Factor Packages

## ProASIC3 nano Product Available in the Z Feature Grade

Devices	A3PN030	A3PN060	A3PN125	A3PN250
Packages	QN48	–	–	–
	QN68	–	–	–
	VQ100	VQ100	VQ100	VQ100

## Temperature Grade Offerings

ProASIC3 nano Devices	A3PN010	A3PN015	A3PN020		A3PN060	A3PN125	A3PN250
ProASIC3 nano-Z Devices				A3PN030Z <sup>1</sup>	A3PN060Z	A3PN125Z	A3PN250Z
QN48	C, I	–	–	C, I	–	–	–
QN68	–	C, I	C, I	C, I	–	–	–
VQ100	–	–	–	C, I	C, I	C, I	C, I

**Notes:**

1. A3PN030 is available in the Z feature grade only.
2. C = Commercial temperature range: –20°C to 70°C ambient temperature
3. I = Industrial temperature range: –40°C to 85°C ambient temperature

## Speed Grade and Temperature Grade Matrix

Temperature Grade	Std.
C <sup>1</sup>	✓
I <sup>2</sup>	✓

**Notes:**

1. C = Commercial temperature range: –20°C to 70°C ambient temperature.
2. I = Industrial temperature range: –40°C to 85°C ambient temperature.

Contact your local Actel representative for device availability: <http://www.actel.com/contact/default.aspx>.

---

# Table of Contents

---

## ProASIC3 nano Device Overview

General Description .....	1-1
---------------------------	-----

## ProASIC3 nano DC and Switching Characteristics

General Specifications .....	2-1
Calculating Power Dissipation .....	2-6
User I/O Characteristics .....	2-12
VersaTile Characteristics .....	2-49
Global Resource Characteristics .....	2-53
Clock Conditioning Circuits .....	2-57
Embedded SRAM and FIFO Characteristics .....	2-59
Embedded FlashROM Characteristics .....	2-69
JTAG 1532 Characteristics .....	2-70
Actel Safety Critical, Life Support, and High-Reliability Applications Policy .....	2-70

## Package Pin Assignments

48-Pin QFN .....	3-1
68-Pin QFN .....	3-4
100-Pin VQFP .....	3-8

## Datasheet Information

List of Changes .....	4-1
Datasheet Categories .....	4-4
Actel Safety Critical, Life Support, and High-Reliability Applications Policy .....	4-4



---

# 1 – ProASIC3 nano Device Overview

---

## General Description

ProASIC3, the third-generation family of Actel flash FPGAs, offers performance, density, and features beyond those of the ProASIC<sup>PLUS</sup>® family. Nonvolatile flash technology gives ProASIC3 nano devices the advantage of being a secure, low power, single-chip solution that is live at power-up (LAPU). ProASIC3 nano devices are reprogrammable and offer time-to-market benefits at an ASIC-level unit cost. These features enable designers to create high-density systems using existing ASIC or FPGA design flows and tools.

ProASIC3 nano devices offer 1 kbit of on-chip, reprogrammable, nonvolatile FlashROM storage as well as clock conditioning circuitry based on an integrated phase-locked loop (PLL). A3PN030 and smaller devices do not have PLL or RAM support. ProASIC3 nano devices have up to 250,000 system gates, supported with up to 36 kbits of true dual-port SRAM and up to 71 user I/Os.

ProASIC3 nano devices increase the breadth of the ProASIC3 product line by adding new features and packages for greater customer value in high volume consumer, portable, and battery-backed markets. Added features include smaller footprint packages designed with two-layer PCBs in mind, low power, hot-swap capability, and Schmitt trigger for greater flexibility in low-cost and power-sensitive applications.

## Flash Advantages

### ***Reduced Cost of Ownership***

Advantages to the designer extend beyond low unit cost, performance, and ease of use. Unlike SRAM-based FPGAs, flash-based ProASIC3 nano devices allow all functionality to be live at power-up; no external boot PROM is required. On-board security mechanisms prevent access to all the programming information and enable secure remote updates of the FPGA logic. Designers can perform secure remote in-system reprogramming to support future design iterations and field upgrades with confidence that valuable intellectual property (IP) cannot be compromised or copied. Secure ISP can be performed using the industry-standard AES algorithm. The ProASIC3 nano device architecture mitigates the need for ASIC migration at higher user volumes. This makes the ProASIC3 nano device a cost-effective ASIC replacement solution, especially for applications in the consumer, networking/communications, computing, and avionics markets.

With a variety of devices under \$1, Actel ProASIC3 nano FPGAs enable cost-effective implementation of programmable logic and quick time to market.

### ***Security***

Nonvolatile, flash-based ProASIC3 nano devices do not require a boot PROM, so there is no vulnerable external bitstream that can be easily copied. ProASIC3 nano devices incorporate FlashLock, which provides a unique combination of reprogrammability and design security without external overhead, advantages that only an FPGA with nonvolatile flash programming can offer.

ProASIC3 nano devices utilize a 128-bit flash-based lock and a separate AES key to secure programmed intellectual property and configuration data. In addition, all FlashROM data in ProASIC3 nano devices can be encrypted prior to loading, using the industry-leading AES-128 (FIPS192) bit block cipher encryption standard. The AES standard was adopted by the National Institute of Standards and Technology (NIST) in 2000 and replaces the 1977 DES standard. ProASIC3 nano devices have a built-in AES decryption engine and a flash-based AES key that make them the most comprehensive programmable logic device security solution available today. ProASIC3 nano devices with AES-based security allow for secure, remote field updates over public networks such as the Internet, and ensure that valuable IP remains out of the hands of system overbuilders, system cloners, and IP thieves. The contents of a programmed ProASIC3 nano device cannot be read back, although secure design verification is possible.

Security, built into the FPGA fabric, is an inherent component of ProASIC3 nano devices. The flash cells are located beneath seven metal layers, and many device design and layout techniques have been used

to make invasive attacks extremely difficult. ProASIC3 nano devices, with FlashLock and AES security, are unique in being highly resistant to both invasive and noninvasive attacks. Your valuable IP is protected and secure, making remote ISP possible. A ProASIC3 nano device provides the most impenetrable security for programmable logic designs.

### **Single Chip**

Flash-based FPGAs store their configuration information in on-chip flash cells. Once programmed, the configuration data is an inherent part of the FPGA structure, and no external configuration data needs to be loaded at system power-up (unlike SRAM-based FPGAs). Therefore, flash-based ProASIC3 nano FPGAs do not require system configuration components such as EEPROMs or microcontrollers to load device configuration data. This reduces bill-of-materials costs and PCB area, and increases security and system reliability.

### **Live at Power-Up**

Actel flash-based ProASIC3 nano devices support Level 0 of the LAPU classification standard. This feature helps in system component initialization, execution of critical tasks before the processor wakes up, setup and configuration of memory blocks, clock generation, and bus activity management. The LAPU feature of flash-based ProASIC3 nano devices greatly simplifies total system design and reduces total system cost, often eliminating the need for CPLDs and clock generation PLLs that are used for these purposes in a system. In addition, glitches and brownouts in system power will not corrupt the ProASIC3 nano device's flash configuration, and unlike SRAM-based FPGAs, the device will not have to be reloaded when system power is restored. This enables the reduction or complete removal of the configuration PROM, expensive voltage monitor, brownout detection, and clock generator devices from the PCB design. Flash-based ProASIC3 nano devices simplify total system design and reduce cost and design risk while increasing system reliability and improving system initialization time.

### **Firm Errors**

Firm errors occur most commonly when high-energy neutrons, generated in the upper atmosphere, strike a configuration cell of an SRAM FPGA. The energy of the collision can change the state of the configuration cell and thus change the logic, routing, or I/O behavior in an unpredictable way. These errors are impossible to prevent in SRAM FPGAs. The consequence of this type of error can be a complete system failure. Firm errors do not exist in the configuration memory of ProASIC3 nano flash-based FPGAs. Once it is programmed, the flash cell configuration element of ProASIC3 nano FPGAs cannot be altered by high-energy neutrons and is therefore immune to them. Recoverable (or soft) errors occur in the user data SRAM of all FPGA devices. These can easily be mitigated by using error detection and correction (EDAC) circuitry built into the FPGA fabric.

### **Low Power**

Flash-based ProASIC3 nano devices exhibit power characteristics similar to an ASIC, making them an ideal choice for power-sensitive applications. ProASIC3 nano devices have only a very limited power-on current surge and no high-current transition period, both of which occur on many FPGAs.

ProASIC3 nano devices also have low dynamic power consumption to further maximize power savings.

## **Advanced Flash Technology**

ProASIC3 nano devices offer many benefits, including nonvolatility and reprogrammability through an advanced flash-based, 130-nm LVCMOS process with seven layers of metal. Standard CMOS design techniques are used to implement logic and control functions. The combination of fine granularity, enhanced flexible routing resources, and abundant flash switches allows for very high logic utilization without compromising device routability or performance. Logic functions within the device are interconnected through a four-level routing hierarchy.

## **Advanced Architecture**

The proprietary ProASIC3 nano architecture provides granularity comparable to standard-cell ASICs. The ProASIC3 nano device consists of five distinct and programmable architectural features ([Figure 1-3](#) to [Figure 1-4](#) on page 1-4):

- FPGA VersaTiles

- Dedicated FlashROM
- Dedicated SRAM/FIFO memory
- Extensive CCCs and PLLs
- Advanced I/O structure

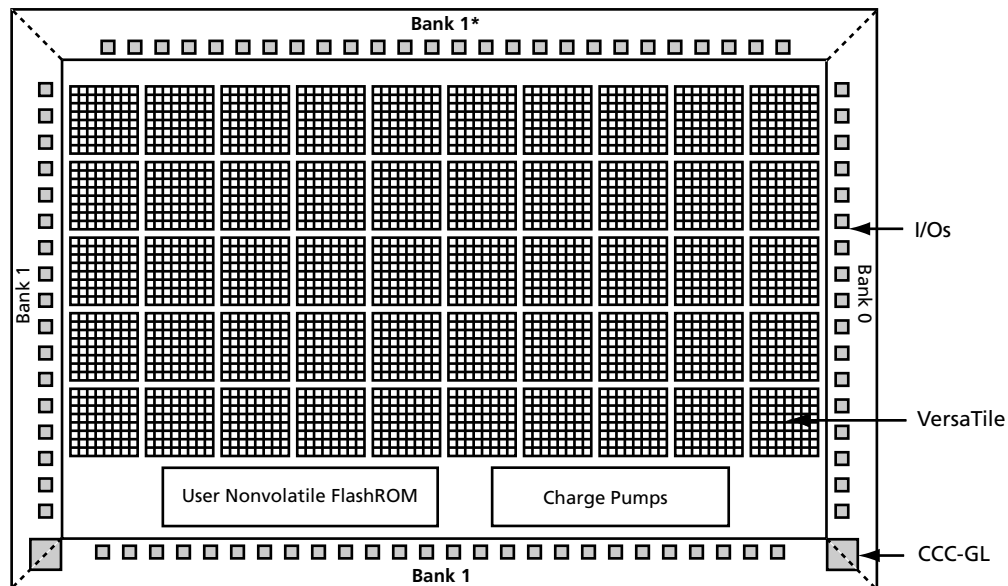

Note: \*Bank 0 for the A3PN030 device

**Figure 1-1 • ProASIC3 Device Architecture Overview with Two I/O Banks and No RAM (A3PN010 and A3PN030)**

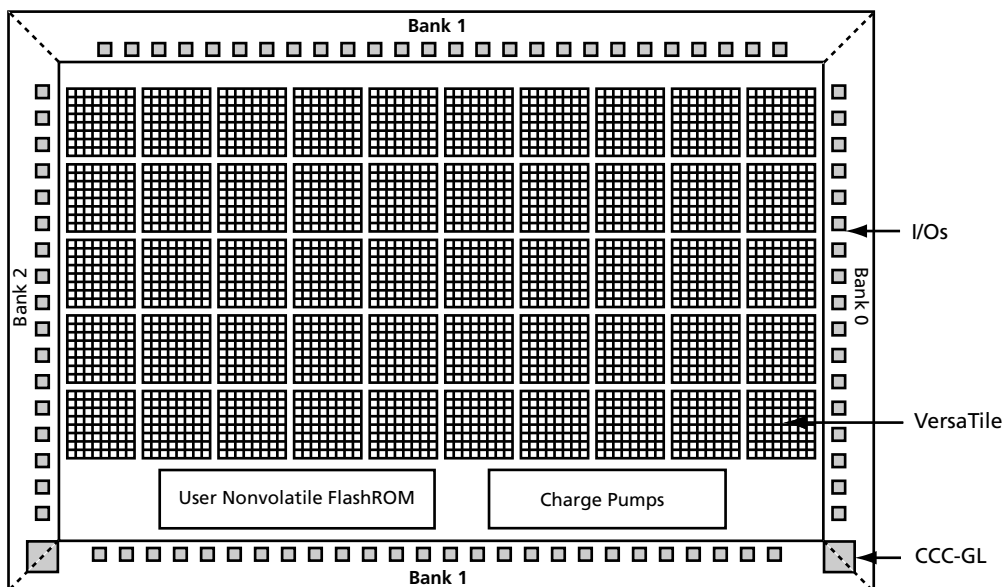

**Figure 1-2 • ProASIC3 nano Architecture Overview with Three I/O Banks and No RAM (A3PN015 and A3PN020)**

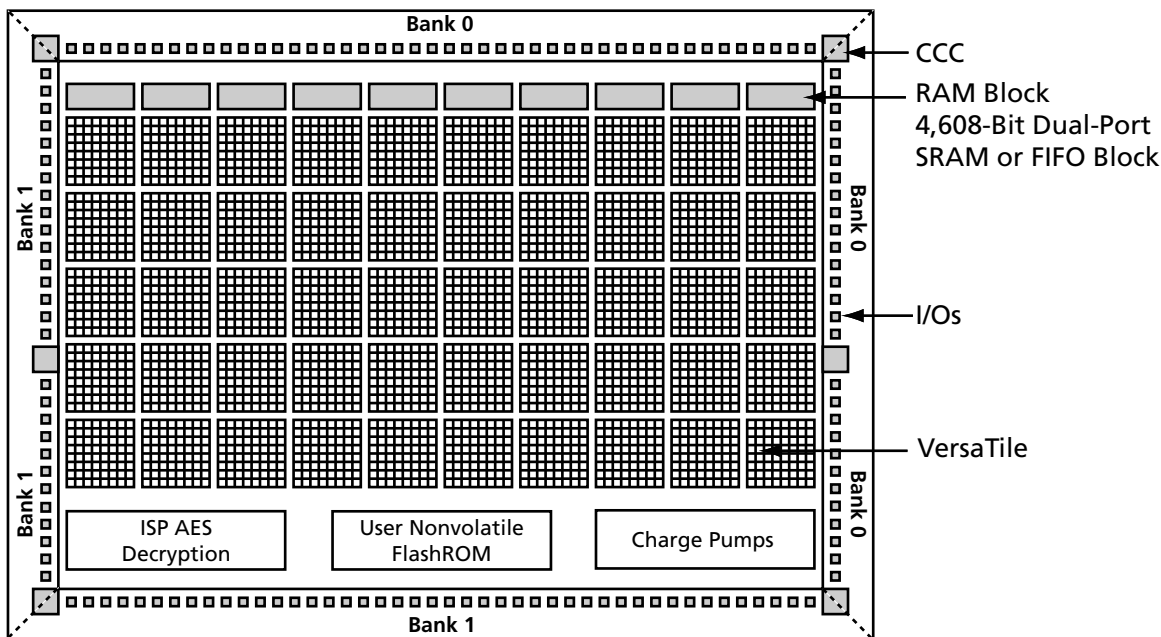

Figure 1-3 • ProASIC3 nano Device Architecture Overview with Two I/O Banks (A3PN060 and A3PN125)

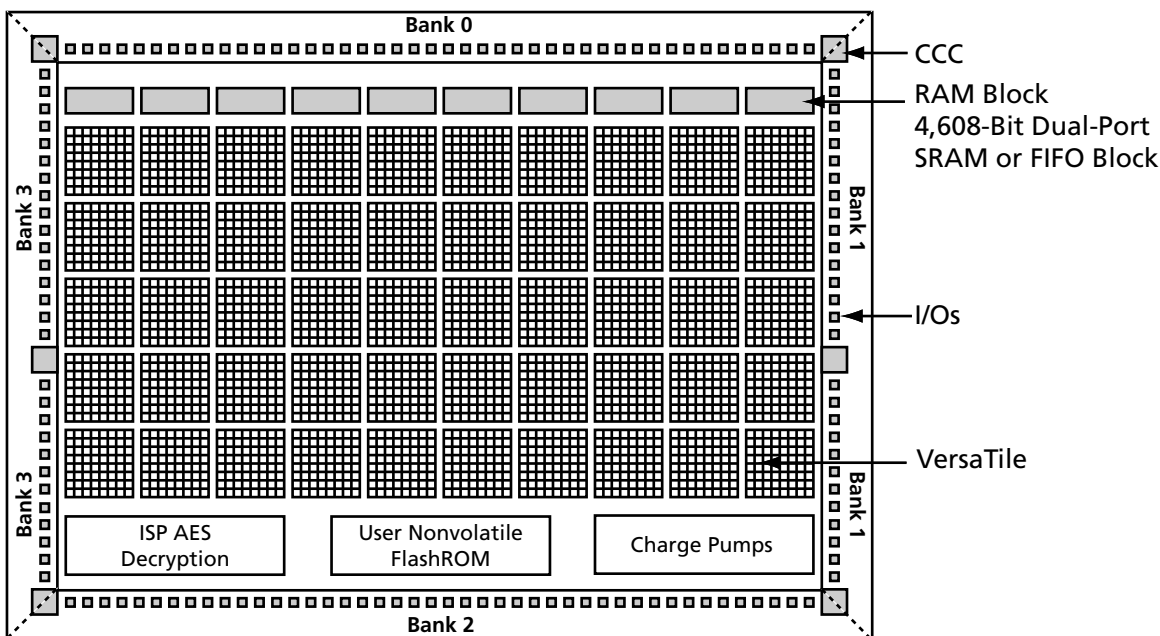

Figure 1-4 • ProASIC3 nano Device Architecture Overview with Four I/O Banks (A3PN250)

The FPGA core consists of a sea of VersaTiles. Each VersaTile can be configured as a three-input logic function, a D-flip-flop (with or without enable), or a latch by programming the appropriate flash switch interconnections. The versatility of the ProASIC3 nano core tile as either a three-input lookup table (LUT) equivalent or as a D-flip-flop/latch with enable allows for efficient use of the FPGA fabric. The VersaTile

capability is unique to the Actel ProASIC3 family of third-generation architecture flash FPGAs. VersaTiles are connected with any of the four levels of routing hierarchy. Flash switches are distributed throughout the device to provide nonvolatile, reconfigurable interconnect programming. Maximum core utilization is possible for virtually any design.

In addition, extensive on-chip programming circuitry allows for rapid, single-voltage (3.3 V) programming of ProASIC3 nano devices via an IEEE 1532 JTAG interface.

### VersaTiles

The ProASIC3 nano core consists of VersaTiles, which have been enhanced beyond the ProASIC<sup>PLUS</sup>® core tiles. The ProASIC3 nano VersaTile supports the following:

- All 3-input logic functions—LUT-3 equivalent
- Latch with clear or set
- D-flip-flop with clear or set
- Enable D-flip-flop with clear or set

Refer to [Figure 1-5](#) for VersaTile configurations.

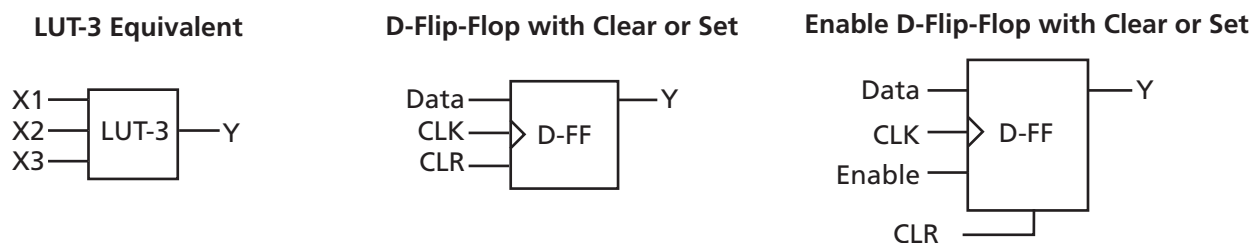

**Figure 1-5 • VersaTile Configurations**

### User Nonvolatile FlashROM

Actel ProASIC3 nano devices have 1 kbit of on-chip, user-accessible, nonvolatile FlashROM. The FlashROM can be used in diverse system applications:

- Internet protocol addressing (wireless or fixed)
- System calibration settings
- Device serialization and/or inventory control
- Subscription-based business models (for example, set-top boxes)
- Secure key storage for secure communications algorithms
- Asset management/tracking
- Date stamping
- Version management

The FlashROM is written using the standard ProASIC3 nano IEEE 1532 JTAG programming interface. The core can be individually programmed (erased and written), and on-chip AES decryption can be used selectively to securely load data over public networks (except in the A3PN030 and smaller devices), as in security keys stored in the FlashROM for a user design.

The FlashROM can be programmed via the JTAG programming interface, and its contents can be read back either through the JTAG programming interface or via direct FPGA core addressing. Note that the FlashROM can only be programmed from the JTAG interface and cannot be programmed from the internal logic array.

The FlashROM is programmed as 8 banks of 128 bits; however, reading is performed on a byte-by-byte basis using a synchronous interface. A 7-bit address from the FPGA core defines which of the 8 banks and which of the 16 bytes within that bank are being read. The three most significant bits (MSBs) of the FlashROM address determine the bank, and the four least significant bits (LSBs) of the FlashROM address define the byte.

The Actel ProASIC3 nano development software solutions, Libero® Integrated Design Environment (IDE) and Designer, have extensive support for the FlashROM. One such feature is auto-generation of sequential programming files for applications requiring a unique serial number in each part. Another feature enables the inclusion of static data for system version control. Data for the FlashROM can be generated quickly and easily using Actel Libero IDE and Designer software tools. Comprehensive programming file support is also included to allow for easy programming of large numbers of parts with differing FlashROM contents.

### **SRAM and FIFO**

ProASIC3 nano devices (except the A3PN030 and smaller devices) have embedded SRAM blocks along their north and south sides. Each variable-aspect-ratio SRAM block is 4,608 bits in size. Available memory configurations are 256x18, 512x9, 1kx4, 2kx2, and 4kx1 bits. The individual blocks have independent read and write ports that can be configured with different bit widths on each port. For example, data can be sent through a 4-bit port and read as a single bitstream. The embedded SRAM blocks can be initialized via the device JTAG port (ROM emulation mode) using the UJTAG macro (except in A3PN030 and smaller devices).

In addition, every SRAM block has an embedded FIFO control unit. The control unit allows the SRAM block to be configured as a synchronous FIFO without using additional core VersaTiles. The FIFO width and depth are programmable. The FIFO also features programmable Almost Empty (AEMPTY) and Almost Full (AFULL) flags in addition to the normal Empty and Full flags. The embedded FIFO control unit contains the counters necessary for generation of the read and write address pointers. The embedded SRAM/FIFO blocks can be cascaded to create larger configurations.

### **PLL and CCC**

Higher density ProASIC3 nano devices using either the two I/O bank or four I/O bank architectures provide the designer with very flexible clock conditioning capabilities. A3PN060, A3PN125, and A3PN250 contain six CCCs. One CCC (center west side) has a PLL. The A3PN030 and smaller devices use different CCCs in their architecture. These CCC-GLs contain a global MUX but do not have any PLLs or programmable delays.

For devices using the six CCC block architecture, these six CCC blocks are located at the four corners and the centers of the east and west sides.

All six CCC blocks are usable; the four corner CCCs and the east CCC allow simple clock delay operations as well as clock spine access. The inputs of the six CCC blocks are accessible from the FPGA core or from dedicated connections to the CCC block, which are located near the CCC.

The CCC block has these key features:

- Wide input frequency range ( $f_{IN\_CCC}$ ) = 1.5 MHz to 350 MHz
- Output frequency range ( $f_{OUT\_CCC}$ ) = 0.75 MHz to 350 MHz
- Clock delay adjustment via programmable and fixed delays from -7.56 ns to +11.12 ns
- 2 programmable delay types for clock skew minimization
- Clock frequency synthesis (for PLL only)

Additional CCC specifications:

- Internal phase shift = 0°, 90°, 180°, and 270°. Output phase shift depends on the output divider configuration (for PLL only).
- Output duty cycle = 50% ± 1.5% or better (for PLL only)
- Low output jitter: worst case < 2.5% × clock period peak-to-peak period jitter when single global network used (for PLL only)
- Maximum acquisition time = 300 μs (for PLL only)
- Low power consumption of 5 mW
- Exceptional tolerance to input period jitter—allowable input jitter is up to 1.5 ns (for PLL only)
- Four precise phases; maximum misalignment between adjacent phases of 40 ps × (350 MHz /  $f_{OUT\_CCC}$ ) (for PLL only)

## **Global Clocking**

ProASIC3 nano devices have extensive support for multiple clocking domains. In addition to the CCC and PLL support described above, there is a comprehensive global clock distribution network.

Each VersaTile input and output port has access to nine VersaNets: six chip (main) and three quadrant global networks. The VersaNets can be driven by the CCC or directly accessed from the core via multiplexers (MUXes). The VersaNets can be used to distribute low-skew clock signals or for rapid distribution of high fanout nets.

## **I/Os with Advanced I/O Standards**

ProASIC3 nano FPGAs feature a flexible I/O structure, supporting a range of voltages (1.5 V, 1.8 V, 2.5 V, and 3.3 V).

The I/Os are organized into banks, with two, three, or four banks per device. The configuration of these banks determines the I/O standards supported.

Each I/O module contains several input, output, and enable registers. These registers allow the implementation of various single-data-rate applications for all versions of nano devices and double-data-rate applications for the A3PN060, A3PN125, and A3PN250 devices.

ProASIC3 nano devices support LVTTTL and LVCMOS I/O standards, are hot-swappable, and support cold-sparing and Schmitt trigger.

Hot-swap (also called hot-plug, or hot-insertion) is the operation of hot-insertion or hot-removal of a card in a powered-up system.

Cold-sparing (also called cold-swap) refers to the ability of a device to leave system data undisturbed when the system is powered up, while the component itself is powered down, or when power supplies are floating.

## **Wide Range I/O Support**

Actel nano devices support JEDEC-defined wide range I/O operation. ProASIC3 nano supports the JESD8-B specification, covering both 3 V and 3.3 V supplies, for an effective operating range of 2.7 V to 3.6 V.

Wider I/O range means designers can eliminate power supplies or power conditioning components from the board or move to less costly components with greater tolerances. Wide range eases I/O bank management and provides enhanced protection from system voltage spikes, while providing the flexibility to easily run custom voltage applications.



## 2 – ProASIC3 nano DC and Switching Characteristics

### General Specifications

The Z feature grade does not support the enhanced nano features of Schmitt trigger input, cold-sparing, and hot-swap I/O capability. Refer to the ordering information in the *ProASIC3 nano Product Brief* for more information.

DC and switching characteristics for –F speed grade targets are based only on simulation.

The characteristics provided for the –F speed grade are subject to change after establishing FPGA specifications. Some restrictions might be added and will be reflected in future revisions of this document. The –F speed grade is only supported in the commercial temperature range.

### Operating Conditions

Stresses beyond those listed in [Table 2-1](#) may cause permanent damage to the device.

Exposure to absolute maximum rating conditions for extended periods may affect device reliability. Absolute Maximum Ratings are stress ratings only; functional operation of the device at these or any other conditions beyond those listed under the Recommended Operating Conditions specified in [Table 2-2](#) on [page 2-2](#) is not implied.

**Table 2-1 • Absolute Maximum Ratings**

Symbol	Parameter	Limits	Units
VCC	DC core supply voltage	–0.3 to 1.65	V
VJTAG	JTAG DC voltage	–0.3 to 3.75	V
VPUMP	Programming voltage	–0.3 to 3.75	V
VCCPLL	Analog power supply (PLL)	–0.3 to 1.65	V
VCCI	DC I/O output buffer supply voltage	–0.3 to 3.75	V
VI	I/O input voltage	–0.3 V to 3.6 V	V
T <sub>STG</sub> <sup>1</sup>	Storage temperature	–65 to +150	°C
T <sub>J</sub> <sup>1</sup>	Junction temperature	+125	°C

**Notes:**

1. For flash programming and retention maximum limits, refer to [Table 2-3](#) on [page 2-2](#), and for recommended operating limits, refer to [Table 2-2](#) on [page 2-2](#).
2. The device should be operated within the limits specified by the datasheet. During transitions, the input signal may undershoot or overshoot according to the limits shown in [Table 2-4](#) on [page 2-3](#).

**Table 2-2 • Recommended Operating Conditions** <sup>1, 2</sup>

Symbol	Parameter		Extended Commercial	Industrial	Units
T <sub>A</sub>	Ambient temperature		–20 to +70 <sup>2</sup>	–40 to +85 <sup>2</sup>	°C
T <sub>J</sub>	Junction temperature		–20 to +85	–40 to +100	°C
VCC <sup>3</sup>	1.5 V DC core supply voltage		1.425 to 1.575	1.425 to 1.575	V
VJTAG	JTAG DC voltage		1.4 to 3.6	1.4 to 3.6	V
VPUMP <sup>4</sup>	Programming voltage	Programming Mode	3.15 to 3.45	3.15 to 3.45	V
		Operation <sup>4</sup>	0 to 3.6	0 to 3.6	V
VCCPLL <sup>5</sup>	Analog power supply (PLL)	1.5 V DC core supply voltage <sup>3</sup>	1.425 to 1.575	1.425 to 1.575	V
VCCI and VMV <sup>7</sup>	1.5 V DC supply voltage		1.425 to 1.575	1.425 to 1.575	V
	1.8 V DC supply voltage		1.7 to 1.9	1.7 to 1.9	V
	2.5 V DC supply voltage		2.3 to 2.7	2.3 to 2.7	V
	3.3 V DC supply voltage		3.0 to 3.6	3.0 to 3.6	V
	3.3 V Wide Range supply voltage <sup>6</sup>		2.7 to 3.6	2.7 to 3.6	V

**Notes:**

1. All parameters representing voltages are measured with respect to GND unless otherwise specified.
2. To ensure targeted reliability standards are met across ambient and junction operating temperatures, Actel recommends that the user follow best design practices using Actel's timing and power simulation tools.
3. The ranges given here are for power supplies only. The recommended input voltage ranges specific to each I/O standard are given in [Table 2-14 on page 2-16](#). VMV and VCCI should be at the same voltage within a given I/O bank.
4. V<sub>PUMP</sub> can be left floating during operation (not programming mode).
5. VCCPLL pins should be tied to VCC pins. See the "[Pin Descriptions and Packaging](#)" chapter for further information.
6. 3.3 V Wide Range is compliant to the JESD8-B specification and supports 3.0 V VCCI operation.
7. VMV pins must be connected to the corresponding VCCI pins. See the "[Pin Descriptions and Packaging](#)" chapter for further information.

**Table 2-3 • Flash Programming Limits – Retention, Storage and Operating Temperature** <sup>1</sup>

Product Grade	Programming Cycles	Program Retention (biased/unbiased)	Maximum Storage Temperature T <sub>STG</sub> (°C) <sup>2</sup>	Maximum Operating Junction Temperature T <sub>J</sub> (°C) <sup>2</sup>
Commercial	500	20 years	110	100
Industrial	500	20 years	110	100

**Notes:**

1. This is a stress rating only; functional operation at any condition other than those indicated is not implied.
2. These limits apply for program/data retention only. Refer to [Table 2-1 on page 2-1](#) and [Table 2-2](#) for device operating conditions and absolute limits.

**Table 2-4 • Overshoot and Undershoot Limits <sup>1</sup>**

VCCI and VMV	Average VCCI–GND Overshoot or Undershoot Duration as a Percentage of Clock Cycle <sup>2</sup>	Maximum Overshoot/Undershoot <sup>2</sup>
2.7 V or less	10%	1.4 V
	5%	1.49 V
3 V	10%	1.1 V
	5%	1.19 V
3.3 V	10%	0.79 V
	5%	0.88 V
3.6 V	10%	0.45 V
	5%	0.54 V

**Notes:**

1. Based on reliability requirements at 85°C.
2. The duration is allowed at one out of six clock cycles. If the overshoot/undershoot occurs at one out of two cycles, the maximum overshoot/undershoot has to be reduced by 0.15 V.

## I/O Power-Up and Supply Voltage Thresholds for Power-On Reset (Commercial and Industrial)

Sophisticated power-up management circuitry is designed into every ProASIC<sup>®</sup>3 device. These circuits ensure easy transition from the powered-off state to the powered-up state of the device. The many different supplies can power up in any sequence with minimized current spikes or surges. In addition, the I/O will be in a known state through the power-up sequence. The basic principle is shown in [Figure 2-1 on page 2-4](#).

There are five regions to consider during power-up.

ProASIC3 I/Os are activated only if ALL of the following three conditions are met:

1. VCC and VCCI are above the minimum specified trip points ([Figure 2-1 on page 2-4](#)).
2.  $VCCI > VCC - 0.75 \text{ V}$  (typical)
3. Chip is in the operating mode.

### VCCI Trip Point:

Ramping up:  $0.6 \text{ V} < \text{trip\_point\_up} < 1.2 \text{ V}$

Ramping down:  $0.5 \text{ V} < \text{trip\_point\_down} < 1.1 \text{ V}$

### VCC Trip Point:

Ramping up:  $0.6 \text{ V} < \text{trip\_point\_up} < 1.1 \text{ V}$

Ramping down:  $0.5 \text{ V} < \text{trip\_point\_down} < 1 \text{ V}$

VCC and VCCI ramp-up trip points are about 100 mV higher than ramp-down trip points. This specifically built-in hysteresis prevents undesirable power-up oscillations and current surges. Note the following:

- During programming, I/Os become tristated and weakly pulled up to VCCI.
- JTAG supply, PLL power supplies, and charge pump VPUMP supply have no influence on I/O behavior.

### PLL Behavior at Brownout Condition

Actel recommends using monotonic power supplies or voltage regulators to ensure proper power-up behavior. Power ramp-up should be monotonic at least until VCC and VCCPLLX exceed brownout activation levels. The VCC activation level is specified as 1.1 V worst-case (see [Figure 2-1 on page 2-4](#) for more details).

When PLL power supply voltage and/or VCC levels drop below the VCC brownout levels ( $0.75 \text{ V} \pm 0.25 \text{ V}$ ), the PLL output lock signal goes low and/or the output clock is lost. Refer to the "Power-Up/-Down Behavior of Low Power Flash Devices" chapter of the [ProASIC3 nano Device Family User's Guide](#) for information on clock and lock recovery.

### Internal Power-Up Activation Sequence

1. Core
2. Input buffers
3. Output buffers, after 200 ns delay from input buffer activation

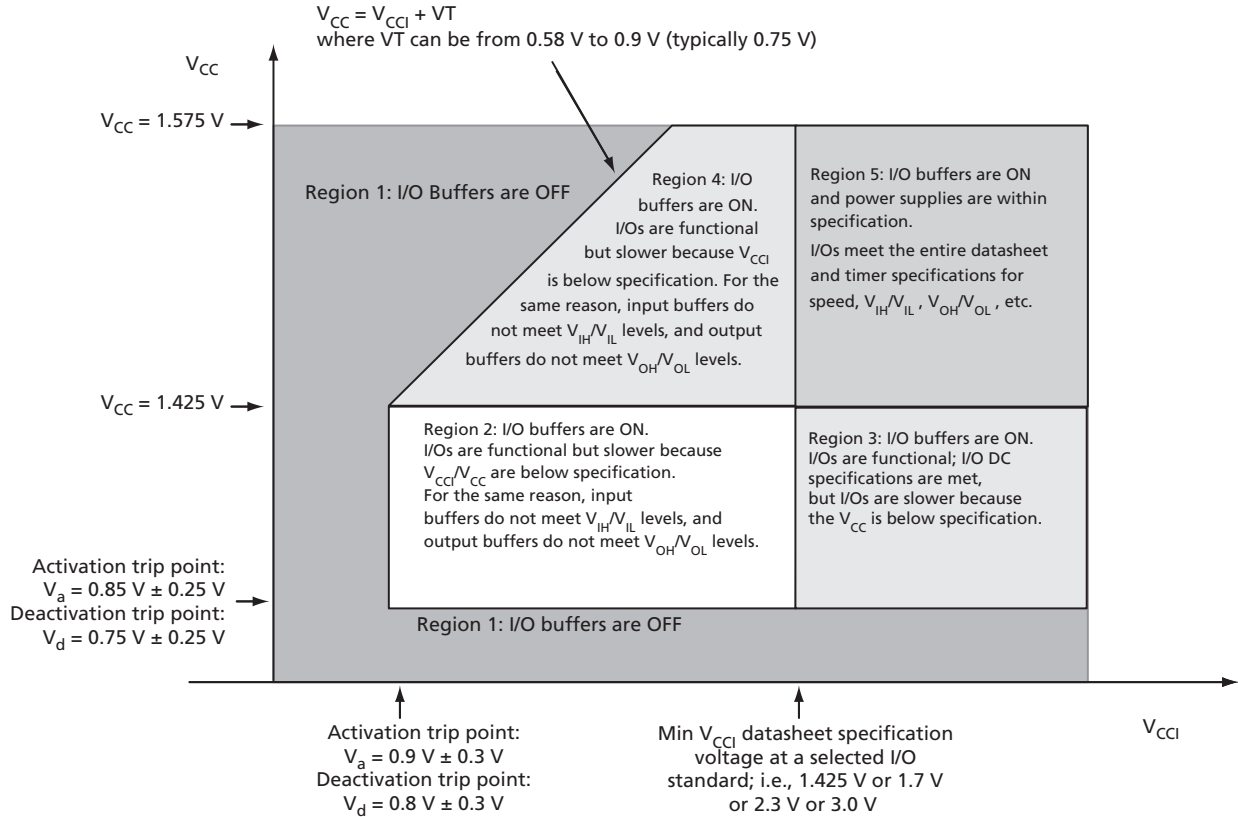

Figure 2-1 • I/O State as a Function of VCCI and VCC Voltage Levels

## Thermal Characteristics

### Introduction

The temperature variable in the Actel Designer software refers to the junction temperature, not the ambient temperature. This is an important distinction because dynamic and static power consumption cause the chip junction to be higher than the ambient temperature.

EQ 1 can be used to calculate junction temperature.

$$T_J = \text{Junction Temperature} = \Delta T + T_A$$

EQ 1

where:

$T_A$  = Ambient Temperature

$\Delta T$  = Temperature gradient between junction (silicon) and ambient  $\Delta T = \theta_{ja} * P$

$\theta_{ja}$  = Junction-to-ambient of the package.  $\theta_{ja}$  numbers are located in Table 2-5.

P = Power dissipation

### Package Thermal Characteristics

The device junction-to-case thermal resistivity is  $\theta_{jc}$  and the junction-to-ambient air thermal resistivity is  $\theta_{ja}$ . The thermal characteristics for  $\theta_{ja}$  are shown for two air flow rates. The absolute maximum junction temperature is 100°C. EQ 2 shows a sample calculation of the absolute maximum power dissipation allowed for a 484-pin FBGA package at commercial temperature and in still air.

$$\text{Maximum Power Allowed} = \frac{\text{Max. junction temp. (}^\circ\text{C)} - \text{Max. ambient temp. (}^\circ\text{C)}}{\theta_{ja} (\text{}^\circ\text{C/W)}} = \frac{100^\circ\text{C} - 70^\circ\text{C}}{20.5^\circ\text{C/W}} = 1.463 \text{ W}$$

EQ 2

**Table 2-5 • Package Thermal Resistivities**

Package Type	Device	Pin Count	$\theta_{jc}$	$\theta_{ja}$			Units
				Still Air	200 ft./min.	500 ft./min.	
Quad Flat No Lead (QFN)	All devices	48	TBD	TBD	TBD	TBD	C/W
		68	TBD	TBD	TBD	TBD	C/W
		100	TBD	TBD	TBD	TBD	C/W
Very Thin Quad Flat Pack (VQFP)	All devices	100	10.0	35.3	29.4	27.1	C/W

### Temperature and Voltage Derating Factors

**Table 2-6 • Temperature and Voltage Derating Factors for Timing Delays**  
(normalized to  $T_J = 70^\circ\text{C}$ ,  $V_{CC} = 1.425 \text{ V}$ )

Array Voltage $V_{CC}$ (V)	Junction Temperature ( $^\circ\text{C}$ )						
	$-40^\circ\text{C}$	$-20^\circ\text{C}$	$0^\circ\text{C}$	$25^\circ\text{C}$	$70^\circ\text{C}$	$85^\circ\text{C}$	$100^\circ\text{C}$
1.425	0.968	0.973	0.979	0.991	1.000	1.006	1.013
1.500	0.888	0.894	0.899	0.910	0.919	0.924	0.930
1.575	0.836	0.841	0.845	0.856	0.864	0.870	0.875

## Calculating Power Dissipation

### Quiescent Supply Current

**Table 2-7 • Quiescent Supply Current Characteristics**

	A3PN010	A3PN015	A3PN020	A3PN060	A3PN125	A3PN250
Typical (25°C)	600 $\mu$ A	1 mA	1 mA	2 mA	2 mA	3 mA
Max. (Commercial)	5 mA	5 mA	5 mA	10 mA	10 mA	20 mA
Max. (Industrial)	8 mA	8 mA	8 mA	15 mA	15 mA	30 mA

Note:  $I_{DD}$  includes VCC, VPUMP, and VCCI, currents.

### Power per I/O Pin

**Table 2-8 • Summary of I/O Input Buffer Power (Per Pin) – Default I/O Software Settings**

	VCCI (V)	Dynamic Power, $P_{AC9}$ ( $\mu$ W/MHz) <sup>1</sup>
<b>Single-Ended</b>		
3.3 V LVTTTL / 3.3 V LVCMOS	3.3	16.45
3.3 V LVTTTL / 3.3 V LVCMOS – Schmitt Trigger	3.3	18.93
3.3 V LVCMOS wide range <sup>2</sup>	3.3	16.45
3.3 V LVCMOS wide range – Schmitt Trigger	3.3	18.93
2.5 V LVCMOS	2.5	4.73
2.5 V LVCMOS – Schmitt Trigger	2.5	6.14
1.8 V LVCMOS	1.8	1.68
1.8 V LVCMOS – Schmitt Trigger	1.8	1.80
1.5 V LVCMOS (JESD8-11)	1.5	0.99
1.5 V LVCMOS (JESD8-11) – Schmitt Trigger	1.5	0.96

**Notes:**

- $P_{AC9}$  is the total dynamic power measured on VCCI.
- All LVCMOS 3.3 V software macros support LVCMOS 3.3 V wide range as specified in the JESD8-B specification.

**Table 2-9 • Summary of I/O Output Buffer Power (per pin) – Default I/O Software Settings<sup>1</sup>**

	$C_{LOAD}$ (pF) <sup>2</sup>	VCCI (V)	Dynamic Power, $P_{AC10}$ ( $\mu$ W/MHz) <sup>3</sup>
<b>Single-Ended</b>			
3.3 V LVTTTL / 3.3 V LVCMOS	10	3.3	162.01
3.3 V LVCMOS wide range <sup>4</sup>	10	3.3	162.01
2.5 V LVCMOS	10	2.5	91.96
1.8 V LVCMOS	10	1.8	46.95
1.5 V LVCMOS (JESD8-11)	10	1.5	32.22

**Notes:**

1. Dynamic power consumption is given for standard load and software default drive strength and output slew.
2. Values for A3PN020, A3PN015, and A3PN010. A3PN060, A3PN125, and A3PN250 correspond to a default loading of 35 pF.
3.  $P_{AC10}$  is the total dynamic power measured on VCCI.
4. All LVCMOS3.3 V software macros support LVCMOS 3.3 V wide range as specified in the JESD8-B specification.

## Power Consumption of Various Internal Resources

**Table 2-10 • Different Components Contributing to Dynamic Power Consumption in ProASIC3 nano Devices**

Parameter	Definition	Device Specific Dynamic Contributions (μW/MHz)					
		A3PN250	A3PN125	A3PN060	A3PN020	A3PN015	A3PN010
P <sub>AC1</sub>	Clock contribution of a Global Rib	11.03	11.03	9.3	9.3	9.3	9.3
P <sub>AC2</sub>	Clock contribution of a Global Spine	1.58	0.81	0.81	0.4	0.4	0.4
P <sub>AC3</sub>	Clock contribution of a VersaTile row	0.81					
P <sub>AC4</sub>	Clock contribution of a VersaTile used as a sequential module	0.12					
P <sub>AC5</sub>	First contribution of a VersaTile used as a sequential module	0.07					
P <sub>AC6</sub>	Second contribution of a VersaTile used as a sequential module	0.29					
P <sub>AC7</sub>	Contribution of a VersaTile used as a combinatorial Module	0.29					
P <sub>AC8</sub>	Average contribution of a routing net	0.70					
P <sub>AC9</sub>	Contribution of an I/O input pin (standard-dependent)	See Table 2-8 on page 2-6.					
P <sub>AC10</sub>	Contribution of an I/O output pin (standard-dependent)	See Table 2-9 on page 2-7.					
P <sub>AC11</sub>	Average contribution of a RAM block during a read operation	25.00			N/A		
P <sub>AC12</sub>	Average contribution of a RAM block during a write operation	30.00			N/A		
P <sub>AC13</sub>	Dynamic contribution for PLL	2.60			N/A		

*Note:* For a different output load, drive strength, or slew rate, Actel recommends using the Actel Power spreadsheet calculator or SmartPower tool in Libero® Integrated Design Environment (IDE) software.

**Table 2-11 • Different Components Contributing to the Static Power Consumption in ProASIC3 nano Devices**

Parameter	Definition	Device Specific Static Power (mW)					
		A3PN250	A3PN125	A3PN060	A3PN020	A3PN015	A3PN010
P <sub>DC1</sub>	Array static power in Active mode	See Table 2-7 on page 2-6.					
P <sub>DC4</sub>	Static PLL contribution <sup>1</sup>	2.55			N/A		
P <sub>DC5</sub>	Bank quiescent power (VCCI-dependent)	See Table 2-7 on page 2-6.					

*Notes:*

1. Minimum contribution of the PLL when running at lowest frequency.
2. For a different output load, drive strength, or slew rate, Actel recommends using the Actel Power spreadsheet calculator or SmartPower tool in Libero IDE.

## Power Calculation Methodology

This section describes a simplified method to estimate power consumption of an application. For more accurate and detailed power estimations, use the SmartPower tool in Actel Libero IDE software.

The power calculation methodology described below uses the following variables:

- The number of PLLs as well as the number and the frequency of each output clock generated
- The number of combinatorial and sequential cells used in the design
- The internal clock frequencies
- The number and the standard of I/O pins used in the design
- The number of RAM blocks used in the design
- Toggle rates of I/O pins as well as VersaTiles—guidelines are provided in [Table 2-12 on page 2-11](#).
- Enable rates of output buffers—guidelines are provided for typical applications in [Table 2-13 on page 2-11](#).
- Read rate and write rate to the memory—guidelines are provided for typical applications in [Table 2-13 on page 2-11](#). The calculation should be repeated for each clock domain defined in the design.

### Methodology

#### Total Power Consumption— $P_{TOTAL}$

$$P_{TOTAL} = P_{STAT} + P_{DYN}$$

$P_{STAT}$  is the total static power consumption.

$P_{DYN}$  is the total dynamic power consumption.

#### Total Static Power Consumption— $P_{STAT}$

$$P_{STAT} = P_{DC1} + N_{INPUTS} * P_{DC2} + N_{OUTPUTS} * P_{DC3}$$

$N_{INPUTS}$  is the number of I/O input buffers used in the design.

$N_{OUTPUTS}$  is the number of I/O output buffers used in the design.

#### Total Dynamic Power Consumption— $P_{DYN}$

$$P_{DYN} = P_{CLOCK} + P_{S-CELL} + P_{C-CELL} + P_{NET} + P_{INPUTS} + P_{OUTPUTS} + P_{MEMORY} + P_{PLL}$$

#### Global Clock Contribution— $P_{CLOCK}$

$$P_{CLOCK} = (P_{AC1} + N_{SPINE} * P_{AC2} + N_{ROW} * P_{AC3} + N_{S-CELL} * P_{AC4}) * F_{CLK}$$

$N_{SPINE}$  is the number of global spines used in the user design—guidelines are provided in [Table 2-12 on page 2-11](#).

$N_{ROW}$  is the number of VersaTile rows used in the design—guidelines are provided in [Table 2-12 on page 2-11](#).

$F_{CLK}$  is the global clock signal frequency.

$N_{S-CELL}$  is the number of VersaTiles used as sequential modules in the design.

$P_{AC1}$ ,  $P_{AC2}$ ,  $P_{AC3}$ , and  $P_{AC4}$  are device-dependent.

#### Sequential Cells Contribution— $P_{S-CELL}$

$$P_{S-CELL} = N_{S-CELL} * (P_{AC5} + \alpha_1 / 2 * P_{AC6}) * F_{CLK}$$

$N_{S-CELL}$  is the number of VersaTiles used as sequential modules in the design. When a multi-tile sequential cell is used, it should be accounted for as 1.

$\alpha_1$  is the toggle rate of VersaTile outputs—guidelines are provided in [Table 2-12 on page 2-11](#).

$F_{CLK}$  is the global clock signal frequency.

**Combinatorial Cells Contribution— $P_{C-CELL}$** 

$$P_{C-CELL} = N_{C-CELL} * \alpha_1 / 2 * P_{AC7} * F_{CLK}$$

$N_{C-CELL}$  is the number of VersaTiles used as combinatorial modules in the design.

$\alpha_1$  is the toggle rate of VersaTile outputs—guidelines are provided in [Table 2-12 on page 2-11](#).

$F_{CLK}$  is the global clock signal frequency.

**Routing Net Contribution— $P_{NET}$** 

$$P_{NET} = (N_{S-CELL} + N_{C-CELL}) * \alpha_1 / 2 * P_{AC8} * F_{CLK}$$

$N_{S-CELL}$  is the number of VersaTiles used as sequential modules in the design.

$N_{C-CELL}$  is the number of VersaTiles used as combinatorial modules in the design.

$\alpha_1$  is the toggle rate of VersaTile outputs—guidelines are provided in [Table 2-12 on page 2-11](#).

$F_{CLK}$  is the global clock signal frequency.

**I/O Input Buffer Contribution— $P_{INPUTS}$** 

$$P_{INPUTS} = N_{INPUTS} * \alpha_2 / 2 * P_{AC9} * F_{CLK}$$

$N_{INPUTS}$  is the number of I/O input buffers used in the design.

$\alpha_2$  is the I/O buffer toggle rate—guidelines are provided in [Table 2-12 on page 2-11](#).

$F_{CLK}$  is the global clock signal frequency.

**I/O Output Buffer Contribution— $P_{OUTPUTS}$** 

$$P_{OUTPUTS} = N_{OUTPUTS} * \alpha_2 / 2 * \beta_1 * P_{AC10} * F_{CLK}$$

$N_{OUTPUTS}$  is the number of I/O output buffers used in the design.

$\alpha_2$  is the I/O buffer toggle rate—guidelines are provided in [Table 2-12 on page 2-11](#).

$\beta_1$  is the I/O buffer enable rate—guidelines are provided in [Table 2-13 on page 2-11](#).

$F_{CLK}$  is the global clock signal frequency.

**RAM Contribution— $P_{MEMORY}$** 

$$P_{MEMORY} = P_{AC11} * N_{BLOCKS} * F_{READ-CLOCK} * \beta_2 + P_{AC12} * N_{BLOCK} * F_{WRITE-CLOCK} * \beta_3$$

$N_{BLOCKS}$  is the number of RAM blocks used in the design.

$F_{READ-CLOCK}$  is the memory read clock frequency.

$\beta_2$  is the RAM enable rate for read operations.

$F_{WRITE-CLOCK}$  is the memory write clock frequency.

$\beta_3$  is the RAM enable rate for write operations—guidelines are provided in [Table 2-13 on page 2-11](#).

**PLL Contribution— $P_{PLL}$** 

$$P_{PLL} = P_{DC4} + P_{AC13} * F_{CLKOUT}$$

$F_{CLKOUT}$  is the output clock frequency.<sup>1</sup>

1. The PLL dynamic contribution depends on the input clock frequency, the number of output clock signals generated by the PLL, and the frequency of each output clock. If a PLL is used to generate more than one output clock, include each output clock in the formula by adding its corresponding contribution ( $P_{AC14} * F_{CLKOUT}$  product) to the total PLL contribution.

## Guidelines

### Toggle Rate Definition

A toggle rate defines the frequency of a net or logic element relative to a clock. It is a percentage. If the toggle rate of a net is 100%, this means that this net switches at half the clock frequency. Below are some examples:

- The average toggle rate of a shift register is 100% because all flip-flop outputs toggle at half of the clock frequency.
- The average toggle rate of an 8-bit counter is 25%:
  - Bit 0 (LSB) = 100%
  - Bit 1 = 50%
  - Bit 2 = 25%
  - ...
  - Bit 7 (MSB) = 0.78125%
  - Average toggle rate =  $(100\% + 50\% + 25\% + 12.5\% + \dots + 0.78125\%) / 8$

### Enable Rate Definition

Output enable rate is the average percentage of time during which tristate outputs are enabled. When nontristate output buffers are used, the enable rate should be 100%.

**Table 2-12 • Toggle Rate Guidelines Recommended for Power Calculation**

Component	Definition	Guideline
$\alpha_1$	Toggle rate of VersaTile outputs	10%
$\alpha_2$	I/O buffer toggle rate	10%

**Table 2-13 • Enable Rate Guidelines Recommended for Power Calculation**

Component	Definition	Guideline
$\beta_1$	I/O output buffer enable rate	100%
$\beta_2$	RAM enable rate for read operations	12.5%
$\beta_3$	RAM enable rate for write operations	12.5%

# User I/O Characteristics

## Timing Model

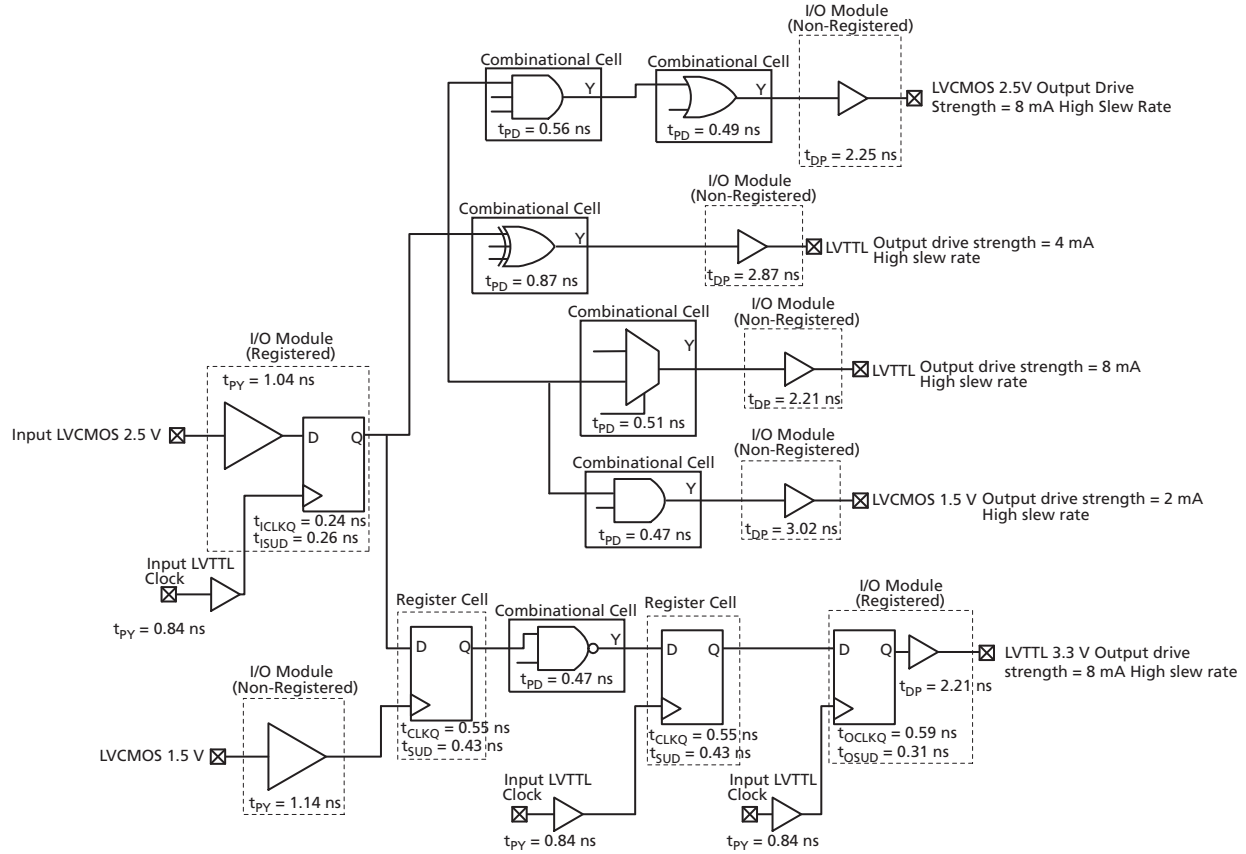

**Figure 2-2 • Timing Model**  
 Operating Conditions: -2 Speed, Commercial Temperature Range ( $T_J = 70^\circ\text{C}$ ), Worst Case  
 $V_{CC} = 1.425$  V, with Default Loading at 10 pF



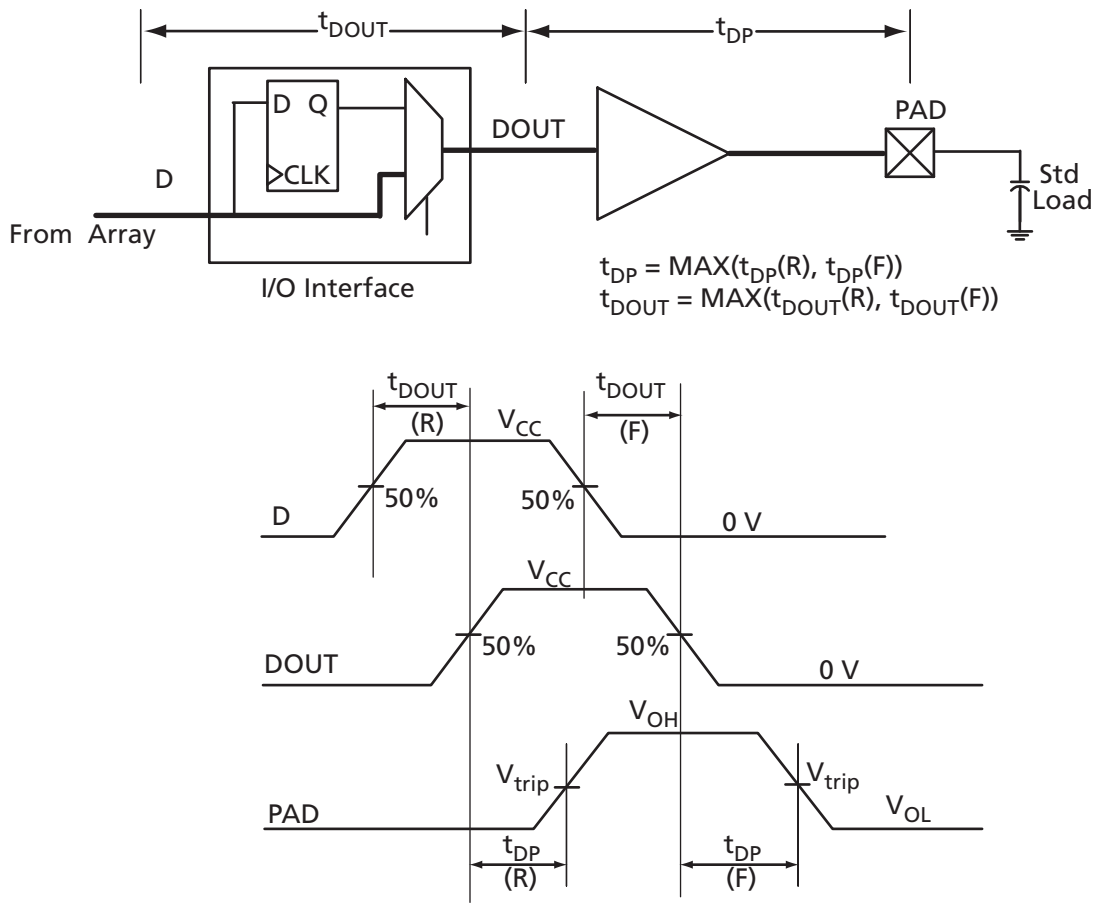

Figure 2-4 • Output Buffer Model and Delays (example)

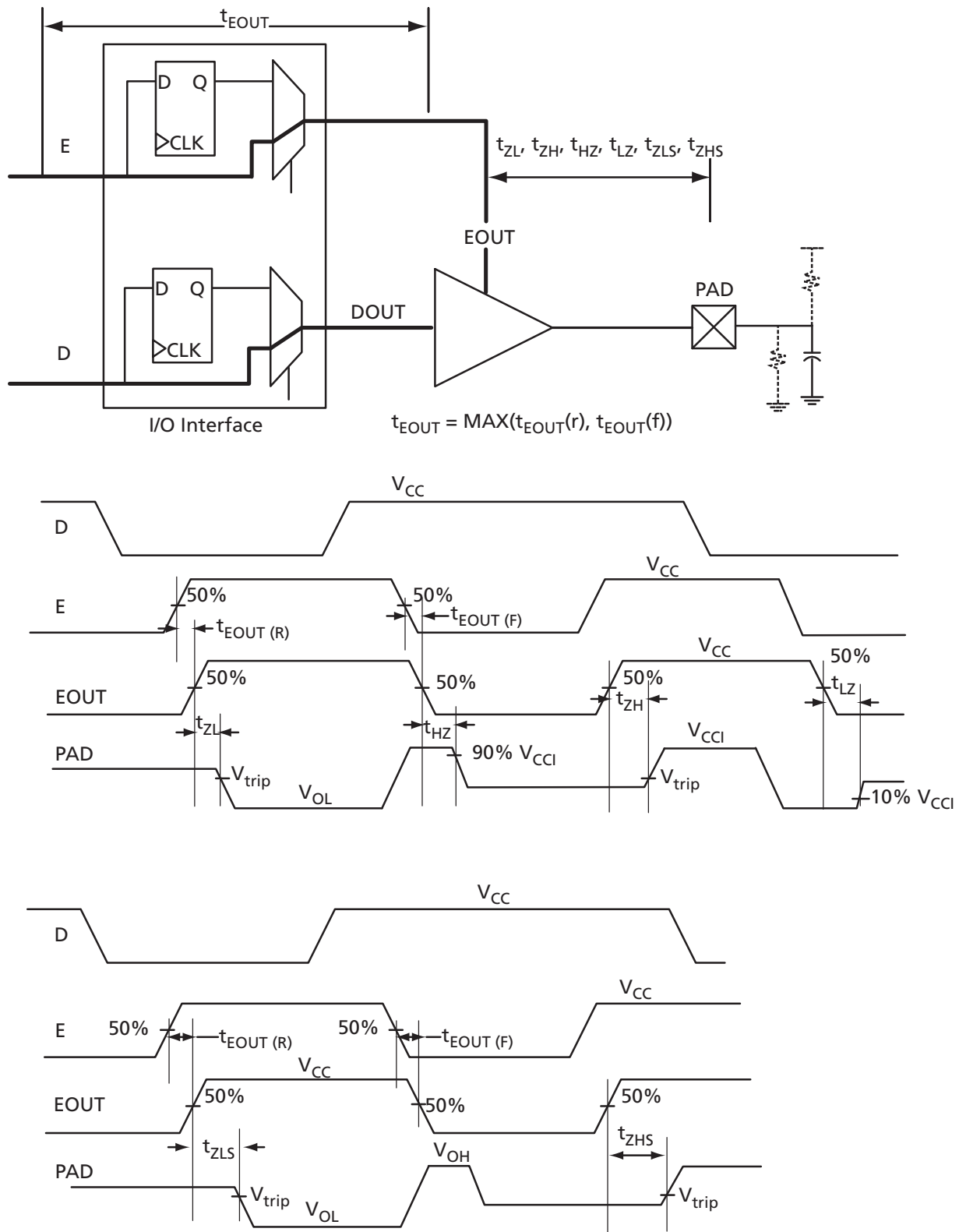

Figure 2-5 • Tristate Output Buffer Timing Model and Delays (example)

## Overview of I/O Performance

### Summary of I/O DC Input and Output Levels – Default I/O Software Settings

**Table 2-14 • Summary of Maximum and Minimum DC Input and Output Levels**  
Applicable to Commercial and Industrial Conditions—Software Default Settings

I/O Standard	Drive Strength	Equivalent Software Default Drive Strength Option <sup>2</sup>	Slew Rate	VIL		VIH		VOL	VOH	I <sub>OL</sub> <sup>1</sup>	I <sub>OH</sub> <sup>1</sup>
				Min. V	Max V	Min. V	Max. V	Max. V	Min. V	mA	mA
3.3 V LVTTTL/ 3.3 V LVC MOS	8 mA	8 mA	High	-0.3	0.8	2	3.6	0.4	2.4	8	8
3.3 V LVC MOS Wide Range	100 $\mu$ A	8 mA	High	-0.3	0.8	2	3.6	0.2	VCCI - 0.2	100 $\mu$ A	100 $\mu$ A
2.5 V LVC MOS	8 mA	8 mA	High	-0.3	0.7	1.7	3.6	0.7	1.7	8	8
1.8 V LVC MOS	4 mA	4 mA	High	-0.3	0.35 * VCCI	0.65 * VCCI	3.6	0.45	VCCI - 0.45	4	4
1.5 V LVC MOS	2 mA	2 mA	High	-0.3	0.35 * VCCI	0.65 * VCCI	3.6	0.25 * VCCI	0.75 * VCCI	2	2

**Notes:**

1. Currents are measured at 85°C junction temperature.
2. Note that 3.3 V LVC MOS wide range is applicable to 100  $\mu$ A drive strength only. The configuration will not operate at the equivalent software default drive strength. These values are for normal ranges only.
3. All LVC MOS 3.3 V software macros support LVC MOS 3.3 V wide range, as specified in the JESD8-B specification.

**Table 2-15 • Summary of Maximum and Minimum DC Input Levels**  
Applicable to Commercial and Industrial Conditions

DC I/O Standards	Commercial <sup>1</sup>		Industrial <sup>2</sup>	
	I <sub>IL</sub> <sup>3</sup>	I <sub>IH</sub> <sup>4</sup>	I <sub>IL</sub> <sup>3</sup>	I <sub>IH</sub> <sup>4</sup>
	$\mu$ A	$\mu$ A	$\mu$ A	$\mu$ A
3.3 V LVTTTL / 3.3 V LVC MOS	10	10	15	15
3.3 V LVC MOS Wide Range	10	10	15	15
2.5 V LVC MOS	10	10	15	15
1.8 V LVC MOS	10	10	15	15
1.5 V LVC MOS	10	10	15	15

**Notes:**

1. Commercial range ( $-20^{\circ}\text{C} < T_A < 70^{\circ}\text{C}$ )
2. Industrial range ( $-40^{\circ}\text{C} < T_A < 85^{\circ}\text{C}$ )
3. I<sub>IL</sub> is the input leakage current per I/O pin over recommended operation conditions where  $-0.3\text{ V} < V_{IN} < V_{IL}$ .
4. I<sub>IH</sub> is the input leakage current per I/O pin over recommended operating conditions  $V_{IH} < V_{IN} < V_{CCI}$ . Input current is larger when operating outside recommended ranges.

## Summary of I/O Timing Characteristics – Default I/O Software Settings

**Table 2-16 • Summary of AC Measuring Points**

Standard	Measuring Trip Point (Vtrip)
3.3 V LVTTTL / 3.3 V LVCMOS	1.4 V
3.3 V LVCMOS Wide Range	1.4 V
2.5 V LVCMOS	1.2 V
1.8 V LVCMOS	0.90 V
1.5 V LVCMOS	0.75 V

**Table 2-17 • I/O AC Parameter Definitions**

Parameter	Parameter Definition
$t_{DP}$	Data to Pad delay through the Output Buffer
$t_{PY}$	Pad to Data delay through the Input Buffer
$t_{DOUT}$	Data to Output Buffer delay through the I/O interface
$t_{EOUT}$	Enable to Output Buffer Tristate Control delay through the I/O interface
$t_{DIN}$	Input Buffer to Data delay through the I/O interface
$t_{HZ}$	Enable to Pad delay through the Output Buffer—HIGH to Z
$t_{ZH}$	Enable to Pad delay through the Output Buffer—Z to HIGH
$t_{LZ}$	Enable to Pad delay through the Output Buffer—LOW to Z
$t_{ZL}$	Enable to Pad delay through the Output Buffer—Z to LOW
$t_{ZHS}$	Enable to Pad delay through the Output Buffer with delayed enable—Z to HIGH
$t_{ZLS}$	Enable to Pad delay through the Output Buffer with delayed enable—Z to LOW

**Table 2-18 • Summary of I/O Timing Characteristics—Software Default Settings (at 35 pF)**  
 STD Speed Grade, Commercial-Case Conditions:  $T_J = 70^\circ\text{C}$ , Worst Case  $V_{CC} = 1.425\text{ V}$   
 For A3PN060, A3PN125, and A3PN250

I/O Standard	Drive Strength (mA)	Equivalent Software Default Drive Strength Option <sup>1</sup>	Slew Rate	Capacitive Load (pF)	$t_{DOUT}$ (ns)	$t_{DP}$ (ns)	$t_{DIN}$ (ns)	$t_{PY}$ (ns)	$t_{PYS}$ (ns)	$t_{EOUT}$ (ns)	$t_{ZL}$ (ns)	$t_{ZH}$ (ns)	$t_{LZ}$ (ns)	$t_{HZ}$ (ns)
3.3 V LVTTTL / 3.3 V LVCMOS	8	8 mA	High	35	0.60	4.57	0.04	1.13	1.52	0.43	4.64	3.92	2.60	3.14
3.3 V LVCMOS Wide Range	100 $\mu\text{A}$	8 mA	High	35	0.60	6.78	0.04	1.57	2.18	0.43	6.78	5.72	3.72	4.35
2.5 V LVCMOS	8	8 mA	High	35	0.60	4.94	0.04	1.43	1.63	0.43	4.71	4.94	2.60	2.98
1.8 V LVCMOS	4	4 mA	High	35	0.60	6.53	0.04	1.35	1.90	0.43	5.53	6.53	2.62	2.89
1.5 V LVCMOS	2	2 mA	High	35	0.60	7.86	0.04	1.56	2.14	0.43	6.45	7.86	2.66	2.83

**Notes:**

- Note that 3.3 V LVCMOS wide range is applicable to 100  $\mu\text{A}$  drive strength only. The configuration will not operate at the equivalent software default drive strength. These values are for normal ranges only.
- All LVCMOS 3.3 V software macros support LVCMOS 3.3 V wide range, as specified in the JESD8-B specification.
- For specific junction temperature and voltage supply levels, refer to [Table 2-6 on page 2-5](#) for derating values.

**Table 2-19 • Summary of I/O Timing Characteristics—Software Default Settings (at 10 pF)**  
 STD Speed Grade, Commercial-Case Conditions:  $T_J = 70^\circ\text{C}$ , Worst Case  $V_{CC} = 1.425\text{ V}$   
 For A3PN020, A3PN015, and A3PN010

I/O Standard	Drive Strength (mA)	Equivalent Software Default Drive Strength Option <sup>1</sup>	Slew Rate	Capacitive Load (pF)	$t_{DOUT}$ (ns)	$t_{DP}$ (ns)	$t_{DIN}$ (ns)	$t_{PY}$ (ns)	$t_{PYS}$ (ns)	$t_{EOUT}$ (ns)	$t_{ZL}$ (ns)	$t_{ZH}$ (ns)	$t_{LZ}$ (ns)	$t_{HZ}$ (ns)
3.3 V LVTTTL / 3.3 V LVCMOS	8	8 mA	High	10	0.60	2.73	0.04	1.13	1.52	0.43	2.77	2.23	2.60	3.14
3.3 V LVCMOS Wide Range	100 $\mu\text{A}$	8 mA	High	10	0.60	3.94	0.04	1.57	2.18	0.43	3.94	3.16	3.72	4.35
2.5 V LVCMOS	8	8 mA	High	10	0.60	2.76	0.04	1.43	1.63	0.43	2.80	2.60	2.60	2.98
1.8 V LVCMOS	4	4 mA	High	10	0.60	3.22	0.04	1.35	1.90	0.43	3.24	3.22	2.62	2.89
1.5 V LVCMOS	2	2 mA	High	10	0.60	3.76	0.04	1.56	2.14	0.43	3.74	3.76	2.66	2.83

**Notes:**

- Note that 3.3 V LVCMOS wide range is applicable to 100  $\mu\text{A}$  drive strength only. The configuration will not operate at the equivalent software default drive strength. These values are for normal ranges only.
- All LVCMOS 3.3 V software macros support LVCMOS 3.3 V wide range, as specified in the JESD8-B specification.
- For specific junction temperature and voltage supply levels, refer to [Table 2-6 on page 2-5](#) for derating values.

## Detailed I/O DC Characteristics

**Table 2-20 • Input Capacitance**

Symbol	Definition	Conditions	Min.	Max.	Units
$C_{IN}$	Input capacitance	$V_{IN} = 0, f = 1.0 \text{ MHz}$		8	pF
$C_{INCLK}$	Input capacitance on the clock pin	$V_{IN} = 0, f = 1.0 \text{ MHz}$		8	pF

**Table 2-21 • I/O Output Buffer Maximum Resistances <sup>1</sup>**

Standard	Drive Strength	$R_{PULL-DOWN}$ ( $\Omega$ ) <sup>2</sup>	$R_{PULL-UP}$ ( $\Omega$ ) <sup>3</sup>
3.3 V LVTTTL / 3.3 V LVCMOS	2 mA	100	300
	4 mA	100	300
	6 mA	50	150
	8 mA	50	150
3.3 V LVCMOS Wide Range	100 $\mu$ A	Same as equivalent software default drive	
2.5 V LVCMOS	2 mA	100	200
	4 mA	100	200
	6 mA	50	100
	8 mA	50	100
1.8 V LVCMOS	2 mA	200	225
	4 mA	100	112
1.5 V LVCMOS	2 mA	200	224

**Notes:**

1. These maximum values are provided for informational reasons only. Minimum output buffer resistance values depend on  $V_{CC}$ , drive strength selection, temperature, and process. For board design considerations and detailed output buffer resistances, use the corresponding IBIS models located on the Actel website at <http://www.actel.com/download/ibis/default.aspx>.
2.  $R_{(PULL-DOWN-MAX)} = (VOL_{spec}) / IOL_{spec}$
3.  $R_{(PULL-UP-MAX)} = (VCC_{max} - VOH_{spec}) / IOH_{spec}$

**Table 2-22 • I/O Weak Pull-Up/Pull-Down Resistances  
Minimum and Maximum Weak Pull-Up/Pull-Down Resistance Values**

VCCI	$R_{(WEAK PULL-UP)}$ <sup>1</sup> ( $\Omega$ )		$R_{(WEAK PULL-DOWN)}$ <sup>2</sup> ( $\Omega$ )	
	Min.	Max.	Min.	Max.
3.3 V	10 K	45 K	10 K	45 K
3.3 V (wide range I/Os)	10 K	45 K	10 K	45 K
2.5 V	11 K	55 K	12 K	74 K
1.8 V	18 K	70 K	17 K	110 K
1.5 V	19 K	90 K	19 K	140 K

**Notes:**

1.  $R_{(WEAK PULL-UP-MAX)} = (VCC_{max} - VOH_{spec}) / I_{(WEAK PULL-UP-MIN)}$
2.  $R_{(WEAK PULLDOWN-MAX)} = (VOL_{spec}) / I_{(WEAK PULLDOWN-MIN)}$

**Table 2-23 • I/O Short Currents  $I_{OSH}/I_{OSL}$** 

	Drive Strength	$I_{OSL}$ (mA)*	$I_{OSH}$ (mA)*
3.3 V LVTTTL / 3.3 V LVCMOS	2 mA	25	27
	4 mA	25	27
	6 mA	51	54
	8 mA	51	54
3.3 V LVCMOS Wide Range	100 $\mu$ A	Same as equivalent software default drive	
2.5 V LVCMOS	2 mA	16	18
	4 mA	16	18
	6 mA	32	37
	8 mA	32	37
1.8 V LVCMOS	2 mA	9	11
	4 mA	17	22
1.5 V LVCMOS	2 mA	13	16

Note: \* $T_J = 100^\circ\text{C}$

The length of time an I/O can withstand  $I_{OSH}/I_{OSL}$  events depends on the junction temperature. The reliability data below is based on a 3.3 V, 8 mA I/O setting, which is the worst case for this type of analysis.

For example, at  $100^\circ\text{C}$ , the short current condition would have to be sustained for more than six months to cause a reliability concern. The I/O design does not contain any short circuit protection, but such protection would only be needed in extremely prolonged stress conditions.

**Table 2-24 • Duration of Short Circuit Event before Failure**

Temperature	Time before Failure
$-40^\circ\text{C}$	> 20 years
$-20^\circ\text{C}$	> 20 years
$0^\circ\text{C}$	> 20 years
$25^\circ\text{C}$	> 20 years
$70^\circ\text{C}$	5 years
$85^\circ\text{C}$	2 years
$100^\circ\text{C}$	6 months

**Table 2-25 • Schmitt Trigger Input Hysteresis**  
**Hysteresis Voltage Value (Typ.) for Schmitt Mode Input Buffers**

Input Buffer Configuration	Hysteresis Value (typ.)
3.3 V LVTTTL / LVCMOS (Schmitt trigger mode)	240 mV
2.5 V LVCMOS (Schmitt trigger mode)	140 mV
1.8 V LVCMOS (Schmitt trigger mode)	80 mV
1.5 V LVCMOS (Schmitt trigger mode)	60 mV

**Table 2-26 • I/O Input Rise Time, Fall Time, and Related I/O Reliability**

Input Buffer	Input Rise/Fall Time (min.)	Input Rise/Fall Time (max.)	Reliability
LVTTTL/LVCMOS (Schmitt trigger disabled)	No requirement	10 ns *	20 years (100°C)
LVTTTL/LVCMOS (Schmitt trigger enabled)	No requirement	No requirement, but input noise voltage cannot exceed Schmitt hysteresis	20 years (100°C)

*Note:* The maximum input rise/fall time is related to the noise induced into the input buffer trace. If the noise is low, then the rise time and fall time of input buffers can be increased beyond the maximum value. The longer the rise/fall times, the more susceptible the input signal is to the board noise. Actel recommends signal integrity evaluation/characterization of the system to ensure that there is no excessive noise coupling into input signals.

## Single-Ended I/O Characteristics

### 3.3 V LVTTTL / 3.3 V LVCMOS

Low-Voltage Transistor–Transistor Logic (LVTTTL) is a general-purpose standard (EIA/JESD) for 3.3 V applications. It uses an LVTTTL input buffer and push-pull output buffer.

**Table 2-27 • Minimum and Maximum DC Input and Output Levels**

3.3 V LVTTTL / 3.3 V LVCMOS	VIL		VIH		VOL	VOH	I <sub>OL</sub>	I <sub>OH</sub>	I <sub>OSL</sub>	I <sub>OSH</sub>	I <sub>IL</sub> <sup>1</sup>	I <sub>IH</sub> <sup>2</sup>
	Min., V	Max., V	Min., V	Max., V	Max., V	Min., V	mA	mA	Max., mA <sup>3</sup>	Max., mA <sup>3</sup>	μA <sup>4</sup>	μA <sup>4</sup>
2 mA	-0.3	0.8	2	3.6	0.4	2.4	2	2	25	27	10	10
4 mA	-0.3	0.8	2	3.6	0.4	2.4	4	4	25	27	10	10
6 mA	-0.3	0.8	2	3.6	0.4	2.4	6	6	51	54	10	10
8 mA	-0.3	0.8	2	3.6	0.4	2.4	8	8	51	54	10	10

**Notes:**

1.  $I_{IL}$  is the input leakage current per I/O pin over recommended operation conditions where  $-0.3\text{ V} < V_{IN} < V_{IL}$ .
2.  $I_{IH}$  is the input leakage current per I/O pin over recommended operating conditions  $V_{IH} < V_{IN} < V_{CCI}$ . Input current is larger when operating outside recommended ranges.
3. Currents are measured at high temperature (100°C junction temperature) and maximum voltage.
4. Currents are measured at 85°C junction temperature.
5. Software default selection highlighted in gray.

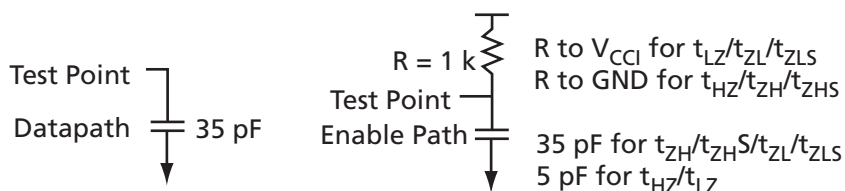

**Figure 2-6 • AC Loading**

**Table 2-28 • 3.3 V LVTTTL/LVCMOS AC Waveforms, Measuring Points, and Capacitive Loads**

Input LOW (V)	Input HIGH (V)	Measuring Point* (V)	C <sub>LOAD</sub> (pF)
0	3.3	1.4	10

**Notes:**

1. Measuring point =  $V_{trip}$ . See [Table 2-16 on page 2-17](#) for a complete table of trip points.
2. Capacitive Load for A3PN060, A3PN125, and A3PN250 is 35 pF.

## Timing Characteristics

Table 2-29 • 3.3 V LVTTTL / 3.3 V LVCMOS Low Slew

Commercial-Case Conditions:  $T_J = 70^\circ\text{C}$ , Worst-Case  $V_{CC} = 1.425\text{ V}$ , Worst-Case  $V_{CCI} = 3.0\text{ V}$   
 Software Default Load at 35 pF for A3PN060, A3PN125, A3PN250

Drive Strength	Speed Grade	$t_{DOUT}$	$t_{DP}$	$t_{DIN}$	$t_{PY}$	$t_{PYS}$	$t_{EOUT}$	$t_{ZL}$	$t_{ZH}$	$t_{LZ}$	$t_{HZ}$	Units
2 mA	Std.	0.60	9.70	0.04	1.13	1.52	0.43	9.88	8.82	2.31	2.50	ns
	-1	0.51	8.26	0.04	0.96	1.29	0.36	8.40	7.50	1.96	2.13	ns
	-2	0.45	7.25	0.03	0.84	1.13	0.32	7.37	6.59	1.72	1.87	ns
4 mA	Std.	0.60	9.70	0.04	1.13	1.52	0.43	9.88	8.82	2.31	2.50	ns
	-1	0.51	8.26	0.04	0.96	1.29	0.36	8.40	7.50	1.96	2.13	ns
	-2	0.45	7.25	0.03	0.84	1.13	0.32	7.37	6.59	1.72	1.87	ns
6 mA	Std.	0.60	6.90	0.04	1.13	1.52	0.43	7.01	6.22	2.61	3.01	ns
	-1	0.51	5.87	0.04	0.96	1.29	0.36	5.97	5.29	2.22	2.56	ns
	-2	0.45	5.15	0.03	0.84	1.13	0.32	5.24	4.64	1.95	2.25	ns
8 mA	Std.	0.60	6.90	0.04	1.13	1.52	0.43	7.01	6.22	2.61	3.01	ns
	-1	0.51	5.87	0.04	0.96	1.29	0.36	5.97	5.29	2.22	2.56	ns
	-2	0.45	5.15	0.03	0.84	1.13	0.32	5.24	4.64	1.95	2.25	ns

Note: For specific junction temperature and voltage supply levels, refer to Table 2-6 on page 2-5 for derating values.

Table 2-30 • 3.3 V LVTTTL / 3.3 V LVCMOS High Slew

Commercial-Case Conditions:  $T_J = 70^\circ\text{C}$ , Worst-Case  $V_{CC} = 1.425\text{ V}$ , Worst-Case  $V_{CCI} = 3.0\text{ V}$   
 Software Default Load at 35 pF for A3PN060, A3PN125, A3PN250

Drive Strength	Speed Grade	$t_{DOUT}$	$t_{DP}$	$t_{DIN}$	$t_{PY}$	$t_{PYS}$	$t_{EOUT}$	$t_{ZL}$	$t_{ZH}$	$t_{LZ}$	$t_{HZ}$	Units
2 mA	Std.	0.60	7.19	0.04	1.13	1.52	0.43	7.32	6.40	2.30	2.62	ns
	-1	0.51	6.12	0.04	0.96	1.29	0.36	6.22	5.44	1.96	2.23	ns
	-2	0.45	5.37	0.03	0.84	1.13	0.32	5.46	4.78	1.72	1.96	ns
4 mA	Std.	0.60	7.19	0.04	1.13	1.52	0.43	7.32	6.40	2.30	2.62	ns
	-1	0.51	6.12	0.04	0.96	1.29	0.36	6.22	5.44	1.96	2.23	ns
	-2	0.45	5.37	0.03	0.84	1.13	0.32	5.46	4.78	1.72	1.96	ns
6 mA	Std.	0.60	4.57	0.04	1.13	1.52	0.43	4.64	3.92	2.60	3.14	ns
	-1	0.51	3.89	0.04	0.96	1.29	0.36	3.95	3.33	2.22	2.67	ns
	-2	0.45	3.41	0.03	0.84	1.13	0.32	3.47	2.93	1.95	2.34	ns
8 mA	Std.	0.60	4.57	0.04	1.13	1.52	0.43	4.64	3.92	2.60	3.14	ns
	-1	0.51	3.89	0.04	0.96	1.29	0.36	3.95	3.33	2.22	2.67	ns
	-2	0.45	3.41	0.03	0.84	1.13	0.32	3.47	2.93	1.95	2.34	ns

## Notes:

1. Software default selection highlighted in gray.
2. For specific junction temperature and voltage supply levels, refer to Table 2-6 on page 2-5 for derating values.

**Table 2-31 • 3.3 V LVTTTL / 3.3 V LVCMOS Low Slew**

Commercial-Case Conditions:  $T_J = 70^\circ\text{C}$ , Worst-Case VCC = 1.425 V, Worst-Case VCCI = 3.0 V  
 Software Default Load at 10 pF for A3PN020, A3PN015, A3PN010

Drive Strength	Speed Grade	$t_{DOUT}$	$t_{DP}$	$t_{DIN}$	$t_{PY}$	$t_{PYS}$	$t_{EOUT}$	$t_{ZL}$	$t_{ZH}$	$t_{LZ}$	$t_{HZ}$	Units
2 mA	Std.	0.60	5.48	0.04	1.13	1.52	0.43	5.58	5.21	2.31	2.50	ns
	-1	0.51	4.66	0.04	0.96	1.29	0.36	4.74	4.43	1.96	2.13	ns
	-2	0.45	4.09	0.03	0.84	1.13	0.32	4.16	3.89	1.72	1.87	ns
4 mA	Std.	0.60	5.48	0.04	1.13	1.52	0.43	5.58	5.21	2.31	2.50	ns
	-1	0.51	4.66	0.04	0.96	1.29	0.36	4.74	4.43	1.96	2.13	ns
	-2	0.45	4.09	0.03	0.84	1.13	0.32	4.16	3.89	1.72	1.87	ns
6 mA	Std.	0.60	4.33	0.04	1.13	1.52	0.43	4.40	4.14	2.61	3.01	ns
	-1	0.51	3.69	0.04	0.96	1.29	0.36	3.75	3.52	2.22	2.56	ns
	-2	0.45	3.24	0.03	0.84	1.13	0.32	3.29	3.09	1.95	2.25	ns
8 mA	Std.	0.60	4.33	0.04	1.13	1.52	0.43	4.40	4.14	2.61	3.01	ns
	-1	0.51	3.69	0.04	0.96	1.29	0.36	3.75	3.52	2.22	2.56	ns
	-2	0.45	3.24	0.03	0.84	1.13	0.32	3.29	3.09	1.95	2.25	ns

Note: For specific junction temperature and voltage supply levels, refer to Table 2-6 on page 2-5 for derating values.

**Table 2-32 • 3.3 V LVTTTL / 3.3 V LVCMOS High Slew**

Commercial-Case Conditions:  $T_J = 70^\circ\text{C}$ , Worst-Case VCC = 1.425 V, Worst-Case VCCI = 3.0 V  
 Software Default Load at 10 pF for A3PN020, A3PN015, A3PN010

Drive Strength	Speed Grade	$t_{DOUT}$	$t_{DP}$	$t_{DIN}$	$t_{PY}$	$t_{PYS}$	$t_{EOUT}$	$t_{ZL}$	$t_{ZH}$	$t_{LZ}$	$t_{HZ}$	Units
2 mA	Std.	0.60	3.56	0.04	1.13	1.52	0.43	3.62	3.03	2.30	2.62	ns
	-1	0.51	3.03	0.04	0.96	1.29	0.36	3.08	2.58	1.96	2.23	ns
	-2	0.45	2.66	0.03	0.84	1.13	0.32	2.70	2.26	1.72	1.96	ns
4 mA	Std.	0.60	3.56	0.04	1.13	1.52	0.43	3.62	3.03	2.30	2.62	ns
	-1	0.51	3.03	0.04	0.96	1.29	0.36	3.08	2.58	1.96	2.23	ns
	-2	0.45	2.66	0.03	0.84	1.13	0.32	2.70	2.26	1.72	1.96	ns
6 mA	Std.	0.60	2.73	0.04	1.13	1.52	0.43	2.77	2.23	2.60	3.14	ns
	-1	0.51	2.32	0.04	0.96	1.29	0.36	2.36	1.90	2.22	2.67	ns
	-2	0.45	2.04	0.03	0.84	1.13	0.32	2.07	1.67	1.95	2.34	ns
8 mA	Std.	0.60	2.73	0.04	1.13	1.52	0.43	2.77	2.23	2.60	3.14	ns
	-1	0.51	2.32	0.04	0.96	1.29	0.36	2.36	1.90	2.22	2.67	ns
	-2	0.45	2.04	0.03	0.84	1.13	0.32	2.07	1.67	1.95	2.34	ns

Notes:

1. Software default selection highlighted in gray.
2. For specific junction temperature and voltage supply levels, refer to Table 2-6 on page 2-5 for derating values.

### 3.3 V LVCMOS Wide Range

Table 2-33 • Minimum and Maximum DC Input and Output Levels for 3.3 V LVCMOS Wide Range

3.3 V LVCMOS Wide Range	Equivalent Software Default Drive Strength Option <sup>3</sup>	VIL		VIH		VOL	VOH	I <sub>OL</sub>	I <sub>OH</sub>	I <sub>IL</sub> <sup>1</sup>	I <sub>IH</sub> <sup>2</sup>
		Min. V	Max. V	Min. V	Max. V	Max. V	Min. V	mA	mA	μA <sup>4</sup>	μA <sup>4</sup>
100 μA	2 mA	-0.3	0.8	2	3.6	0.2	VDD - 0.2	100	100	10	10
100 μA	4 mA	-0.3	0.8	2	3.6	0.2	VDD - 0.2	100	100	10	10
100 μA	6 mA	-0.3	0.8	2	3.6	0.2	VDD - 0.2	100	100	10	10
100 μA	8 mA	-0.3	0.8	2	3.6	0.2	VDD - 0.2	100	100	10	10

*Notes:*

1. I<sub>IL</sub> is the input leakage current per I/O pin over recommended operation conditions where  $-0.3\text{ V} < V_{IN} < V_{IL}$ .
2. I<sub>IH</sub> is the input leakage current per I/O pin over recommended operating conditions  $V_{IH} < V_{IN} < V_{CCI}$ . Input current is larger when operating outside recommended ranges.
3. Note that 3.3 V LVCMOS wide range is applicable to 100 μA drive strength only. The configuration will not operate at the equivalent software default drive strength. These values are for normal ranges only.
4. Currents are measured at 85°C junction temperature.
5. All LVMCOS 3.3 V software macros support LVCMOS 3.3 V Wide Range, as specified in the JESD8-B specification.
6. Software default selection highlighted in gray.

### Timing Characteristics

**Table 2-34 • 3.3 V LVCMOS Wide Range Low Slew**

Commercial-Case Conditions:  $T_J = 70^\circ\text{C}$ , Worst-Case  $V_{CC} = 1.425\text{ V}$ , Worst-Case  $V_{CCI} = 2.7\text{ V}$   
 Software Default Load at 35 pF for A3PN060, A3PN125, A3PN250

Drive Strength	Equivalent Software Default Drive Strength Option <sup>1</sup>	Speed Grade	$t_{DOUT}$	$t_{DP}$	$t_{DIN}$	$t_{PY}$	$t_{PYS}$	$t_{EOUT}$	$t_{ZL}$	$t_{ZH}$	$t_{LZ}$	$t_{HZ}$	Units
100 $\mu\text{A}$	2 mA	Std.	0.60	14.73	0.04	1.57	2.18	0.43	14.73	13.16	3.26	3.38	ns
		-1	0.51	12.53	0.04	1.33	1.85	0.36	12.53	11.19	2.77	2.87	ns
		-2	0.45	11.00	0.03	1.17	1.62	0.32	11.00	9.83	2.43	2.52	ns
100 $\mu\text{A}$	4 mA	Std.	0.60	14.73	0.04	1.57	2.18	0.43	14.73	13.16	3.26	3.38	ns
		-1	0.51	12.53	0.04	1.33	1.85	0.36	12.53	11.19	2.77	2.87	ns
		-2	0.45	11.00	0.03	1.17	1.62	0.32	11.00	9.83	2.43	2.52	ns
100 $\mu\text{A}$	6 mA	Std.	0.60	10.38	0.04	1.57	2.18	0.43	10.38	9.21	3.72	4.16	ns
		-1	0.51	8.83	0.04	1.33	1.85	0.36	8.83	7.83	3.17	3.54	ns
		-2	0.45	7.75	0.03	1.17	1.62	0.32	7.75	6.88	2.78	3.11	ns
100 $\mu\text{A}$	8 mA	Std.	0.60	10.38	0.04	1.57	2.18	0.43	10.38	9.21	3.72	4.16	ns
		-1	0.51	8.83	0.04	1.33	1.85	0.36	8.83	7.83	3.17	3.54	ns
		-2	0.45	7.75	0.03	1.17	1.62	0.32	7.75	6.88	2.78	3.11	ns

**Notes:**

1. Note that 3.3 V LVCMOS wide range is applicable to 100  $\mu\text{A}$  drive strength only. The configuration will not operate at the equivalent software default drive strength. These values are for normal ranges only.
2. For specific junction temperature and voltage supply levels, refer to [Table 2-6 on page 2-5](#) for derating values.

**Table 2-35 • 3.3 V LVC MOS Wide Range High Slew**

Commercial-Case Conditions:  $T_J = 70^\circ\text{C}$ , Worst-Case  $V_{CC} = 1.425\text{ V}$ , Worst-Case  $V_{CCI} = 2.7\text{ V}$   
 Software Default Load at 35 pF for A3PN060, A3PN125, A3PN250

Drive Strength	Equivalent Software Default Drive Strength Option <sup>1</sup>	Speed Grade	$t_{DOUT}$	$t_{DP}$	$t_{DIN}$	$t_{PY}$	$t_{PYS}$	$t_{EOUT}$	$t_{ZL}$	$t_{ZH}$	$t_{LZ}$	$t_{HZ}$	Units
100 $\mu\text{A}$	2 mA	Std.	0.60	10.83	0.04	1.57	2.18	0.43	10.83	9.48	3.25	3.56	ns
		-1	0.51	9.22	0.04	1.33	1.85	0.36	9.22	8.06	2.77	3.03	ns
		-2	0.45	8.09	0.03	1.17	1.62	0.32	8.09	7.08	2.43	2.66	ns
100 $\mu\text{A}$	4 mA	Std.	0.60	10.83	0.04	1.57	2.18	0.43	10.83	9.48	3.25	3.56	ns
		-1	0.51	9.22	0.04	1.33	1.85	0.36	9.22	8.06	2.77	3.03	ns
		-2	0.45	8.09	0.03	1.17	1.62	0.32	8.09	7.08	2.43	2.66	ns
100 $\mu\text{A}$	6 mA	Std.	0.60	6.78	0.04	1.57	2.18	0.43	6.78	5.72	3.72	4.35	ns
		-1	0.51	5.77	0.04	1.33	1.85	0.36	5.77	4.87	3.16	3.70	ns
		-2	0.45	5.06	0.03	1.17	1.62	0.32	5.06	4.27	2.78	3.25	ns
100 $\mu\text{A}$	8 mA	Std.	0.60	6.78	0.04	1.57	2.18	0.43	6.78	5.72	3.72	4.35	ns
		-1	0.51	5.77	0.04	1.33	1.85	0.36	5.77	4.87	3.16	3.70	ns
		-2	0.45	5.06	0.03	1.17	1.62	0.32	5.06	4.27	2.78	3.25	ns

**Notes:**

1. Note that 3.3 V LVC MOS wide range is applicable to 100  $\mu\text{A}$  drive strength only. The configuration will not operate at the equivalent software default drive strength. These values are for normal ranges only.
2. For specific junction temperature and voltage supply levels, refer to [Table 2-6 on page 2-5](#) for derating values.
3. Software default selection highlighted in gray.

**Table 2-36 • 3.3 V LVC MOS Wide Range Low Slew**  
 Commercial-Case Conditions:  $T_J = 70^\circ\text{C}$ , Worst-Case  $V_{CC} = 1.425\text{ V}$ , Worst-Case  $V_{CCI} = 2.7\text{ V}$   
 Software Default Load at 35 pF for A3PN020, A3PN015, A3PN010

Drive Strength	Equivalent Software Default Drive Strength Option <sup>1</sup>	Speed Grade	$t_{DOUT}$	$t_{DP}$	$t_{DIN}$	$t_{PY}$	$t_{PYS}$	$t_{EOUT}$	$t_{ZL}$	$t_{ZH}$	$t_{LZ}$	$t_{HZ}$	Units
100 $\mu\text{A}$	2 mA	Std.	0.60	8.20	0.04	1.57	2.18	0.43	8.20	7.68	3.26	3.38	ns
		-1	0.51	6.97	0.04	1.33	1.85	0.36	6.97	6.53	2.77	2.87	ns
		-2	0.45	6.12	0.03	1.17	1.62	0.32	6.12	5.73	2.43	2.52	ns
100 $\mu\text{A}$	4 mA	Std.	0.60	8.20	0.04	1.57	2.18	0.43	8.20	7.68	3.26	3.38	ns
		-1	0.51	6.97	0.04	1.33	1.85	0.36	6.97	6.53	2.77	2.87	ns
		-2	0.45	6.12	0.03	1.17	1.62	0.32	6.12	5.73	2.43	2.52	ns
100 $\mu\text{A}$	6 mA	Std.	0.60	6.42	0.04	1.57	2.18	0.43	6.42	6.05	3.72	4.16	ns
		-1	0.51	5.46	0.04	1.33	1.85	0.36	5.46	5.14	3.17	3.54	ns
		-2	0.45	4.79	0.03	1.17	1.62	0.32	4.79	4.52	2.78	3.11	ns
100 $\mu\text{A}$	8 mA	Std.	0.60	6.42	0.04	1.57	2.18	0.43	6.42	6.05	3.72	4.16	ns
		-1	0.51	5.46	0.04	1.33	1.85	0.36	5.46	5.14	3.17	3.54	ns
		-2	0.45	4.79	0.03	1.17	1.62	0.32	4.79	4.52	2.78	3.11	ns

**Notes:**

- Note that 3.3 V LVC MOS wide range is applicable to 100  $\mu\text{A}$  drive strength only. The configuration will not operate at the equivalent software default drive strength. These values are for normal ranges only.
- For specific junction temperature and voltage supply levels, refer to [Table 2-6 on page 2-5](#) for derating values.

**Table 2-37 • 3.3 V LVC MOS Wide Range High Slew**

Commercial-Case Conditions:  $T_J = 70^\circ\text{C}$ , Worst-Case  $V_{CC} = 1.425\text{ V}$ , Worst-Case  $V_{CCI} = 2.7\text{ V}$   
 Software Default Load at 35 pF for A3PN020, A3PN015, A3PN010

Drive Strength	Equivalent Software Default Drive Strength Option <sup>1</sup>	Speed Grade	$t_{DOUT}$	$t_{DP}$	$t_{DIN}$	$t_{PY}$	$t_{PYS}$	$t_{EOUT}$	$t_{ZL}$	$t_{ZH}$	$t_{LZ}$	$t_{HZ}$	Units
100 $\mu\text{A}$	2 mA	Std.	0.60	5.23	0.04	1.57	2.18	0.43	5.23	4.37	3.25	3.56	ns
		-1	0.51	4.45	0.04	1.33	1.85	0.36	4.45	3.71	2.77	3.03	ns
		-2	0.45	3.90	0.03	1.17	1.62	0.32	3.90	3.26	2.43	2.66	ns
100 $\mu\text{A}$	4 mA	Std.	0.60	5.23	0.04	1.57	2.18	0.43	5.23	4.37	3.25	3.56	ns
		-1	0.51	4.45	0.04	1.33	1.85	0.36	4.45	3.71	2.77	3.03	ns
		-2	0.45	3.90	0.03	1.17	1.62	0.32	3.90	3.26	2.43	2.66	ns
100 $\mu\text{A}$	6 mA	Std.	0.60	3.94	0.04	1.57	2.18	0.43	3.94	3.16	3.72	4.35	ns
		-1	0.51	3.35	0.04	1.33	1.85	0.36	3.35	2.69	3.16	3.70	ns
		-2	0.45	2.94	0.03	1.17	1.62	0.32	2.94	2.36	2.78	3.25	ns
100 $\mu\text{A}$	8 mA	Std.	0.60	3.94	0.04	1.57	2.18	0.43	3.94	3.16	3.72	4.35	ns
		-1	0.51	3.35	0.04	1.33	1.85	0.36	3.35	2.69	3.16	3.70	ns
		-2	0.45	2.94	0.03	1.17	1.62	0.32	2.94	2.36	2.78	3.25	ns

**Notes:**

1. Note that 3.3 V LVC MOS wide range is applicable to 100  $\mu\text{A}$  drive strength only. The configuration will not operate at the equivalent software default drive strength. These values are for normal ranges only.
2. For specific junction temperature and voltage supply levels, refer to [Table 2-6 on page 2-5](#) for derating values.
3. Software default selection highlighted in gray.

## 2.5 V LVCMOS

Low-Voltage CMOS for 2.5 V is an extension of the LVCMOS standard (JESD8-5) used for general-purpose 2.5 V applications.

**Table 2-38 • Minimum and Maximum DC Input and Output Levels**

2.5 V LVCMOS Drive Strength	VIL		VIH		VOL	VOH	IOL	IOH	I <sub>OSL</sub>	I <sub>OSH</sub>	I <sub>IL</sub> <sup>1</sup>	I <sub>IH</sub> <sup>2</sup>
	Min., V	Max., V	Min., V	Max., V	Max., V	Min., V	mA	mA	Max., mA <sup>3</sup>	Max., mA <sup>3</sup>	μA <sup>4</sup>	μA <sup>4</sup>
2 mA	-0.3	0.7	1.7	3.6	0.7	1.7	2	2	16	18	10	10
4 mA	-0.3	0.7	1.7	3.6	0.7	1.7	4	4	16	18	10	10
6 mA	-0.3	0.7	1.7	3.6	0.7	1.7	6	6	32	37	10	10
8 mA	-0.3	0.7	1.7	3.6	0.7	1.7	8	8	32	37	10	10

**Notes:**

1.  $I_{IL}$  is the input leakage current per I/O pin over recommended operation conditions where  $-0.3\text{ V} < V_{IN} < V_{IL}$ .
2.  $I_{IH}$  is the input leakage current per I/O pin over recommended operating conditions  $V_{IH} < V_{IN} < V_{CCI}$ . Input current is larger when operating outside recommended ranges.
3. Currents are measured at high temperature (100°C junction temperature) and maximum voltage.
4. Currents are measured at 85°C junction temperature.
5. Software default selection highlighted in gray.

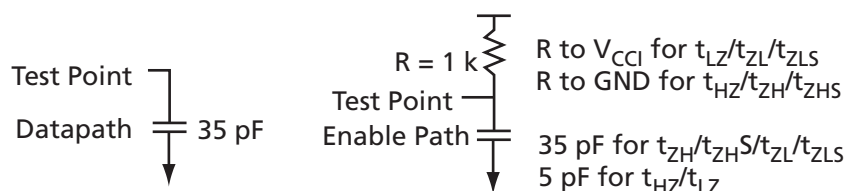

**Figure 2-7 • AC Loading**

**Table 2-39 • 2.5 V LVCMOS AC Waveforms, Measuring Points, and Capacitive Loads**

Input LOW (V)	Input HIGH (V)	Measuring Point* (V)	C <sub>LOAD</sub> (pF)
0	2.5	1.2	10

**Notes:**

1. Measuring point =  $V_{trip}$ . See [Table 2-16 on page 2-17](#) for a complete table of trip points.
2. Capacitive Load for A3PN060, A3PN125, and A3PN250 is 35 pF.

## Timing Characteristics

**Table 2-40 • 2.5 V LVCMOS Low Slew**

Commercial-Case Conditions:  $T_J = 70^\circ\text{C}$ , Worst-Case  $V_{CC} = 1.425\text{ V}$ , Worst-Case  $V_{CCI} = 2.3\text{ V}$   
 Software Default Load at 35 pF for A3PN060, A3PN125, A3PN250

Drive Strength	Speed Grade	$t_{DOUT}$	$t_{DP}$	$t_{DIN}$	$t_{PY}$	$t_{PYS}$	$t_{EOUT}$	$t_{ZL}$	$t_{ZH}$	$t_{LZ}$	$t_{HZ}$	Units
2 mA	Std.	0.60	11.29	0.04	1.43	1.63	0.43	10.64	11.29	2.27	2.29	ns
	-1	0.51	9.61	0.04	1.22	1.39	0.36	9.05	9.61	1.93	1.95	ns
	-2	0.45	8.43	0.03	1.07	1.22	0.32	7.94	8.43	1.70	1.71	ns
4 mA	Std.	0.60	11.29	0.04	1.43	1.63	0.43	10.64	11.29	2.27	2.29	ns
	-1	0.51	9.61	0.04	1.22	1.39	0.36	9.05	9.61	1.93	1.95	ns
	-2	0.45	8.43	0.03	1.07	1.22	0.32	7.94	8.43	1.70	1.71	ns
6 mA	Std.	0.60	7.73	0.04	1.43	1.63	0.43	7.70	7.73	2.60	2.89	ns
	-1	0.51	6.57	0.04	1.22	1.39	0.36	6.55	6.57	2.21	2.46	ns
	-2	0.45	5.77	0.03	1.07	1.22	0.32	5.75	5.77	1.94	2.16	ns
8 mA	Std.	0.60	7.73	0.04	1.43	1.63	0.43	7.70	7.73	2.60	2.89	ns
	-1	0.51	6.57	0.04	1.22	1.39	0.36	6.55	6.57	2.21	2.46	ns
	-2	0.45	5.77	0.03	1.07	1.22	0.32	5.75	5.77	1.94	2.16	ns

Note: For specific junction temperature and voltage supply levels, refer to Table 2-6 on page 2-5 for derating values.

**Table 2-41 • 2.5 V LVCMOS High Slew**

Commercial-Case Conditions:  $T_J = 70^\circ\text{C}$ , Worst-Case  $V_{CC} = 1.425\text{ V}$ , Worst-Case  $V_{CCI} = 2.3\text{ V}$   
 Software Default Load at 35 pF for A3PN060, A3PN125, A3PN250

Drive Strength	Speed Grade	$t_{DOUT}$	$t_{DP}$	$t_{DIN}$	$t_{PY}$	$t_{PYS}$	$t_{EOUT}$	$t_{ZL}$	$t_{ZH}$	$t_{LZ}$	$t_{HZ}$	Units
2 mA	Std.	0.60	8.38	0.04	1.43	1.63	0.43	7.36	8.38	2.27	2.37	ns
	-1	0.51	7.13	0.04	1.22	1.39	0.36	6.26	7.13	1.93	2.02	ns
	-2	0.45	6.26	0.03	1.07	1.22	0.32	5.50	6.26	1.69	1.77	ns
4 mA	Std.	0.60	8.38	0.04	1.43	1.63	0.43	7.36	8.38	2.27	2.37	ns
	-1	0.51	7.13	0.04	1.22	1.39	0.36	6.26	7.13	1.93	2.02	ns
	-2	0.45	6.26	0.03	1.07	1.22	0.32	5.50	6.26	1.69	1.77	ns
6 mA	Std.	0.60	4.94	0.04	1.43	1.63	0.43	4.71	4.94	2.60	2.98	ns
	-1	0.51	4.20	0.04	1.22	1.39	0.36	4.01	4.20	2.21	2.54	ns
	-2	0.45	3.69	0.03	1.07	1.22	0.32	3.52	3.69	1.94	2.23	ns
8 mA	Std.	0.60	4.94	0.04	1.43	1.63	0.43	4.71	4.94	2.60	2.98	ns
	-1	0.51	4.20	0.04	1.22	1.39	0.36	4.01	4.20	2.21	2.54	ns
	-2	0.45	3.69	0.03	1.07	1.22	0.32	3.52	3.69	1.94	2.23	ns

Notes:

1. Software default selection highlighted in gray.
2. For specific junction temperature and voltage supply levels, refer to Table 2-6 on page 2-5 for derating values.

**Table 2-42 • 2.5 V LVC MOS Low Slew**

Commercial-Case Conditions:  $T_J = 70^\circ\text{C}$ , Worst-Case VCC = 1.425 V, Worst-Case VCCI = 2.3 V  
 Software Default Load at 10 pF for A3PN020, A3PN015, A3PN010

Drive Strength	Speed Grade	$t_{DOUT}$	$t_{DP}$	$t_{DIN}$	$t_{PY}$	$t_{PYS}$	$t_{EOUT}$	$t_{ZL}$	$t_{ZH}$	$t_{LZ}$	$t_{HZ}$	Units
2 mA	Std.	0.60	6.40	0.04	1.43	1.63	0.43	6.16	6.40	2.27	2.29	ns
	-1	0.51	5.45	0.04	1.22	1.39	0.36	5.24	5.45	1.93	1.95	ns
	-2	0.45	4.78	0.03	1.07	1.22	0.32	4.60	4.78	1.70	1.71	ns
4 mA	Std.	0.60	6.40	0.04	1.43	1.63	0.43	6.16	6.40	2.27	2.29	ns
	-1	0.51	5.45	0.04	1.22	1.39	0.36	5.24	5.45	1.93	1.95	ns
	-2	0.45	4.78	0.03	1.07	1.22	0.32	4.60	4.78	1.70	1.71	ns
6 mA	Std.	0.60	5.00	0.04	1.43	1.63	0.43	4.90	5.00	2.60	2.89	ns
	-1	0.51	4.26	0.04	1.22	1.39	0.36	4.17	4.26	2.21	2.46	ns
	-2	0.45	3.74	0.03	1.07	1.22	0.32	3.66	3.74	1.94	2.16	ns
8 mA	Std.	0.60	5.00	0.04	1.43	1.63	0.43	4.90	5.00	2.60	2.89	ns
	-1	0.51	4.26	0.04	1.22	1.39	0.36	4.17	4.26	2.21	2.46	ns
	-2	0.45	3.74	0.03	1.07	1.22	0.32	3.66	3.74	1.94	2.16	ns

Note: For specific junction temperature and voltage supply levels, refer to Table 2-6 on page 2-5 for derating values.

**Table 2-43 • 2.5 V LVC MOS High Slew**

Commercial-Case Conditions:  $T_J = 70^\circ\text{C}$ , Worst-Case VCC = 1.425 V, Worst-Case VCCI = 2.3 V  
 Software Default Load at 10 pF for A3PN020, A3PN015, A3PN010

Drive Strength	Speed Grade	$t_{DOUT}$	$t_{DP}$	$t_{DIN}$	$t_{PY}$	$t_{PYS}$	$t_{EOUT}$	$t_{ZL}$	$t_{ZH}$	$t_{LZ}$	$t_{HZ}$	Units
2 mA	Std.	0.60	3.70	0.04	1.43	1.63	0.43	3.66	3.70	2.27	2.37	ns
	-1	0.51	3.15	0.04	1.22	1.39	0.36	3.12	3.15	1.93	2.02	ns
	-2	0.45	2.77	0.03	1.07	1.22	0.32	2.74	2.77	1.69	1.77	ns
4 mA	Std.	0.60	3.70	0.04	1.43	1.63	0.43	3.66	3.70	2.27	2.37	ns
	-1	0.51	3.15	0.04	1.22	1.39	0.36	3.12	3.15	1.93	2.02	ns
	-2	0.45	2.77	0.03	1.07	1.22	0.32	2.74	2.77	1.69	1.77	ns
6 mA	Std.	0.60	2.76	0.04	1.43	1.63	0.43	2.80	2.60	2.60	2.98	ns
	-1	0.51	2.35	0.04	1.22	1.39	0.36	2.38	2.21	2.21	2.54	ns
	-2	0.45	2.06	0.03	1.07	1.22	0.32	2.09	1.94	1.94	2.23	ns
8 mA	Std.	0.60	2.76	0.04	1.43	1.63	0.43	2.80	2.60	2.60	2.98	ns
	-1	0.51	2.35	0.04	1.22	1.39	0.36	2.38	2.21	2.21	2.54	ns
	-2	0.45	2.06	0.03	1.07	1.22	0.32	2.09	1.94	1.94	2.23	ns

Notes:

1. Software default selection highlighted in gray.
2. For specific junction temperature and voltage supply levels, refer to Table 2-6 on page 2-5 for derating values.

## 1.8 V LVCMOS

Low-voltage CMOS for 1.8 V is an extension of the LVCMOS standard (JESD8-5) used for general-purpose 1.8 V applications. It uses a 1.8 V input buffer and a push-pull output buffer.

**Table 2-44 • Minimum and Maximum DC Input and Output Levels**

1.8 V LVCMOS	VIL		VIH		VOL	VOH	I <sub>OL</sub>	I <sub>OH</sub>	I <sub>OSL</sub>	I <sub>OSH</sub>	I <sub>IL</sub> <sup>1</sup>	I <sub>IH</sub> <sup>2</sup>
	Min. V	Max. V	Min. V	Max. V	Max. V	Min. V	mA	mA	Max. mA <sup>3</sup>	Max. mA <sup>3</sup>	μA <sup>4</sup>	μA <sup>4</sup>
2 mA	-0.3	0.35 * V <sub>CCI</sub>	0.65 * V <sub>CCI</sub>	3.6	0.45	V <sub>CCI</sub> - 0.45	2	2	9	11	10	10
4 mA	-0.3	0.35 * V <sub>CCI</sub>	0.65 * V <sub>CCI</sub>	3.6	0.45	V <sub>CCI</sub> - 0.45	4	4	17	22	10	10

**Notes:**

1. I<sub>IL</sub> is the input leakage current per I/O pin over recommended operation conditions where -0.3 V < V<sub>IN</sub> < V<sub>IL</sub>.
2. I<sub>IH</sub> is the input leakage current per I/O pin over recommended operating conditions V<sub>IH</sub> < V<sub>IN</sub> < V<sub>CCI</sub>. Input current is larger when operating outside recommended ranges.
3. Currents are measured at high temperature (100°C junction temperature) and maximum voltage.
4. Currents are measured at 85°C junction temperature.
5. Software default selection highlighted in gray.

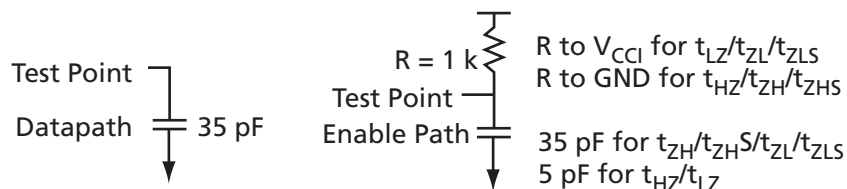

**Figure 2-8 • AC Loading**

**Table 2-45 • 1.8 V LVCMOS AC Waveforms, Measuring Points, and Capacitive Loads**

Input LOW (V)	Input HIGH (V)	Measuring Point* (V)	C <sub>LOAD</sub> (pF)
0	1.8	0.9	10

**Notes:**

1. Measuring point = V<sub>trip</sub>. See [Table 2-16 on page 2-17](#) for a complete table of trip points.
2. Capacitive Load for A3PN060, A3PN125, and A3PN250 is 35 pF.

## Timing Characteristics

Table 2-46 • 1.8 V LVCMOS Low Slew

Commercial-Case Conditions:  $T_J = 70^\circ\text{C}$ , Worst-Case  $V_{CC} = 1.425\text{ V}$ , Worst-Case  $V_{CCI} = 1.7\text{ V}$   
 Software Default Load at 35 pF for A3PN060, A3PN125, A3PN250

Drive Strength	Speed Grade	$t_{DOUT}$	$t_{DP}$	$t_{DIN}$	$t_{PY}$	$t_{PYS}$	$t_{EOUT}$	$t_{ZL}$	$t_{ZH}$	$t_{LZ}$	$t_{HZ}$	Units
2 mA	Std.	0.60	15.36	0.04	1.35	1.90	0.43	13.46	15.36	2.23	1.78	ns
	-1	0.51	13.07	0.04	1.15	1.61	0.36	11.45	13.07	1.90	1.51	ns
	-2	0.45	11.47	0.03	1.01	1.42	0.32	10.05	11.47	1.67	1.33	ns
4 mA	Std.	0.60	10.32	0.04	1.35	1.90	0.43	9.92	10.32	2.63	2.78	ns
	-1	0.51	8.78	0.04	1.15	1.61	0.36	8.44	8.78	2.23	2.37	ns
	-2	0.45	7.71	0.03	1.01	1.42	0.32	7.41	7.71	1.96	2.08	ns

Note: For specific junction temperature and voltage supply levels, refer to Table 2-6 on page 2-5 for derating values.

Table 2-47 • 1.8 V LVCMOS High Slew

Commercial-Case Conditions:  $T_J = 70^\circ\text{C}$ , Worst-Case  $V_{CC} = 1.425\text{ V}$ , Worst-Case  $V_{CCI} = 1.7\text{ V}$   
 Software Default Load at 35 pF for A3PN060, A3PN125, A3PN250

Drive Strength	Speed Grade	$t_{DOUT}$	$t_{DP}$	$t_{DIN}$	$t_{PY}$	$t_{PYS}$	$t_{EOUT}$	$t_{ZL}$	$t_{ZH}$	$t_{LZ}$	$t_{HZ}$	Units
2 mA	Std.	0.60	11.42	0.04	1.35	1.90	0.43	8.65	11.42	2.23	1.84	ns
	-1	0.51	9.71	0.04	1.15	1.61	0.36	7.36	9.71	1.89	1.57	ns
	-2	0.45	8.53	0.03	1.01	1.42	0.32	6.46	8.53	1.66	1.37	ns
4 mA	Std.	0.60	6.53	0.04	1.35	1.90	0.43	5.53	6.53	2.62	2.89	ns
	-1	0.51	5.56	0.04	1.15	1.61	0.36	4.70	5.56	2.23	2.45	ns
	-2	0.45	4.88	0.03	1.01	1.42	0.32	4.13	4.88	1.96	2.15	ns

## Notes:

1. Software default selection highlighted in gray.
2. For specific junction temperature and voltage supply levels, refer to Table 2-6 on page 2-5 for derating values.

**Table 2-48 • 1.8 V LVC MOS Low Slew**

Commercial-Case Conditions:  $T_J = 70^\circ\text{C}$ , Worst-Case VCC = 1.425 V, Worst-Case VCCI = 1.7 V  
 Software Default Load at 10 pF for A3PN020, A3PN015, A3PN010

Drive Strength	Speed Grade	$t_{DOUT}$	$t_{DP}$	$t_{DIN}$	$t_{PY}$	$t_{PYS}$	$t_{EOUT}$	$t_{ZL}$	$t_{ZH}$	$t_{LZ}$	$t_{HZ}$	Units
2 mA	Std.	0.60	8.52	0.04	1.35	1.90	0.43	7.99	8.52	2.23	1.78	ns
	-1	0.51	7.25	0.04	1.15	1.61	0.36	6.80	7.25	1.90	1.51	ns
	-2	0.45	6.36	0.03	1.01	1.42	0.32	5.97	6.36	1.67	1.33	ns
4 mA	Std.	0.60	6.59	0.04	1.35	1.90	0.43	6.44	6.59	2.63	2.78	ns
	-1	0.51	5.60	0.04	1.15	1.61	0.36	5.48	5.60	2.23	2.37	ns
	-2	0.45	4.92	0.03	1.01	1.42	0.32	4.81	4.92	1.96	2.08	ns

*Note:* For specific junction temperature and voltage supply levels, refer to [Table 2-6 on page 2-5](#) for derating values.

**Table 2-49 • 1.8 V LVC MOS High Slew**

Commercial-Case Conditions:  $T_J = 70^\circ\text{C}$ , Worst-Case VCC = 1.425 V, Worst-Case VCCI = 1.7 V  
 Software Default Load at 10 pF for A3PN020, A3PN015, A3PN010

Drive Strength	Speed Grade	$t_{DOUT}$	$t_{DP}$	$t_{DIN}$	$t_{PY}$	$t_{PYS}$	$t_{EOUT}$	$t_{ZL}$	$t_{ZH}$	$t_{LZ}$	$t_{HZ}$	Units
2 mA	Std.	0.60	4.79	0.04	1.35	1.90	0.43	4.27	4.79	2.23	1.84	ns
	-1	0.51	4.08	0.04	1.15	1.61	0.36	3.63	4.08	1.89	1.57	ns
	-2	0.45	3.58	0.03	1.01	1.42	0.32	3.19	3.58	1.66	1.37	ns
4 mA	Std.	0.60	3.22	0.04	1.35	1.90	0.43	3.24	3.22	2.62	2.89	ns
	-1	0.51	2.74	0.04	1.15	1.61	0.36	2.75	2.74	2.23	2.45	ns
	-2	0.45	2.40	0.03	1.01	1.42	0.32	2.42	2.40	1.95	2.15	ns

*Notes:*

1. Software default selection highlighted in gray.
2. For specific junction temperature and voltage supply levels, refer to [Table 2-6 on page 2-5](#) for derating values.

### 1.5 V LVCMOS (JESD8-11)

Low-Voltage CMOS for 1.5 V is an extension of the LVCMOS standard (JESD8-5) used for general-purpose 1.5 V applications. It uses a 1.5 V input buffer and a push-pull output buffer.

**Table 2-50 • Minimum and Maximum DC Input and Output Levels**

1.5 V LVCMOS	VIL		VIH		VOL	VOH	I <sub>OL</sub>	I <sub>OH</sub>	I <sub>OSL</sub>	I <sub>OSH</sub>	I <sub>IL</sub> <sup>1</sup>	I <sub>IH</sub> <sup>2</sup>
	Min. V	Max. V	Min. V	Max. V	Max. V	Min. V	mA	mA	Max. mA <sup>3</sup>	Max. mA <sup>3</sup>	μA <sup>4</sup>	μA <sup>4</sup>
2 mA	-0.3	0.35 * VCCI	0.65 * VCCI	3.6	0.25 * VCCI	0.75 * VCCI	2	2	13	16	10	10

Notes:

1.  $I_{IL}$  is the input leakage current per I/O pin over recommended operation conditions where  $-0.3\text{ V} < V_{IN} < V_{IL}$ .
2.  $I_{IH}$  is the input leakage current per I/O pin over recommended operating conditions  $V_{IH} < V_{IN} < V_{CCI}$ . Input current is larger when operating outside recommended ranges.
3. Currents are measured at high temperature (100°C junction temperature) and maximum voltage.
4. Currents are measured at 85°C junction temperature.
5. Software default selection highlighted in gray.

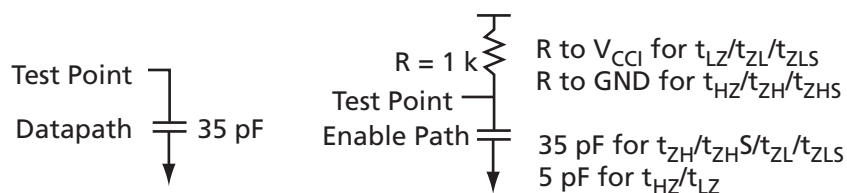

**Figure 2-9 • AC Loading**

**Table 2-51 • 1.5 V LVCMOS AC Waveforms, Measuring Points, and Capacitive Loads**

Input LOW (V)	Input HIGH (V)	Measuring Point* (V)	C <sub>LOAD</sub> (pF)
0	1.5	0.75	10

Notes:

1. Measuring point =  $V_{trip}$ . See [Table 2-16 on page 2-17](#) for a complete table of trip points.
2. Capacitive Load for A3PN060, A3PN125, and A3PN250 is 35 pF.

## Timing Characteristics

**Table 2-52 • 1.5 V LVCMOS Low Slew**

Commercial-Case Conditions:  $T_J = 70^\circ\text{C}$ , Worst-Case VCC = 1.425 V, Worst-Case VCCI = 1.4 V  
 Software Default Load at 35 pF for A3PN060, A3PN125, A3PN250

Drive Strength	Speed Grade	$t_{DOUT}$	$t_{DP}$	$t_{DIN}$	$t_{PY}$	$t_{PYS}$	$t_{EOUT}$	$t_{ZL}$	$t_{ZH}$	$t_{LZ}$	$t_{HZ}$	Units
2 mA	Std.	0.60	12.58	0.04	1.56	2.14	0.43	12.18	12.58	2.67	2.71	ns
	-1	0.51	10.70	0.04	1.32	1.82	0.36	10.36	10.70	2.27	2.31	ns
	-2	0.45	9.39	0.03	1.16	1.59	0.32	9.09	9.39	1.99	2.03	ns

Note: For specific junction temperature and voltage supply levels, refer to Table 2-6 on page 2-5 for derating values.

**Table 2-53 • 1.5 V LVCMOS High Slew**

Commercial-Case Conditions:  $T_J = 70^\circ\text{C}$ , Worst-Case VCC = 1.425 V, Worst-Case VCCI = 1.4 V  
 Software Default Load at 35 pF for A3PN060, A3PN125, A3PN250

Drive Strength	Speed Grade	$t_{DOUT}$	$t_{DP}$	$t_{DIN}$	$t_{PY}$	$t_{PYS}$	$t_{EOUT}$	$t_{ZL}$	$t_{ZH}$	$t_{LZ}$	$t_{HZ}$	Units
2 mA	Std.	0.60	7.86	0.04	1.56	2.14	0.43	6.45	7.86	2.66	2.83	ns
	-1	0.51	6.68	0.04	1.32	1.82	0.36	5.49	6.68	2.26	2.41	ns
	-2	0.45	5.87	0.03	1.16	1.59	0.32	4.82	5.87	1.99	2.12	ns

Notes:

1. Software default selection highlighted in gray.
2. For specific junction temperature and voltage supply levels, refer to Table 2-6 on page 2-5 for derating values.

**Table 2-54 • 1.5 V LVCMOS Low Slew**

Commercial-Case Conditions:  $T_J = 70^\circ\text{C}$ , Worst-Case VCC = 1.425 V, Worst-Case VCCI = 1.4 V  
 Software Default Load at 10 pF for A3PN020, A3PN015, A3PN010

Drive Strength	Speed Grade	$t_{DOUT}$	$t_{DP}$	$t_{DIN}$	$t_{PY}$	$t_{PYS}$	$t_{EOUT}$	$t_{ZL}$	$t_{ZH}$	$t_{LZ}$	$t_{HZ}$	Units
2 mA	Std.	0.60	8.01	0.04	1.56	2.14	0.43	8.03	8.01	2.67	2.71	ns
	-1	0.51	6.81	0.04	1.32	1.82	0.36	6.83	6.81	2.27	2.31	ns
	-2	0.45	5.98	0.03	1.16	1.58	0.32	6.00	5.98	2.10	2.03	ns

Note: For specific junction temperature and voltage supply levels, refer to Table 2-6 on page 2-5 for derating values.

**Table 2-55 • 1.5 V LVCMOS High Slew**

Commercial-Case Conditions:  $T_J = 70^\circ\text{C}$ , Worst-Case VCC = 1.425 V, Worst-Case VCCI = 1.4 V  
 Software Default Load at 10 pF for A3PN020, A3PN015, A3PN010

Drive Strength	Speed Grade	$t_{DOUT}$	$t_{DP}$	$t_{DIN}$	$t_{PY}$	$t_{PYS}$	$t_{EOUT}$	$t_{ZL}$	$t_{ZH}$	$t_{LZ}$	$t_{HZ}$	Units
2 mA	Std.	0.60	3.76	0.04	1.52	2.14	0.43	3.74	3.76	2.66	2.83	ns
	-1	0.51	3.20	0.04	1.32	1.82	0.36	3.18	3.20	2.26	2.41	ns
	-2	0.45	2.81	0.03	1.16	1.59	0.32	2.79	2.81	1.99	2.12	ns

Notes:

1. Software default selection highlighted in gray.
2. For specific junction temperature and voltage supply levels, refer to Table 2-6 on page 2-5 for derating values.

## I/O Register Specifications

### Fully Registered I/O Buffers with Synchronous Enable and Asynchronous Preset

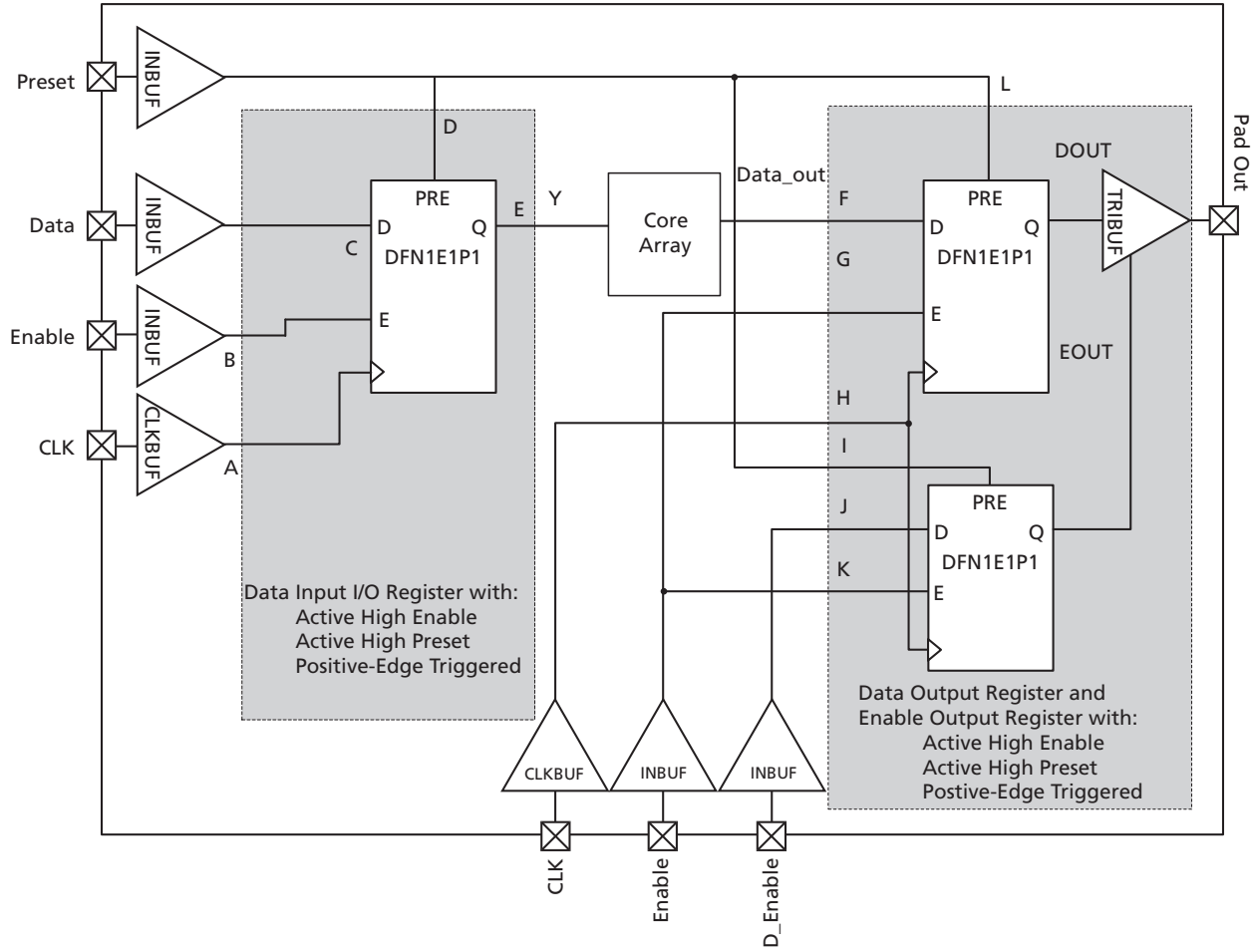

Figure 2-10 • Timing Model of Registered I/O Buffers with Synchronous Enable and Asynchronous Preset

Table 2-56 • Parameter Definition and Measuring Nodes

Parameter Name	Parameter Definition	Measuring Nodes (from, to)*
$t_{OCLKQ}$	Clock-to-Q of the Output Data Register	H, DOUT
$t_{OSUD}$	Data Setup Time for the Output Data Register	F, H
$t_{OHD}$	Data Hold Time for the Output Data Register	F, H
$t_{OSUE}$	Enable Setup Time for the Output Data Register	G, H
$t_{OHE}$	Enable Hold Time for the Output Data Register	G, H
$t_{OPRE2Q}$	Asynchronous Preset-to-Q of the Output Data Register	L, DOUT
$t_{OREMPRE}$	Asynchronous Preset Removal Time for the Output Data Register	L, H
$t_{ORECPRE}$	Asynchronous Preset Recovery Time for the Output Data Register	L, H
$t_{OECLKQ}$	Clock-to-Q of the Output Enable Register	H, EOUT
$t_{OESUD}$	Data Setup Time for the Output Enable Register	J, H
$t_{OEHD}$	Data Hold Time for the Output Enable Register	J, H
$t_{OESUE}$	Enable Setup Time for the Output Enable Register	K, H
$t_{OEHE}$	Enable Hold Time for the Output Enable Register	K, H
$t_{OEPRE2Q}$	Asynchronous Preset-to-Q of the Output Enable Register	I, EOUT
$t_{OEREMPRE}$	Asynchronous Preset Removal Time for the Output Enable Register	I, H
$t_{OERECPRE}$	Asynchronous Preset Recovery Time for the Output Enable Register	I, H
$t_{ICLKQ}$	Clock-to-Q of the Input Data Register	A, E
$t_{ISUD}$	Data Setup Time for the Input Data Register	C, A
$t_{IHD}$	Data Hold Time for the Input Data Register	C, A
$t_{ISUE}$	Enable Setup Time for the Input Data Register	B, A
$t_{IHE}$	Enable Hold Time for the Input Data Register	B, A
$t_{IPRE2Q}$	Asynchronous Preset-to-Q of the Input Data Register	D, E
$t_{IREMPRE}$	Asynchronous Preset Removal Time for the Input Data Register	D, A
$t_{IRECPRE}$	Asynchronous Preset Recovery Time for the Input Data Register	D, A

\* See Figure 2-10 on page 2-38 for more information.

### Fully Registered I/O Buffers with Synchronous Enable and Asynchronous Clear

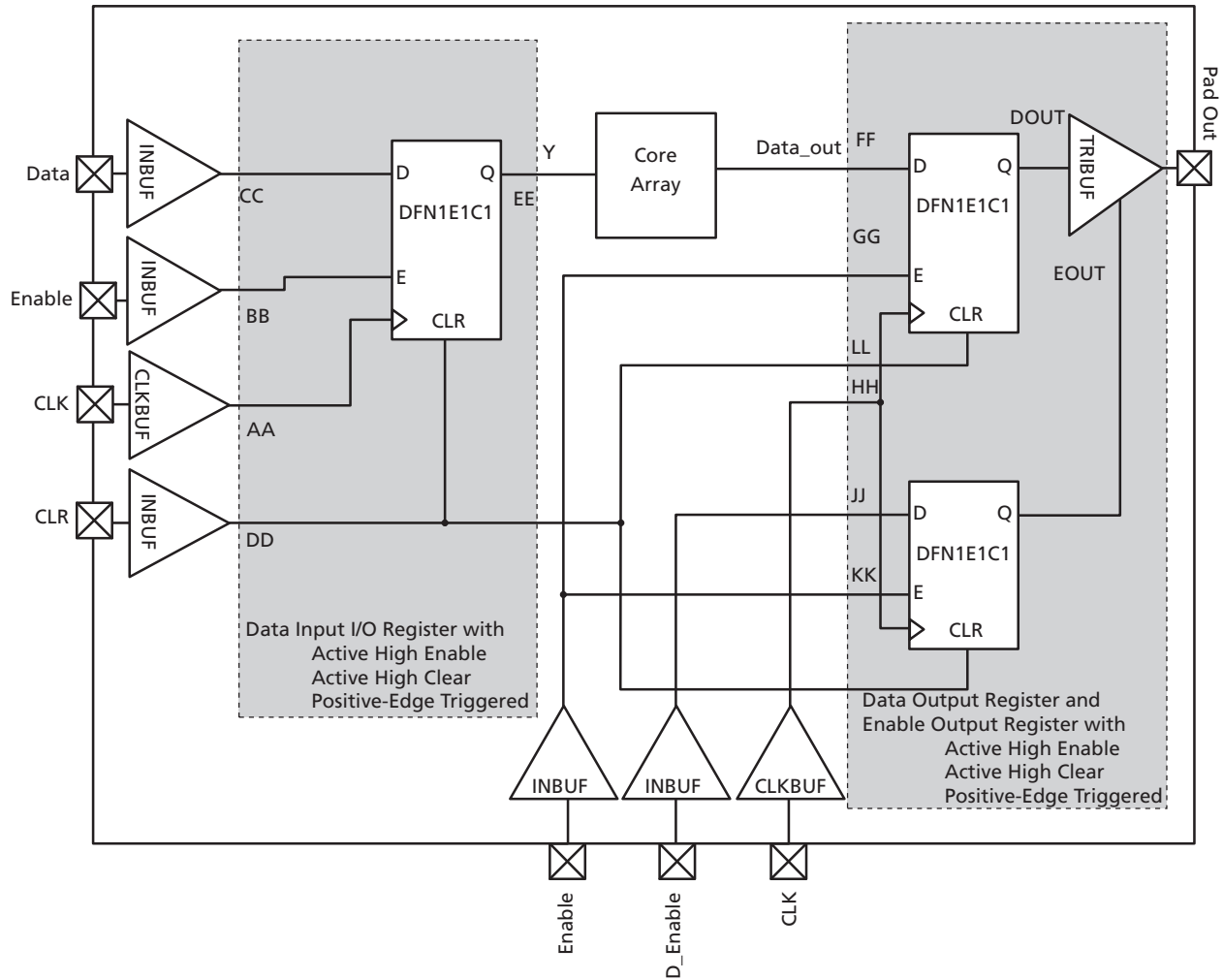

Figure 2-11 • Timing Model of the Registered I/O Buffers with Synchronous Enable and Asynchronous Clear

Table 2-57 • Parameter Definition and Measuring Nodes

Parameter Name	Parameter Definition	Measuring Nodes (from, to)*
$t_{OCLKQ}$	Clock-to-Q of the Output Data Register	HH, DOUT
$t_{OSUD}$	Data Setup Time for the Output Data Register	FF, HH
$t_{OHD}$	Data Hold Time for the Output Data Register	FF, HH
$t_{OSUE}$	Enable Setup Time for the Output Data Register	GG, HH
$t_{OHE}$	Enable Hold Time for the Output Data Register	GG, HH
$t_{OCLR2Q}$	Asynchronous Clear-to-Q of the Output Data Register	LL, DOUT
$t_{OREMCLR}$	Asynchronous Clear Removal Time for the Output Data Register	LL, HH
$t_{ORECCLR}$	Asynchronous Clear Recovery Time for the Output Data Register	LL, HH
$t_{OECLKQ}$	Clock-to-Q of the Output Enable Register	HH, EOUT
$t_{OESUD}$	Data Setup Time for the Output Enable Register	JJ, HH
$t_{OEHD}$	Data Hold Time for the Output Enable Register	JJ, HH
$t_{OESUE}$	Enable Setup Time for the Output Enable Register	KK, HH
$t_{OEHE}$	Enable Hold Time for the Output Enable Register	KK, HH
$t_{OECLR2Q}$	Asynchronous Clear-to-Q of the Output Enable Register	II, EOUT
$t_{OEREMCLR}$	Asynchronous Clear Removal Time for the Output Enable Register	II, HH
$t_{OERECCLR}$	Asynchronous Clear Recovery Time for the Output Enable Register	II, HH
$t_{ICLKQ}$	Clock-to-Q of the Input Data Register	AA, EE
$t_{ISUD}$	Data Setup Time for the Input Data Register	CC, AA
$t_{IHD}$	Data Hold Time for the Input Data Register	CC, AA
$t_{ISUE}$	Enable Setup Time for the Input Data Register	BB, AA
$t_{IHE}$	Enable Hold Time for the Input Data Register	BB, AA
$t_{ICLR2Q}$	Asynchronous Clear-to-Q of the Input Data Register	DD, EE
$t_{IREMCLR}$	Asynchronous Clear Removal Time for the Input Data Register	DD, AA
$t_{IRECCLR}$	Asynchronous Clear Recovery Time for the Input Data Register	DD, AA

\* See Figure 2-11 on page 2-40 for more information.

## Input Register

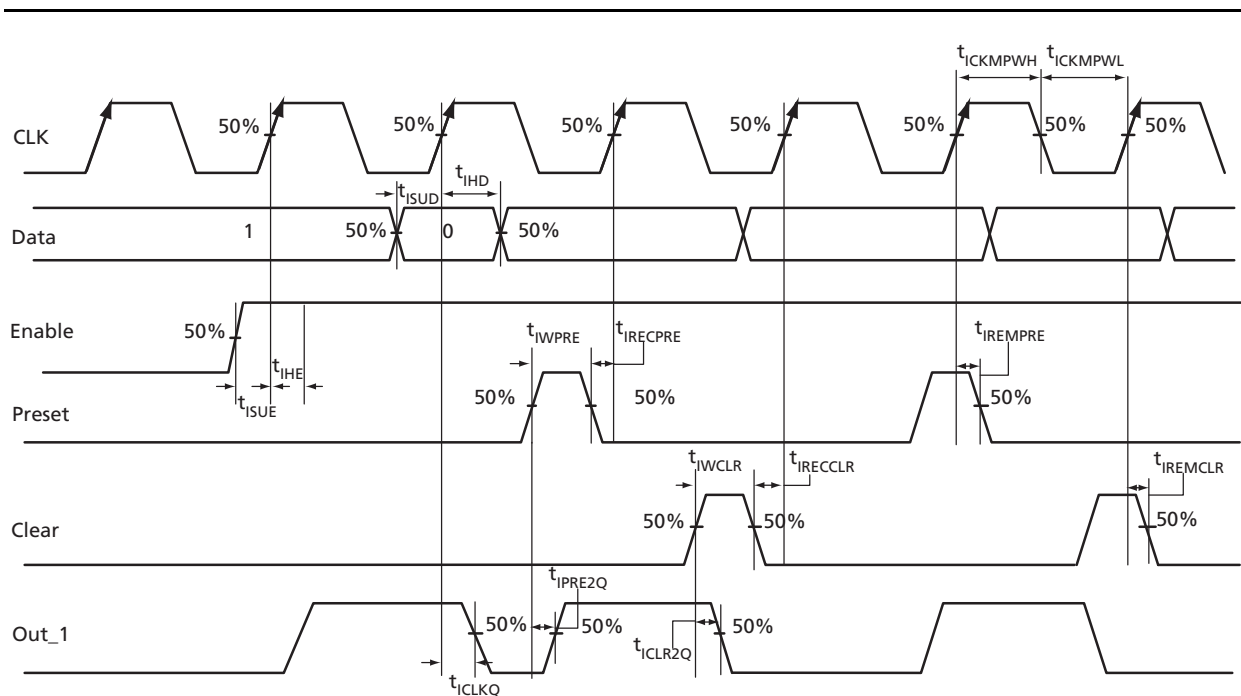

Figure 2-12 • Input Register Timing Diagram

### Timing Characteristics

Table 2-58 • Input Data Register Propagation Delays

Commercial-Case Conditions:  $T_J = 70^\circ\text{C}$ , Worst-Case  $V_{CC} = 1.425\text{ V}$

Parameter	Description	-2	-1	Std.	Units
$t_{ICLKQ}$	Clock-to-Q of the Input Data Register	0.24	0.27	0.32	ns
$t_{ISUD}$	Data Setup Time for the Input Data Register	0.26	0.30	0.35	ns
$t_{IHD}$	Data Hold Time for the Input Data Register	0.00	0.00	0.00	ns
$t_{ICLR2Q}$	Asynchronous Clear-to-Q of the Input Data Register	0.45	0.52	0.61	ns
$t_{IPRE2Q}$	Asynchronous Preset-to-Q of the Input Data Register	0.45	0.52	0.61	ns
$t_{IREMCLR}$	Asynchronous Clear Removal Time for the Input Data Register	0.00	0.00	0.00	ns
$t_{IRECCLR}$	Asynchronous Clear Recovery Time for the Input Data Register	0.22	0.25	0.30	ns
$t_{IREMPRE}$	Asynchronous Preset Removal Time for the Input Data Register	0.00	0.00	0.00	ns
$t_{IRECPRE}$	Asynchronous Preset Recovery Time for the Input Data Register	0.22	0.25	0.30	ns
$t_{IWCLR}$	Asynchronous Clear Minimum Pulse Width for the Input Data Register	0.22	0.25	0.30	ns
$t_{IWPRE}$	Asynchronous Preset Minimum Pulse Width for the Input Data Register	0.22	0.25	0.30	ns
$t_{ICKMPWH}$	Clock Minimum Pulse Width HIGH for the Input Data Register	0.36	0.41	0.48	ns
$t_{ICKMPWL}$	Clock Minimum Pulse Width LOW for the Input Data Register	0.32	0.37	0.43	ns

Note: For specific junction temperature and voltage supply levels, refer to Table 2-6 on page 2-5 for derating values.

## Output Register

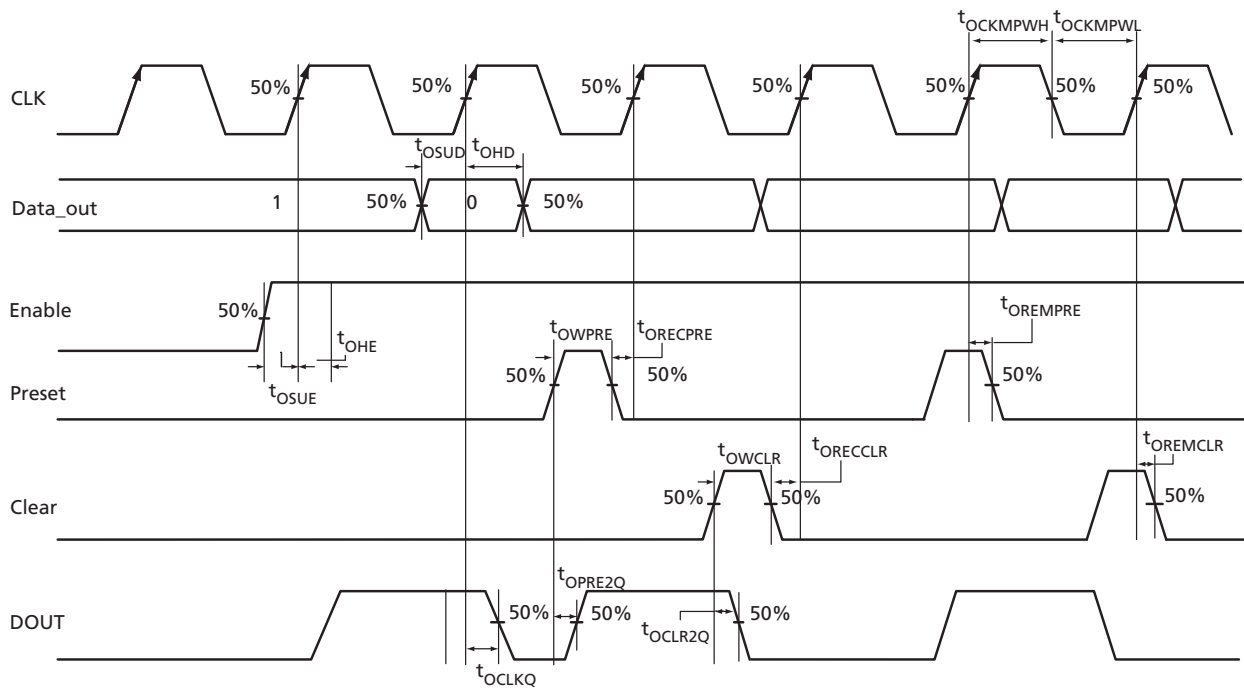

Figure 2-13 • Output Register Timing Diagram

### Timing Characteristics

Table 2-59 • Output Data Register Propagation Delays  
Commercial-Case Conditions:  $T_J = 70^\circ\text{C}$ , Worst-Case  $V_{CC} = 1.425\text{ V}$

Parameter	Description	-2	-1	Std.	Units
$t_{OCLKQ}$	Clock-to-Q of the Output Data Register	0.59	0.67	0.79	ns
$t_{OSUD}$	Data Setup Time for the Output Data Register	0.31	0.36	0.42	ns
$t_{OHD}$	Data Hold Time for the Output Data Register	0.00	0.00	0.00	ns
$t_{OCLR2Q}$	Asynchronous Clear-to-Q of the Output Data Register	0.80	0.91	1.07	ns
$t_{OPRE2Q}$	Asynchronous Preset-to-Q of the Output Data Register	0.80	0.91	1.07	ns
$t_{OREMCLR}$	Asynchronous Clear Removal Time for the Output Data Register	0.00	0.00	0.00	ns
$t_{ORECCLR}$	Asynchronous Clear Recovery Time for the Output Data Register	0.22	0.25	0.30	ns
$t_{OREMPRE}$	Asynchronous Preset Removal Time for the Output Data Register	0.00	0.00	0.00	ns
$t_{ORECPRE}$	Asynchronous Preset Recovery Time for the Output Data Register	0.22	0.25	0.30	ns
$t_{OWCLR}$	Asynchronous Clear Minimum Pulse Width for the Output Data Register	0.22	0.25	0.30	ns
$t_{OWPRE}$	Asynchronous Preset Minimum Pulse Width for the Output Data Register	0.22	0.25	0.30	ns
$t_{OCLKMPWH}$	Clock Minimum Pulse Width HIGH for the Output Data Register	0.36	0.41	0.48	ns
$t_{OCLKMPWL}$	Clock Minimum Pulse Width LOW for the Output Data Register	0.32	0.37	0.43	ns

Note: For specific junction temperature and voltage supply levels, refer to Table 2-6 on page 2-5 for derating values.

## Output Enable Register

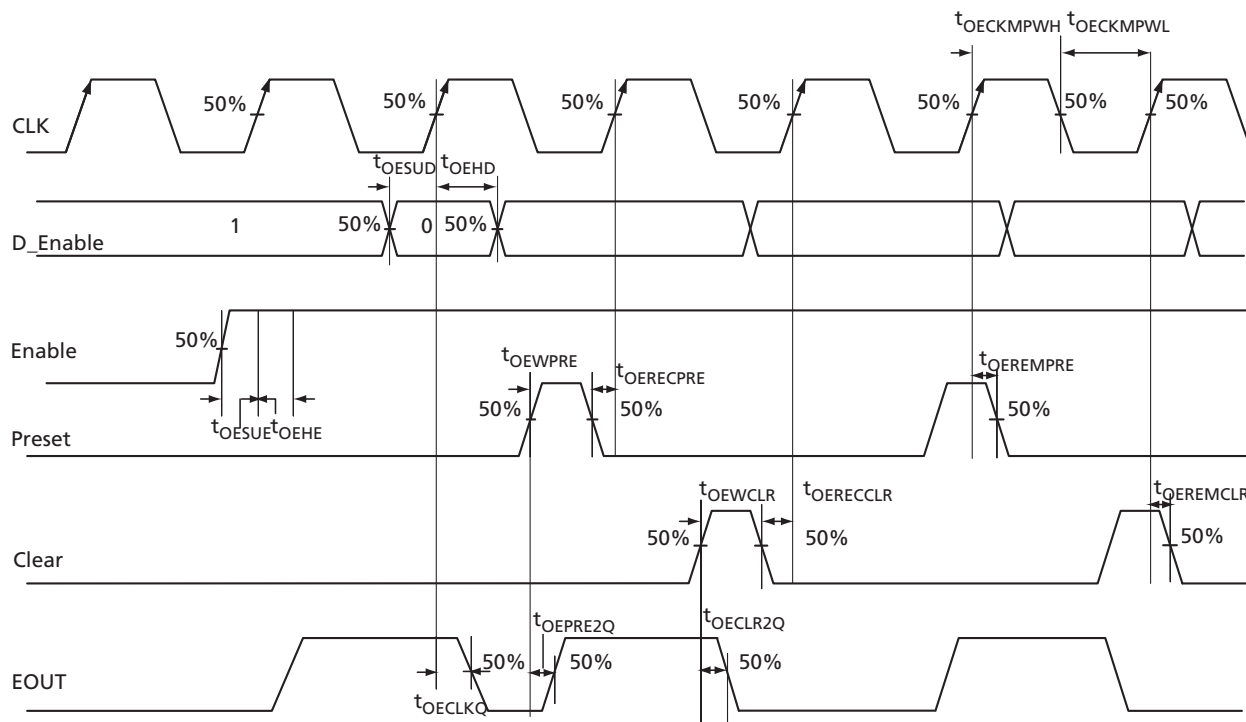

Figure 2-14 • Output Enable Register Timing Diagram

### Timing Characteristics

Table 2-60 • Output Enable Register Propagation Delays  
Commercial-Case Conditions:  $T_j = 70^\circ\text{C}$ , Worst-Case  $V_{CC} = 1.425\text{ V}$

Parameter	Description	-2	-1	Std.	Units
$t_{OECLKQ}$	Clock-to-Q of the Output Enable Register	0.44	0.51	0.59	ns
$t_{OESUD}$	Data Setup Time for the Output Enable Register	0.31	0.36	0.42	ns
$t_{OEHD}$	Data Hold Time for the Output Enable Register	0.00	0.00	0.00	ns
$t_{OECLR2Q}$	Asynchronous Clear-to-Q of the Output Enable Register	0.67	0.76	0.89	ns
$t_{OEPRE2Q}$	Asynchronous Preset-to-Q of the Output Enable Register	0.67	0.76	0.89	ns
$t_{OEREMCLR}$	Asynchronous Clear Removal Time for the Output Enable Register	0.00	0.00	0.00	ns
$t_{OERECCLR}$	Asynchronous Clear Recovery Time for the Output Enable Register	0.22	0.25	0.30	ns
$t_{OEREMPRE}$	Asynchronous Preset Removal Time for the Output Enable Register	0.00	0.00	0.00	ns
$t_{OERECPRE}$	Asynchronous Preset Recovery Time for the Output Enable Register	0.22	0.25	0.30	ns
$t_{OEWCCLR}$	Asynchronous Clear Minimum Pulse Width for the Output Enable Register	0.22	0.25	0.30	ns
$t_{OEWPRES}$	Asynchronous Preset Minimum Pulse Width for the Output Enable Register	0.22	0.25	0.30	ns
$t_{OECKMPWH}$	Clock Minimum Pulse Width HIGH for the Output Enable Register	0.36	0.41	0.48	ns
$t_{OECKMPWL}$	Clock Minimum Pulse Width LOW for the Output Enable Register	0.32	0.37	0.43	ns

Note: For specific junction temperature and voltage supply levels, refer to Table 2-6 on page 2-5 for derating values.

## DDR Module Specifications

### Input DDR Module

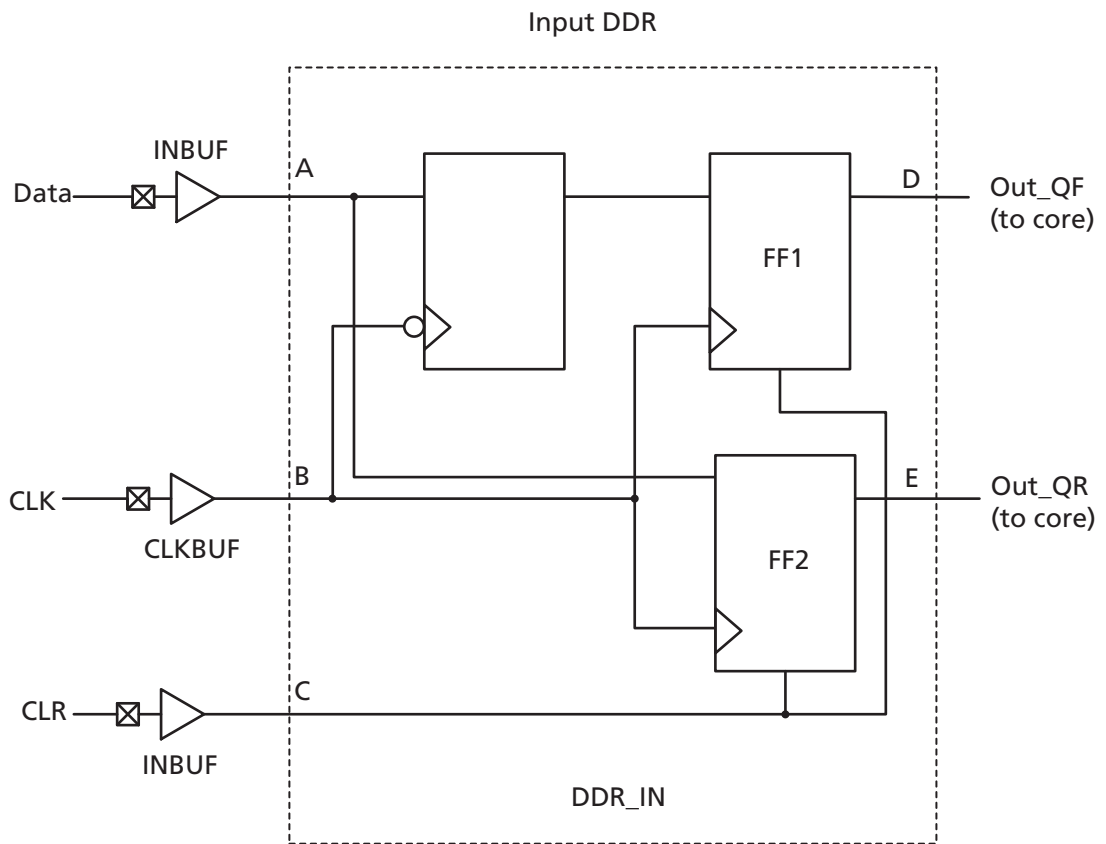
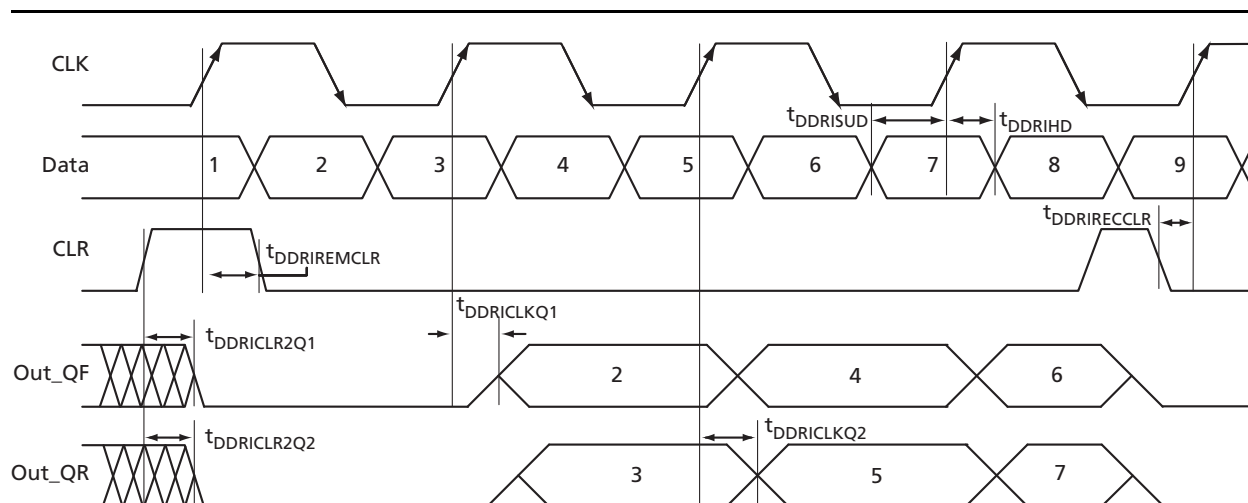

Figure 2-15 • Input DDR Timing Model

Table 2-61 • Parameter Definitions

Parameter Name	Parameter Definition	Measuring Nodes (from, to)
$t_{DDRICKQ1}$	Clock-to-Out Out_QR	B, D
$t_{DDRICKQ2}$	Clock-to-Out Out_QF	B, E
$t_{DDRISUD}$	Data Setup Time of DDR input	A, B
$t_{DDRIHD}$	Data Hold Time of DDR input	A, B
$t_{DDRICLR2Q1}$	Clear-to-Out Out_QR	C, D
$t_{DDRICLR2Q2}$	Clear-to-Out Out_QF	C, E
$t_{DDRIREMCLR}$	Clear Removal	C, B
$t_{DDRIRECCLR}$	Clear Recovery	C, B

**Figure 2-16 • Input DDR Timing Diagram**

### Timing Characteristics

**Table 2-62 • Input DDR Propagation Delays**

 Commercial-Case Conditions:  $T_J = 70^{\circ}\text{C}$ , Worst Case  $V_{CC} = 1.425\text{ V}$ 

Parameter	Description	-2	-1	Std.	Units
$t_{\text{DDRICKQ1}}$	Clock-to-Out Out_QR for Input DDR	0.27	0.31	0.37	ns
$t_{\text{DDRICKQ2}}$	Clock-to-Out Out_QF for Input DDR	0.39	0.44	0.52	ns
$t_{\text{DDRISUD}}$	Data Setup for Input DDR (Fall)	0.28	0.32	0.38	ns
	Data Setup for Input DDR (Rise)	0.25	0.28	0.33	ns
$t_{\text{DDRIHD}}$	Data Hold for Input DDR (Fall)	0.00	0.00	0.00	ns
	Data Hold for Input DDR (Rise)	0.00	0.00	0.00	ns
$t_{\text{DDRICKR2Q1}}$	Asynchronous Clear-to-Out Out_QR for Input DDR	0.46	0.53	0.62	ns
$t_{\text{DDRICKR2Q2}}$	Asynchronous Clear-to-Out Out_QF for Input DDR	0.57	0.65	0.76	ns
$t_{\text{DDRIREMCLR}}$	Asynchronous Clear Removal time for Input DDR	0.00	0.00	0.00	ns
$t_{\text{DDRIRECLLR}}$	Asynchronous Clear Recovery time for Input DDR	0.22	0.25	0.30	ns
$t_{\text{DDRIWCLR}}$	Asynchronous Clear Minimum Pulse Width for Input DDR	0.22	0.25	0.30	ns
$t_{\text{DDRICKMPWH}}$	Clock Minimum Pulse Width High for Input DDR	0.36	0.41	0.48	ns
$t_{\text{DDRICKMPWL}}$	Clock Minimum Pulse Width Low for Input DDR	0.32	0.37	0.43	ns
$F_{\text{DDRIMAX}}$	Maximum Frequency for Input DDR	350.00	350.00	350.00	MHz

*Note:* For specific junction temperature and voltage-supply levels, refer to [Table 2-6 on page 2-5](#) for derating values.

## Output DDR Module

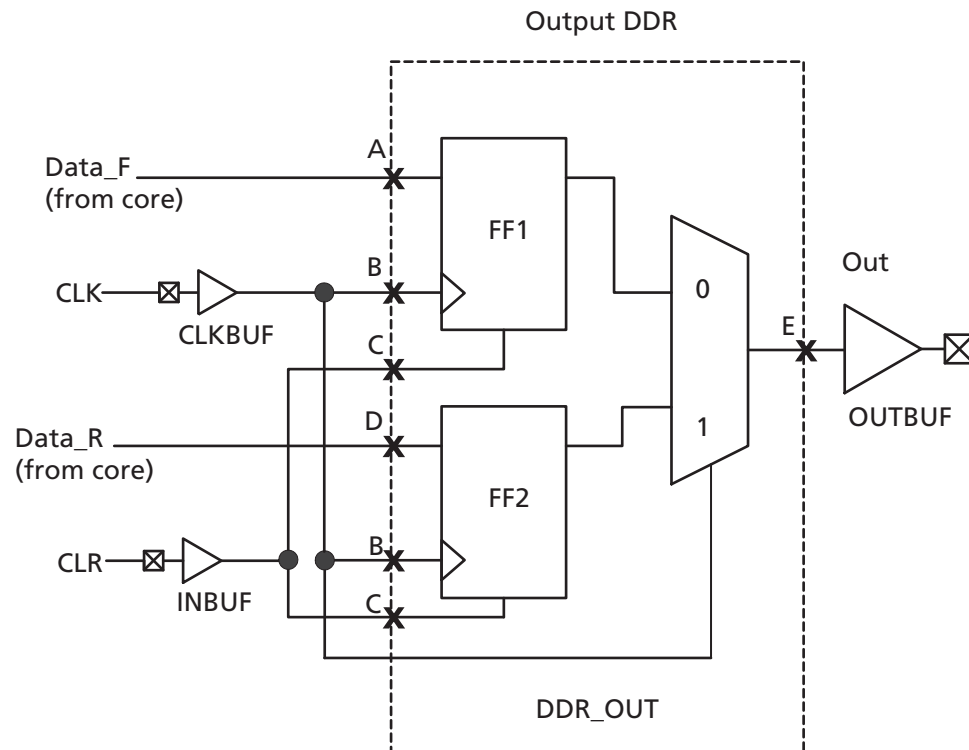
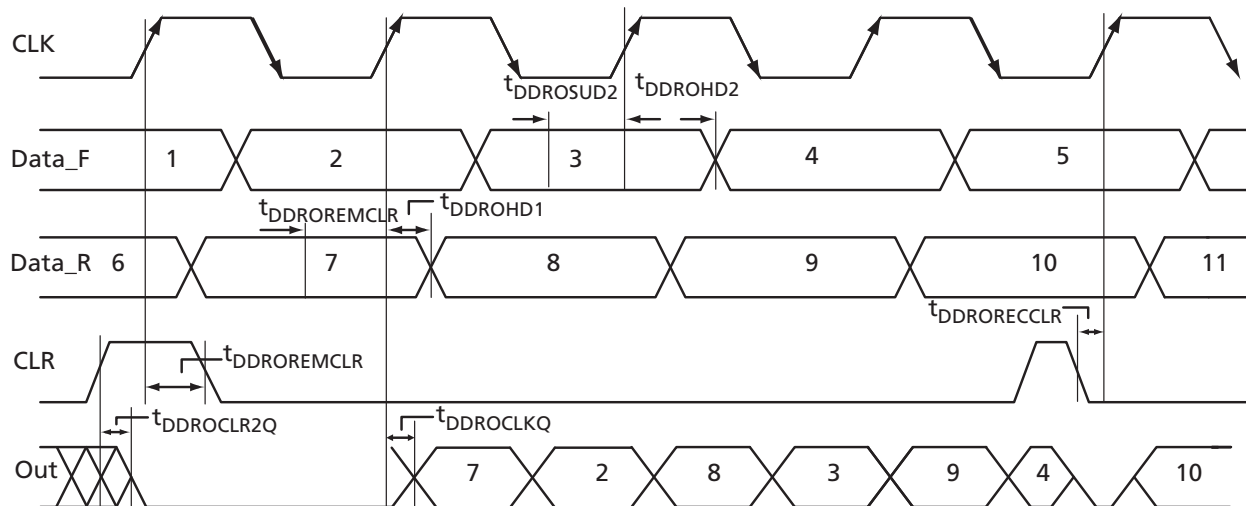

Figure 2-17 • Output DDR Timing Model

Table 2-63 • Parameter Definitions

Parameter Name	Parameter Definition	Measuring Nodes (from, to)
$t_{DDROCLKQ}$	Clock-to-Out	B, E
$t_{DDROCLR2Q}$	Asynchronous Clear-to-Out	C, E
$t_{DDROREMCLR}$	Clear Removal	C, B
$t_{DDRORECCLR}$	Clear Recovery	C, B
$t_{DDROSUD1}$	Data Setup Data_F	A, B
$t_{DDROSUD2}$	Data Setup Data_R	D, B
$t_{DDROHD1}$	Data Hold Data_F	A, B
$t_{DDROHD2}$	Data Hold Data_R	D, B

**Figure 2-18 • Output DDR Timing Diagram**

### Timing Characteristics

**Table 2-64 • Output DDR Propagation Delays**

 Commercial-Case Conditions:  $T_J = 70^\circ\text{C}$ , Worst-Case  $V_{CC} = 1.425\text{ V}$ 

Parameter	Description	-2	-1	Std.	Units
$t_{\text{DDROCLKQ}}$	Clock-to-Out of DDR for Output DDR	0.70	0.80	0.94	ns
$t_{\text{DDROSUD1}}$	Data_F Data Setup for Output DDR	0.38	0.43	0.51	ns
$t_{\text{DDROSUD2}}$	Data_R Data Setup for Output DDR	0.38	0.43	0.51	ns
$t_{\text{DDROHD1}}$	Data_F Data Hold for Output DDR	0.00	0.00	0.00	ns
$t_{\text{DDROHD2}}$	Data_R Data Hold for Output DDR	0.00	0.00	0.00	ns
$t_{\text{DDROCLR2Q}}$	Asynchronous Clear-to-Out for Output DDR	0.80	0.91	1.07	ns
$t_{\text{DDROEMCLR}}$	Asynchronous Clear Removal Time for Output DDR	0.00	0.00	0.00	ns
$t_{\text{DDROECCLR}}$	Asynchronous Clear Recovery Time for Output DDR	0.22	0.25	0.30	ns
$t_{\text{DDROWCLR1}}$	Asynchronous Clear Minimum Pulse Width for Output DDR	0.22	0.25	0.30	ns
$t_{\text{DDROCKMPWH}}$	Clock Minimum Pulse Width HIGH for the Output DDR	0.36	0.41	0.48	ns
$t_{\text{DDROCKMPWL}}$	Clock Minimum Pulse Width LOW for the Output DDR	0.32	0.37	0.43	ns
$F_{\text{DDOMAX}}$	Maximum Frequency for the Output DDR	350.00	350.00	350.00	MHz

*Note:* For specific junction temperature and voltage supply levels, refer to Table 2-6 on page 2-5 for derating values.

## VersaTile Characteristics

### VersaTile Specifications as a Combinatorial Module

The ProASIC3 library offers all combinations of LUT-3 combinatorial functions. In this section, timing characteristics are presented for a sample of the library. For more details, refer to the *Fusion*, *IGLOO<sup>®</sup>e*, and *ProASIC3/E Macro Library Guide*.

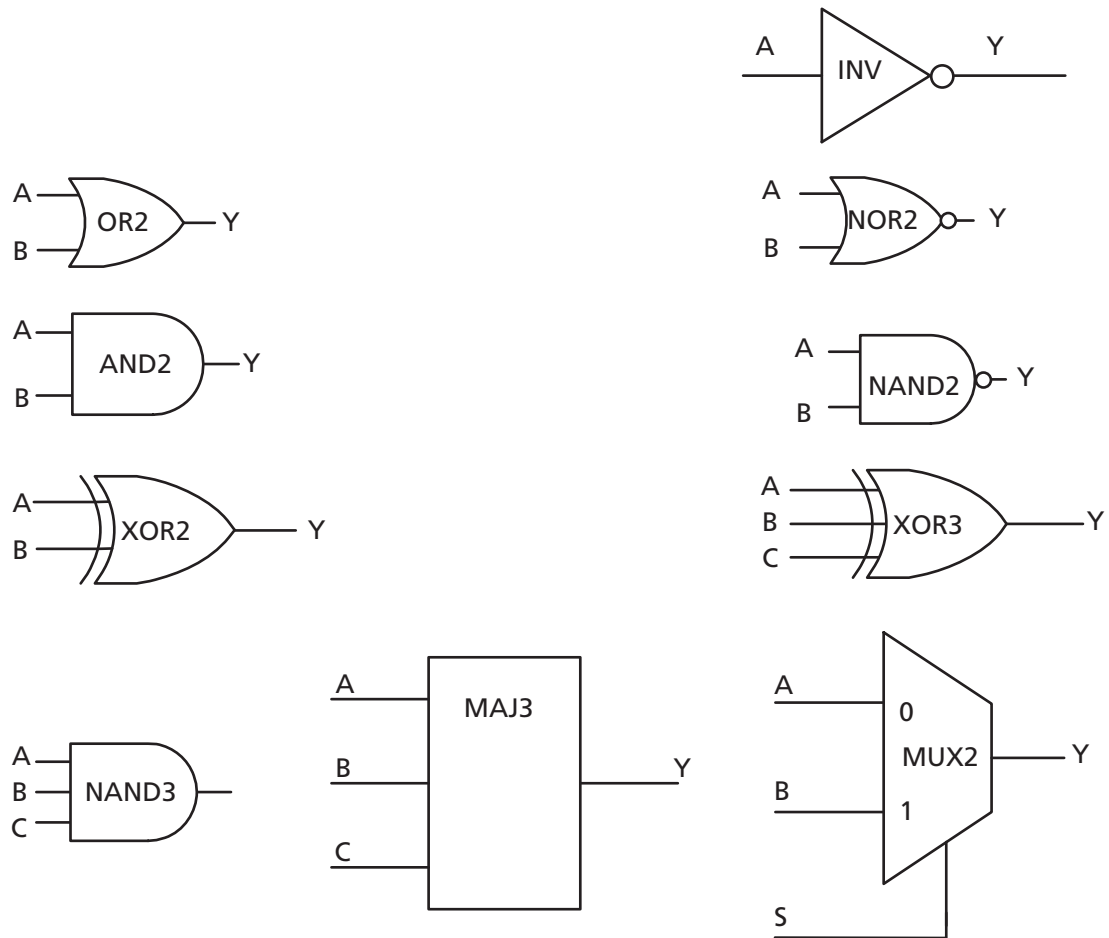

Figure 2-19 • Sample of Combinatorial Cells

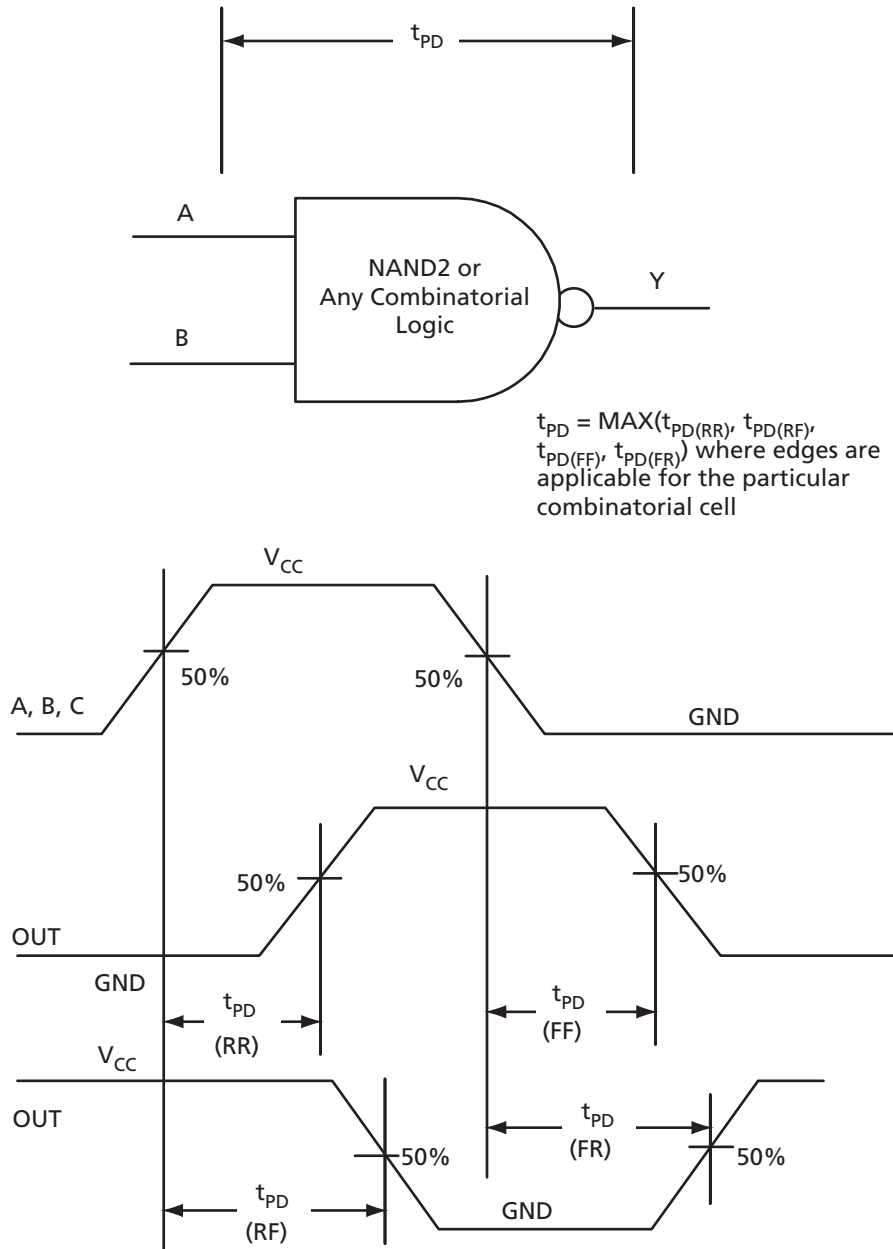

Figure 2-20 • Timing Model and Waveforms

## Timing Characteristics

**Table 2-65 • Combinatorial Cell Propagation Delays**

 Commercial-Case Conditions:  $T_j = 70^\circ\text{C}$ , Worst-Case  $V_{CC} = 1.425\text{ V}$ 

Combinatorial Cell	Equation	Parameter	-2	-1	Std.	Units
INV	$Y = !A$	$t_{PD}$	0.40	0.46	0.54	ns
AND2	$Y = A \cdot B$	$t_{PD}$	0.47	0.54	0.63	ns
NAND2	$Y = !(A \cdot B)$	$t_{PD}$	0.47	0.54	0.63	ns
OR2	$Y = A + B$	$t_{PD}$	0.49	0.55	0.65	ns
NOR2	$Y = !(A + B)$	$t_{PD}$	0.49	0.55	0.65	ns
XOR2	$Y = A \oplus B$	$t_{PD}$	0.74	0.84	0.99	ns
MAJ3	$Y = \text{MAJ}(A, B, C)$	$t_{PD}$	0.70	0.79	0.93	ns
XOR3	$Y = A \oplus B \oplus C$	$t_{PD}$	0.87	1.00	1.17	ns
MUX2	$Y = A \text{ IS } + B \text{ S}$	$t_{PD}$	0.51	0.58	0.68	ns
AND3	$Y = A \cdot B \cdot C$	$t_{PD}$	0.56	0.64	0.75	ns

*Note:* For specific junction temperature and voltage supply levels, refer to [Table 2-6 on page 2-5](#) for derating values.

## VersaTile Specifications as a Sequential Module

The ProASIC3 library offers a wide variety of sequential cells, including flip-flops and latches. Each has a data input and optional enable, clear, or preset. In this section, timing characteristics are presented for a representative sample from the library. For more details, refer to the [Fusion](#), [IGLOO/e](#), and [ProASIC3/E Macro Library Guide](#).

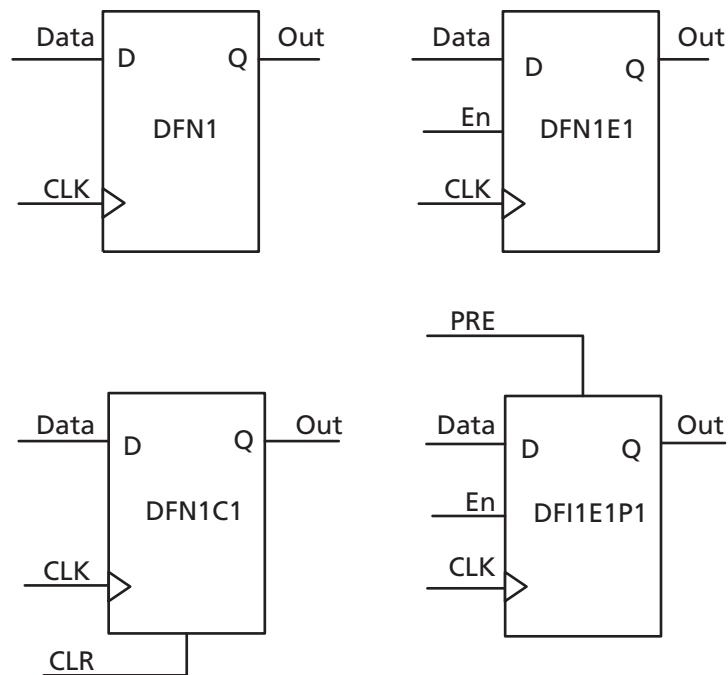
**Figure 2-21 • Sample of Sequential Cells**

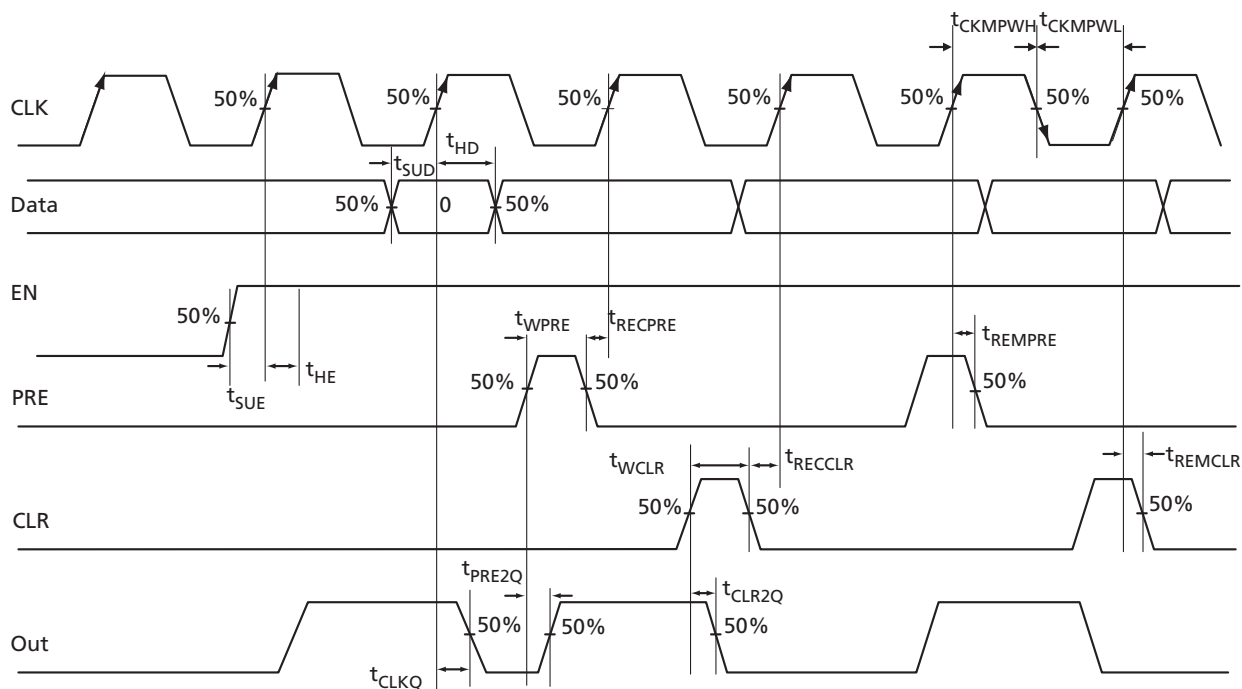
**Figure 2-22 • Timing Model and Waveforms**

### Timing Characteristics

**Table 2-66 • Register Delays**

 Commercial-Case Conditions:  $T_J = 70^\circ\text{C}$ , Worst-Case  $V_{CC} = 1.425\text{ V}$ 

Parameter	Description	-2	-1	Std.	Units
$t_{CLKQ}$	Clock-to-Q of the Core Register	0.55	0.63	0.74	ns
$t_{SUD}$	Data Setup Time for the Core Register	0.43	0.49	0.57	ns
$t_{HD}$	Data Hold Time for the Core Register	0.00	0.00	0.00	ns
$t_{SUE}$	Enable Setup Time for the Core Register	0.45	0.52	0.61	ns
$t_{HE}$	Enable Hold Time for the Core Register	0.00	0.00	0.00	ns
$t_{CLR2Q}$	Asynchronous Clear-to-Q of the Core Register	0.40	0.45	0.53	ns
$t_{PRE2Q}$	Asynchronous Preset-to-Q of the Core Register	0.40	0.45	0.53	ns
$t_{REMCLR}$	Asynchronous Clear Removal Time for the Core Register	0.00	0.00	0.00	ns
$t_{RECLR}$	Asynchronous Clear Recovery Time for the Core Register	0.22	0.25	0.30	ns
$t_{REMPRE}$	Asynchronous Preset Removal Time for the Core Register	0.00	0.00	0.00	ns
$t_{RECPRE}$	Asynchronous Preset Recovery Time for the Core Register	0.22	0.25	0.30	ns
$t_{WCLR}$	Asynchronous Clear Minimum Pulse Width for the Core Register	0.22	0.25	0.30	ns
$t_{WPRE}$	Asynchronous Preset Minimum Pulse Width for the Core Register	0.22	0.25	0.30	ns
$t_{CKMPWH}$	Clock Minimum Pulse Width HIGH for the Core Register	0.36	0.41	0.48	ns
$t_{CKMPWL}$	Clock Minimum Pulse Width LOW for the Core Register	0.32	0.37	0.43	ns

Note: For specific junction temperature and voltage supply levels, refer to Table 2-6 on page 2-5 for derating values.

## Global Resource Characteristics

### A3PN250 Clock Tree Topology

Clock delays are device-specific. Figure 2-23 is an example of a global tree used for clock routing. The global tree presented in Figure 2-23 is driven by a CCC located on the west side of the A3PN250 device. It is used to drive all D-flip-flops in the device.

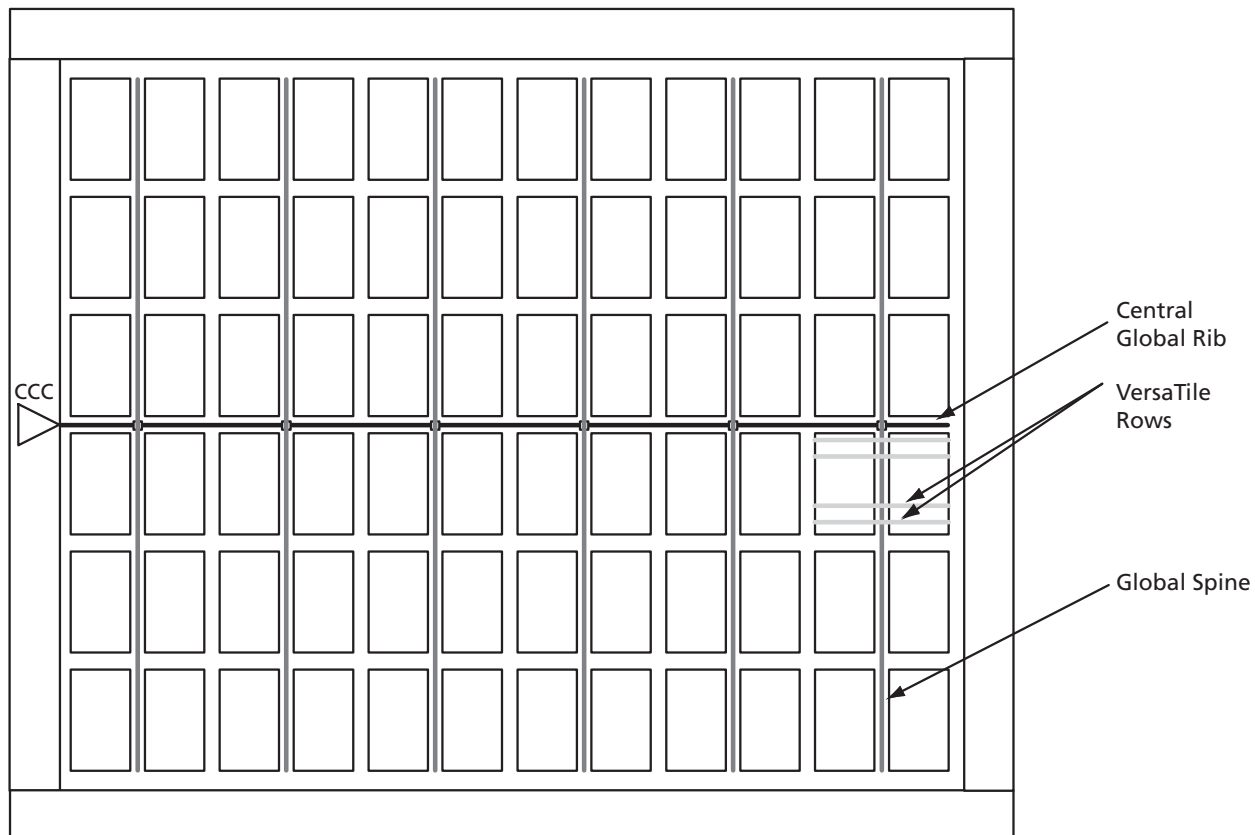

Figure 2-23 • Example of Global Tree Use in an A3PN250 Device for Clock Routing

## Global Tree Timing Characteristics

Global clock delays include the central rib delay, the spine delay, and the row delay. Delays do not include I/O input buffer clock delays, as these are I/O standard-dependent, and the clock may be driven and conditioned internally by the CCC module. For more details on clock conditioning capabilities, refer to the "Clock Conditioning Circuits" section on page 2-57. Table 2-67 to Table 2-72 on page 2-56 present minimum and maximum global clock delays within each device. Minimum and maximum delays are measured with minimum and maximum loading.

### Timing Characteristics

**Table 2-67 • A3PN010 Global Resource**  
Commercial-Case Conditions:  $T_J = 70^\circ\text{C}$ ,  $V_{CC} = 1.425\text{ V}$

Parameter	Description	-2		-1		Std.		Units
		Min. <sup>1</sup>	Max. <sup>2</sup>	Min. <sup>1</sup>	Max. <sup>2</sup>	Min. <sup>1</sup>	Max. <sup>2</sup>	
$t_{RCKL}$	Input LOW Delay for Global Clock	0.60	0.79	0.69	0.90	0.81	1.06	ns
$t_{RCKH}$	Input HIGH Delay for Global Clock	0.62	0.84	0.70	0.96	0.82	1.12	ns
$t_{RCKMPWH}$	Minimum Pulse Width HIGH for Global Clock							ns
$t_{RCKMPWL}$	Minimum Pulse Width LOW for Global Clock							ns
$t_{RCKSW}$	Maximum Skew for Global Clock		0.22		0.26		0.30	ns
$F_{RMAX}$	Maximum Frequency for Global Clock							MHz

#### Notes:

- Value reflects minimum load. The delay is measured from the CCC output to the clock pin of a sequential element, located in a lightly loaded row (single element is connected to the global net).
- Value reflects maximum load. The delay is measured on the clock pin of the farthest sequential element, located in a fully loaded row (all available flip-flops are connected to the global net in the row).
- For specific junction temperature and voltage-supply levels, refer to Table 2-6 on page 2-5 for derating values.

**Table 2-68 • A3PN015 Global Resource**  
Commercial-Case Conditions:  $T_J = 70^\circ\text{C}$ ,  $V_{CC} = 1.425\text{ V}$

Parameter	Description	-2		-1		Std.		Units
		Min. <sup>1</sup>	Max. <sup>2</sup>	Min. <sup>1</sup>	Max. <sup>2</sup>	Min. <sup>1</sup>	Max. <sup>2</sup>	
$t_{RCKL}$	Input LOW Delay for Global Clock	0.66	0.91	0.75	1.04	0.89	1.22	ns
$t_{RCKH}$	Input HIGH Delay for Global Clock	0.67	0.96	0.77	1.10	0.90	1.29	ns
$t_{RCKMPWH}$	Minimum Pulse Width HIGH for Global Clock							ns
$t_{RCKMPWL}$	Minimum Pulse Width LOW for Global Clock							ns
$t_{RCKSW}$	Maximum Skew for Global Clock		0.29		0.33		0.39	ns
$F_{RMAX}$	Maximum Frequency for Global Clock							MHz

#### Notes:

- Value reflects minimum load. The delay is measured from the CCC output to the clock pin of a sequential element, located in a lightly loaded row (single element is connected to the global net).
- Value reflects maximum load. The delay is measured on the clock pin of the farthest sequential element, located in a fully loaded row (all available flip-flops are connected to the global net in the row).
- For specific junction temperature and voltage-supply levels, refer to Table 2-6 on page 2-5 for derating values.

**Table 2-69 • A3PN020 Global Resource**  
 Commercial-Case Conditions:  $T_J = 70^\circ\text{C}$ ,  $V_{CC} = 1.425\text{ V}$

Parameter	Description	-2		-1		Std.		Units
		Min. <sup>1</sup>	Max. <sup>2</sup>	Min. <sup>1</sup>	Max. <sup>2</sup>	Min. <sup>1</sup>	Max. <sup>2</sup>	
$t_{RCKL}$	Input LOW Delay for Global Clock	0.66	0.91	0.75	1.04	0.89	1.22	ns
$t_{RCKH}$	Input HIGH Delay for Global Clock	0.67	0.96	0.77	1.10	0.90	1.29	ns
$t_{RCKMPWH}$	Minimum Pulse Width HIGH for Global Clock							ns
$t_{RCKMPWL}$	Minimum Pulse Width LOW for Global Clock							ns
$t_{RCKSW}$	Maximum Skew for Global Clock		0.29		0.33		0.39	ns
$F_{RMAX}$	Maximum Frequency for Global Clock							MHz

**Notes:**

1. Value reflects minimum load. The delay is measured from the CCC output to the clock pin of a sequential element, located in a lightly loaded row (single element is connected to the global net).
2. Value reflects maximum load. The delay is measured on the clock pin of the farthest sequential element, located in a fully loaded row (all available flip-flops are connected to the global net in the row).
3. For specific junction temperature and voltage-supply levels, refer to [Table 2-6 on page 2-5](#) for derating values.

**Table 2-70 • A3PN060 Global Resource**  
 Commercial-Case Conditions:  $T_J = 70^\circ\text{C}$ ,  $V_{CC} = 1.425\text{ V}$

Parameter	Description	-2		-1		Std.		Units
		Min. <sup>1</sup>	Max. <sup>2</sup>	Min. <sup>1</sup>	Max. <sup>2</sup>	Min. <sup>1</sup>	Max. <sup>2</sup>	
$t_{RCKL}$	Input LOW Delay for Global Clock	0.72	0.91	0.82	1.04	0.96	1.22	ns
$t_{RCKH}$	Input HIGH Delay for Global Clock	0.71	0.94	0.81	1.07	0.96	1.26	ns
$t_{RCKMPWH}$	Minimum Pulse Width HIGH for Global Clock							ns
$t_{RCKMPWL}$	Minimum Pulse Width LOW for Global Clock							ns
$t_{RCKSW}$	Maximum Skew for Global Clock		0.23		0.26		0.31	ns
$F_{RMAX}$	Maximum Frequency for Global Clock							MHz

**Notes:**

1. Value reflects minimum load. The delay is measured from the CCC output to the clock pin of a sequential element, located in a lightly loaded row (single element is connected to the global net).
2. Value reflects maximum load. The delay is measured on the clock pin of the farthest sequential element, located in a fully loaded row (all available flip-flops are connected to the global net in the row).
3. For specific junction temperature and voltage-supply levels, refer to [Table 2-6 on page 2-5](#) for derating values.

**Table 2-71 • A3PN125 Global Resource**  
 Commercial-Case Conditions:  $T_J = 70^\circ\text{C}$ ,  $V_{CC} = 1.425\text{ V}$

Parameter	Description	-2		-1		Std.		Units
		Min. <sup>1</sup>	Max. <sup>2</sup>	Min. <sup>1</sup>	Max. <sup>2</sup>	Min. <sup>1</sup>	Max. <sup>2</sup>	
$t_{RCKL}$	Input LOW Delay for Global Clock	0.76	0.99	0.87	1.12	1.02	1.32	ns
$t_{RCKH}$	Input HIGH Delay for Global Clock	0.76	1.02	0.87	1.17	1.02	1.37	ns
$t_{RCKMPWH}$	Minimum Pulse Width HIGH for Global Clock							ns
$t_{RCKMPWL}$	Minimum Pulse Width LOW for Global Clock							ns
$t_{RCKSW}$	Maximum Skew for Global Clock		0.26		0.30		0.35	ns
$F_{RMAX}$	Maximum Frequency for Global Clock							MHz

**Notes:**

1. Value reflects minimum load. The delay is measured from the CCC output to the clock pin of a sequential element, located in a lightly loaded row (single element is connected to the global net).
2. Value reflects maximum load. The delay is measured on the clock pin of the farthest sequential element, located in a fully loaded row (all available flip-flops are connected to the global net in the row).
3. For specific junction temperature and voltage-supply levels, refer to [Table 2-6 on page 2-5](#) for derating values.

**Table 2-72 • A3PN250 Global Resource**  
 Commercial-Case Conditions:  $T_J = 70^\circ\text{C}$ ,  $V_{CC} = 1.425\text{ V}$

Parameter	Description	-2		-1		Std.		Units
		Min. <sup>1</sup>	Max. <sup>2</sup>	Min. <sup>1</sup>	Max. <sup>2</sup>	Min. <sup>1</sup>	Max. <sup>2</sup>	
$t_{RCKL}$	Input LOW Delay for Global Clock	0.79	1.02	0.90	1.16	1.06	1.36	ns
$t_{RCKH}$	Input HIGH Delay for Global Clock	0.78	1.04	0.88	1.18	1.04	1.39	ns
$t_{RCKMPWH}$	Minimum Pulse Width HIGH for Global Clock							ns
$t_{RCKMPWL}$	Minimum Pulse Width LOW for Global Clock							ns
$t_{RCKSW}$	Maximum Skew for Global Clock		0.26		0.30		0.35	ns
$F_{RMAX}$	Maximum Frequency for Global Clock							MHz

**Notes:**

1. Value reflects minimum load. The delay is measured from the CCC output to the clock pin of a sequential element, located in a lightly loaded row (single element is connected to the global net).
2. Value reflects maximum load. The delay is measured on the clock pin of the farthest sequential element, located in a fully loaded row (all available flip-flops are connected to the global net in the row).
3. For specific junction temperature and voltage-supply levels, refer to [Table 2-6 on page 2-5](#) for derating values.

# Clock Conditioning Circuits

## CCC Electrical Specifications

### Timing Characteristics

**Table 2-73 • ProASIC3 nano CCC/PLL Specification**

Parameter	Minimum	Typical	Maximum	Units
Clock Conditioning Circuitry Input Frequency $f_{IN\_CCC}$	1.5		350	MHz
Clock Conditioning Circuitry Output Frequency $f_{OUT\_CCC}$	0.75		350	MHz
Delay Increments in Programmable Delay Blocks <sup>1,2</sup>		200		ps
Number of Programmable Values in Each Programmable Delay Block			32	
Serial Clock (SCLK) for Dynamic PLL <sup>3,4</sup>			125	MHz
Input Cycle-to-Cycle Jitter (peak magnitude)			1.5	ns
Acquisition Time				
	LockControl = 0		300	μs
	LockControl = 1		6.0	ms
Tracking Jitter <sup>6</sup>				
	LockControl = 0		1.6	ns
	LockControl = 1		0.8	ns
Output Duty Cycle	48.5		51.5	%
Delay Range in Block: Programmable Delay <sub>1</sub> <sup>1,2</sup>	1.25		15.65	ns
Delay Range in Block: Programmable Delay <sub>2</sub> <sup>1,2</sup>	0.025		15.65	ns
Delay Range in Block: Fixed Delay <sup>1,2</sup>		2.2		ns
VCO Output Peak-to-Peak Period Jitter $F_{CCC\_OUT}$ <sup>5</sup>	Max Peak-to-Peak Jitter Data <sup>5,7,8</sup>			
	SSO ≤ 2	SSO ≤ 4	SSO ≤ 8	SSO ≤ 16
0.75 MHz to 50MHz	0.50%	0.50%	0.70%	1.00%
50 MHz to 250 MHz	1.00%	3.00%	5.00%	9.00%
250 MHz to 350 MHz	2.50%	4.00%	6.00%	12.00%

**Notes:**

1. This delay is a function of voltage and temperature. See [Table 2-6 on page 2-5](#) for deratings.
2.  $T_J = 25^\circ\text{C}$ ,  $V_{CC} = 1.5\text{ V}$
3. Maximum value obtained for a -2 speed-grade device in worst-case commercial conditions. For specific junction temperature and voltage supply levels, refer to [Table 2-6 on page 2-5](#) for derating values.
4. The A3PN010, A3PN015, and A3PN020 devices do not support PLLs.
5. VCO output jitter is calculated as a percentage of the VCO frequency. The jitter (in ps) can be calculated by multiplying the VCO period by the % jitter. The VCO jitter (in ps) applies to CCC\_OUT regardless of the output divider settings. For example, if the jitter on VCO is 300 ps, the jitter on CCC\_OUT is also 300 ps, regardless of the output divider settings.
6. Tracking jitter is defined as the variation in clock edge position of PLL outputs with reference to the PLL input clock edge. Tracking jitter does not measure the variation in PLL output period, which is covered by the period jitter parameter.
7. Measurements done with LVTTTL 3.3 V 8 mA I/O drive strength and high slew rate.  $V_{CC}/V_{CCPLL} = 1.425\text{ V}$ ,  $V_{CCI} = 3.3$ , VQ/PQ/TQ type of packages, 20 pF load.
8. SSOs are outputs that are synchronous to a single clock domain, and have their clock-to-out times within  $\pm 200\text{ ps}$  of each other.

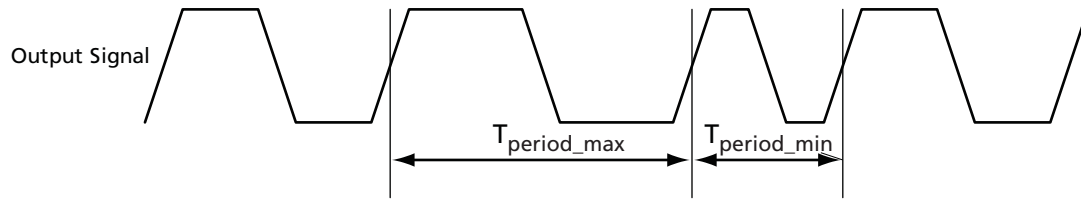

*Note:* Peak-to-peak jitter measurements are defined by  $T_{\text{peak-to-peak}} = T_{\text{period\_max}} - T_{\text{period\_min}}$ .

**Figure 2-24 • Peak-to-Peak Jitter Definition**

# Embedded SRAM and FIFO Characteristics

## SRAM

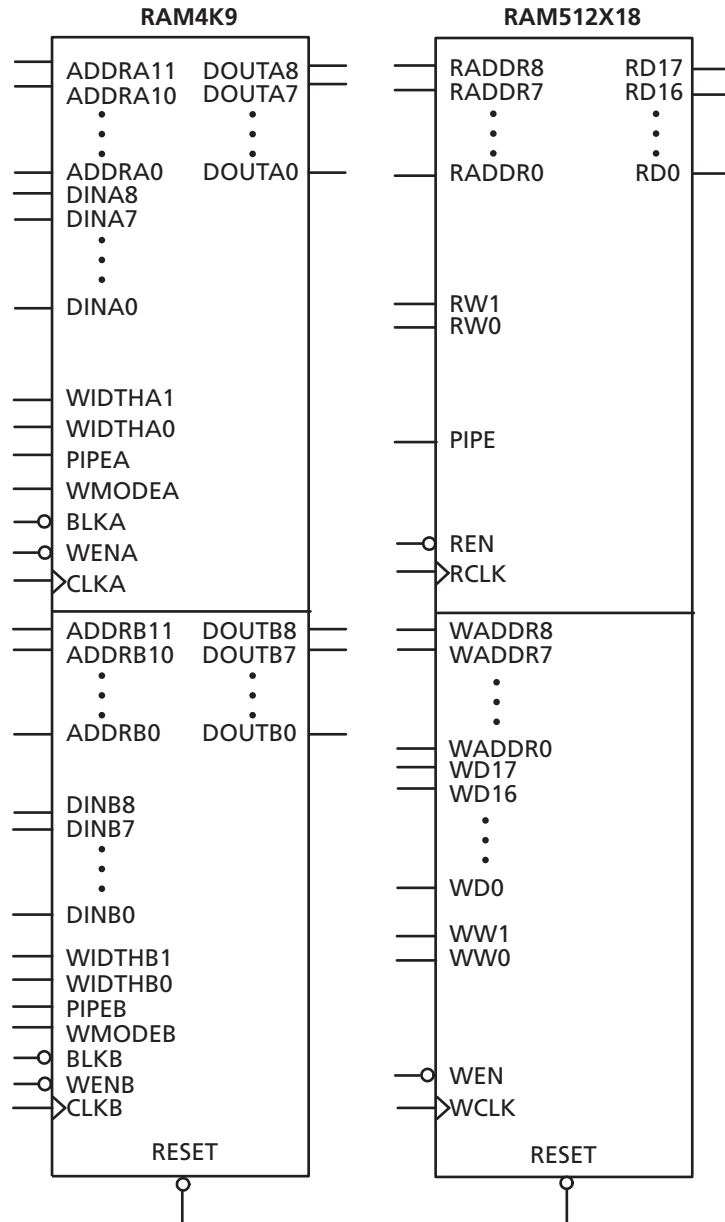

Figure 2-25 • RAM Models

### Timing Waveforms

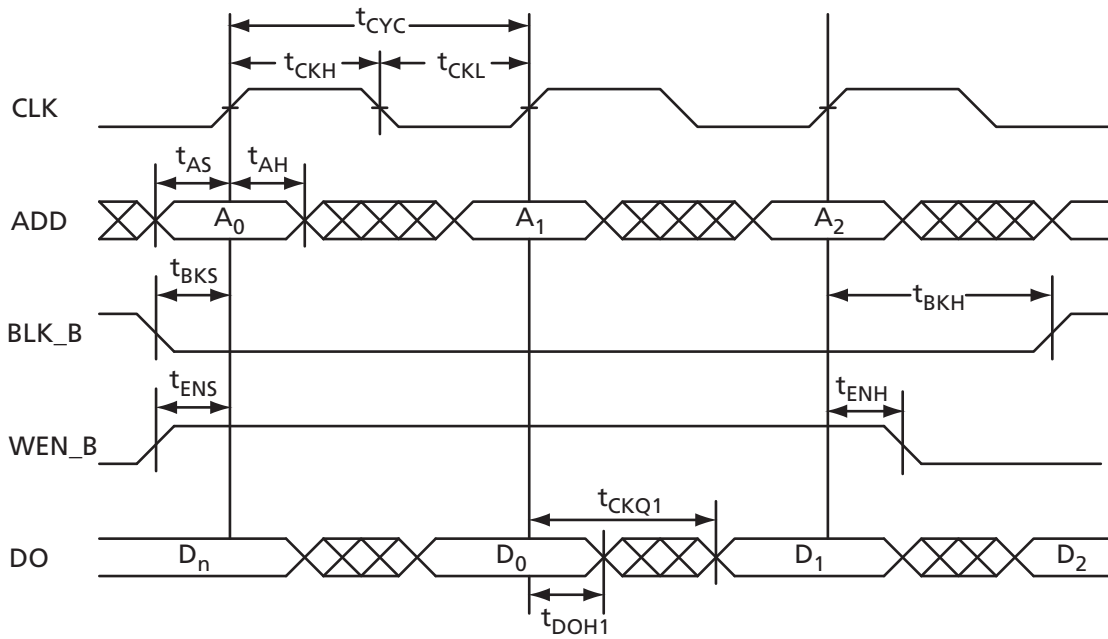

Figure 2-26 • RAM Read for Pass-Through Output

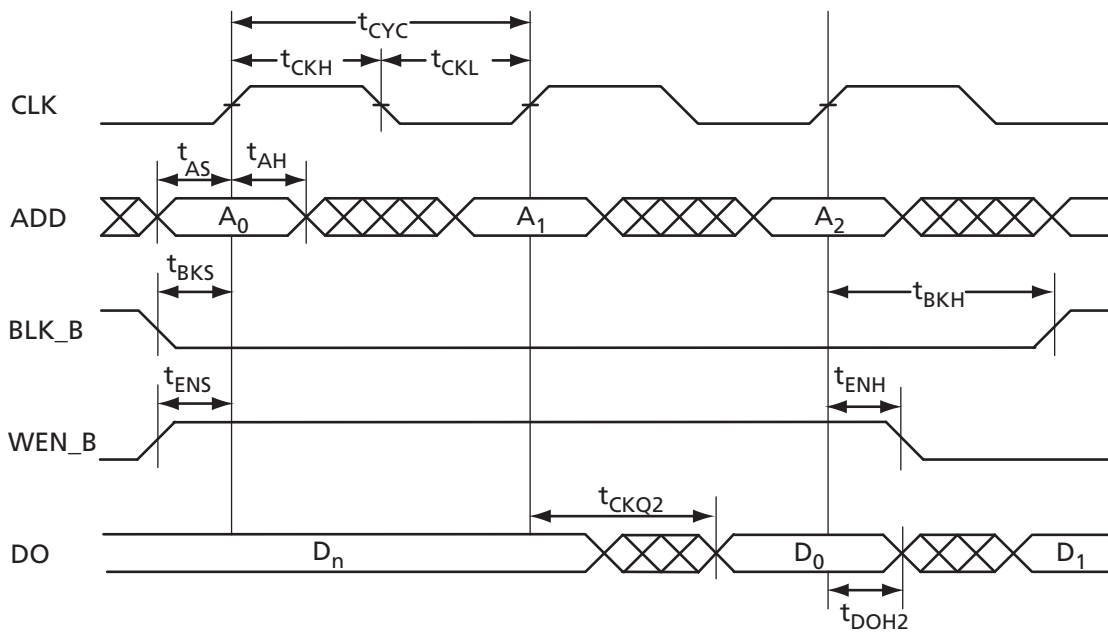

Figure 2-27 • RAM Read for Pipelined Output

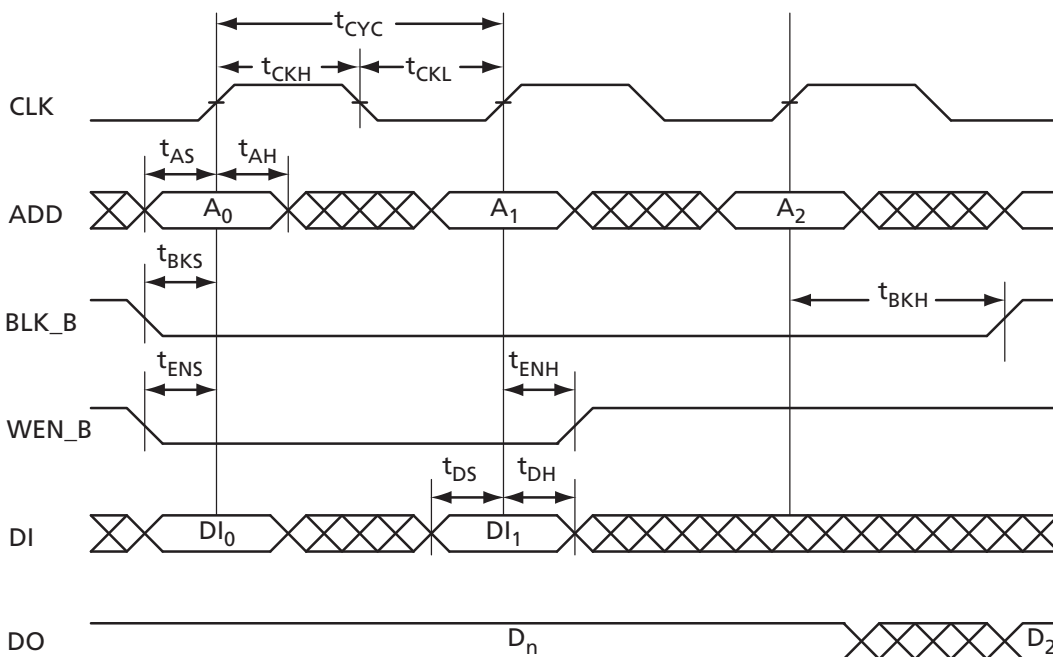

Figure 2-28 • RAM Write, Output Retained (WMODE = 0)

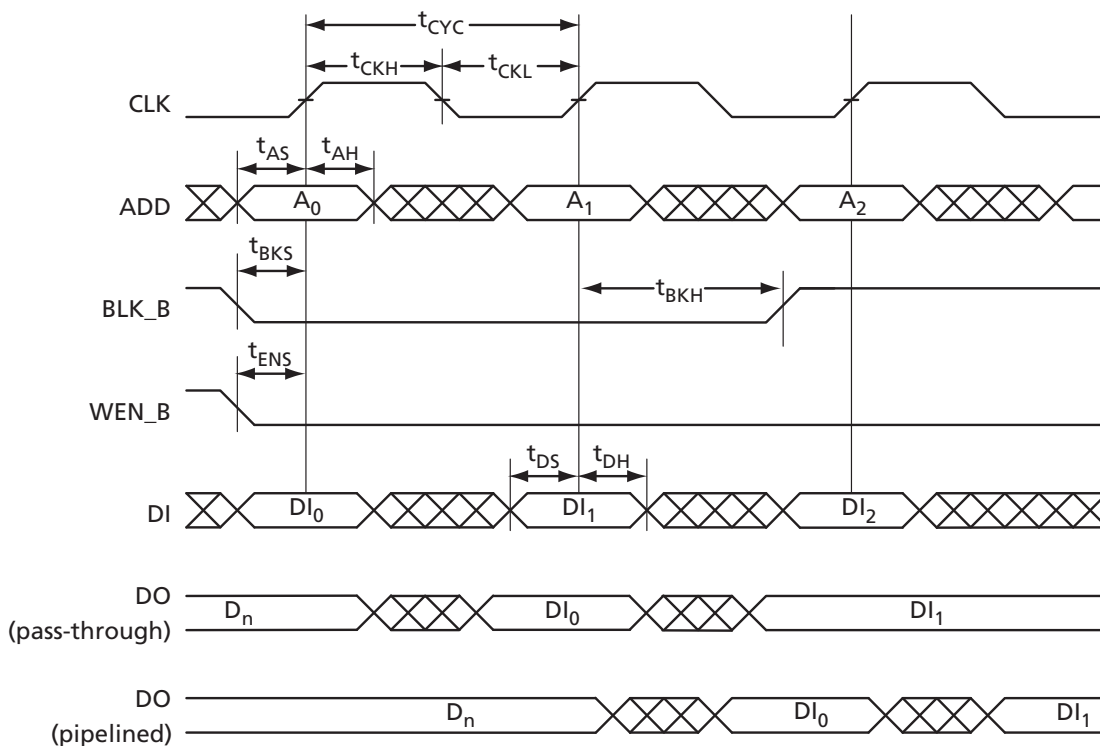

Figure 2-29 • RAM Write, Output as Write Data (WMODE = 1)

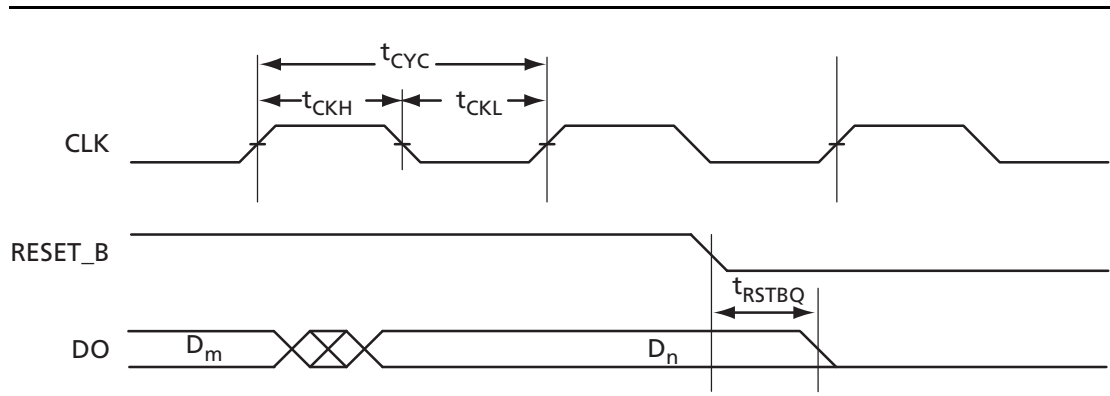

Figure 2-30 • RAM Reset

## Timing Characteristics

Table 2-74 • RAM4K9

Commercial-Case Conditions:  $T_J = 70^\circ\text{C}$ , Worst-Case  $V_{CC} = 1.425\text{ V}$

Parameter	Description	-2	-1	Std.	Units
$t_{AS}$	Address Setup time	0.25	0.28	0.33	ns
$t_{AH}$	Address Hold time	0.00	0.00	0.00	ns
$t_{ENS}$	REN_B, WEN_B Setup time	0.14	0.16	0.19	ns
$t_{ENH}$	REN_B, WEN_B Hold time	0.10	0.11	0.13	ns
$t_{BKS}$	BLK_B Setup time	0.23	0.27	0.31	ns
$t_{BKH}$	BLK_B Hold time	0.02	0.02	0.02	ns
$t_{DS}$	Input data (DI) Setup time	0.18	0.21	0.25	ns
$t_{DH}$	Input data (DI) Hold time	0.00	0.00	0.00	ns
$t_{CKQ1}$	Clock High to New Data Valid on DO (output retained, WMODE = 0)	1.79	2.03	2.39	ns
	Clock High to New Data Valid on DO (flow-through, WMODE = 1)	2.36	2.68	3.15	ns
$t_{CKQ2}$	Clock High to New Data Valid on DO (pipelined)	0.89	1.02	1.20	ns
$t_{C2CWWL}$	Address collision clk-to-clk delay for reliable write after write on same address; applicable to closing edge	0.33	0.28	0.25	ns
$t_{C2CWWH}$	Address collision clk-to-clk delay for reliable write after write on same address; applicable to rising edge	0.30	0.26	0.23	ns
$t_{C2CRWH}$	Address collision clk-to-clk delay for reliable read access after write on same address; applicable to opening edge	0.45	0.38	0.34	ns
$t_{C2CWRH}$	Address collision clk-to-clk delay for reliable write access after read on same address; applicable to opening edge	0.49	0.42	0.37	ns
$t_{RSTBQ}$	RESET_B Low to Data Out Low on DO (flow through)	0.92	1.05	1.23	ns
	RESET_B Low to Data Out Low on DO (pipelined)	0.92	1.05	1.23	ns
$t_{REMRSTB}$	RESET_B Removal	0.29	0.33	0.38	ns
$t_{RECRSTB}$	RESET_B Recovery	1.50	1.71	2.01	ns
$t_{MPWRSTB}$	RESET_B Minimum Pulse Width	0.21	0.24	0.29	ns
$t_{CYC}$	Clock Cycle time	3.23	3.68	4.32	ns
$F_{MAX}$	Maximum Frequency	310	272	231	MHz

Note: For specific junction temperature and voltage-supply levels, refer to Table 3-6 on page 3-4 for derating values.

**Table 2-75 • RAM512X18**
**Commercial-Case Conditions:  $T_J = 70^\circ\text{C}$ , Worst-Case  $V_{CC} = 1.425\text{ V}$** 

Parameter	Description	-2	-1	Std.	Units
$t_{AS}$	Address setup time	0.25	0.28	0.33	ns
$t_{AH}$	Address hold time	0.00	0.00	0.00	ns
$t_{ENS}$	REN_B, WEN_B setup time	0.09	0.10	0.12	ns
$t_{ENH}$	REN_B, WEN_B hold time	0.06	0.07	0.08	ns
$t_{DS}$	Input data (DI) setup time	0.18	0.21	0.25	ns
$t_{DH}$	Input data (DI) hold time	0.00	0.00	0.00	ns
$t_{CKQ1}$	Clock HIGH to new data valid on DO (output retained, WMODE = 0)	2.16	2.46	2.89	ns
$t_{CKQ2}$	Clock HIGH to new data valid on DO (pipelined)	0.90	1.02	1.20	ns
$t_{C2CRWH}$	Address collision clk-to-clk delay for reliable read access after write on same address; applicable to opening edge	0.50	0.43	0.38	ns
$t_{C2CWRH}$	Address collision clk-to-clk delay for reliable write access after read on same address; applicable to opening edge	0.59	0.50	0.44	ns
$t_{RSTBQ}$	RESET_B LOW to data out LOW on DO (flow-through)	0.92	1.05	1.23	ns
	RESET_B LOW to data out LOW on DO (pipelined)	0.92	1.05	1.23	ns
$t_{REMRSTB}$	RESET_B removal	0.29	0.33	0.38	ns
$t_{RECRSTB}$	RESET_B recovery	1.50	1.71	2.01	ns
$t_{MPWRSTB}$	RESET_B minimum pulse width	0.21	0.24	0.29	ns
$t_{CYC}$	Clock cycle time	3.23	3.68	4.32	ns
$F_{MAX}$	Maximum frequency	310	272	231	MHz

*Note:* For specific junction temperature and voltage supply levels, refer to [Table 2-6 on page 2-5](#) for derating values.

## FIFO

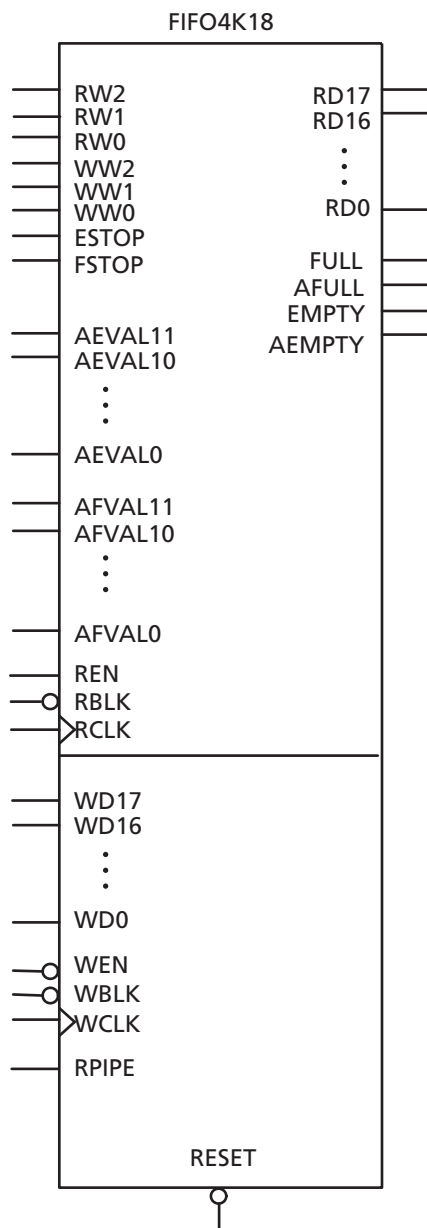

Figure 2-31 • FIFO Model

### Timing Waveforms

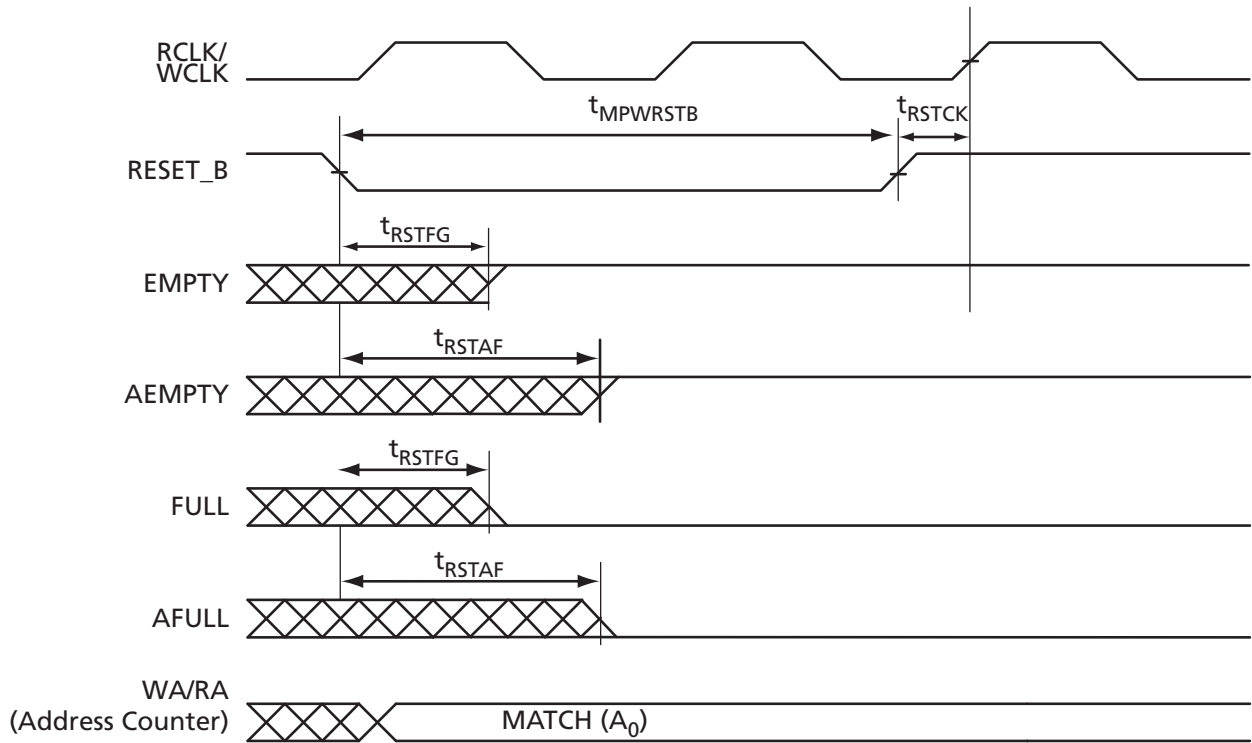

Figure 2-32 • FIFO Reset

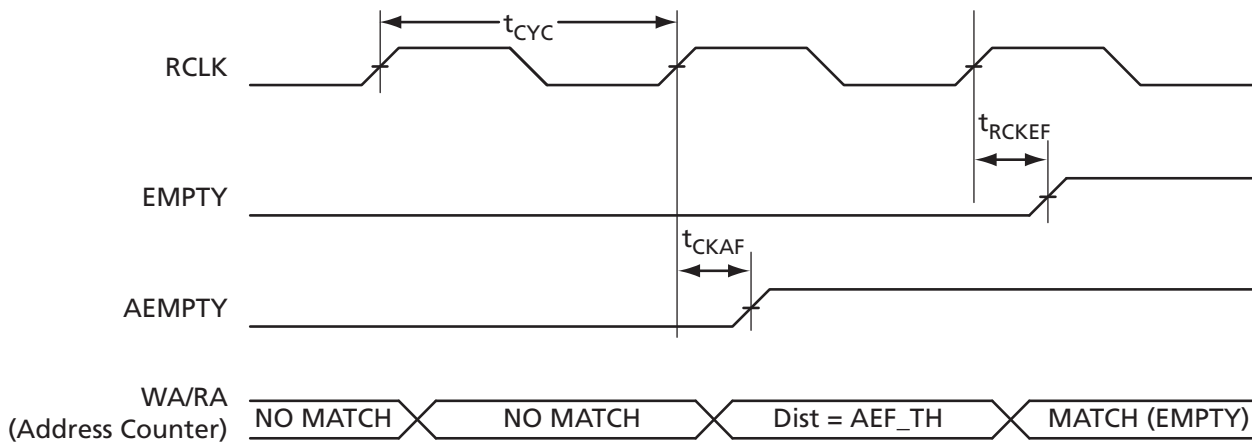
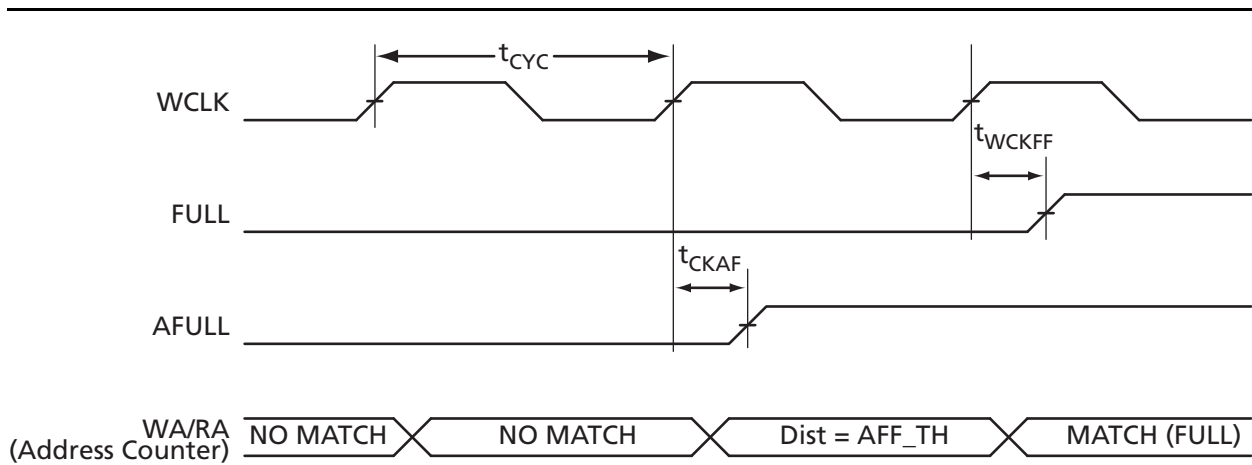
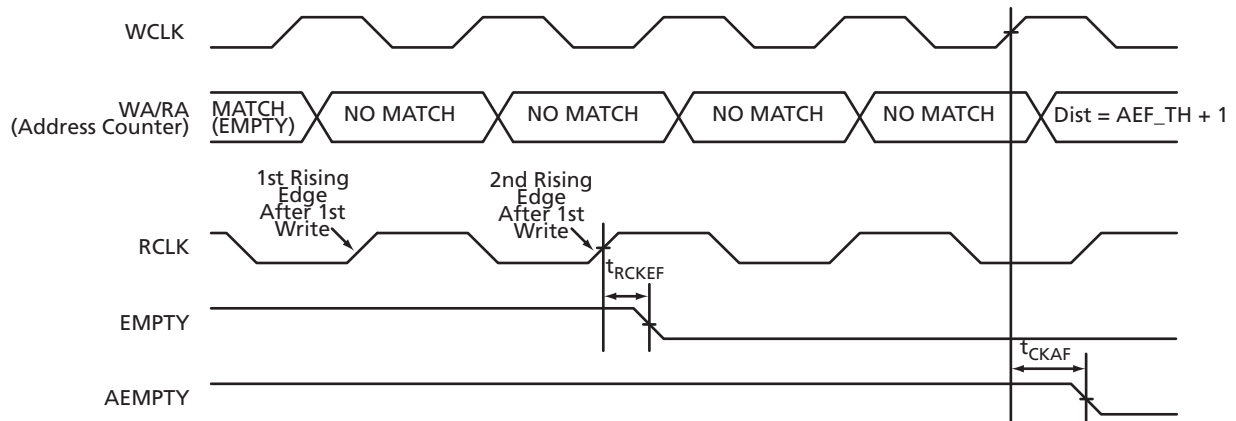
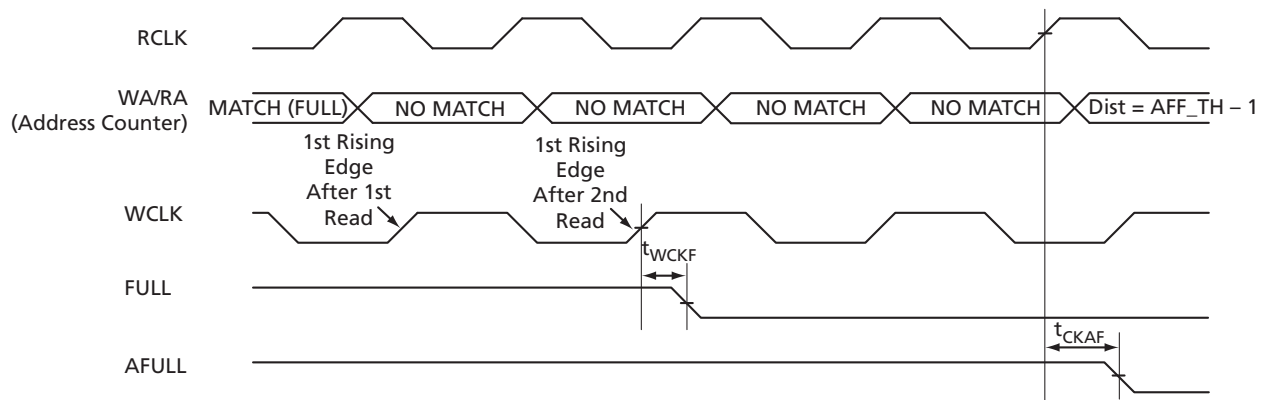

Figure 2-33 • FIFO EMPTY Flag and AEMPTY Flag Assertion

**Figure 2-34 • FIFO FULL Flag and AFULL Flag Assertion**

**Figure 2-35 • FIFO EMPTY Flag and AEMPTY Flag Deassertion**

**Figure 2-36 • FIFO FULL Flag and AFULL Flag Deassertion**

## Timing Characteristics

**Table 2-76 • FIFO**
**Worst Commercial-Case Conditions:  $T_J = 70^\circ\text{C}$ ,  $V_{CC} = 1.425\text{ V}$** 

Parameter	Description	-2	-1	Std.	Units
$t_{ENS}$	REN_B, WEN_B Setup Time	1.38	1.57	1.84	ns
$t_{ENH}$	REN_B, WEN_B Hold Time	0.02	0.02	0.02	ns
$t_{BKS}$	BLK_B Setup Time	0.22	0.25	0.30	ns
$t_{BKH}$	BLK_B Hold Time	0.00	0.00	0.00	ns
$t_{DS}$	Input Data (DI) Setup Time	0.18	0.21	0.25	ns
$t_{DH}$	Input Data (DI) Hold Time	0.00	0.00	0.00	ns
$t_{CKQ1}$	Clock HIGH to New Data Valid on DO (flow-through)	2.36	2.68	3.15	ns
$t_{CKQ2}$	Clock HIGH to New Data Valid on DO (pipelined)	0.89	1.02	1.20	ns
$t_{RCKEF}$	RCLK HIGH to Empty Flag Valid	1.72	1.96	2.30	ns
$t_{WCKFF}$	WCLK HIGH to Full Flag Valid	1.63	1.86	2.18	ns
$t_{CKAF}$	Clock HIGH to Almost Empty/Full Flag Valid	6.19	7.05	8.29	ns
$t_{RSTFG}$	RESET_B LOW to Empty/Full Flag Valid	1.69	1.93	2.27	ns
$t_{RSTAF}$	RESET_B LOW to Almost Empty/Full Flag Valid	6.13	6.98	8.20	ns
$t_{RSTBQ}$	RESET_B LOW to Data Out LOW on DO (flow-through)	0.92	1.05	1.23	ns
	RESET_B LOW to Data Out LOW on DO (pipelined)	0.92	1.05	1.23	ns
$t_{REMRSTB}$	RESET_B Removal	0.29	0.33	0.38	ns
$t_{RECRSTB}$	RESET_B Recovery	1.50	1.71	2.01	ns
$t_{MPWRSTB}$	RESET_B Minimum Pulse Width	0.21	0.24	0.29	ns
$t_{CYC}$	Clock Cycle Time	3.23	3.68	4.32	ns
$F_{MAX}$	Maximum Frequency for FIFO	310	272	231	MHz

*Note:* For specific junction temperature and voltage supply levels, refer to [Table 2-6 on page 2-5](#) for derating values.

## Embedded FlashROM Characteristics

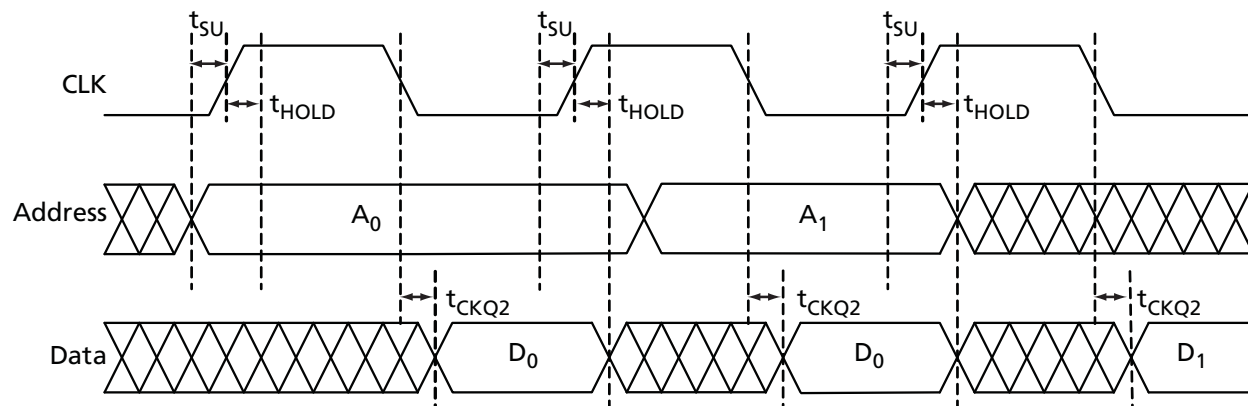

Figure 2-37 • Timing Diagram

### Timing Characteristics

Table 2-77 • Embedded FlashROM Access Time

Commercial-Case Conditions:  $T_J = 70^\circ\text{C}$ , Worst-Case  $V_{CC} = 1.425\text{ V}$

Parameter	Description	-2	-1	Std.	Units
$t_{SU}$	Address Setup Time	0.53	0.61	0.71	ns
$t_{HOLD}$	Address Hold Time	0.00	0.00	0.00	ns
$t_{CKQ2}$	Clock to Out	16.23	18.48	21.73	ns
$F_{MAX}$	Maximum Clock Frequency	15.00	15.00	15.00	MHz

## JTAG 1532 Characteristics

JTAG timing delays do not include JTAG I/Os. To obtain complete JTAG timing, add I/O buffer delays to the corresponding standard selected; refer to the I/O timing characteristics in the "User I/O Characteristics" section on page 2-12 for more details.

Timing Characteristics

**Table 2-78 • JTAG 1532**

**Commercial-Case Conditions:  $T_j = 70^\circ\text{C}$ , Worst-Case VCC = 1.425 V**

Parameter	Description	-2	-1	Std.	Units
$t_{\text{DISU}}$	Test Data Input Setup Time	0.53	0.60	0.71	ns
$t_{\text{DIHD}}$	Test Data Input Hold Time	1.07	1.21	1.42	ns
$t_{\text{TMSU}}$	Test Mode Select Setup Time	0.53	0.60	0.71	ns
$t_{\text{TMDHD}}$	Test Mode Select Hold Time	1.07	1.21	1.42	ns
$t_{\text{TCK2Q}}$	Clock to Q (data out)	6.39	7.24	8.52	ns
$t_{\text{RSTB2Q}}$	Reset to Q (data out)	21.31	24.15	28.41	ns
$F_{\text{TCKMAX}}$	TCK Maximum Frequency	23.00	20.00	17.00	MHz
$t_{\text{TRSTREM}}$	ResetB Removal Time	0.00	0.00	0.00	ns
$t_{\text{TRSTREC}}$	ResetB Recovery Time	0.21	0.24	0.28	ns
$t_{\text{TRSTMPW}}$	ResetB Minimum Pulse	TBD	TBD	TBD	ns

*Note:* For specific junction temperature and voltage supply levels, refer to Table 2-6 on page 2-5 for derating values.

## Actel Safety Critical, Life Support, and High-Reliability Applications Policy

The Actel products described in this advance status datasheet may not have completed Actel's qualification process. Actel may amend or enhance products during the product introduction and qualification process, resulting in changes in device functionality or performance. It is the responsibility of each customer to ensure the fitness of any Actel product (but especially a new product) for a particular purpose, including appropriateness for safety-critical, life-support, and other high-reliability applications. Consult Actel's Terms and Conditions for specific liability exclusions relating to life-support applications. A reliability report covering all of Actel's products is available on the Actel website at [http://www.actel.com/documents/ORT\\_Report.pdf](http://www.actel.com/documents/ORT_Report.pdf). Actel also offers a variety of enhanced qualification and lot acceptance screening procedures. Contact your local Actel sales office for additional reliability information.

## 3 – Package Pin Assignments

### 48-Pin QFN

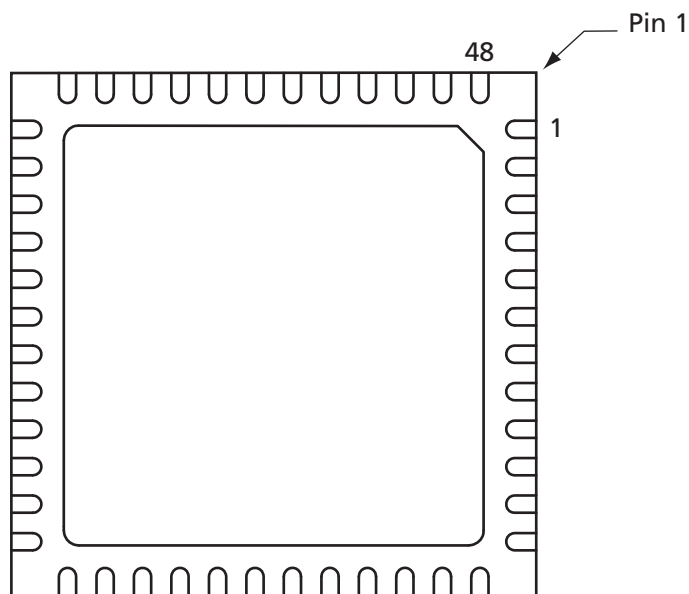

*Notes:*

1. This is the bottom view of the package.
2. The die attach paddle of the package is tied to ground (GND).

**Note**

For Package Manufacturing and Environmental information, visit the Resource Center at <http://www.actel.com/products/solutions/package/docs.aspx>.

48-Pin QFN	
Pin Number	A3PN010 Function
1	GEC0/IO37RSB1
2	IO36RSB1
3	GEA0/IO34RSB1
4	IO22RSB1
5	GND
6	VCCIB1
7	IO24RSB1
8	IO33RSB1
9	IO26RSB1
10	IO32RSB1
11	IO27RSB1
12	IO29RSB1
13	IO30RSB1
14	IO31RSB1
15	IO28RSB1
16	IO25RSB1
17	IO23RSB1
18	VCC
19	VCCIB1
20	IO17RSB1
21	IO14RSB1
22	TCK
23	TDI
24	TMS
25	VPUMP
26	TDO
27	TRST
28	VJTAG
29	IO11RSB0
30	IO10RSB0
31	IO09RSB0
32	IO08RSB0
33	VCCIB0
34	GND
35	VCC

48-Pin QFN	
Pin Number	A3PN010 Function
36	IO07RSB0
37	IO06RSB0
38	GDA0/IO05RSB0
39	IO03RSB0
40	GDC0/IO01RSB0
41	IO12RSB1
42	IO13RSB1
43	IO15RSB1
44	IO16RSB1
45	IO18RSB1
46	IO19RSB1
47	IO20RSB1
48	IO21RSB1

48-Pin QFN	
Pin Number	A3PN030Z Function
1	IO82RSB1
2	GEC0/IO73RSB1
3	GEA0/IO72RSB1
4	GEB0/IO71RSB1
5	GND
6	VCCIB1
7	IO68RSB1
8	IO67RSB1
9	IO66RSB1
10	IO65RSB1
11	IO64RSB1
12	IO62RSB1
13	IO61RSB1
14	IO60RSB1
15	IO57RSB1
16	IO55RSB1
17	IO53RSB1
18	VCC
19	VCCIB1
20	IO46RSB1
21	IO42RSB1
22	TCK
23	TDI
24	TMS
25	VPUMP
26	TDO
27	TRST
28	VJTAG
29	IO38RSB0
30	GDB0/IO34RSB0
31	GDA0/IO33RSB0
32	GDC0/IO32RSB0
33	VCCIB0
34	GND
35	VCC

48-Pin QFN	
Pin Number	A3PN030Z Function
36	IO25RSB0
37	IO24RSB0
38	IO22RSB0
39	IO20RSB0
40	IO18RSB0
41	IO16RSB0
42	IO14RSB0
43	IO10RSB0
44	IO08RSB0
45	IO06RSB0
46	IO04RSB0
47	IO02RSB0
48	IO00RSB0

## 68-Pin QFN

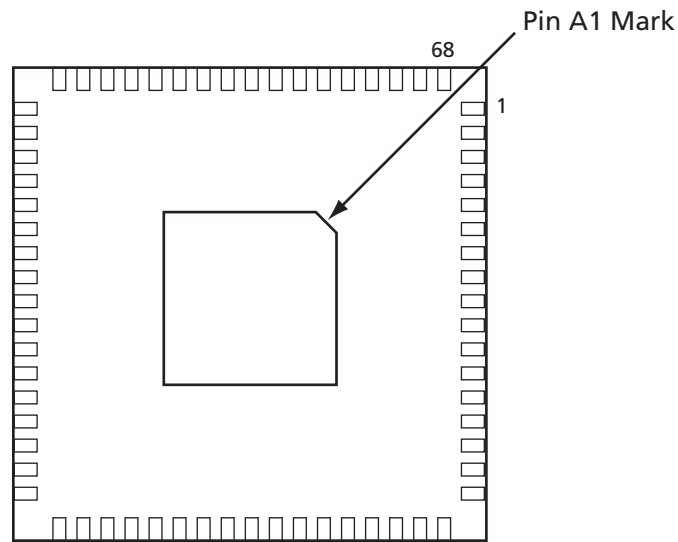

*Notes:*

1. This is the bottom view of the package.
2. The die attach paddle of the package is tied to ground (GND).

**Note**

For Package Manufacturing and Environmental information, visit the Resource Center at <http://www.actel.com/products/solutions/package/docs.aspx>.

68-Pin QFN		68-Pin QFN	
Pin Number	A3PN015 Function	Pin Number	A3PN015 Function
1	IO60RSB2	37	TRST
2	IO54RSB2	38	VJTAG
3	IO52RSB2	39	IO17RSB0
4	IO50RSB2	40	IO16RSB0
5	IO49RSB2	41	GDA0/IO15RSB0
6	GEC0/IO48RSB2	42	GDC0/IO14RSB0
7	GEA0/IO47RSB2	43	IO13RSB0
8	VCC	44	VCCIB0
9	GND	45	GND
10	VCCIB2	46	VCC
11	IO46RSB2	47	IO12RSB0
12	IO45RSB2	48	IO11RSB0
13	IO44RSB2	49	IO09RSB0
14	IO43RSB2	50	IO05RSB0
15	IO42RSB2	51	IO00RSB0
16	IO41RSB2	52	IO07RSB0
17	IO40RSB2	53	IO03RSB0
18	IO39RSB1	54	IO18RSB1
19	IO37RSB1	55	IO20RSB1
20	IO35RSB1	56	IO22RSB1
21	IO33RSB1	57	IO24RSB1
22	IO31RSB1	58	IO28RSB1
23	IO30RSB1	59	NC
24	VCC	60	GND
25	GND	61	NC
26	VCCIB1	62	IO32RSB1
27	IO27RSB1	63	IO34RSB1
28	IO25RSB1	64	IO36RSB1
29	IO23RSB1	65	IO61RSB2
30	IO21RSB1	66	IO58RSB2
31	IO19RSB1	67	IO56RSB2
32	TCK	68	IO63RSB2
33	TDI		
34	TMS		
35	VPUMP		
36	TDO		

68-Pin QFN		68-Pin QFN	
Pin Number	A3PN020 Function	Pin Number	A3PN020 Function
1	IO60RSB2	36	TDO
2	IO54RSB2	37	TRST
3	IO52RSB2	38	VJTAG
4	IO50RSB2	39	IO17RSB0
5	IO49RSB2	40	IO16RSB0
6	GEC0/IO48RSB2	41	GDA0/IO15RSB0
7	GEA0/IO47RSB2	42	GDC0/IO14RSB0
8	VCC	43	IO13RSB0
9	GND	44	VCCIB0
10	VCCIB2	45	GND
11	IO46RSB2	46	VCC
12	IO45RSB2	47	IO12RSB0
13	IO44RSB2	48	IO11RSB0
14	IO43RSB2	49	IO09RSB0
15	IO42RSB2	50	IO05RSB0
16	IO41RSB2	51	IO00RSB0
17	IO40RSB2	52	IO07RSB0
18	IO39RSB1	53	IO03RSB0
19	IO37RSB1	54	IO18RSB1
20	IO35RSB1	55	IO20RSB1
21	IO33RSB1	56	IO22RSB1
22	IO31RSB1	57	IO24RSB1
23	IO30RSB1	58	IO28RSB1
24	VCC	59	NC
25	GND	60	GND
26	VCCIB1	61	NC
27	IO27RSB1	62	IO32RSB1
28	IO25RSB1	63	IO34RSB1
29	IO23RSB1	64	IO36RSB1
30	IO21RSB1	65	IO61RSB2
31	IO19RSB1	66	IO58RSB2
32	TCK	67	IO56RSB2
33	TDI	68	IO63RSB2
34	TMS		
35	VPUMP		

68-Pin QFN	
Pin Number	A3PN030Z Function
1	IO82RSB1
2	IO80RSB1
3	IO78RSB1
4	IO76RSB1
5	GEC0/IO73RSB1
6	GEA0/IO72RSB1
7	GEB0/IO71RSB1
8	VCC
9	GND
10	VCCIB1
11	IO68RSB1
12	IO67RSB1
13	IO66RSB1
14	IO65RSB1
15	IO64RSB1
16	IO63RSB1
17	IO62RSB1
18	IO60RSB1
19	IO58RSB1
20	IO56RSB1
21	IO54RSB1
22	IO52RSB1
23	IO51RSB1
24	VCC
25	GND
26	VCCIB1
27	IO50RSB1
28	IO48RSB1
29	IO46RSB1
30	IO44RSB1
31	IO42RSB1
32	TCK
33	TDI
34	TMS
35	VPUMP
36	TDO

68-Pin QFN	
Pin Number	A3PN030Z Function
37	TRST
38	VJTAG
39	IO40RSB0
40	IO37RSB0
41	GDB0/IO34RSB0
42	GDA0/IO33RSB0
43	GDC0/IO32RSB0
44	VCCIB0
45	GND
46	VCC
47	IO31RSB0
48	IO29RSB0
49	IO28RSB0
50	IO27RSB0
51	IO25RSB0
52	IO24RSB0
53	IO22RSB0
54	IO21RSB0
55	IO19RSB0
56	IO17RSB0
57	IO15RSB0
58	IO14RSB0
59	VCCIB0
60	GND
61	VCC
62	IO12RSB0
63	IO10RSB0
64	IO08RSB0
65	IO06RSB0
66	IO04RSB0
67	IO02RSB0
68	IO00RSB0

## 100-Pin VQFP

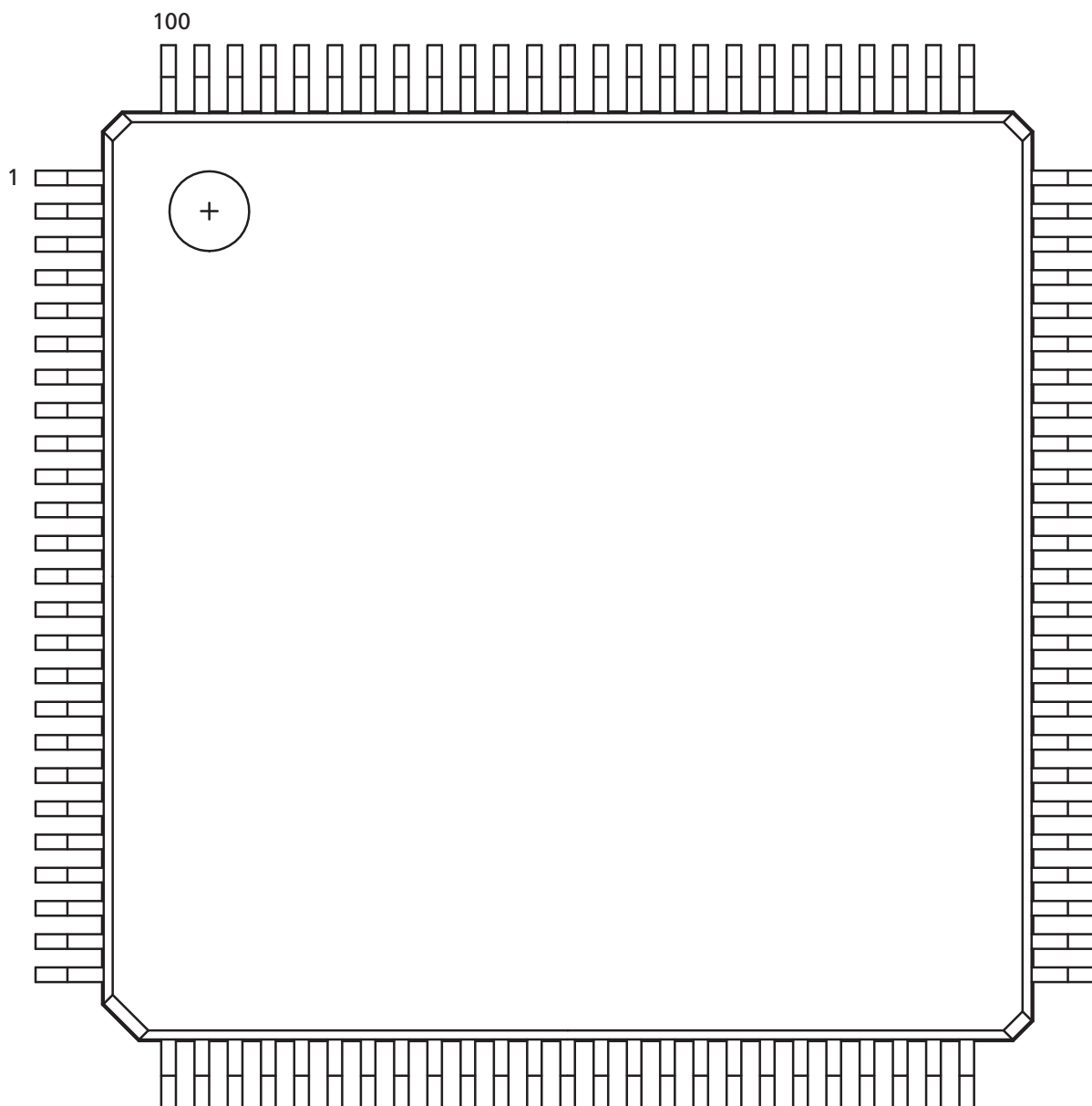

*Note:* This is the top view of the package.

### **Note**

For Package Manufacturing and Environmental information, visit the Resource Center at <http://www.actel.com/products/solutions/package/docs.aspx>.

100-Pin VQFP		100-Pin VQFP		100-Pin VQFP	
Pin Number	A3PN030Z Function	Pin Number	A3PN030Z Function	Pin Number	A3PN030Z Function
1	GND	36	IO51RSB1	71	IO29RSB0
2	IO82RSB1	37	VCC	72	IO28RSB0
3	IO81RSB1	38	GND	73	IO27RSB0
4	IO80RSB1	39	VCCIB1	74	IO26RSB0
5	IO79RSB1	40	IO49RSB1	75	IO25RSB0
6	IO78RSB1	41	IO47RSB1	76	IO24RSB0
7	IO77RSB1	42	IO46RSB1	77	IO23RSB0
8	IO76RSB1	43	IO45RSB1	78	IO22RSB0
9	GND	44	IO44RSB1	79	IO21RSB0
10	IO75RSB1	45	IO43RSB1	80	IO20RSB0
11	IO74RSB1	46	IO42RSB1	81	IO19RSB0
12	GEC0/IO73RSB1	47	TCK	82	IO18RSB0
13	GEA0/IO72RSB1	48	TDI	83	IO17RSB0
14	GEB0/IO71RSB1	49	TMS	84	IO16RSB0
15	IO70RSB1	50	NC	85	IO15RSB0
16	IO69RSB1	51	GND	86	IO14RSB0
17	VCC	52	VPUMP	87	VCCIB0
18	VCCIB1	53	NC	88	GND
19	IO68RSB1	54	TDO	89	VCC
20	IO67RSB1	55	TRST	90	IO12RSB0
21	IO66RSB1	56	VJTAG	91	IO10RSB0
22	IO65RSB1	57	IO41RSB0	92	IO08RSB0
23	IO64RSB1	58	IO40RSB0	93	IO07RSB0
24	IO63RSB1	59	IO39RSB0	94	IO06RSB0
25	IO62RSB1	60	IO38RSB0	95	IO05RSB0
26	IO61RSB1	61	IO37RSB0	96	IO04RSB0
27	IO60RSB1	62	IO36RSB0	97	IO03RSB0
28	IO59RSB1	63	GDB0/IO34RSB0	98	IO02RSB0
29	IO58RSB1	64	GDA0/IO33RSB0	99	IO01RSB0
30	IO57RSB1	65	GDC0/IO32RSB0	100	IO00RSB0
31	IO56RSB1	66	VCCIB0		
32	IO55RSB1	67	GND		
33	IO54RSB1	68	VCC		
34	IO53RSB1	69	IO31RSB0		
35	IO52RSB1	70	IO30RSB0		

100-Pin VQFP		100-Pin VQFP		100-Pin VQFP	
Pin Number	A3PN060 Function	Pin Number	A3PN060 Function	Pin Number	A3PN060 Function
1	GND	36	IO61RSB1	71	GBB2/IO27RSB0
2	GAA2/IO51RSB1	37	VCC	72	IO26RSB0
3	IO52RSB1	38	GND	73	GBA2/IO25RSB0
4	GAB2/IO53RSB1	39	VCCIB1	74	VMV0
5	IO95RSB1	40	IO60RSB1	75	GNDQ
6	GAC2/IO94RSB1	41	IO59RSB1	76	GBA1/IO24RSB0
7	IO93RSB1	42	IO58RSB1	77	GBA0/IO23RSB0
8	IO92RSB1	43	IO57RSB1	78	GBB1/IO22RSB0
9	GND	44	GDC2/IO56RSB1	79	GBB0/IO21RSB0
10	GFB1/IO87RSB1	45	GDB2/IO55RSB1	80	GBC1/IO20RSB0
11	GFB0/IO86RSB1	46	GDA2/IO54RSB1	81	GBC0/IO19RSB0
12	VCOMPLF	47	TCK	82	IO18RSB0
13	GFA0/IO85RSB1	48	TDI	83	IO17RSB0
14	VCCPLF	49	TMS	84	IO15RSB0
15	GFA1/IO84RSB1	50	VMV1	85	IO13RSB0
16	GFA2/IO83RSB1	51	GND	86	IO11RSB0
17	VCC	52	VPUMP	87	VCCIB0
18	VCCIB1	53	NC	88	GND
19	GEC1/IO77RSB1	54	TDO	89	VCC
20	GEB1/IO75RSB1	55	TRST	90	IO10RSB0
21	GEB0/IO74RSB1	56	VJTAG	91	IO09RSB0
22	GEA1/IO73RSB1	57	GDA1/IO49RSB0	92	IO08RSB0
23	GEA0/IO72RSB1	58	GDC0/IO46RSB0	93	GAC1/IO07RSB0
24	VMV1	59	GDC1/IO45RSB0	94	GAC0/IO06RSB0
25	GNDQ	60	GCC2/IO43RSB0	95	GAB1/IO05RSB0
26	GEA2/IO71RSB1	61	GCB2/IO42RSB0	96	GAB0/IO04RSB0
27	GEB2/IO70RSB1	62	GCA0/IO40RSB0	97	GAA1/IO03RSB0
28	GEC2/IO69RSB1	63	GCA1/IO39RSB0	98	GAA0/IO02RSB0
29	IO68RSB1	64	GCC0/IO36RSB0	99	IO01RSB0
30	IO67RSB1	65	GCC1/IO35RSB0	100	IO00RSB0
31	IO66RSB1	66	VCCIB0		
32	IO65RSB1	67	GND		
33	IO64RSB1	68	VCC		
34	IO63RSB1	69	IO31RSB0		
35	IO62RSB1	70	GBC2/IO29RSB0		

100-Pin VQFP		100-Pin VQFP		100-Pin VQFP	
Pin Number	A3PN060Z	Pin Number	A3PN060Z	Pin Number	A3PN060Z
1	GND	36	IO61RSB1	71	GBB2/IO27RSB0
2	GAA2/IO51RSB1	37	VCC	72	IO26RSB0
3	IO52RSB1	38	GND	73	GBA2/IO25RSB0
4	GAB2/IO53RSB1	39	VCCIB1	74	VMV0
5	IO95RSB1	40	IO60RSB1	75	GNDQ
6	GAC2/IO94RSB1	41	IO59RSB1	76	GBA1/IO24RSB0
7	IO93RSB1	42	IO58RSB1	77	GBA0/IO23RSB0
8	IO92RSB1	43	IO57RSB1	78	GBB1/IO22RSB0
9	GND	44	GDC2/IO56RSB1	79	GBB0/IO21RSB0
10	GFB1/IO87RSB1	45	GDB2/IO55RSB1	80	GBC1/IO20RSB0
11	GFB0/IO86RSB1	46	GDA2/IO54RSB1	81	GBC0/IO19RSB0
12	VCOMPLF	47	TCK	82	IO18RSB0
13	GFA0/IO85RSB1	48	TDI	83	IO17RSB0
14	VCCPLF	49	TMS	84	IO15RSB0
15	GFA1/IO84RSB1	50	VMV1	85	IO13RSB0
16	GFA2/IO83RSB1	51	GND	86	IO11RSB0
17	VCC	52	VPUMP	87	VCCIB0
18	VCCIB1	53	NC	88	GND
19	GEC1/IO77RSB1	54	TDO	89	VCC
20	GEB1/IO75RSB1	55	TRST	90	IO10RSB0
21	GEB0/IO74RSB1	56	VJTAG	91	IO09RSB0
22	GEA1/IO73RSB1	57	GDA1/IO49RSB0	92	IO08RSB0
23	GEA0/IO72RSB1	58	GDC0/IO46RSB0	93	GAC1/IO07RSB0
24	VMV1	59	GDC1/IO45RSB0	94	GAC0/IO06RSB0
25	GNDQ	60	GCC2/IO43RSB0	95	GAB1/IO05RSB0
26	GEA2/IO71RSB1	61	GCB2/IO42RSB0	96	GAB0/IO04RSB0
27	GEB2/IO70RSB1	62	GCA0/IO40RSB0	97	GAA1/IO03RSB0
28	GEC2/IO69RSB1	63	GCA1/IO39RSB0	98	GAA0/IO02RSB0
29	IO68RSB1	64	GCC0/IO36RSB0	99	IO01RSB0
30	IO67RSB1	65	GCC1/IO35RSB0	100	IO00RSB0
31	IO66RSB1	66	VCCIB0		
32	IO65RSB1	67	GND		
33	IO64RSB1	68	VCC		
34	IO63RSB1	69	IO31RSB0		
35	IO62RSB1	70	GBC2/IO29RSB0		

100-Pin VQFP		100-Pin VQFP		100-Pin VQFP	
Pin Number	A3PN125 Function	Pin Number	A3PN125 Function	Pin Number	A3PN125 Function
1	GND	36	IO93RSB1	71	GBB2/IO43RSB0
2	GAA2/IO67RSB1	37	VCC	72	IO42RSB0
3	IO68RSB1	38	GND	73	GBA2/IO41RSB0
4	GAB2/IO69RSB1	39	VCCIB1	74	VMV0
5	IO132RSB1	40	IO87RSB1	75	GNDQ
6	GAC2/IO131RSB1	41	IO84RSB1	76	GBA1/IO40RSB0
7	IO130RSB1	42	IO81RSB1	77	GBA0/IO39RSB0
8	IO129RSB1	43	IO75RSB1	78	GBB1/IO38RSB0
9	GND	44	GDC2/IO72RSB1	79	GBB0/IO37RSB0
10	GFB1/IO124RSB1	45	GDB2/IO71RSB1	80	GBC1/IO36RSB0
11	GFB0/IO123RSB1	46	GDA2/IO70RSB1	81	GBC0/IO35RSB0
12	VCOMPLF	47	TCK	82	IO32RSB0
13	GFA0/IO122RSB1	48	TDI	83	IO28RSB0
14	VCCPLF	49	TMS	84	IO25RSB0
15	GFA1/IO121RSB1	50	VMV1	85	IO22RSB0
16	GFA2/IO120RSB1	51	GND	86	IO19RSB0
17	VCC	52	VPUMP	87	VCCIB0
18	VCCIB1	53	NC	88	GND
19	GEC0/IO111RSB1	54	TDO	89	VCC
20	GEB1/IO110RSB1	55	TRST	90	IO15RSB0
21	GEB0/IO109RSB1	56	VJTAG	91	IO13RSB0
22	GEA1/IO108RSB1	57	GDA1/IO65RSB0	92	IO11RSB0
23	GEA0/IO107RSB1	58	GDC0/IO62RSB0	93	IO09RSB0
24	VMV1	59	GDC1/IO61RSB0	94	IO07RSB0
25	GNDQ	60	GCC2/IO59RSB0	95	GAC1/IO05RSB0
26	GEA2/IO106RSB1	61	GCB2/IO58RSB0	96	GAC0/IO04RSB0
27	GEB2/IO105RSB1	62	GCA0/IO56RSB0	97	GAB1/IO03RSB0
28	GEC2/IO104RSB1	63	GCA1/IO55RSB0	98	GAB0/IO02RSB0
29	IO102RSB1	64	GCC0/IO52RSB0	99	GAA1/IO01RSB0
30	IO100RSB1	65	GCC1/IO51RSB0	100	GAA0/IO00RSB0
31	IO99RSB1	66	VCCIB0		
32	IO97RSB1	67	GND		
33	IO96RSB1	68	VCC		
34	IO95RSB1	69	IO47RSB0		
35	IO94RSB1	70	GBC2/IO45RSB0		

100-Pin VQFP		100-Pin VQFP		100-Pin VQFP	
Pin Number	A3PN125Z Function	Pin Number	A3PN125Z Function	Pin Number	A3PN125Z Function
1	GND	36	IO93RSB1	71	GBB2/IO43RSB0
2	GAA2/IO67RSB1	37	VCC	72	IO42RSB0
3	IO68RSB1	38	GND	73	GBA2/IO41RSB0
4	GAB2/IO69RSB1	39	VCCIB1	74	VMV0
5	IO132RSB1	40	IO87RSB1	75	GNDQ
6	GAC2/IO131RSB1	41	IO84RSB1	76	GBA1/IO40RSB0
7	IO130RSB1	42	IO81RSB1	77	GBA0/IO39RSB0
8	IO129RSB1	43	IO75RSB1	78	GBB1/IO38RSB0
9	GND	44	GDC2/IO72RSB1	79	GBB0/IO37RSB0
10	GFB1/IO124RSB1	45	GDB2/IO71RSB1	80	GBC1/IO36RSB0
11	GFB0/IO123RSB1	46	GDA2/IO70RSB1	81	GBC0/IO35RSB0
12	VCOMPLF	47	TCK	82	IO32RSB0
13	GFA0/IO122RSB1	48	TDI	83	IO28RSB0
14	VCCPLF	49	TMS	84	IO25RSB0
15	GFA1/IO121RSB1	50	VMV1	85	IO22RSB0
16	GFA2/IO120RSB1	51	GND	86	IO19RSB0
17	VCC	52	VPUMP	87	VCCIB0
18	VCCIB1	53	NC	88	GND
19	GEC0/IO111RSB1	54	TDO	89	VCC
20	GEB1/IO110RSB1	55	TRST	90	IO15RSB0
21	GEB0/IO109RSB1	56	VJTAG	91	IO13RSB0
22	GEA1/IO108RSB1	57	GDA1/IO65RSB0	92	IO11RSB0
23	GEA0/IO107RSB1	58	GDC0/IO62RSB0	93	IO09RSB0
24	VMV1	59	GDC1/IO61RSB0	94	IO07RSB0
25	GNDQ	60	GCC2/IO59RSB0	95	GAC1/IO05RSB0
26	GEA2/IO106RSB1	61	GCB2/IO58RSB0	96	GAC0/IO04RSB0
27	GEB2/IO105RSB1	62	GCA0/IO56RSB0	97	GAB1/IO03RSB0
28	GEC2/IO104RSB1	63	GCA1/IO55RSB0	98	GAB0/IO02RSB0
29	IO102RSB1	64	GCC0/IO52RSB0	99	GAA1/IO01RSB0
30	IO100RSB1	65	GCC1/IO51RSB0	100	GAA0/IO00RSB0
31	IO99RSB1	66	VCCIB0		
32	IO97RSB1	67	GND		
33	IO96RSB1	68	VCC		
34	IO95RSB1	69	IO47RSB0		
35	IO94RSB1	70	GBC2/IO45RSB0		

100-Pin VQFP		100-Pin VQFP		100-Pin VQFP	
Pin Number	A3PN250 Function	Pin Number	A3PN250 Function	Pin Number	A3PN250 Function
1	GND	37	VCC	73	GBA2/IO20RSB1
2	GAA2/IO67RSB3	38	GND	74	VMV1
3	IO66RSB3	39	VCCIB2	75	GNDQ
4	GAB2/IO65RSB3	40	IO39RSB2	76	GBA1/IO19RSB0
5	IO64RSB3	41	IO38RSB2	77	GBA0/IO18RSB0
6	GAC2/IO63RSB3	42	IO37RSB2	78	GBB1/IO17RSB0
7	IO62RSB3	43	GDC2/IO36RSB2	79	GBB0/IO16RSB0
8	IO61RSB3	44	GDB2/IO35RSB2	80	GBC1/IO15RSB0
9	GND	45	GDA2/IO34RSB2	81	GBC0/IO14RSB0
10	GFB1/IO60RSB3	46	GNDQ	82	IO13RSB0
11	GFB0/IO59RSB3	47	TCK	83	IO12RSB0
12	VCOMPLF	48	TDI	84	IO11RSB0
13	GFA0/IO57RSB3	49	TMS	85	IO10RSB0
14	VCCPLF	50	VMV2	86	IO09RSB0
15	GFA1/IO58RSB3	51	GND	87	VCCIB0
16	GFA2/IO56RSB3	52	VPUMP	88	GND
17	VCC	53	NC	89	VCC
18	VCCIB3	54	TDO	90	IO08RSB0
19	GFC2/IO55RSB3	55	TRST	91	IO07RSB0
20	GEC1/IO54RSB3	56	VJTAG	92	IO06RSB0
21	GEC0/IO53RSB3	57	GDA1/IO33RSB1	93	GAC1/IO05RSB0
22	GEA1/IO52RSB3	58	GDC0/IO32RSB1	94	GAC0/IO04RSB0
23	GEA0/IO51RSB3	59	GDC1/IO31RSB1	95	GAB1/IO03RSB0
24	VMV3	60	IO30RSB1	96	GAB0/IO02RSB0
25	GNDQ	61	GCB2/IO29RSB1	97	GAA1/IO01RSB0
26	GEA2/IO50RSB2	62	GCA1/IO27RSB1	98	GAA0/IO00RSB0
27	GEB2/IO49RSB2	63	GCA0/IO28RSB1	99	GNDQ
28	GEC2/IO48RSB2	64	GCC0/IO26RSB1	100	VMV0
29	IO47RSB2	65	GCC1/IO25RSB1		
30	IO46RSB2	66	VCCIB1		
31	IO45RSB2	67	GND		
32	IO44RSB2	68	VCC		
33	IO43RSB2	69	IO24RSB1		
34	IO42RSB2	70	GBC2/IO23RSB1		
35	IO41RSB2	71	GBB2/IO22RSB1		
36	IO40RSB2	72	IO21RSB1		

100-Pin VQFP	
Pin Number	A3PN250Z Function
1	GND
2	GAA2/IO67RSB3
3	IO66RSB3
4	GAB2/IO65RSB3
5	IO64RSB3
6	GAC2/IO63RSB3
7	IO62RSB3
8	IO61RSB3
9	GND
10	GFB1/IO60RSB3
11	GFB0/IO59RSB3
12	VCOMPLF
13	GFA0/IO57RSB3
14	VCCPLF
15	GFA1/IO58RSB3
16	GFA2/IO56RSB3
17	VCC
18	VCCIB3
19	GFC2/IO55RSB3
20	GEC1/IO54RSB3
21	GEC0/IO53RSB3
22	GEA1/IO52RSB3
23	GEA0/IO51RSB3
24	VMV3
25	GNDQ
26	GEA2/IO50RSB2
27	GEB2/IO49RSB2
28	GEC2/IO48RSB2
29	IO47RSB2
30	IO46RSB2
31	IO45RSB2
32	IO44RSB2
33	IO43RSB2
34	IO42RSB2
35	IO41RSB2
36	IO40RSB2

100-Pin VQFP	
Pin Number	A3PN250Z Function
37	VCC
38	GND
39	VCCIB2
40	IO39RSB2
41	IO38RSB2
42	IO37RSB2
43	GDC2/IO36RSB2
44	GDB2/IO35RSB2
45	GDA2/IO34RSB2
46	GNDQ
47	TCK
48	TDI
49	TMS
50	VMV2
51	GND
52	VPUMP
53	NC
54	TDO
55	TRST
56	VJTAG
57	GDA1/IO33RSB1
58	GDC0/IO32RSB1
59	GDC1/IO31RSB1
60	IO30RSB1
61	GCB2/IO29RSB1
62	GCA1/IO27RSB1
63	GCA0/IO28RSB1
64	GCC0/IO26RSB1
65	GCC1/IO25RSB1
66	VCCIB1
67	GND
68	VCC
69	IO24RSB1
70	GBC2/IO23RSB1
71	GBB2/IO22RSB1
72	IO21RSB1

100-Pin VQFP	
Pin Number	A3PN250Z Function
73	GBA2/IO20RSB1
74	VMV1
75	GNDQ
76	GBA1/IO19RSB0
77	GBA0/IO18RSB0
78	GBB1/IO17RSB0
79	GBB0/IO16RSB0
80	GBC1/IO15RSB0
81	GBC0/IO14RSB0
82	IO13RSB0
83	IO12RSB0
84	IO11RSB0
85	IO10RSB0
86	IO09RSB0
87	VCCIB0
88	GND
89	VCC
90	IO08RSB0
91	IO07RSB0
92	IO06RSB0
93	GAC1/IO05RSB0
94	GAC0/IO04RSB0
95	GAB1/IO03RSB0
96	GAB0/IO02RSB0
97	GAA1/IO01RSB0
98	GAA0/IO00RSB0
99	GNDQ
100	VMV0



## 4 – Datasheet Information

### List of Changes

The following table lists critical changes that were made in the current version of the ProASIC3 nano datasheet.

Revision	Changes	Page
Revision 8 (April 2010)	References to differential inputs were removed from the datasheet, since ProASIC3 nano devices do not support differential inputs (SAR 21449).	N/A
	The "ProASIC3 nano Device Status" table is new.	II
	The JTAG DC voltage was revised in <a href="#">Table 2-2 • Recommended Operating Conditions 1, 2</a> (SAR 24052). The maximum value for VPUMP programming voltage (operation mode) was changed from 3.45 V to 3.6 V (SAR 25220).	2-2
	The highest temperature in <a href="#">Table 2-6 • Temperature and Voltage Derating Factors for Timing Delays</a> was changed to 100°C.	2-5
	The typical value for A3PN010 was revised in <a href="#">Table 2-7 • Quiescent Supply Current Characteristics</a> . The note was revised to remove the statement that values do not include I/O static contribution.	2-6
	The following tables were updated with available information: <a href="#">Table 2-8 • Summary of I/O Input Buffer Power (Per Pin) – Default I/O Software Settings</a> <a href="#">Table 2-9 • Summary of I/O Output Buffer Power (per pin) – Default I/O Software Settings</a> <a href="#">Table 2-10 • Different Components Contributing to Dynamic Power Consumption in ProASIC3 nano Devices</a> <a href="#">Table 2-14 • Summary of Maximum and Minimum DC Input and Output Levels</a> <a href="#">Table 2-18 • Summary of I/O Timing Characteristics—Software Default Settings (at 35 pF)</a> <a href="#">Table 2-19 • Summary of I/O Timing Characteristics—Software Default Settings (at 10 pF)</a>	2-6 through 2-18
	<a href="#">Table 2-22 • I/O Weak Pull-Up/Pull-Down Resistances</a> was revised to add wide range data and correct the formulas in the table notes (SAR 21348).	2-19
	The text introducing <a href="#">Table 2-24 • Duration of Short Circuit Event before Failure</a> was revised to state six months at 100° instead of three months at 110° for reliability concerns. The row for 110° was removed from the table.	2-20
	<a href="#">Table 2-26 • I/O Input Rise Time, Fall Time, and Related I/O Reliability</a> was revised to give values with Schmitt trigger disabled and enabled (SAR 24634). The temperature for reliability was changed to 100°C.	2-21
	<a href="#">Table 2-33 • Minimum and Maximum DC Input and Output Levels for 3.3 V LVCMOS Wide Range</a> and the timing tables in the "Single-Ended I/O Characteristics" section were updated with available information. The timing tables for 3.3 V LVCMOS wide range are new.	2-22
	The following sentence was deleted from the "2.5 V LVCMOS" section: "It uses a 5 V-tolerant input buffer and push-pull output buffer."	2-30

Revision	Changes	Page
Revision 8 (continued)	Values for $t_{DDRISUD}$ and $F_{DDRIMAX}$ were updated in <a href="#">Table 2-62 • Input DDR Propagation Delays</a> . Values for $F_{DDOMAX}$ were added to <a href="#">Table 2-64 • Output DDR Propagation Delays (SAR 23919)</a> .	2-46, 2-48
	<a href="#">Table 2-67 • A3PN010 Global Resource</a> through <a href="#">Table 2-70 • A3PN060 Global Resource</a> were updated with available information.	2-54 through 2-55
	<a href="#">Table 2-73 • ProASIC3 nano CCC/PLL Specification</a> was revised (SAR 79390).	2-57
Revision 7 (January 2010)	All product tables and pin tables were updated to show clearly that A3PN030 is available only in the Z feature at this time, as A3PN030Z. The nano-Z feature grade devices are designated with a Z at the end of the part number.	N/A
	The "68-Pin QFN" and "100-Pin VQFP" pin tables for A3PN030 were removed. Only the Z grade for A3PN030 is available at this time.	N/A
Revision 6 (August 2009)	The note for A3PN030 in the " <a href="#">ProASIC3 nano Devices</a> " table was revised. It states A3PN030 is available in the Z feature grade only.	I
Revision 5 (March 2009)	The "68-Pin QFN" pin table for A3PN030 is new.	3-7
	The "48-Pin QFN", "68-Pin QFN", and "100-Pin VQFP" pin tables for A3PN030Z are new.	3-3, 3-7, 3-9
	The "100-Pin VQFP" pin table for A3PN060Z is new.	3-11
	The "100-Pin VQFP" pin table for A3PN125Z is new	3-13
	The "100-Pin VQFP" pin table for A3PN250Z is new.	3-15
Revision 4 (February 2009)	The "100-Pin VQFP" pin table for A3PN030 is new.	3-10
Revision 3 (February 2009)	All references to speed grade –F were removed from this document.	N/A
	The " <a href="#">I/Os with Advanced I/O Standards</a> " section was revised to add definitions of hot-swap and cold-sparing.	1-7
	The "100-Pin VQFP" pin table for A3PN030 is new.	3-10
Revision 2 (November 2008)	The " <a href="#">ProASIC3 nano Devices</a> " table was revised to change the maximum user I/Os for A3PN020 and A3PN030. The following table note was removed: "Six chip (main) and three quadrant global networks are available for A3PN060 and above."	I
	The QN100 package was removed for all devices.	N/A
	The " <a href="#">Device Marking</a> " section is new.	III
	The "100-Pin QFN" section was removed.	N/A
Revision 1 (October 2008)	The A3PN030 device was added to product tables and replaces A3P030 entries that were formerly in the tables.	I to IV
	The " <a href="#">Wide Range I/O Support</a> " section is new.	1-7
	The " <a href="#">I/Os Per Package</a> " table was updated to add the following information to table note 4: "For nano devices, the VQ100 package is offered in both leaded and RoHS-compliant versions. All other packages are RoHS-compliant only."	II
	The " <a href="#">ProASIC3 nano Product Available in the Z Feature Grade</a> " section was updated to remove QN100 for A3PN250.	IV
	The " <a href="#">General Description</a> " section was updated to give correct information about number of gates and dual-port RAM for ProASIC3 nano devices.	1-1

Revision	Changes	Page
Revision 1 (continued)	The device architecture figures, Figure 1-3 • ProASIC3 nano Device Architecture Overview with Two I/O Banks (A3PN060 and A3PN125) through Figure 1-4 • ProASIC3 nano Device Architecture Overview with Four I/O Banks (A3PN250), were revised. Figure 1-1 • ProASIC3 Device Architecture Overview with Two I/O Banks and No RAM (A3PN010 and A3PN030) is new.	1-3 through 1-4
	The "PLL and CCC" section was revised to include information about CCC-GLs in A3PN020 and smaller devices.	1-6
	Table 2-2 • Recommended Operating Conditions 1, 2 was revised to add VMV to the VCCI row. The following table note was added: "VMV pins must be connected to the corresponding VCCI pins."	2-2
	The values in Table 2-7 • Quiescent Supply Current Characteristics were revised for A3PN010, A3PN015, and A3PN020.	2-6
	A table note, "All LVCMOS 3.3 V software macros support LVCMOS 3.3 V wide range, as specified in the JESD8-B specification," was added to Table 2-14 • Summary of Maximum and Minimum DC Input and Output Levels, Table 2-18 • Summary of I/O Timing Characteristics—Software Default Settings (at 35 pF), and Table 2-19 • Summary of I/O Timing Characteristics—Software Default Settings (at 10 pF).	2-16, 2-18
	3.3 V LVCMOS Wide Range was added to Table 2-21 • I/O Output Buffer Maximum Resistances 1 and Table 2-23 • I/O Short Currents IOSH/IOSL.	2-19, 2-20
	The "48-Pin QFN" pin diagram was revised.	3-2
	Note 2 for the "48-Pin QFN", "68-Pin QFN", and "100-Pin VQFP" pin diagrams was added/changed to "The die attach paddle of the package is tied to ground (GND)."	3-2, 3-5, 3-9
	The "100-Pin VQFP" pin diagram was revised to move the pin IDs to the upper left corner instead of the upper right corner.	3-9

## Datasheet Categories

### **Categories**

In order to provide the latest information to designers, some datasheet parameters are published before data has been fully characterized from silicon devices. The data provided for a given device, as highlighted in the "ProASIC3 nano Device Status" table on page II, is designated as either "Product Brief," "Advance," "Preliminary," or "Production." The definitions of these categories are as follows:

### **Product Brief**

The product brief is a summarized version of a datasheet (advance or production) and contains general product information. This document gives an overview of specific device and family information.

### **Advance**

This version contains initial estimated information based on simulation, other products, devices, or speed grades. This information can be used as estimates, but not for production. This label only applies to the DC and Switching Characteristics chapter of the datasheet and will only be used when the data has not been fully characterized.

### **Preliminary**

The datasheet contains information based on simulation and/or initial characterization. The information is believed to be correct, but changes are possible.

### **Unmarked (production)**

This version contains information that is considered to be final.

## **Export Administration Regulations (EAR)**

The products described in this document are subject to the Export Administration Regulations (EAR). They could require an approved export license prior to export from the United States. An export includes release of product or disclosure of technology to a foreign national inside or outside the United States.

## **Actel Safety Critical, Life Support, and High-Reliability Applications Policy**

The Actel products described in this advance status document may not have completed Actel's qualification process. Actel may amend or enhance products during the product introduction and qualification process, resulting in changes in device functionality or performance. It is the responsibility of each customer to ensure the fitness of any Actel product (but especially a new product) for a particular purpose, including appropriateness for safety-critical, life-support, and other high-reliability applications. Consult Actel's Terms and Conditions for specific liability exclusions relating to life-support applications. A reliability report covering all of Actel's products is available on the Actel website at [http://www.actel.com/documents/ORT\\_Report.pdf](http://www.actel.com/documents/ORT_Report.pdf). Actel also offers a variety of enhanced qualification and lot acceptance screening procedures. Contact your local Actel sales office for additional reliability information.





**Actel is the leader in low power FPGAs and mixed signal FPGAs and offers the most comprehensive portfolio of system and power management solutions. Power Matters. Learn more at [www.actel.com](http://www.actel.com).**

**Actel Corporation**

2061 Stierlin Court  
Mountain View, CA  
94043-4655 USA  
**Phone** 650.318.4200  
**Fax** 650.318.4600

**Actel Europe Ltd.**

River Court, Meadows Business Park  
Station Approach, Blackwater  
Camberley Surrey GU17 9AB  
United Kingdom  
**Phone** +44 (0) 1276 609 300  
**Fax** +44 (0) 1276 607 540

**Actel Japan**

EXOS Ebisu Building 4F  
1-24-14 Ebisu Shibuya-ku  
Tokyo 150 Japan  
**Phone** +81.03.3445.7671  
**Fax** +81.03.3445.7668  
<http://jp.actel.com>

**Actel Hong Kong**

Room 2107, China Resources Building  
26 Harbour Road  
Wanchai, Hong Kong  
**Phone** +852 2185 6460  
**Fax** +852 2185 6488  
[www.actel.com.cn](http://www.actel.com.cn)