

THIS DRAWING IS UNPUBLISHED. RELEASED FOR PUBLICATION JUNE ,2004.  
 © COPYRIGHT 2004 BY TYCO ELECTRONICS CORPORATION. ALL RIGHTS RESERVED.

| LOC | DIST | REVISIONS |     |               |           |      |      |
|-----|------|-----------|-----|---------------|-----------|------|------|
| E   | B    | P         | LTR | DESCRIPTION   | DATE      | DWN  | APVD |
|     |      | D         |     | ECO-09-022031 | 29 SEP 09 | RITA | BOB  |

- NOTES**
- 1 SINGLE PACK IN ACCORDANCE WITH AMP SPEC 107-3275
  - 2 100 TRAY PACK IN ACCORDANCE WITH AMP SPEC 107-3275
  - 3 Au PLATING OVER Ni PLATING OVER Cu PLATING
  - 4 Ni PLATING OVER Cu PLATING
  5. HAND TOOL: 9-1478240-0
  6. DIE SET: SEE TABLE
  7. FOR TECHNICAL DATA REFER TO YOUR LOCAL TYCO ELECTRONICS SALES OFFICE
  8. ALL DIMENSIONS ARE NOMINAL FOR REFERENCE ONLY UNLESS OTHERWISE STATED

|            |  |     |     |     |      |     |             |   |              |
|------------|--|-----|-----|-----|------|-----|-------------|---|--------------|
|            |  | -   | -   | 0.4 | 4.5  | 3.1 | 9-1478242-0 | RG179B/U, 187A/U, URM111  | 5-1634502-5  |
|            |  | -   | -   | 0.4 | 4.5  | 3.1 | 9-1478242-0 | RG179B/U, 187A/U, URM111  | 5-1634502-4  |
|            |  | 7.5 | 6.6 | 0.7 | 5.45 | 3.8 | 9-1478242-0 | RG59B/U, 62A/U, 140/U, 210/U, URM90, KX 6A, KX 25, KX 52, KX 53 | 5-1634502-3  |
|            |  | 7.5 | 6.6 | 0.7 | 5.45 | 3.8 | 9-1478242-0 | RG59B/U, 62A/U, 140/U, 210/U, URM90, KX 6A, KX 25, KX 52, KX 53 | 5-1634502-2  |
|            |  | 6.4 | 5.4 | 0.7 | 4.5  | 3.1 | 9-1478242-0 | E4205, NEK23795, SDTV-A-LFH, 36-516/519, IMAGE360, RA7000       | 5-1634502-1  |
|            |  | 6.4 | 5.4 | 0.7 | 4.5  | 3.1 | 9-1478242-0 | E4205, NEK23795, SDTV-A-LFH, 36-516/519, IMAGE360, RA7000       | 5-1634502-0  |
|            |  | E   | D   | C   | B    | A   | DIE SET     |   | CABLE GROUPS |
| DIMENSIONS |  |     |     |     |      |     |             |   |              |

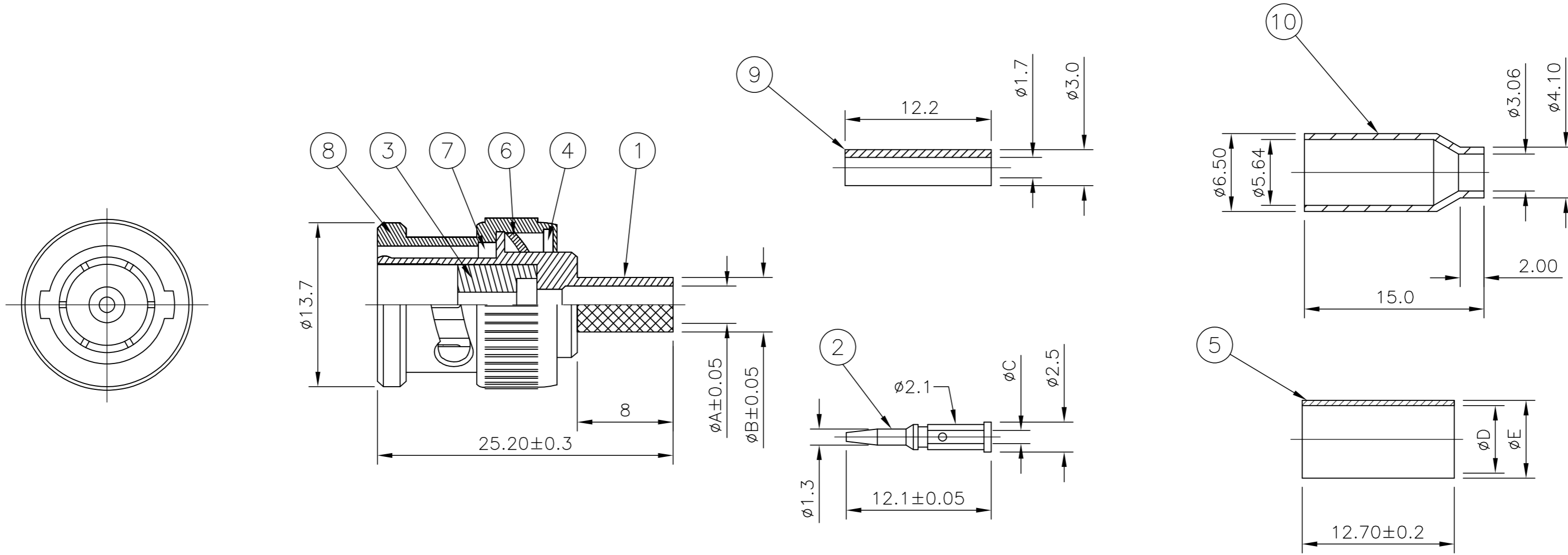

| QTY | 1 | 1 | - | - | - | - | MATERIAL          | DESCRIPTION   | ITEM |
|-----|---|---|---|---|---|---|-------------------|---------------|------|
|     | 1 | 1 | - | - | - | - | BRASS             | CRIMP SLEEVE  | 10   |
|     | 1 | 1 | - | - | - | - | NYLON             | PUSHER SLEEVE | 9    |
|     | 1 | 1 | 1 | 1 | 1 | 1 | ZINC ALLOY        | BARREL        | 8    |
|     | 1 | 1 | 1 | 1 | 1 | 1 | SILCON RUBBER     | GASKET        | 7    |
|     | 1 | 1 | 1 | 1 | 1 | 1 | SPRING STEEL      | SPRING        | 6    |
|     | - | - | 1 | 1 | 1 | 1 | BRASS             | CRIMP SLEEVE  | 5    |
|     | 1 | 1 | 1 | 1 | 1 | 1 | IRON              | WASHER        | 4    |
|     | 1 | 1 | 1 | 1 | 1 | 1 | POLYMETHYLPENTENE | INSULATOR     | 3    |
|     | 1 | 1 | 1 | 1 | 1 | 1 | BRASS             | CONTACT       | 2    |
|     | 1 | 1 | 1 | 1 | 1 | 1 | ZINC ALLOY        | BODY          | 1    |
|     | 5 | 5 | 4 | 5 | 3 | 5 | MATERIAL          | DESCRIPTION   | ITEM |

|   |  |                                 |  |                    |
|---|--|---------------------------------|--|--------------------|
| THIS DRAWING IS A CONTROLLED DOCUMENT.  |  | DWN<br>RITA ZUO<br>19 Feb 09    | Tyco Electronics Corporation<br>Kunshan, Jiangsu, PRC 215312 |                    |
| DIMENSIONS:<br>MM   |  | CHK<br>ANSON MA<br>19 Feb 09    | NAME<br>BNC STRAIGHT PLUG HEX CRIMP<br>75 OHM                |                    |
| TOLERANCES UNLESS OTHERWISE SPECIFIED:<br>0 PLC ± 0.5<br>1 PLC ± 0.3<br>2 PLC ± 0.2<br>3 PLC ± -<br>4 PLC ± -<br>ANGLES ± - |  | APVD<br>BOB ZHAO<br>19 Feb 09   | RESTRICTED TO  |                    |
| MATERIAL<br>SEE TABLE   |  | PRODUCT SPEC<br>108-112000      | SIZE<br>A2   | CAGE CODE<br>00779 |
| FINISH<br>SEE TABLE   |  | APPLICATION SPEC<br>SEE SHEET 2 | DRAWING NO<br>C=1634502                                      |                    |
|   |  | WEIGHT<br>-                     | SCALE<br>NTS   | SHEET<br>1 OF 2    |
|   |  | CUSTOMER DRAWING                |  | REV<br>D           |

THIS DRAWING IS UNPUBLISHED. RELEASED FOR PUBLICATION JUNE ,2004.  
 © COPYRIGHT 2004 BY TYCO ELECTRONICS CORPORATION. ALL RIGHTS RESERVED.

| LOC |     | DIST        |      | REVISIONS |      |  |  |
|-----|-----|-------------|------|-----------|------|--|--|
| P   | LTR | DESCRIPTION | DATE | DWN       | APVD |  |  |
| -   | -   | SEE SHEET 1 | -    | -         | -    |  |  |

COMPONENTS

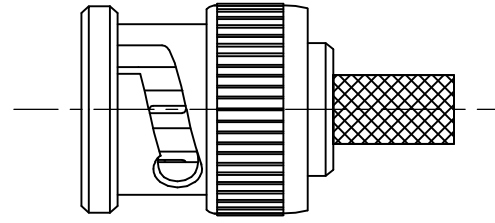
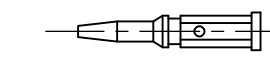
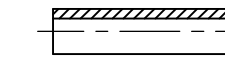
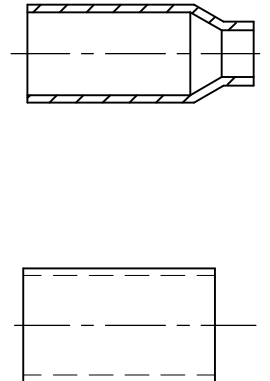
| MAIN BODY<br>(ITEM 1,3,4,6,7 & 8)   | CENTRE CONTACT<br>(ITEM 2)  | PUSHER SLEEVE<br>(ITEM 9)   | CRIMP FERRULES<br>(ITEM 5 & 10)   |
|---|---|---|---|
|  |  |  |  |

ASSEMBLY INSTRUCTION

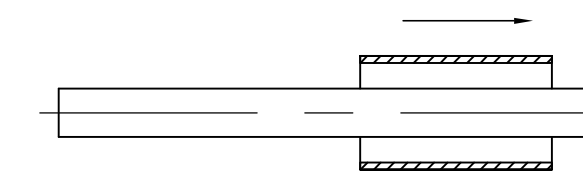
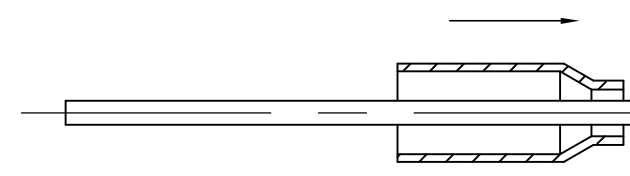
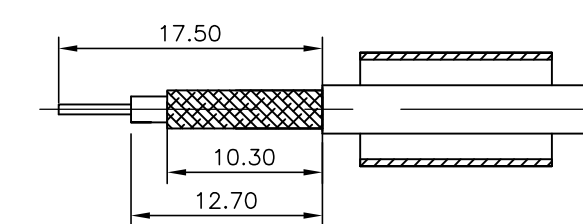
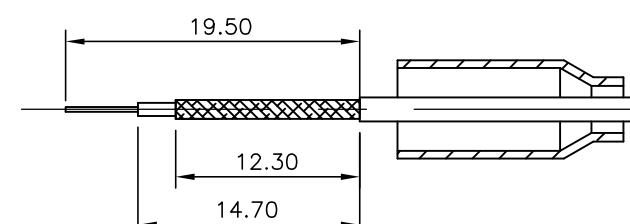
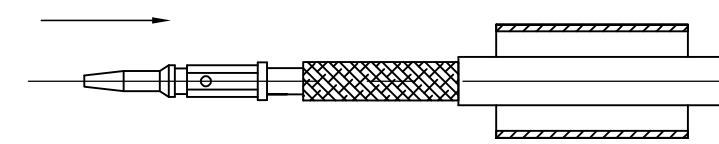
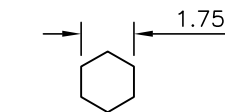
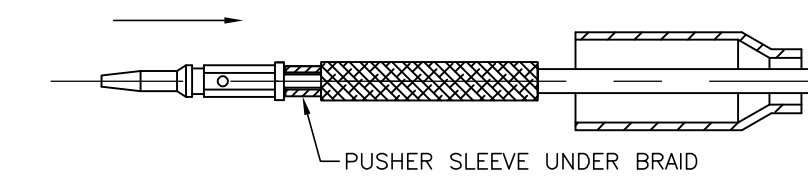
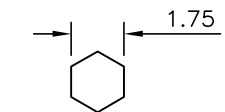
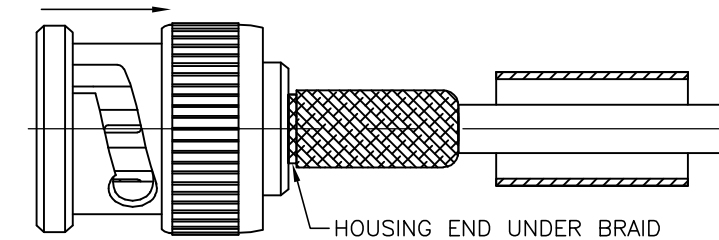
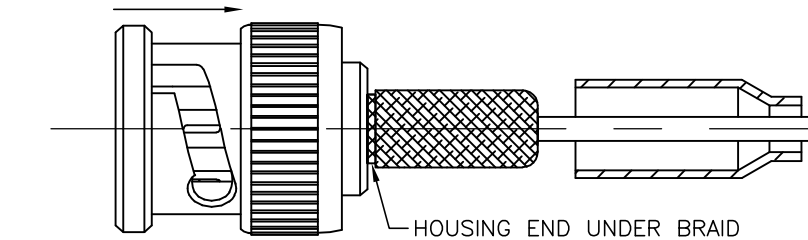
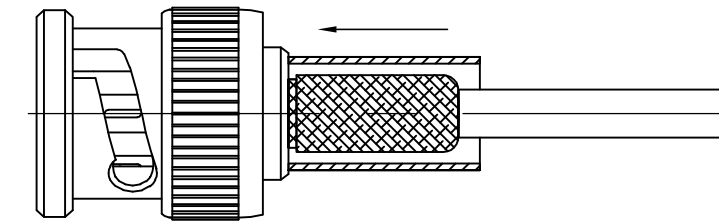
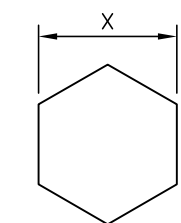
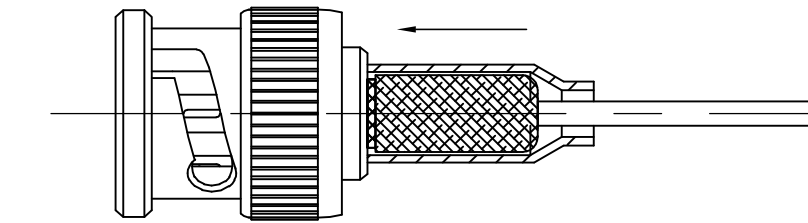
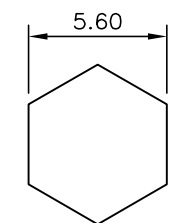
| CABLES: RG59B/U, 62A/U, 140/U, 210/U, URM90, KX 6A, KX 25, KX 52, KX 53, RG58C/U, 141A/U, URM43, 76, BELDEN 9907, KX 15  | CABLES: RG179B/U, 187A/U, URM111  |
|--|---|
| <p><b>STEP 1</b></p> <p>1. SLIDE METAL CRIMP FERRULE OVER CABLE</p>    | <p><b>STEP 1</b></p> <p>1. SLIDE METAL CRIMP FERRULE OVER CABLE</p>    |
| <p><b>STEP 2</b></p> <p>1. STRIP CABLE TO DIMENSIONS AS SHOWN</p>    | <p><b>STEP 2</b></p> <p>1. STRIP CABLE TO DIMENSIONS AS SHOWN</p>    |
| <p><b>STEP 3</b></p> <p>1. FIT CONTACT OVER CENTRE CONDUCTOR TO BUTT AGAINST DIELECTRIC.<br/>           2. CRIMP USING TOOL AS NOTES ON PAGE 1.</p>  <p>RECOMMENDED CENTRE CONTACT A/F HEX</p>    | <p><b>STEP 3</b></p> <p>1. SLIDE ITEM 10 PUSHER SLEEVE OVER DIELECTRIC BEFORE FITTING THE CONTACT.<br/>           2. FIT CONTACT OVER CENTRE CONDUCTOR TO BUTT AGAINST DIELECTRIC.<br/>           3. CRIMP USING TOOL AS NOTES ON PAGE 1.</p>  <p>RECOMMENDED CENTRE CONTACT A/F HEX</p>  |
| <p><b>STEP 4</b></p> <p>1. PRESS SUB-ASSEMBLY INTO BODY, UNTIL CONTACT IS FULLY LOCATED BY AN AUDIBLE CLICK.<br/>           2. ENSURE THAT KNURLED HOUSING INSERTS BETWEEN THE DIELECTRIC AND CABLE BRAID.</p>   | <p><b>STEP 4</b></p> <p>1. PRESS SUB-ASSEMBLY INTO BODY, UNTIL CONTACT IS FULLY LOCATED BY AN AUDIBLE CLICK.<br/>           2. ENSURE THAT KNURLED HOUSING INSERTS BETWEEN THE PUSHER SLEEVE AND CABLE BRAID.</p>    |
| <p><b>STEP 5</b></p> <p>1. SLIDE CRIMP FERRULE ALONG THE CABLE UNTIL IT BUTTS AGAINST THE HOUSING BODY.<br/>           2. CRIMP USING TOOL AS NOTED ON PAGE 1.<br/>           3. CRIMP DIMENSION X IS:-<br/>           RG59B (SEE PAGE 1 FOR FULL CABLE LIST) = 6.50<br/>           RG58C/U (SEE PAGE 1 FOR FULL CABLE LIST) = 5.60</p>  <p>RECOMMENDED CRIMP SLEEVE A/F HEX</p>  | <p><b>STEP 5</b></p> <p>1. SLIDE CRIMP FERRULE ALONG THE CABLE UNTIL IT BUTTS AGAINST THE BODY HOUSING.<br/>           2. CRIMP USING TOOL AS NOTED ON PAGE 1.<br/>           3. CRIMP DIMENSION AS SHOWN.</p>  <p>RECOMMENDED CRIMP SLEEVE A/F HEX</p>                                   |

THIS DRAWING IS A CONTROLLED DOCUMENT.

|   |   |
|---|---|
| DIMENSIONS: MM  | TOLERANCES UNLESS OTHERWISE SPECIFIED                           |
|  | 0 PLC ±<br>1 PLC ±<br>2 PLC ±<br>3 PLC ±<br>4 PLC ±<br>ANGLES ± |
| MATERIAL SEE TABLE  | FINISH SEE TABLE  |

|  |   |
|--|---|
| DWN RITA ZUO 19 Feb 09<br>CHK ANSON MA 19 Feb 09<br>APVD BOB ZHAO 19 Feb 09<br>PRODUCT SPEC 108-112000<br>APPLICATION SPEC SHEET 2<br>WEIGHT -<br>CUSTOMER DRAWING | Tyco Electronics Corporation<br>Kunshan, Jiangsu, PRC 215312<br>NAME BNC STRAIGHT PLUG HEX CRIMP 75 OHM<br>SIZE A2 CAGE CODE 00779 DRAWING NO C=1634502 RESTRICTED TO -<br>SCALE NTS SHEET 2 OF 2 REV D |
|--|---|

1634502

A