HD74LV221A

Dual Monostable Multivibrators

HITACHI

ADE-205-271 (Z)
1st Edition
April 1999

Description

The HD74LV221A features output pulse-duration control by three methods. In the first method, the A input is low and the B input goes high. In the second method, the B input is high and the \overline{A} input goes low. In the third method, the \overline{A} input is low, the B input is high, and the clear (\overline{CLR}) input goes high.

The basic pulse duration is programmed by selecting external resistance and capacitance values. The external timing capacitor must be connected between Cext and Rext/Cext (positive) and an external resistor connected between Rext/Cext and V_{CC} .

To obtain variable pulse durations, connect an external variable resistance between Rext/Cext and VCC. Pulse duration can be reduced by taking \overline{CLR} low.

Features

- $V_{CC} = 2.0\text{ V to }5.5\text{ V}$ operation
- All inputs $V_{IH} (\text{Max.}) = 5.5\text{ V}$ (@ $V_{CC} = 0\text{ V to }5.5\text{ V}$)
- All outputs $V_O (\text{Max.}) = 5.5\text{ V}$ (@ $V_{CC} = 0\text{ V}$)
- Output current $\pm 6\text{ mA}$ (@ $V_{CC} = 3.0\text{ V to }3.6\text{ V}$), $\pm 12\text{ mA}$ (@ $V_{CC} = 4.5\text{ V to }5.5\text{ V}$)

HD74LV221A

Function Table

Inputs			Outputs	
CLR	A	B	Q	Q
L	X	X	L	H
X	H	X	L	H
X	X	L	L	H
H	L	↑	⌋	⌋
H	↓	H	⌋	⌋
↑	L	H	⌋	⌋

Note: H: High level
 L: Low level
 X: Immaterial
 ↑: Low to high transition
 ↓: High to low transition
 ⌋: High level pulse
 ⌋: Low level pulse

Pin Arrangement

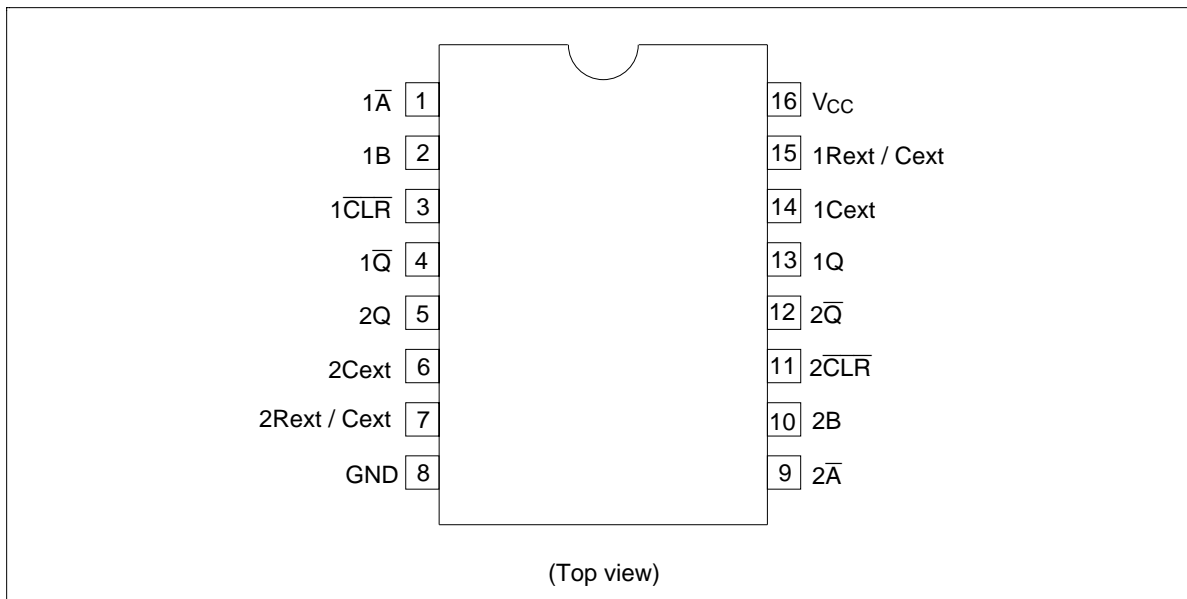

HITACHI

Absolute Maximum Ratings

Item	Symbol	Ratings	Unit	Conditions
Supply voltage range	V_{CC}	-0.5 to 7.0	V	
Input voltage range*1	V_I	-0.5 to 7.0	V	
Output voltage range*1, 2	V_O	-0.5 to $V_{CC} + 0.5$ -0.5 to 7.0	V	Output: H or L V_{CC} : OFF
Input clamp current	I_{IK}	-20	mA	$V_I < 0$
Output clamp current	I_{OK}	± 50	mA	$V_O < 0$ or $V_O > V_{CC}$
Continuous output current	I_O	± 25	mA	$V_O = 0$ to V_{CC}
Continuous current through V_{CC} or GND	I_{CC} or I_{GND}	± 50	mA	
Maximum power dissipation at $T_a = 25^\circ\text{C}$ (in still air)*3	P_T	785	mW	SOP
		500		TSSOP
Storage temperature	T_{stg}	-65 to 150	$^\circ\text{C}$	

Notes: The absolute maximum ratings are values which must not individually be exceeded, and furthermore, no two of which may be realized at the same time.

1. The input and output voltage ratings may be exceeded if the input and output clamp-current ratings are observed.
2. This value is limited to 5.5 V maximum.
3. The maximum package power dissipation was calculated using a junction temperature of 150°C .

HD74LV221A

Recommended Operating Conditions

Item	Symbol	Min	Typ	Max	Unit	Conditions
Supply voltage range	V_{CC}	2.0	—	5.5	V	
Input voltage range	V_I	0	—	5.5	V	
Output voltage range	V_O	0	—	V_{CC}	V	
Output current	I_{OH}	—	—	-50	μA	$V_{CC} = 2.0 V$
		—	—	-2	mA	$V_{CC} = 2.3 \text{ to } 2.7 V$
		—	—	-6		$V_{CC} = 3.0 \text{ to } 3.6 V$
		—	—	-12		$V_{CC} = 4.5 \text{ to } 5.5 V$
	I_{OL}	—	—	50	μA	$V_{CC} = 2.0 V$
		—	—	2	mA	$V_{CC} = 2.3 \text{ to } 2.7 V$
		—	—	6		$V_{CC} = 3.0 \text{ to } 3.6 V$
		—	—	12		$V_{CC} = 4.5 \text{ to } 5.5 V$
Input transition rise or fall rate	$\Delta t / \Delta v$	0	—	200	ns/V	$V_{CC} = 2.3 \text{ to } 2.7 V$
		0	—	100		$V_{CC} = 3.0 \text{ to } 3.6 V$
		0	—	20		$V_{CC} = 4.5 \text{ to } 5.5 V$
External timing resistance	Rext	5	—	—	k Ω	$V_{CC} = 2.0 V$
		1	—	—		$V_{CC} \geq 3.0 V$
External timing capacitance	Cext	—	unlimited	—	F	
Operating free-air temperature	Ta	-40		85	$^{\circ}C$	

Note: Unused or floating inputs must be held high or low.

Logic Diagram

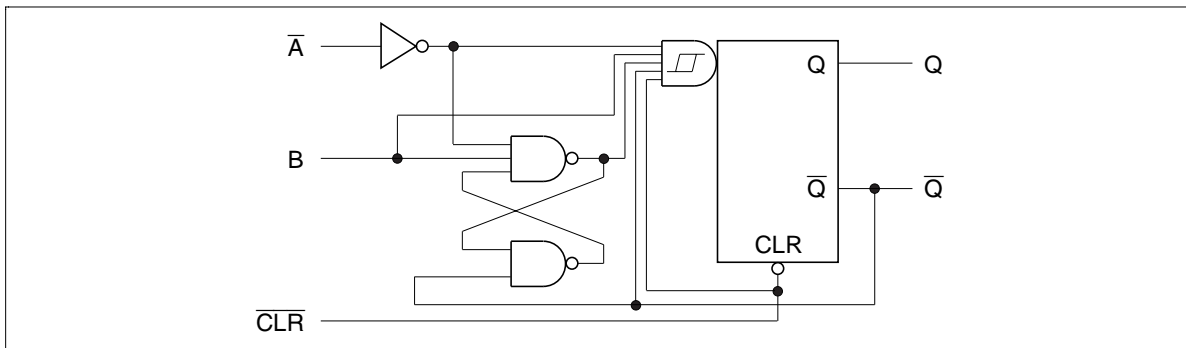

HITACHI

DC Electrical Characteristics

- $T_a = -40$ to 85°C

Item	Symbol	V_{CC} (V)*	Min	Typ	Max	Unit	Test Conditions	
Input voltage	V_{IH}	2.0	1.5	—	—	V		
		2.3 to 2.7	$V_{CC} \times 0.7$	—	—			
		3.0 to 3.6	$V_{CC} \times 0.7$	—	—			
		4.5 to 5.5	$V_{CC} \times 0.7$	—	—			
	V_{IL}	2.0	—	—	0.5			
		2.3 to 2.7	—	—	$V_{CC} \times 0.3$			
		3.0 to 3.6	—	—	$V_{CC} \times 0.3$			
		4.5 to 5.5	—	—	$V_{CC} \times 0.3$			
Output voltage	V_{OH}	Min to Max	$V_{CC} - 0.1$	—	—	V	$I_{OL} = -50 \mu\text{A}$	
		2.3	2.0	—	—		$I_{OL} = -2 \text{ mA}$	
		3.0	2.48	—	—		$I_{OL} = -6 \text{ mA}$	
		4.5	3.8	—	—		$I_{OL} = -12 \text{ mA}$	
	V_{OL}	Min to Max	—	—	0.1		V	$I_{OL} = 50 \mu\text{A}$
		2.3	—	—	0.4			$I_{OL} = 2 \text{ mA}$
		3.0	—	—	0.44			$I_{OL} = 6 \text{ mA}$
		4.5	—	—	0.55			$I_{OL} = 12 \text{ mA}$
Input current	I_{IN}	0 to 5.5	—	—	± 1	μA		$V_{IN} = 5.5 \text{ V}$ or GND
Quiescent supply current	I_{CC}	5.5	—	—	20	μA		$V_{IN} = V_{CC}$ or GND, $I_O = 0$
Active state supply current (per circuit)	ΔI_{CC}	2.3	—	—	220	μA		$V_{IN} = V_{CC}$ or GND $R_{ext}/C_{ext} = 0.5 \text{ V}$
		3.0	—	—	280			
		4.5	—	—	650			
		5.5	—	—	975			
Output leakage current	I_{OFF}	0	—	—	5	μA	$V_O = 5.5 \text{ V}$	
Input capacitance	C_{IN}	3.3	—	4.0	—	pF	$V_I = V_{CC}$ or GND	

Note: For conditions shown as Min or Max, use the appropriate values under recommended operating conditions.

HD74LV221A

Switching Characteristics

- $V_{CC} = 2.5 \pm 0.2 V$

Item	Symbol	Ta = 25°C			Ta = -40 to 85°C		Unit	Test Conditions	FROM (Input)	TO (Output)
		Min	Typ	Max	Min	Max				
Propagation delay time	t_{PLH}	—	13.3	31.4	1.0	37.0	ns	$C_L = 15 pF$	A or B	Q or \bar{Q}
	t_{PHL}	—	15.5	36.0	1.0	42.0		$C_L = 50 pF$		
		—	10.9	25.0	1.0	29.5		$C_L = 15 pF$	\bar{CLR}	Q or \bar{Q}
		—	12.5	32.8	1.0	34.5		$C_L = 50 pF$		
		—	13.5	33.4	1.0	39.0		$C_L = 15 pF$	\bar{CLR}	Q or \bar{Q}
		—	15.9	38.0	1.0	44.0		$C_L = 50 pF$	(Trigger)	
Pulse width	t_w	6.0	—	—	6.5	—	ns	\bar{A}, B or \bar{CLR}		
Output pulse width	t_{wQ}	—	170	260	—	320	ns	$C_L = 50 pF,$ $C_{ext} = 28 pF, R_{ext} = 2 k\Omega$		
		90	100	110	90	110	μs	$C_L = 50 pF,$ $C_{ext} = 0.01 \mu F, R_{ext} = 10 k\Omega$		
		0.9	1.0	1.1	0.9	1.1	ms	$C_L = 50 pF,$ $C_{ext} = 0.1 \mu F, R_{ext} = 10 k\Omega$		
	Δt_{wQ}	—	± 1	—	—	—	%	$C_L = 50 pF$		

Switching Characteristics (cont)

- $V_{CC} = 3.3 \pm 0.3 V$

Item	Symbol	Ta = 25°C			Ta = -40 to 85°C		Unit	Test Conditions	FROM (Input)	TO (Output)
		Min	Typ	Max	Min	Max				
Propagation delay time	t_{PLH}	—	9.9	20.6	1.0	24.0	ns	$C_L = 15 pF$	A or B	Q or \bar{Q}
	t_{PHL}	—	11.6	24.1	1.0	27.5		$C_L = 50 pF$		
		—	8.3	15.8	1.0	18.5		$C_L = 15 pF$	\bar{CLR}	Q or \bar{Q}
		—	9.7	19.3	1.0	22.0		$C_L = 50 pF$		
		—	9.9	22.4	1.0	26.0		$C_L = 15 pF$	\bar{CLR}	Q or \bar{Q}
		—	11.6	25.9	1.0	29.5		$C_L = 50 pF$	(Trigger)	
Pulse width	t_w	5.0	—	—	5.0	—	ns	\bar{A}, B or \bar{CLR}		
Output pulse width	t_{wQ}	—	150	240	—	300	ns	$C_L = 50 pF,$ $C_{ext} = 28 pF, R_{ext} = 2 k\Omega$		
		90	100	110	90	110	μs	$C_L = 50 pF,$ $C_{ext} = 0.01 \mu F, R_{ext} = 10 k\Omega$		
		0.9	1.0	1.1	0.9	1.1	ms	$C_L = 50 pF,$ $C_{ext} = 0.1 \mu F, R_{ext} = 10 k\Omega$		
	Δt_{wQ}	—	± 1	—	—	—	%	$C_L = 50 pF$		

HD74LV221A

Switching Characteristics (cont)

- $V_{CC} = 5.0 \pm 0.5 \text{ V}$

Item	Symbol	Ta = 25°C			Ta = -40 to 85°C		Unit	Test Conditions	FROM (Input)	TO (Output)
		Min	Typ	Max	Min	Max				
Propagation delay time	t_{PLH}	—	7.3	12.0	1.0	14.0	ns	$C_L = 15 \text{ pF}$	A or B	Q or \bar{Q}
	t_{PHL}	—	8.7	14.0	1.0	16.0		$C_L = 50 \text{ pF}$		
		—	6.2	9.4	1.0	11.0		$C_L = 15 \text{ pF}$	\bar{CLR}	Q or \bar{Q}
		—	7.4	11.4	1.0	13.0		$C_L = 50 \text{ pF}$		
		—	7.3	12.9	1.0	15.0		$C_L = 15 \text{ pF}$	\bar{CLR}	Q or \bar{Q}
		—	8.6	14.9	1.0	17.0		$C_L = 50 \text{ pF}$	(Trigger)	
Pulse width	t_w	5.0	—	—	5.0	—	ns	\bar{A}, B or \bar{CLR}		
Output pulse width	t_{wQ}	—	140	200	—	240	ns	$C_L = 50 \text{ pF}$, $C_{ext} = 28 \text{ pF}$, $R_{ext} = 2 \text{ k}\Omega$		
		90	100	110	90	110	μs	$C_L = 50 \text{ pF}$, $C_{ext} = 0.01 \mu\text{F}$, $R_{ext} = 10 \text{ k}\Omega$		
		0.9	1.0	1.1	0.9	1.1	ms	$C_L = 50 \text{ pF}$, $C_{ext} = 0.1 \mu\text{F}$, $R_{ext} = 10 \text{ k}\Omega$		
	Δt_{wQ}	—	± 1	—	—	—	%	$C_L = 50 \text{ pF}$		

Operating Characteristics

- $C_L = 50 \text{ pF}$

Item	Symbol	V_{CC} (V)	$T_a = 25^\circ\text{C}$			Unit	Test Conditions
			Min	Typ	Max		
Power dissipation capacitance	C_{PD}	3.3	—	74.0	—	pF	$f = 10 \text{ MHz}$
		5.0	—	86.0	—		

Test Circuit

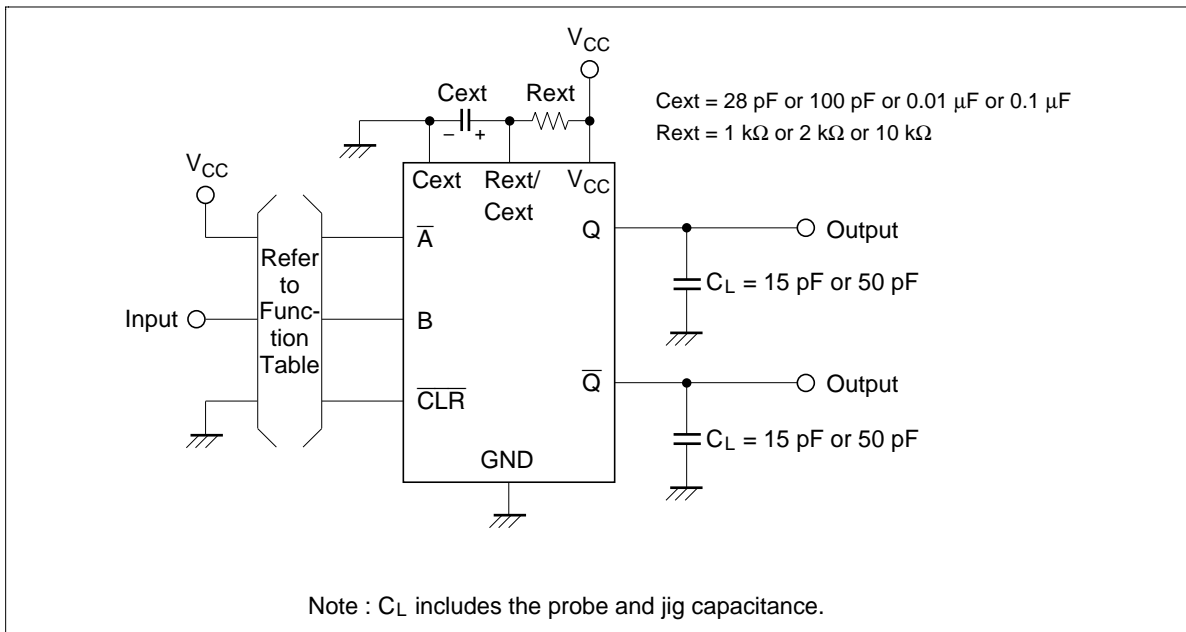

HD74LV221A

Timing diagram

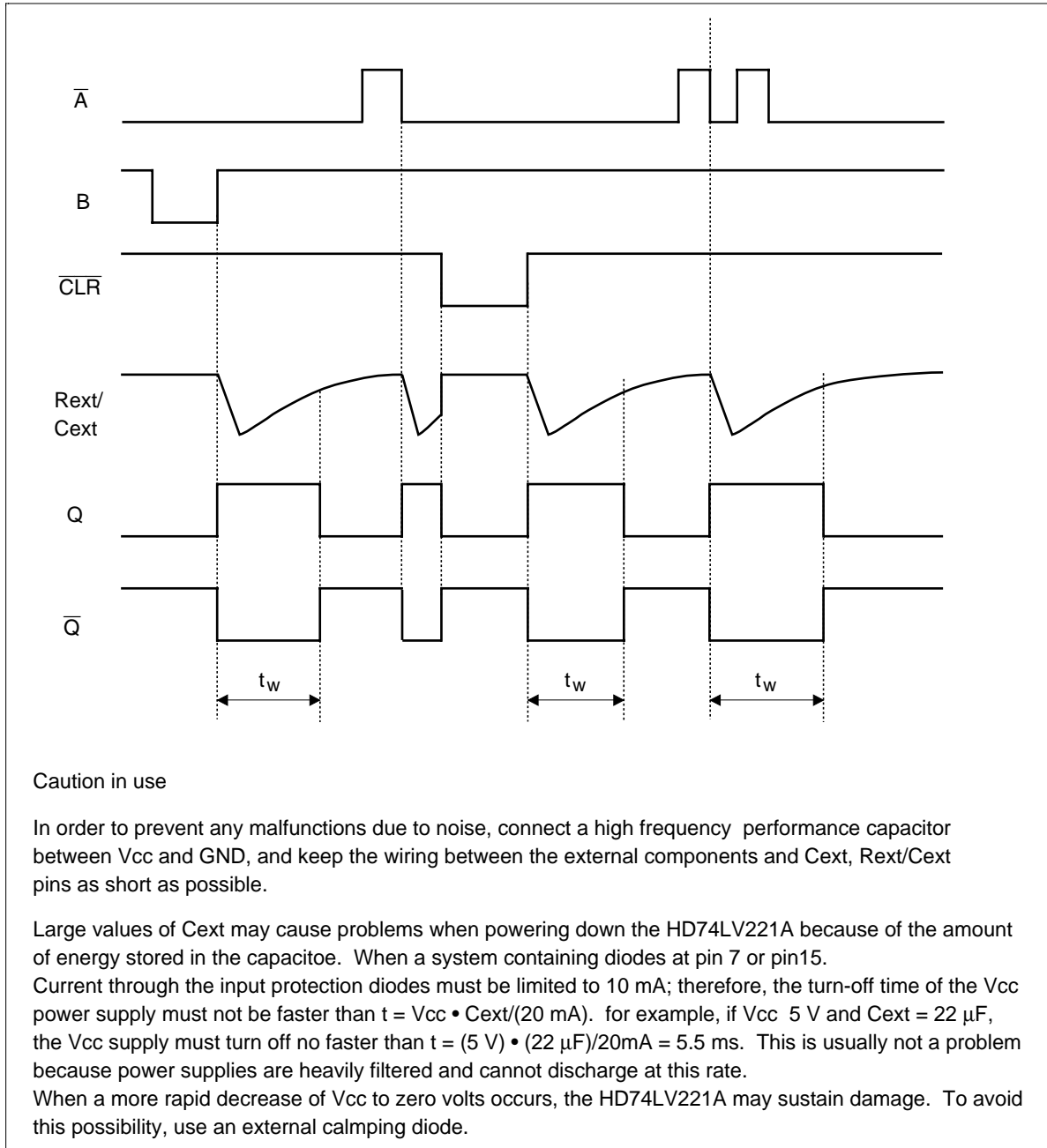

HITACHI

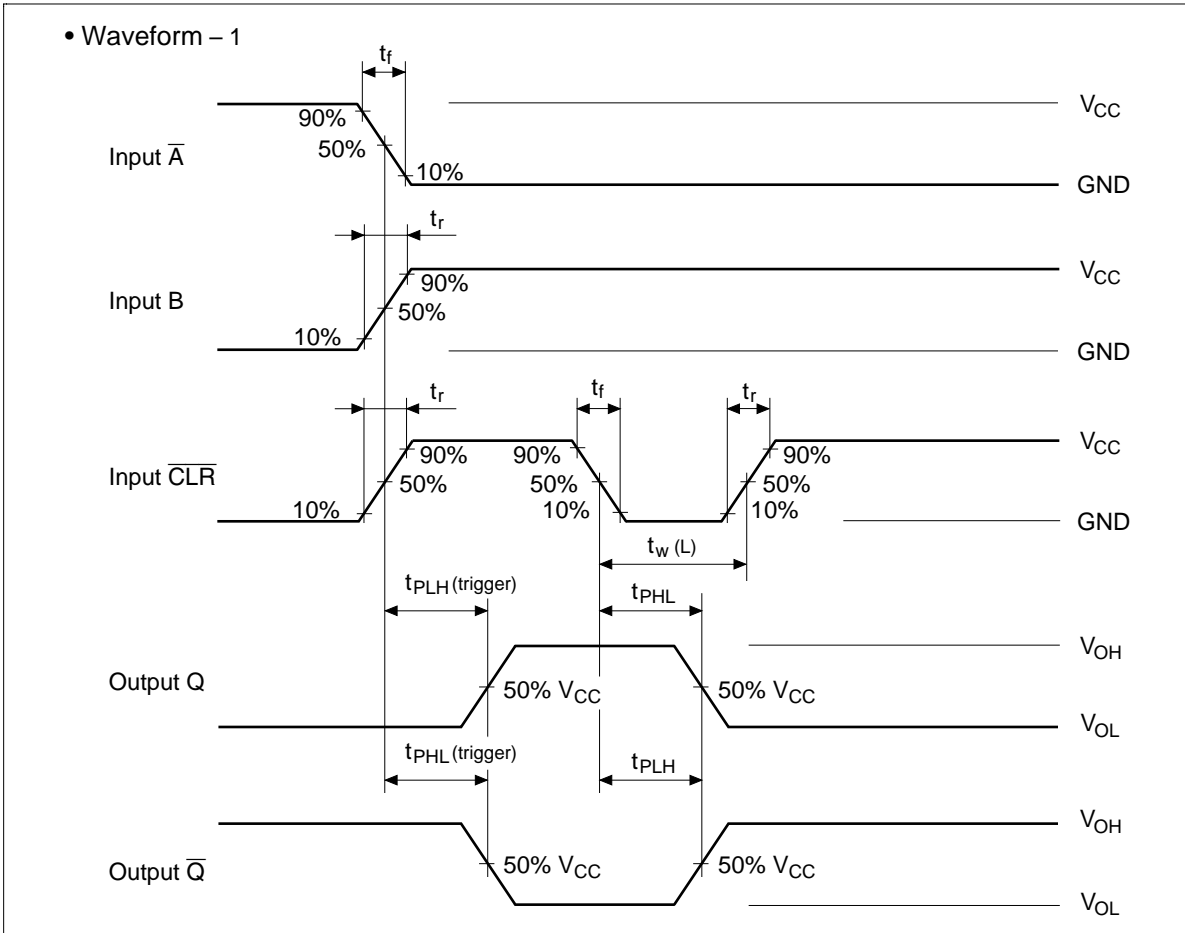

HD74LV221A

• Waveform – 2

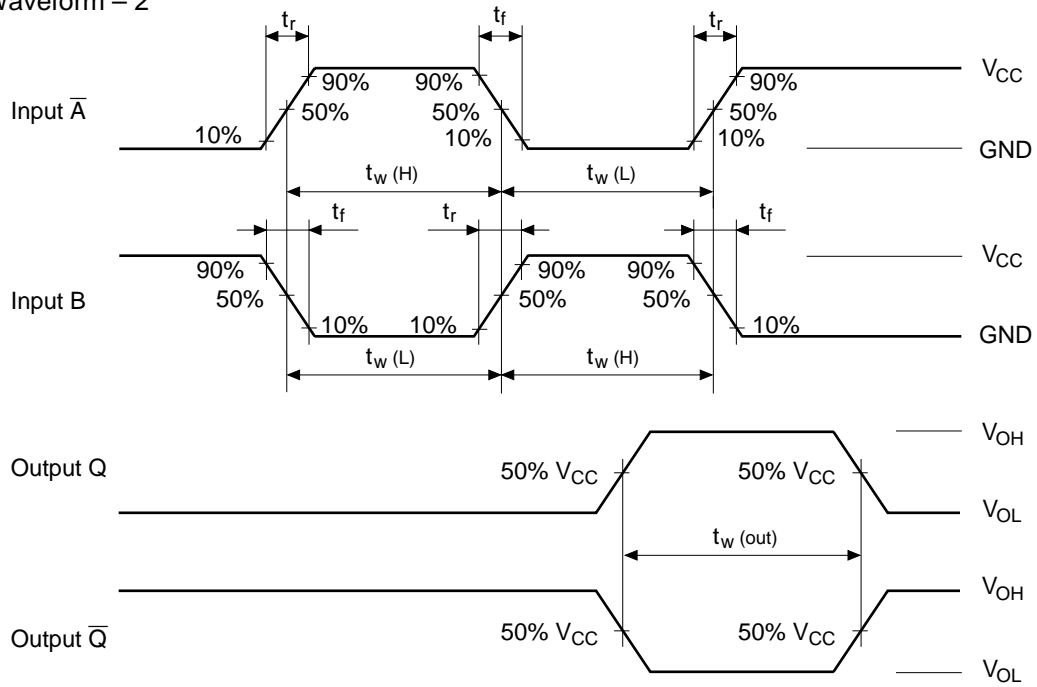

- Note: 1. Input waveform: $PRR \leq 1 \text{ MHz}$, $Z_o = 50 \Omega$, $t_r \leq 3 \text{ ns}$, $t_f \leq 3 \text{ ns}$
 2. The output are measured one at a time with one transition per measurement.

Application Data

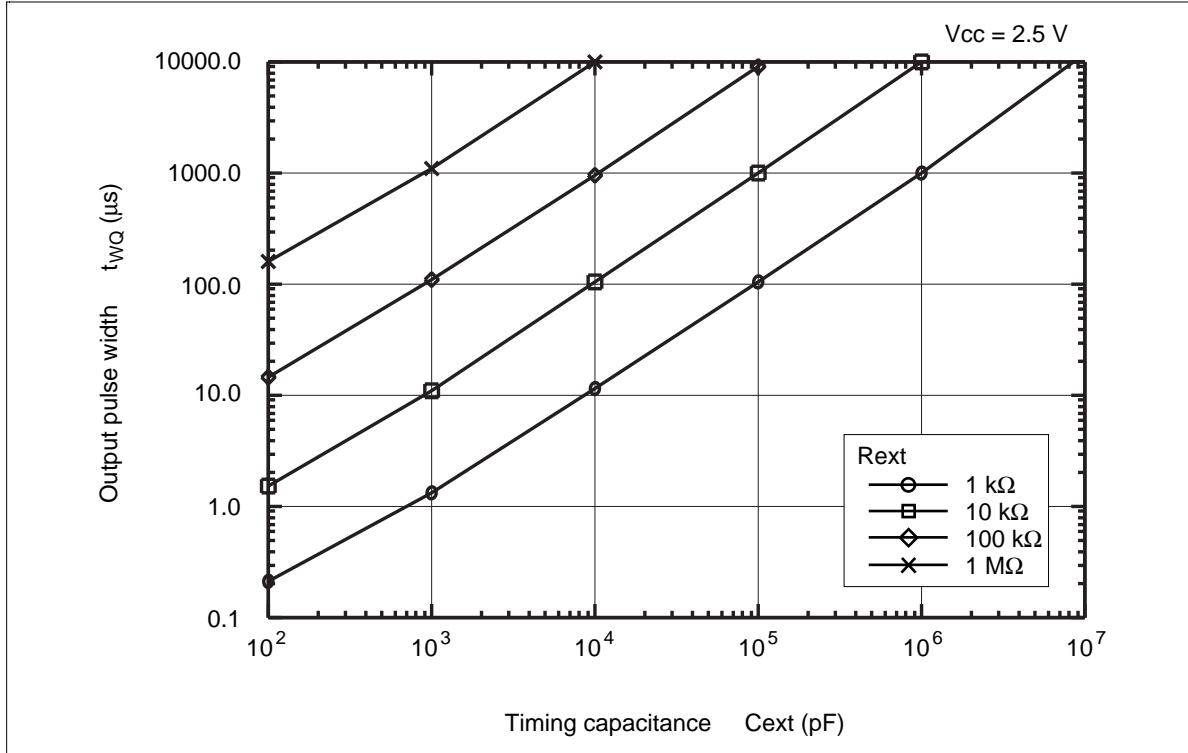

HD74LV221A

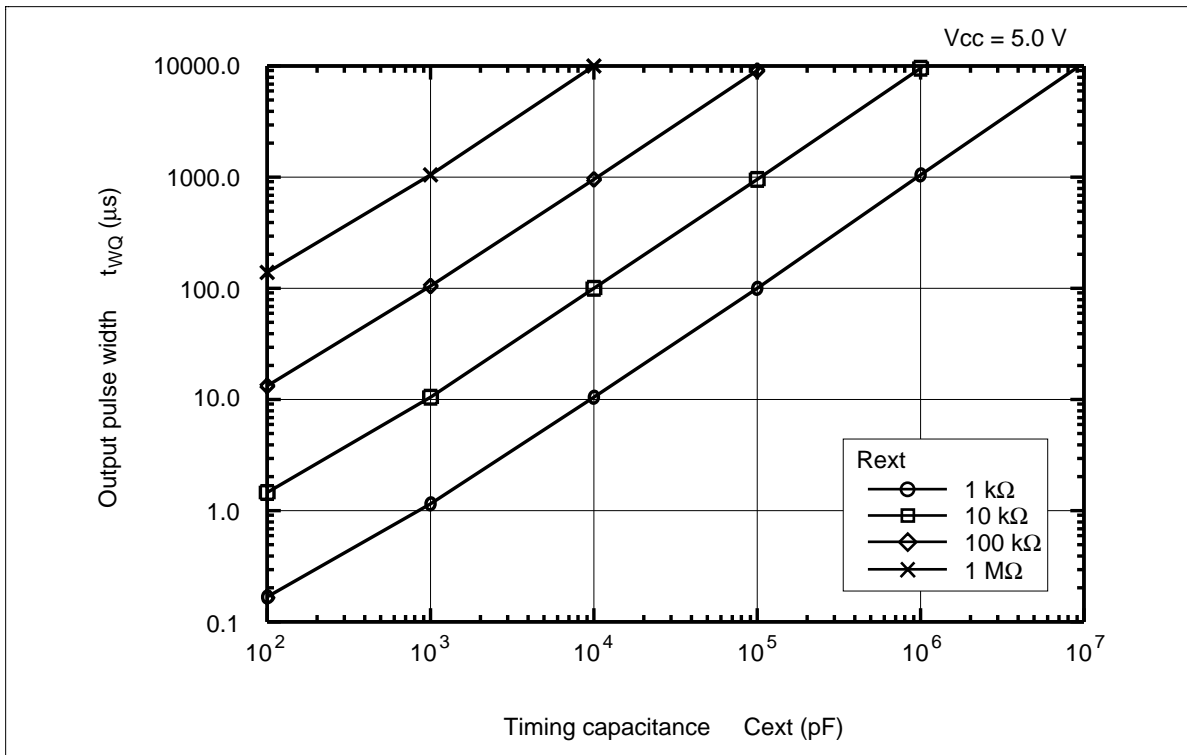
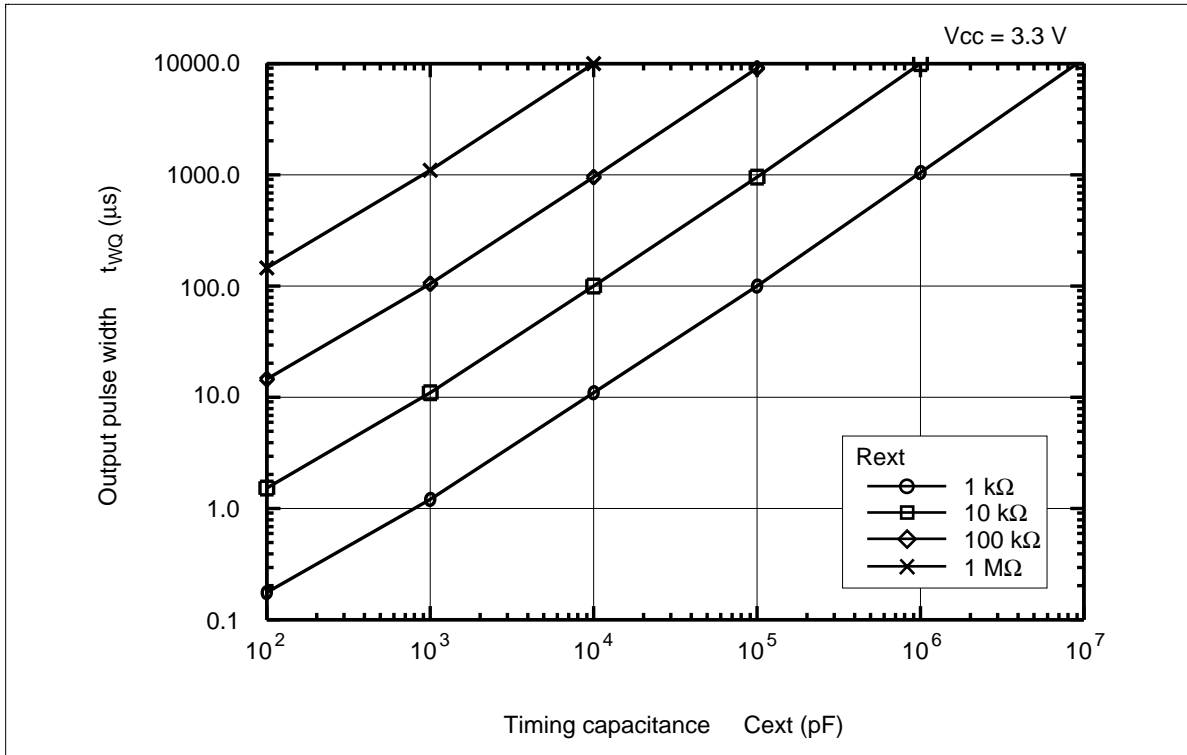

HITACHI

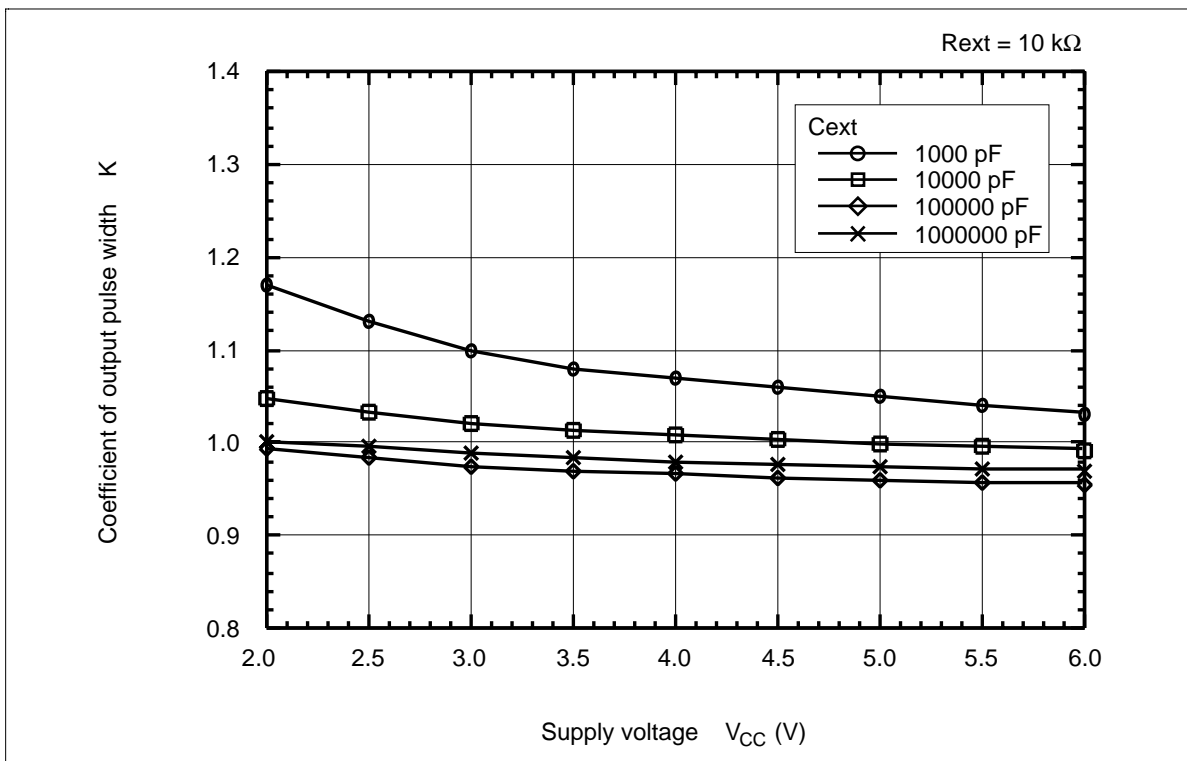
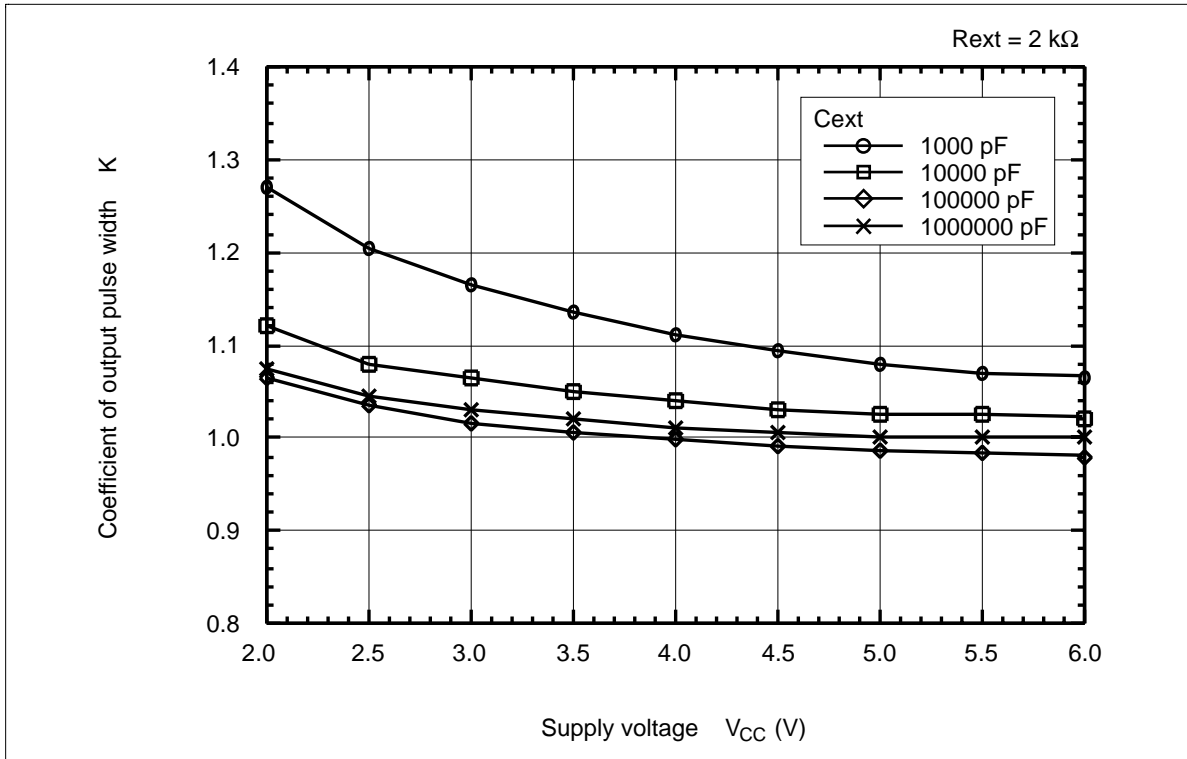

HD74LV221A

Package Dimensions

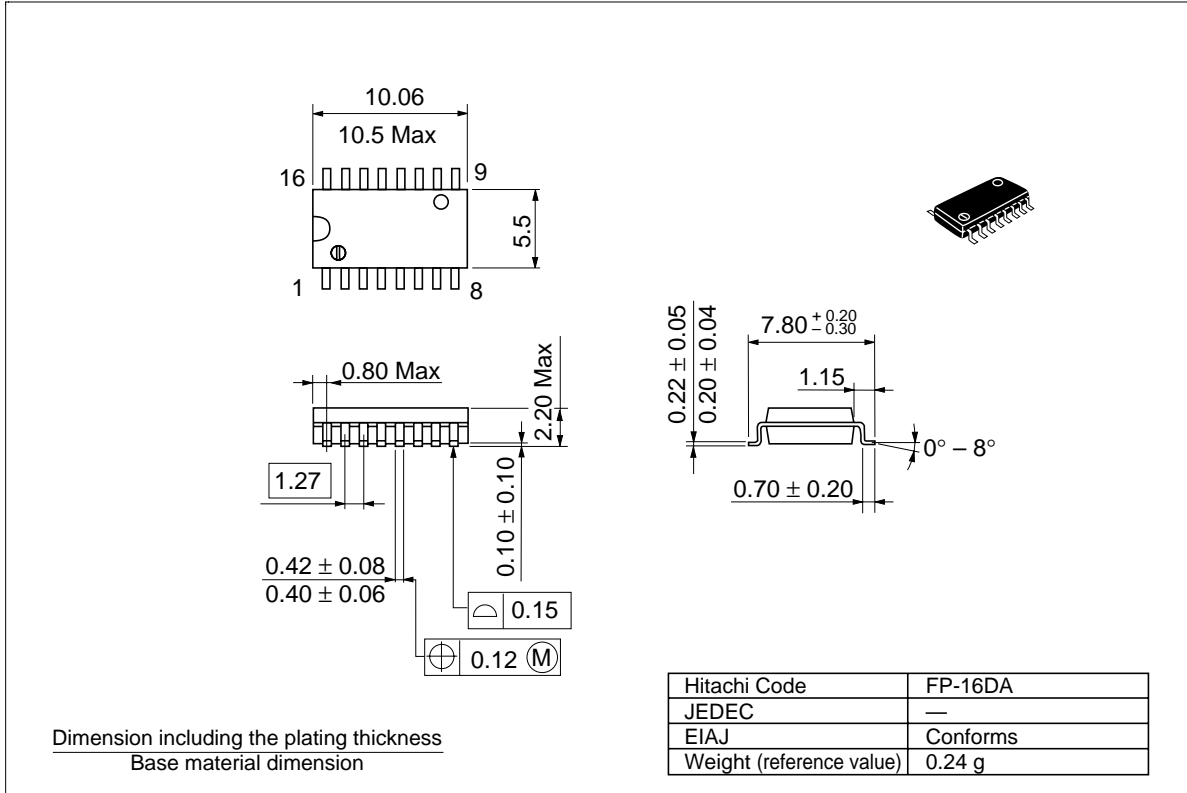

HD74LV221A

Unit: mm

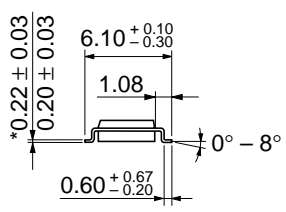
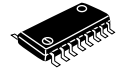
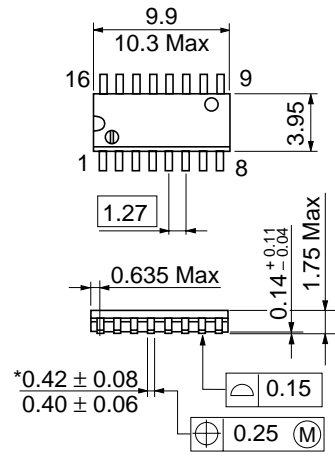

*Dimension including the plating thickness
Base material dimension

Hitachi Code	FP-16DN
JEDEC	Conforms
EIAJ	Conforms
Weight (reference value)	0.15 g

HD74LV221A

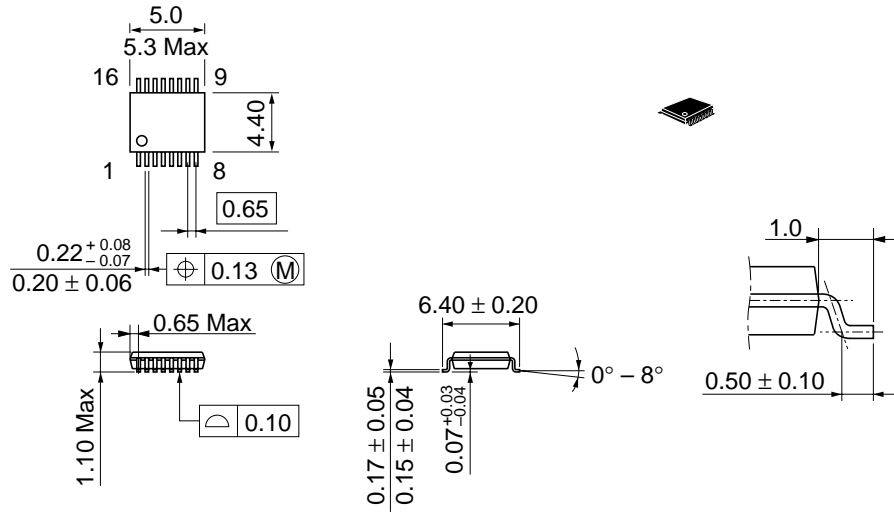

Dimension including the plating thickness
Base material dimension

Hitachi Code	TTP-16DA
JEDEC	—
EIAJ	—
Weight (reference value)	0.05 g

Cautions

1. Hitachi neither warrants nor grants licenses of any rights of Hitachi's or any third party's patent, copyright, trademark, or other intellectual property rights for information contained in this document. Hitachi bears no responsibility for problems that may arise with third party's rights, including intellectual property rights, in connection with use of the information contained in this document.
2. Products and product specifications may be subject to change without notice. Confirm that you have received the latest product standards or specifications before final design, purchase or use.
3. Hitachi makes every attempt to ensure that its products are of high quality and reliability. However, contact Hitachi's sales office before using the product in an application that demands especially high quality and reliability or where its failure or malfunction may directly threaten human life or cause risk of bodily injury, such as in aerospace, aeronautics, nuclear power, combustion control, transportation, traffic, safety equipment or medical equipment for life support.
4. Design your application so that the product is used within the ranges guaranteed by Hitachi particularly for maximum rating, operating supply voltage range, heat radiation characteristics, installation conditions and other characteristics. Hitachi bears no responsibility for failure or damage when used beyond the guaranteed ranges. Even within the guaranteed ranges, consider normally foreseeable failure rates or failure modes in semiconductor devices and employ systemic measures such as fail-safe devices, so that the equipment incorporating the Hitachi product does not cause bodily injury, fire or other consequential damage due to operation of the Hitachi product.
5. This product is not designed to be radiation resistant.
6. No one is permitted to reproduce or duplicate, in any form, the whole or part of this document without written approval from Hitachi.
7. Contact Hitachi's sales office for any questions regarding this document or Hitachi semiconductor products.

HITACHI**Hitachi, Ltd.**

Semiconductor & Integrated Circuits.
Nippon Bldg., 2-6-2, Ohte-machi, Chiyoda-ku, Tokyo 100-0004, Japan
Tel: Tokyo (03) 3270-2111 Fax: (03) 3270-5109

URL North America : <http://semiconductor.hitachi.com/>
 Europe : <http://www.hitachi-eu.com/hel/ecg>
 Asia (Singapore) : <http://www.has.hitachi.com.sg/grp3/sicd/index.htm>
 Asia (Taiwan) : http://www.hitachi.com.tw/E/Product/SICD_Frame.htm
 Asia (HongKong) : <http://www.hitachi.com.hk/eng/bo/grp3/index.htm>
 Japan : <http://www.hitachi.co.jp/Sicd/indx.htm>

For further information write to:

Hitachi Semiconductor
(America) Inc.
179 East Tasman Drive,
San Jose, CA 95134
Tel: <1> (408) 433-1990
Fax: <1> (408) 433-0223

Hitachi Europe GmbH
Electronic components Group
Dornacher Straße 3
D-85622 Feldkirchen, Munich
Germany
Tel: <49> (89) 9 9180-0
Fax: <49> (89) 9 29 30 00

Hitachi Europe Ltd.
Electronic Components Group.
Whitebrook Park
Lower Cookham Road
Maidenhead
Berkshire SL6 8YA, United Kingdom
Tel: <44> (1628) 585000
Fax: <44> (1628) 778322

Hitachi Asia Pte. Ltd.
16 Collyer Quay #20-00
Hitachi Tower
Singapore 049318
Tel: 535-2100
Fax: 535-1533

Hitachi Asia Ltd.
Taipei Branch Office
3F, Hung Kuo Building, No.167,
Tun-Hwa North Road, Taipei (105)
Tel: <886> (2) 2718-3666
Fax: <886> (2) 2718-8180

Hitachi Asia (Hong Kong) Ltd.
Group III (Electronic Components)
7/F., North Tower, World Finance Centre,
Harbour City, Canton Road, Tsim Sha Tsui,
Kowloon, Hong Kong
Tel: <852> (2) 735 9218
Fax: <852> (2) 730 0281
Telex: 40815 HITEC HX

Copyright © Hitachi, Ltd., 1998. All rights reserved. Printed in Japan.

HITACHI