



SANYO Semiconductors

DATA SHEET

LV8044LP — Bi-CMOS IC LV8044LQ — For Digital Still Camera 6-channel Motor Driver IC

Overview

The LV8044LP and LV8044LQ is a 6-channel motor driver IC for digital still camera.

Functions

- Two microstep drive H-bridge driver channels.
- Two microstep drive/PWM saturated drive switchable H-bridge driver channels.
- Two constant-current drive H-bridge driver channels.
- Drive mode switchable between 2-phase, 1-2 phase full torque, 1-2 phase, and 4W1-2 phase (channels 1, 2, 3, and 4).
- Microstep drive step advance controlled by a single step signal input (channels 1, 2, 3, and 4).
- Ability to set the hold current to one of four levels (channels 1, 2, 3, and 4).
- Ability to set the constant-current reference voltage to one of 16 levels from the serial data (channels 5 and 6).
- Eight-bit 3-wire serial control.
- Three on-chip photosensor driver circuits.

Specifications

Maximum Ratings at Ta = 25°C

Parameter	Symbol	Conditions	Ratings	Unit
Power supply voltage 1	V _M max		6.0	V
Power supply voltage 2	V _{CC} max		6.0	V
Output peak current	I _O peak	Each CH tw ≤ 10ms, duty 20%	600	mA
Output continuous current	I _O max	Each CH	400	mA
Allowable power dissipation 2	Pd max	LV8044LP With substrate *	1.4	W
		LV8044LQ With substrate *	1.35	W
Operating temperature	Topg		-20 to +85	°C
Storage temperature	Tstg		-55 to +150	°C

*: With 40mm × 50mm × 0.8mm glass epoxy substrate (four-layer substrate).

■ Any and all SANYO Semiconductor Co.,Ltd. products described or contained herein are, with regard to "standard application", intended for the use as general electronics equipment (home appliances, AV equipment, communication device, office equipment, industrial equipment etc.). The products mentioned herein shall not be intended for use for any "special application" (medical equipment whose purpose is to sustain life, aerospace instrument, nuclear control device, burning appliances, transportation machine, traffic signal system, safety equipment etc.) that shall require extremely high level of reliability and can directly threaten human lives in case of failure or malfunction of the product or may cause harm to human bodies, nor shall they grant any guarantee thereof. If you should intend to use our products for applications outside the standard applications of our customer who is considering such use and/or outside the scope of our intended standard applications, please consult with us prior to the intended use. If there is no consultation or inquiry before the intended use, our customer shall be solely responsible for the use.

■ Specifications of any and all SANYO Semiconductor Co.,Ltd. products described or contained herein stipulate the performance, characteristics, and functions of the described products in the independent state, and are not guarantees of the performance, characteristics, and functions of the described products as mounted in the customer's products or equipment. To verify symptoms and states that cannot be evaluated in an independent device, the customer should always evaluate and test devices mounted in the customer's products or equipment.

SANYO Semiconductor Co., Ltd.

TOKYO OFFICE Tokyo Bldg., 1-10, 1 Chome, Ueno, Taito-ku, TOKYO, 110-8534 JAPAN

LV8044LP, LV8044LQ

Recommended Operating Conditions at Ta = 25°C

Parameter	Symbol	Conditions	Ratings	Unit
Power supply voltage range 1	V _M		2.7 to 5.5	V
Power supply voltage range 2	V _{CC}		2.7 to 5.5	V
Logic input voltage range	V _{IN}		0 to V _{CC} +0.3	V
STEP frequency	F _{STEP}	STEP1, STEP2	to 64	KHz
PWM frequency	F _{PWM}	STEP3, STEP4	to 100	KHz

Electrical Characteristics at Ta = 25°C, V_M = 5V, V_{CC} = 3.3V

Parameter	Symbol	Conditions	Ratings			Unit	
			min	typ	max		
Standby supply current	I _{STN}	ST = "L"			1.0	μA	
Motor supply current	I _M	ST = "H", PWM3 = PWM4 = "H", IN51 = IN61 = "H", no load		50	100	μA	
Logic supply current	I _{CC}	ST = "H", PWM3 = PWM4 = "H", IN51 = IN61 = "H", no load	2	3	4	mA	
V _{CC} low-voltage cut voltage	V _{th} V _{CC}		2.1	2.35	2.6	V	
Low-voltage hysteresis voltage	V _{th} HIS		100	150	200	mV	
Thermal shutdown temperature	TSD	Design guarantee	150	180	200	°C	
Thermal hysteresis width	ΔTSD	Design guarantee		40		°C	
Microstep Driver (channels 1, 2, 3, and 4)							
Output on resistance	R _{on}	I _O = 400mA, Upper ON resistance		0.7	0.8	Ω	
	R _{od}	I _O = 400mA, Lower ON resistance		0.5	0.6	Ω	
Output leak current	I _{Oleak1}				1.0	μA	
Diode forward voltage 1	V _{D1}	I _D = -400mA		0.9	1.2	V	
Logic pin input current	I _{inL}	V _{IN} = 0V (ST, STEP1, STEP2)			1.0	μA	
	I _{inH}	V _{IN} = 3.3V (ST, STEP1, STEP2)	20	33	50	μA	
Logic input "H" level voltage	V _{inH}	ST, STEP1, STEP2	2.5			V	
Logic input "L" level voltage	V _{inL}	ST, STEP1, STEP2			1.0	V	
Current selection reference voltage level	4W1-2 phase	V _{step16}	Step 16 (Initial level: the channel 1 comparator level)	0.185	0.200	0.215	V
		V _{step15}	Step 15 (Initial+1)	0.185	0.200	0.215	V
		V _{step14}	Step 14 (Initial+2)	0.185	0.200	0.215	V
		V _{step13}	Step 13 (Initial+3)	0.176	0.193	0.206	V
		V _{step12}	Step 12 (Initial+4)	0.170	0.186	0.200	V
		V _{step11}	Step 11 (Initial+5)	0.162	0.178	0.192	V
		V _{step10}	Step 10 (Initial+6)	0.154	0.171	0.184	V
		V _{step9}	Step 9 (Initial+7)	0.146	0.163	0.176	V
		V _{step8}	Step 8 (Initial+8)	0.129	0.148	0.159	V
		V _{step7}	Step 7 (Initial+9)	0.113	0.131	0.143	V
		V _{step6}	Step 6 (Initial+10)	0.097	0.115	0.127	V
		V _{step5}	Step 5 (Initial+11)	0.079	0.097	0.109	V
		V _{step4}	Step 4 (Initial+12)	0.062	0.079	0.092	V
		V _{step3}	Step 3 (Initial+13)	0.044	0.06	0.074	V
		V _{step2}	Step 2 (Initial+14)	0.024	0.04	0.054	V
	V _{step1}	Step 1 (Initial+15)	0.006	0.02	0.036	V	
	1-2 phase	V _{step16}	Step 16 (Initial level: the channel 1 comparator level)	0.185	0.200	0.215	V
		V _{step8}	Step 8 (Initial+1)	0.129	0.148	0.159	V
	1-2 phase (Full torque)	V _{step16}	Step 16 (Initial level: the channel 1 comparator level)	0.185	0.200	0.215	V
		V _{step8}	Step 8 (Initial+1)	0.185	0.200	0.215	V
2 phase	V _{step8}	Step 8	0.185	0.200	0.215	V	

Continued on next page.

LV8044LP, LV8044LQ

Continued from preceding page.

Parameter	Symbol	Conditions	Ratings			Unit
			min	typ	max	
Chopping frequency	fchop1		104	130	156	KHz
	fchop2		52	65	78	KHz
	fchop3		160	200	240	KHz
	fchop4		80	100	120	KHz
Current setting reference voltage	VSEN00	(D5, D6) = (0, 0)	0.185	0.200	0.215	V
	VSEN01	(D5, D6) = (0, 1)	0.119	0.134	0.149	V
	VSEN10	(D5, D6) = (1, 0)	0.085	0.100	0.115	V
	VSEN11	(D5, D6) = (1, 1)	0.051	0.066	0.081	V
Constant-Current Drive (channels 5 and 6)						
Output on resistance	R _{on}	I _O = 400mA, Upper ON resistance		0.7	0.8	Ω
	R _{on}	I _O = 400mA, Lower ON resistance		0.5	0.6	Ω
Output leak current	I _O leak				1.0	μA
Diode forward voltage 1	V _D 1	I _D = -400mA		0.9	1.2	V
Logic pin input current	I _{in} L	V _{IN} = 0V, (IN51, IN52, IN61, IN62)			1.0	μA
	I _{in} H	V _{IN} = 3.3V, (IN51, IN52, IN61, IN62)	20	33	50	μA
Logic input "H" level voltage	V _{in} h	IN51, IN52, IN61, IN62	2.5			V
Logic input "L" level voltage	V _{in} l	IN51, IN52, IN61, IN62			1.0	V
Output constant current	I _{OUT}	R _{load} = 3Ω, R _F = 0.5Ω, Internal standard = 0.2V	380	400	420	mA
Current setting reference voltage	Vref0	(D4, D5, D6, D7) = (0, 0, 0, 0)	0.285	0.30	0.315	V
	Vref1	(D4, D5, D6, D7) = (1, 0, 0, 0)	0.19	0.20	0.21	V
	Vref2	(D4, D5, D6, D7) = (0, 1, 0, 0)	0.18	0.190	0.2	V
	Vref3	(D4, D5, D6, D7) = (1, 1, 0, 0)	0.171	0.180	0.189	V
	Vref4	(D4, D5, D6, D7) = (0, 0, 1, 0)	0.161	0.170	0.179	V
	Vref5	(D4, D5, D6, D7) = (1, 0, 1, 0)	0.156	0.165	0.173	V
	Vref6	(D4, D5, D6, D7) = (0, 1, 1, 0)	0.152	0.160	0.168	V
	Vref7	(D4, D5, D6, D7) = (1, 1, 1, 0)	0.147	0.155	0.163	V
	Vref8	(D4, D5, D6, D7) = (0, 0, 0, 1)	0.143	0.150	0.158	V
	Vref9	(D4, D5, D6, D7) = (1, 0, 0, 1)	0.137	0.145	0.152	V
	VrefA	(D4, D5, D6, D7) = (0, 1, 0, 1)	0.133	0.140	0.147	V
	VrefB	(D4, D5, D6, D7) = (1, 1, 0, 1)	0.128	0.135	0.142	V
	VrefC	(D4, D5, D6, D7) = (0, 0, 1, 1)	0.123	0.130	0.137	V
	VrefD	(D4, D5, D6, D7) = (1, 0, 1, 1)	0.114	0.120	0.126	V
	VrefE	(D4, D5, D6, D7) = (0, 1, 1, 1)	0.104	0.110	0.116	V
	VrefF	(D4, D5, D6, D7) = (1, 1, 1, 1)	0.095	0.100	0.105	V
Photo-sensor Drive Circuit						
Output saturation voltage	V _{sat}	I _O = -20mA		0.09	0.12	V
Serial Data Transfer Pin						
Logic pin input current	I _{in} L	V _{IN} = 0V (SCLK, SDATA, STB)			1.0	μA
	I _{in} H	V _{IN} = 3.3V (SCLK, SDATA, STB)	20	33	50	μA
Logic input "H" level voltage	V _{in} h	SCLK, SDATA, STB	2.5			V
Logic input "L" level voltage	V _{in} l	SCLK, SDATA, STB			1.0	V
Minimum SCLK "H" pulse width	T _{ckh}		0.125			μs
Minimum SCLK "L" pulse width	T _{ckl}		0.125			μs
Minimum setup time (STB → SCLK rising edge)	T _{sup1}		0.125			μs
Minimum setup time (SCLK rising edge → STB)	T _{sup2}		0.125			μs
Minimum STB pulse width	T _{stbw}		0.125			μs
Data setup time	T _{ds}		0.125			μs
Data hold time	T _{dh}		0.125			μs
Maximum SCLK frequency	F _{clk}				4	MHz

LV8044LP, LV8044LQ

Serial Input Switching Characteristics Timing Chart

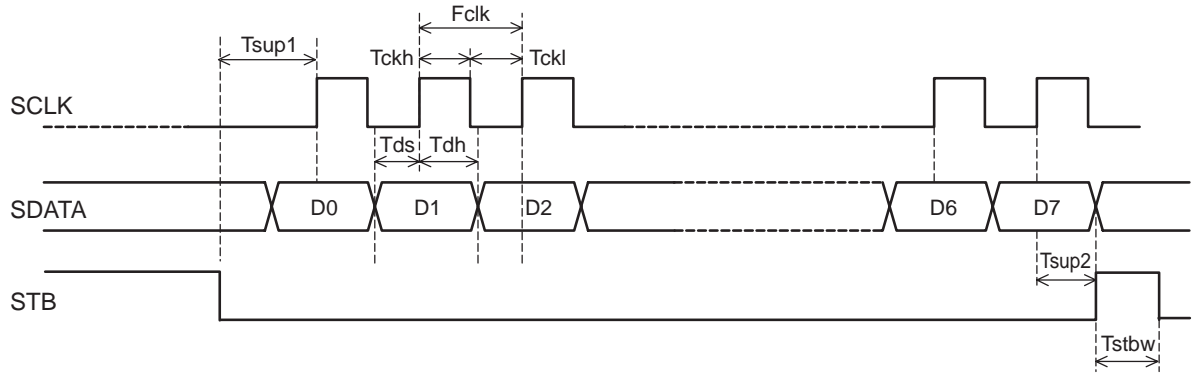

Package Dimensions

unit : mm (typ)

3302A

[LV8044LP] 3351

[LV8044LQ]

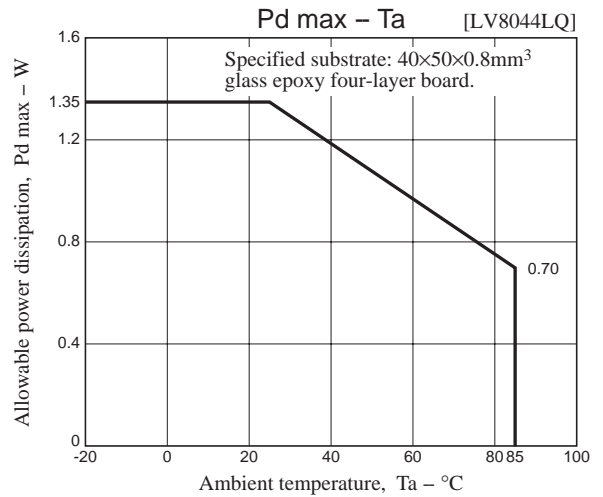
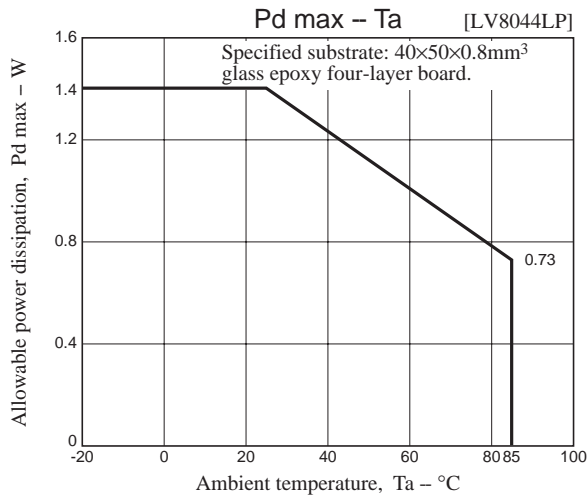
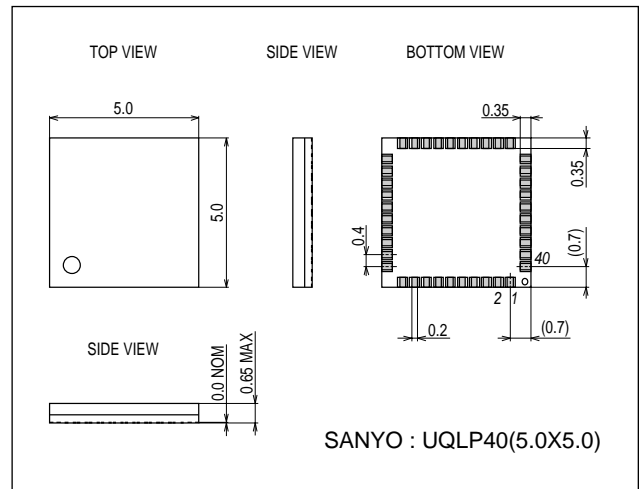
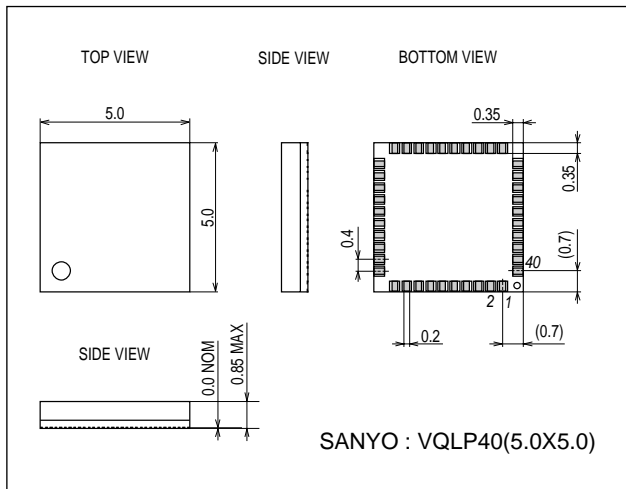

LV8044LP, LV8044LQ

Pin Assignment

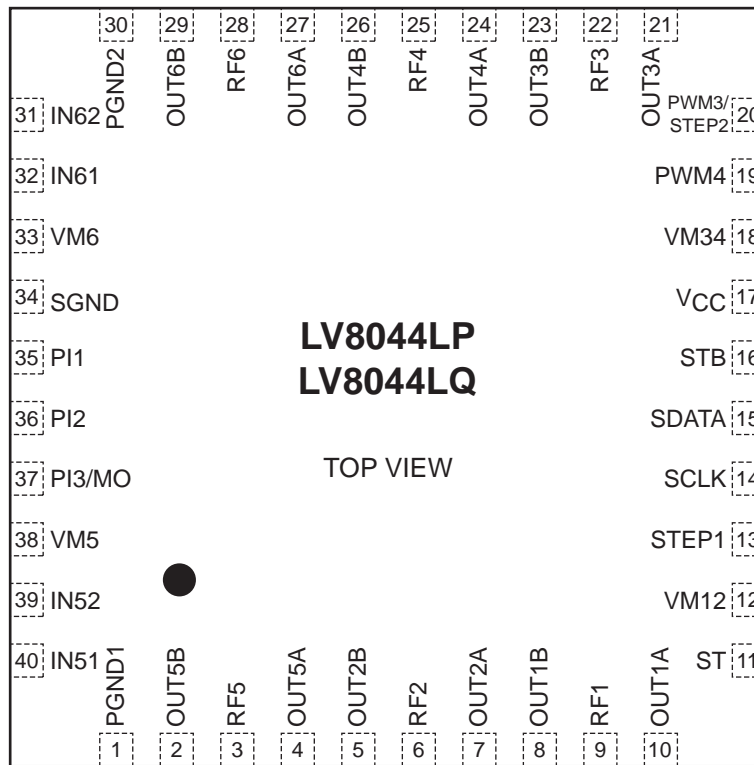

The pin assignment of LV8044LP and LV8044LQ is the same.

LV8044LP, LV8044LQ

Block Diagram

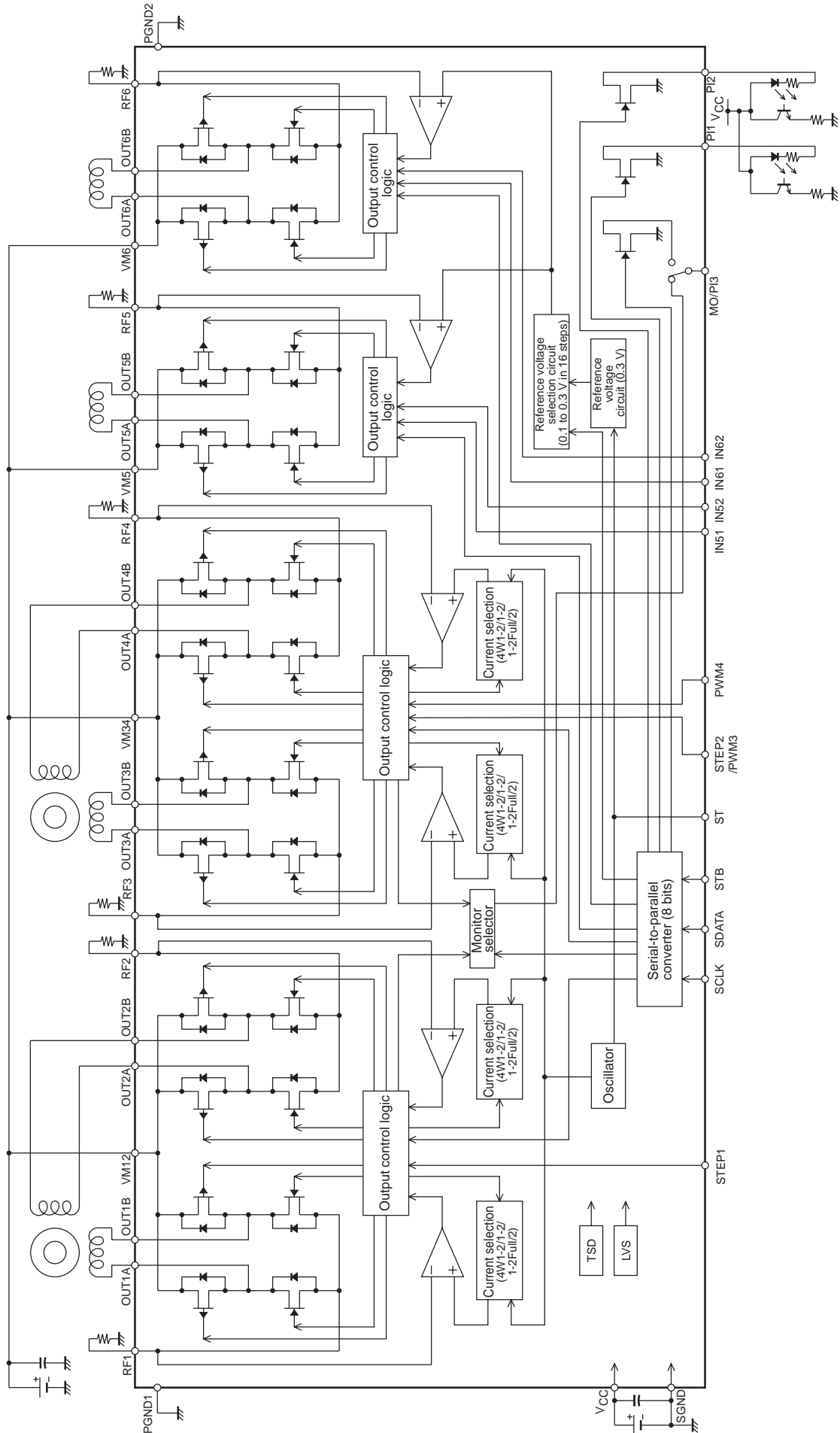

LV8044LP, LV8044LQ

Pin Function

Pin No.	Pin name	Function	Equivalent circuit	
13	STEP1	Channels 1/2 - STEP signal input		
20	PWM3/STEP2	3ch PWM signal input / Channels 3/4 - STEP signal input		
19	PWM4	4ch PWM signal input		
40	IN51	Channel 5 - Logic input 1		
39	IN52			
32	IN61	Channel 6- Logic input 1		
31	IN62			
14	SCLK	Serial data transfer clock input		
15	SDATA	Serial data input		
16	STB	Serial data latch pulse input		
11	ST	Chip enable		
10	OUT1A	1ch OUTA output		
7	OUT2A	2ch		
21	OUT3A	3ch		
24	OUT4A	4ch		
4	OUT5A	5ch		
27	OUT6A	6ch		
8	OUT1B	1ch OUTB output		
5	OUT2B	2ch		
23	OUT3B	3ch		
26	OUT4B	4ch		
2	OUT5B	5ch		
29	OUT6B	6ch		
9	RF1	1ch Current sensing resistor connection		
6	RF2	2ch		
22	RF3	3ch		
25	RF4	4ch		
3	RF5	5ch		
28	RF6	6ch		
12	VM12	Channels 1/2 - Motor power supply		
18	VM34	Channels 3/4 - Motor power supply		
38	VM5	Channels 5 - Motor power supply		
33	VM6	Channels 6 - Motor power supply		
35	PI1	Photosensor drive output		
36	PI2			

Continued on next page.

Continued from preceding page.

Pin No.	Pin name	Function	Equivalent circuit
37	PI3/MO	Photosensor drive output 3/position detection monitor	
17	V _{CC}	Logic system power supply	
1	PGND1	Channels 1/2/5 - Power system ground	
30	PGND2	Channels 3/4/6 - Power system ground	
34	SGND	Signal system ground	

Serial Data Input Specifications

1. Serial Data Input Setup

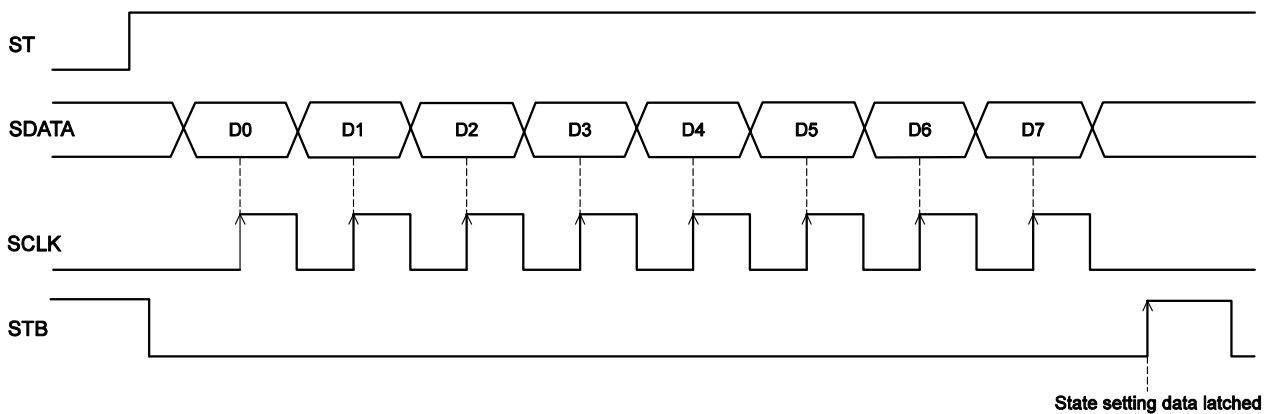

First set STB low and then input the SDATA and SCLK signals. The SCLK signal is not accepted when STB is high. SDATA inputs the data in the order D0, D1, ... D6, D7.

Data is transferred on the rising edge of SCLK and after all data has been transferred, all the data is latched on the rising edge of STB.

2. Timing with which the Serial Data Settings are Reflected in the Output

- STP timing mode (applies to microstep driver settings)
 - Type 1: The hold, reset, and enable settings, as well as the reference voltage setting are reflected at the same time as the STB signal data latch operation.
 - Type 2: The forward/reverse (FR) and the excitation setting mode (MS) setting that are set at STP setup are reflected in the output at the next clock rising edge after data latch.
- STB timing (applies to settings other than the above)

Type 1: The PWM driver, constant-current driver, PI, and other settings are reflected at the same time as the STB signal data latch operation.

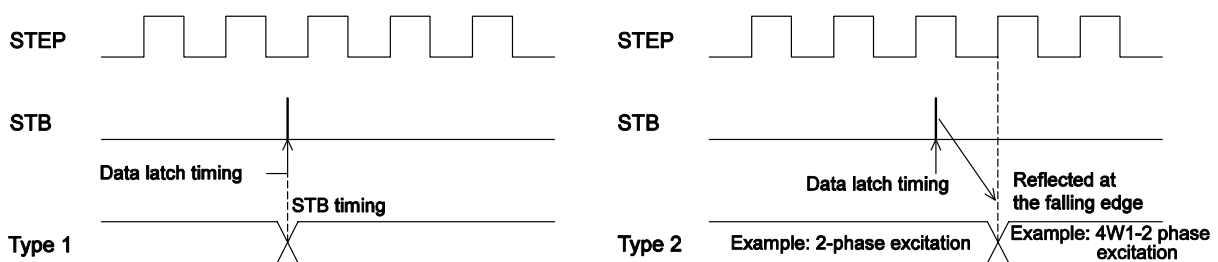

LV8044LP, LV8044LQ

Serial Data Truth Table

Serial Logic Table (1)

Input							Setting mode	Description	Remarks	Set channel						PI	Serial data reflection timing							
D0	D1	D2	D3	D4	D5	D6				D7	1ch	2ch	3ch	4ch	5ch		6ch	STEP1	STEP2	STB				
0	0	0	0	0	*	*	*	Channels 1 and 2 excitation mode selection	2 phase		○	○						○						
			1	0	*	*	*		1-2 phase (full torque)															
			0	1	*	*	*		1-2 phase															
			1	1	*	*	*		4W1-2 phase															
			*	*	0	0	*	Channels 1 and 2 current reference voltage selection	100% (0.2V)															
			*	*	1	0	*		67% (0.134V)															
			*	*	0	1	*		50% (0.1V)															
			*	*	1	1	*		33% (0.066V)															
			*	*	*	*	*	(Dummy data)																
			*	*	*	*	1																	
1	0	0	0	*	*	*	*	1/2ch energization direction	CW (Forward)		○	○							○					
			1	*	*	*	*		CCW (Reverse)															
			*	0	*	*	*	1/2ch step hold	Cancel															
			*	1	*	*	*		Hold															
			*	*	0	*	*	1/2ch counter reset	Reset															
			*	*	1	*	*		Cancel															
			*	*	*	0	*	1/2ch output enable	Output OFF															
			*	*	*	1	*		Output ON															
			*	*	*	*	0	(Dummy data)																
			*	*	*	*	1																	

LV8044LP, LV8044LQ

Serial Logic Table (4)



Input							Setting mode	Description	Remarks	Set channel						PI	Serial data reflection timing			
D0	D1	D2	D3	D4	D5	D6				D7	1ch	2ch	3ch	4ch	5ch		6ch	STEP1	STEP2	STB
0	1	1	0	*	*	*	*	Photo-sensor drive 1	OFF											
			1	*	*	*	*		ON											
			*	0	*	*	*	*	Photo-sensor drive 2	OFF										
			*	1	*	*	*	*		ON										
			*	*	*	0	*	*	Photo-sensor drive 3 (When PI3 output selected)	OFF										
			*	*	*	1	*	*		ON										
			*	*	*	*	0	*	(Dummy data)											
			*	*	*	*	1	*												
			*	*	*	*	*	0	(Dummy data)											
			*	*	*	*	*	1												
1	1	1	0	*	*	*	*	PI3/MO select	PI3 Output											
			1	*	*	*	*		MO output											
			*	0	*	*	*	*	MO output channel selection (When MO output selected)	1/2ch	*3									
			*	1	*	*	*	*		3/4ch										
			*	*	*	0	*	*	MO output position	Initial position	*4									
			*	*	*	1	*	*		1-2 phase										
			*	*	*	*	0	0	Chopping frequency setting	130KHz										
			*	*	*	*	1	0		65KHz										
			*	*	*	*	0	1		200KHz										
			*	*	*	*	1	1		100KHz										

Notes

- *1: This serial data is only accepted when the IN51/IN52 pulse inputs are in the Low/Low states, respectively. It is ignored at all other times.
- *2: This serial data is only accepted when the IN61/IN62 pulse inputs are in the Low/Low states, respectively. It is ignored at all other times.
- *3: When D4 = 1, MO is only output if microstep mode is selected for channels 3 and 4. In PWM mode, this output is held fixed at the high level.
- *4: The MO output can be specified to be the 1-2 phase position only in 4W1-2 phase excitation mode. In all other excitation modes, the MO output position becomes the initial position regardless of the serial data values.

Channels 1 and 2 Driver Circuit (Microstep drive stepping mode driver)

STEP1 Pin Function

Input		Operating mode
ST	STEP1	
Low	*	Standby mode
High		Excitation step feed
High		Excitation step hold

Excitation Mode Setting (D0 = 0, D1 = 0, D2 = 0)

D3	D4	Excitation mode	Initial position	
			1ch	2ch
0	0	2 phase excitation	100%	-100%
1	0	1-2 phase excitation (full torque)	100%	0%
0	1	1-2 phase excitation	100%	0%
1	1	4W1-2 phase excitation	100%	0%

The initial state at power on is the initial position for each excitation mode when the counter is reset.

Reference Voltage Setting Serial Data: (D0 = 0, D1 = 0, D2 = 0)

D5	D6	Current setting reference voltage (When microstep is 100%)
0	0	0.2V
1	0	0.134V
0	1	0.1V
1	1	0.066V

The output current setting reference voltage can be switched between four levels with the serial data. This setting is useful for saving power in the motor powered hold state.

Calculating the Set Current

Since the reference voltage can be modified (0.2, 0.134, 0.1, and 0.66V) with the serial data, the output current can be set with the reference voltage and the resistor RF connected between the RF pin and ground.

$$I_{OUT} = (<reference\ voltage> \times <set\ current\ ratio>)/<RF\ resistor\ value>$$

Example: If the reference voltage is 0.2 V, the set current ratio is 100%, and the RF resistor value is 1Ω, then the output current will be that shown below.

$$I_{OUT} = 0.2V \times 100\%/1\Omega = 200mA$$

LV8044LP, LV8044LQ

Output Current Vector Locus (With one step normalized to 90 degrees)

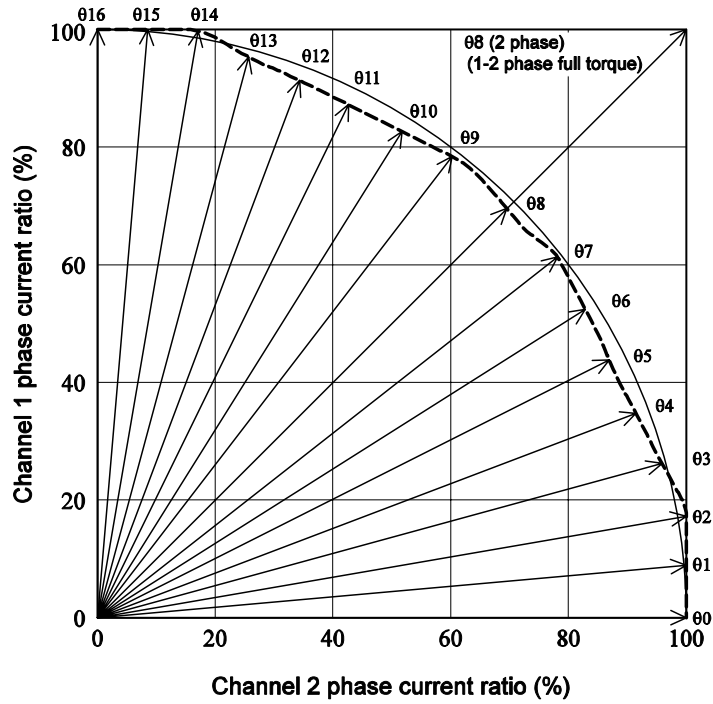

Set Current Ratios in the Different Excitation Modes

STEP	4W1-2 phase (%)		1-2 phase (%)		1-2 phase full torque (%)		2 phase (%)	
	1ch	2ch	1ch	2ch	1ch	2ch	1ch	2ch
00	0	100	0	100	0	100		
01	10	100						
02	20	100						
03	30	96.5						
04	39.5	93.0						
05	48.5	89						
06	57.5	85.5						
07	65.5	81.5						
08	74.0	74.0	74.0	74.0	100	100	100	100
09	81.5	65.5						
010	85.5	57.5						
011	89	48.5						
012	93.0	39.5						
013	96.5	30						
014	100	20						
015	100	10						
016	100	0	100	0	100	0		

2 Phase Excitation (CW mode)

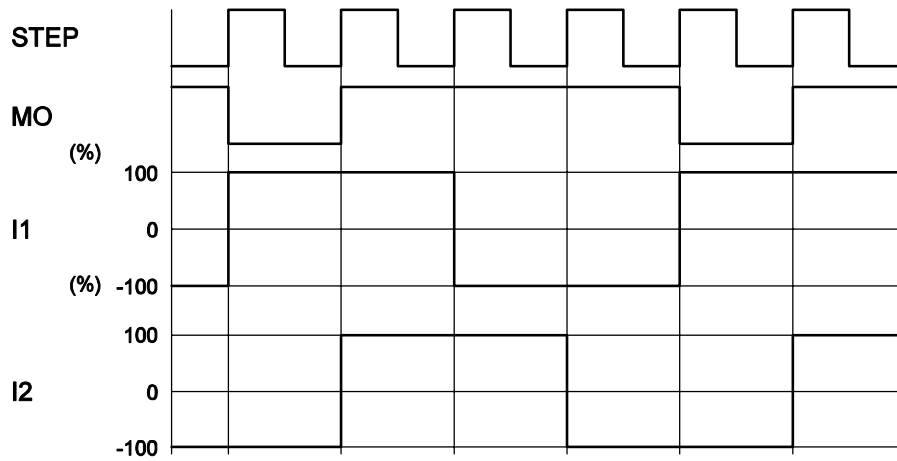

2 Phase Excitation full torque (CW mode)

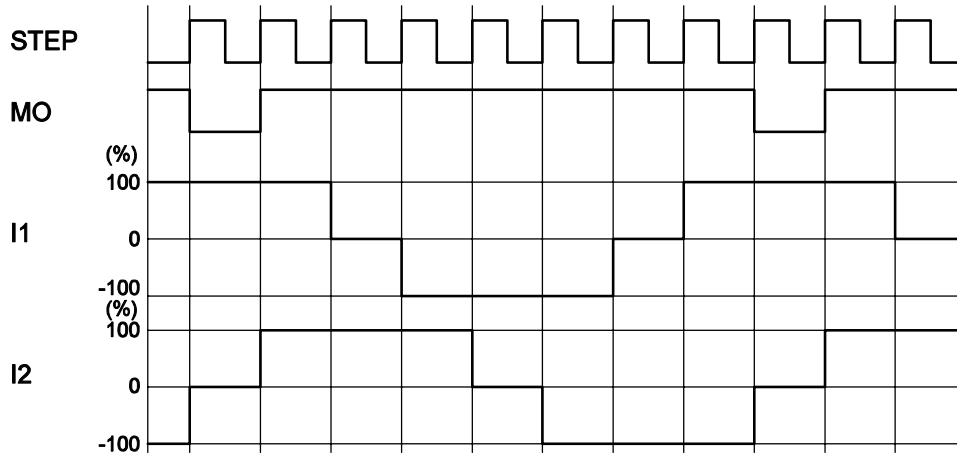

1 2-Phase Excitation (CW mode)

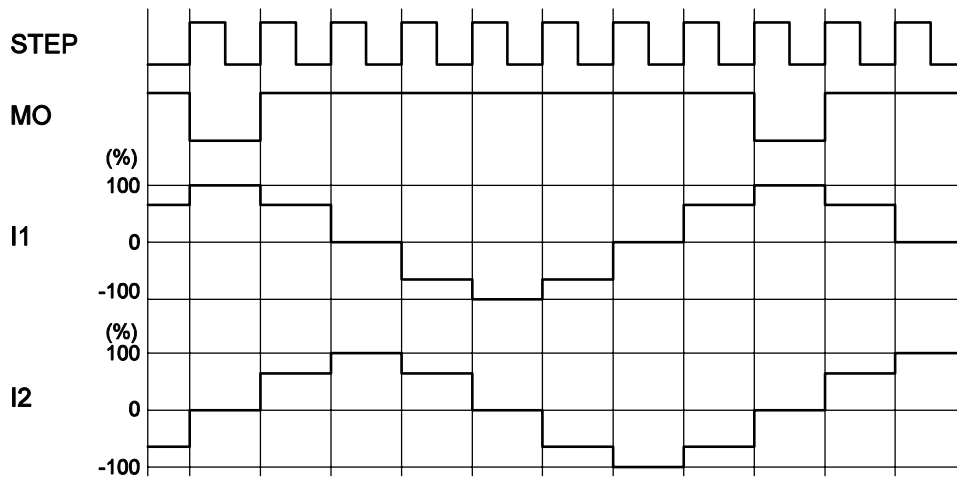

4W1-2 Phase Excitation (CW mode)

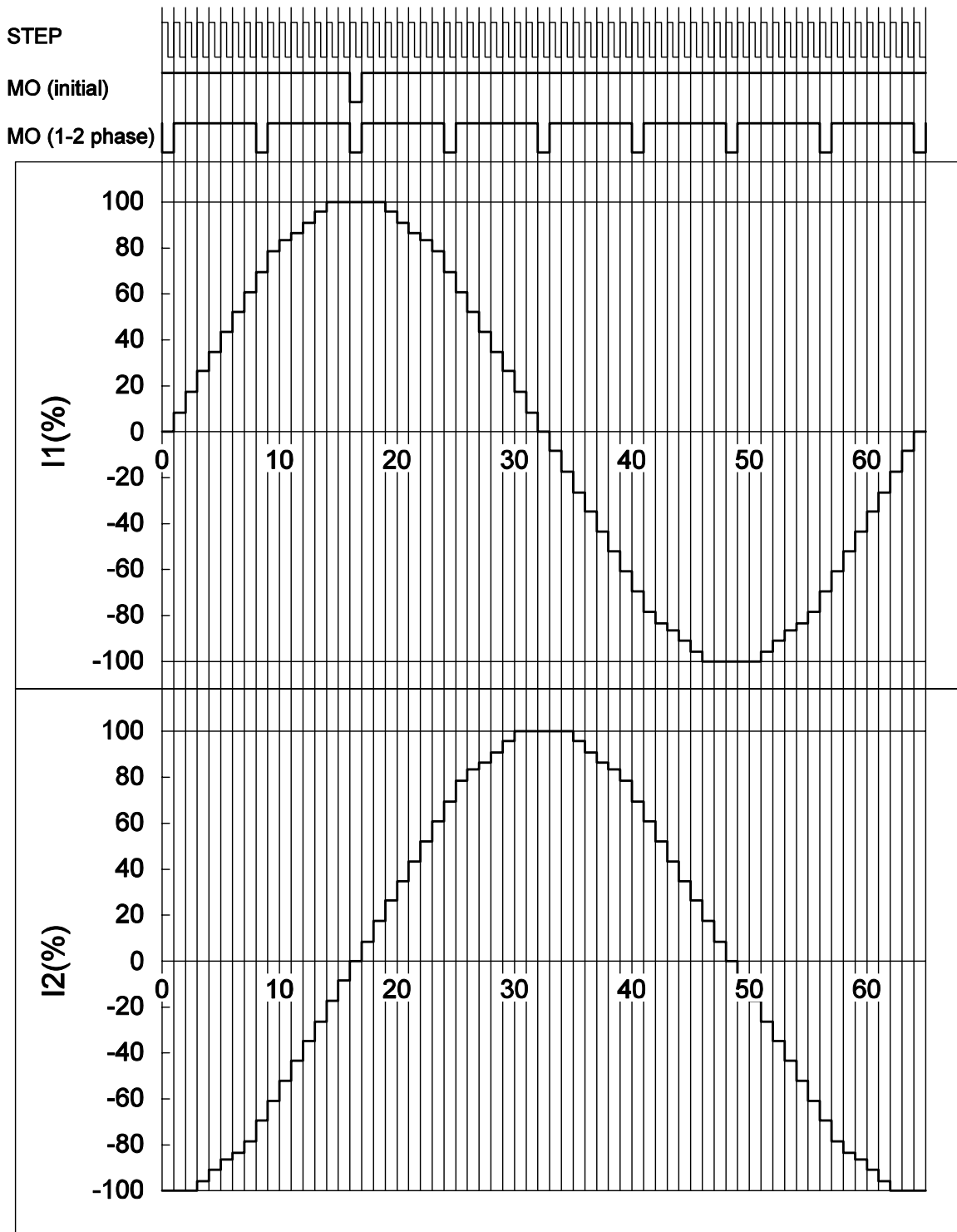

Current Control Operation Specifications

- Sine wave increasing direction

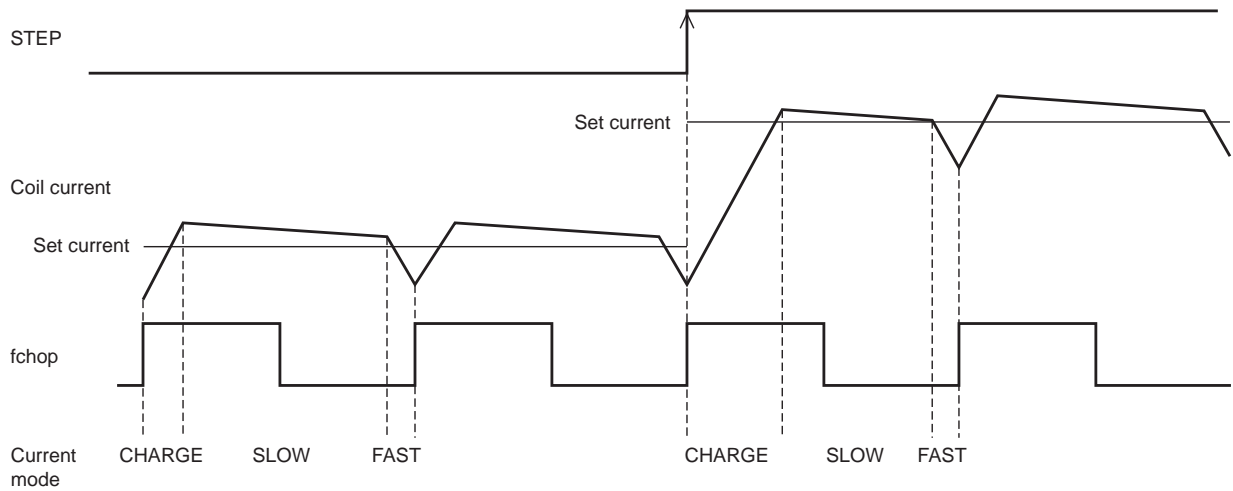

- Sine wave decreasing direction

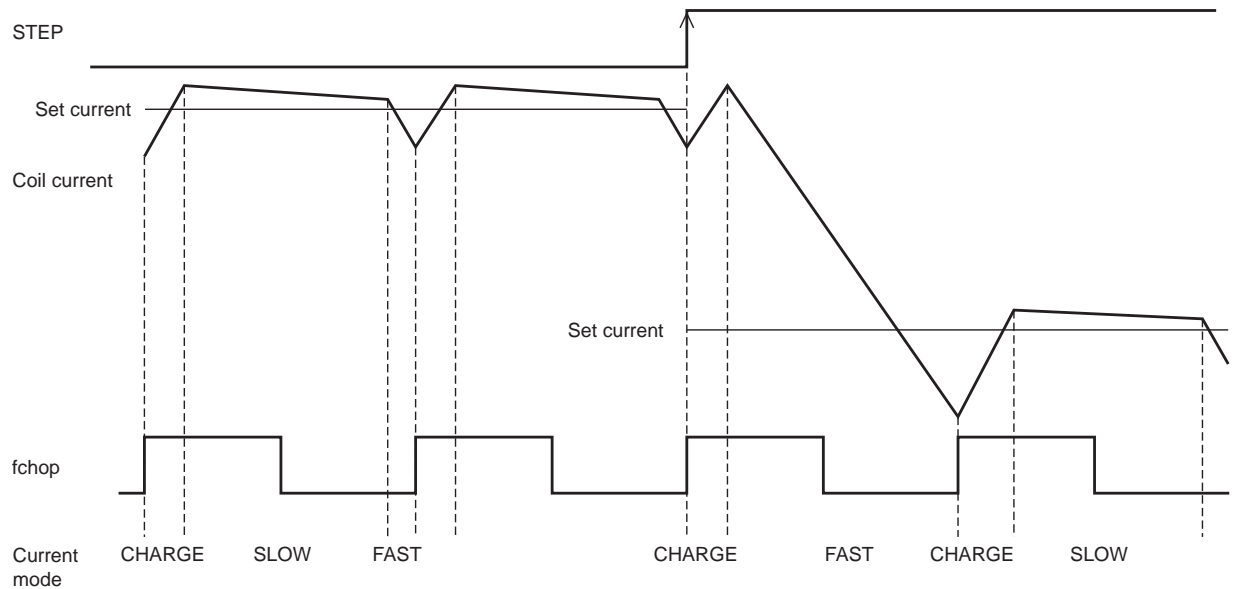

Each of the current modes operates with the follow sequence.

- The IC enters charge mode when the chopping oscillation starts. (A period of charge mode is forcibly present in 1/8 of the period, regardless of which of the coil current (ICOIL) and the set current (IREF) is larger.)
- In charge mode, the coil current (ICOIL) and the set current (IREF) are compared.

If an $ICOIL < IREF$ state exists during the charge period:

The IC operates in charge mode until $ICOIL \geq IREF$. After that, it switches to slow decay mode and then switches to fast decay mode in the last 1/8 of the period.

If no $ICOIL < IREF$ state exists during the charge period:

The IC switches to fast decay mode and the coil current is attenuated with the fast decay operation until the end of the chopping period.

The above operation is repeated. Normally, in the sine wave increasing direction the IC operates in slow (+fast) decay mode, and in the sine wave decreasing direction the IC operates in fast decay mode until the current is attenuated and reaches the set value and the IC operates in slow decay mode.

LV8044LP, LV8044LQ

Chopping Frequency Setting (D6 and D7 in the serial data)

This IC integrates an internal oscillator circuit and allows the chopping frequency used in constant-current control to be switched with the serial data (111***, D6, D7) setting.

Data D6	Data D7	Chopping frequency
0	0	130KHz
1	0	65KHz
0	1	200KHz
1	1	100KHz

Monitor Output Setting (Serial data bits D3, D4, and D5)

The signal output from the PI3/MO pin can be switched with the serial data (111, D3, ****) setting.

Data D3	PI3/MO pin output
0	Photosensor drive output 3
1	Stepping position detection monitor output

It is also possible to select which of channels 1 and 2 or channels 3 and 4 are output from the monitor pin with the serial data (111*, D4, D5, **) setting. The MO output position used to detect the driver excitation position in microstepping drive mode can also be switched. The state MO = Low is output at the output position.

Data D4	Data D5	Channels 1 and 2 excitation mode	Channels 3 and 4 excitation mode	MO output
0	0	2 phase excitation		Channels 1 and 2 monitor/initial position
0	1			Channels 1 and 2 monitor/initial position
0	0	1-2 phase excitation (full torque)		Channels 1 and 2 monitor/initial position
0	1			Channels 1 and 2 monitor/initial position
0	0	2 phase excitation		Channels 1 and 2 monitor/initial position
0	1			Channels 1 and 2 monitor/initial position
0	0	4W1-2 phase excitation		Channels 1 and 2 monitor/initial position
0	1			Channels 1 and 2 monitor/1-2 phase position
1	0		2 phase excitation	Channels 3 and 4 monitor/initial position
1	1			Channels 3 and 4 monitor/initial position
1	0		1-2 phase excitation (full torque)	Channels 3 and 4 monitor/initial position
1	1			Channels 3 and 4 monitor/initial position
1	0		2 phase excitation	Channels 3 and 4 monitor/initial position
1	1			Channels 3 and 4 monitor/initial position
1	0		4W1-2 phase excitation	Channels 3 and 4 monitor/initial position
1	1			Channels 3 and 4 monitor/1-2 phase position
1	0		PWM drive mode	Output held fixed at the high level
1	1			Output held fixed at the high level

LV8044LP, LV8044LQ

Basic Set Current Step Switching (STEP pin) and Forward/Reverse Switching (D3 in the serial data) Operations

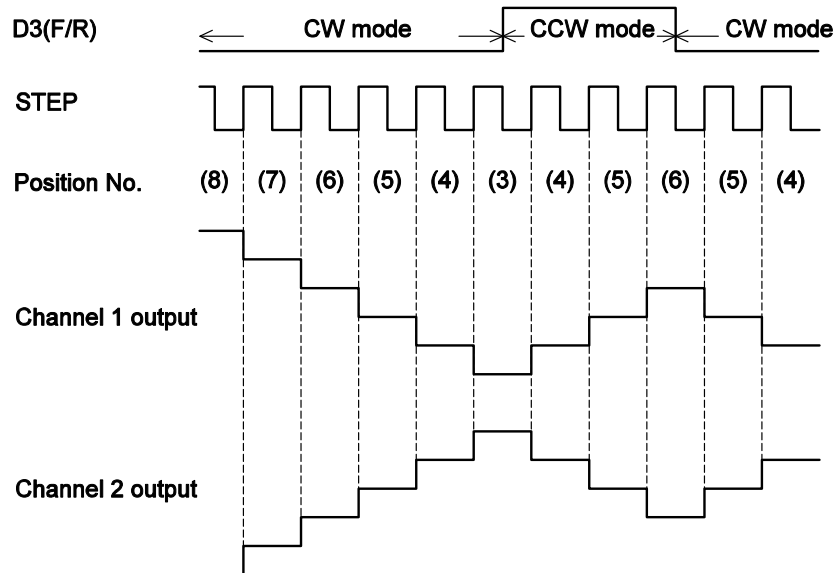
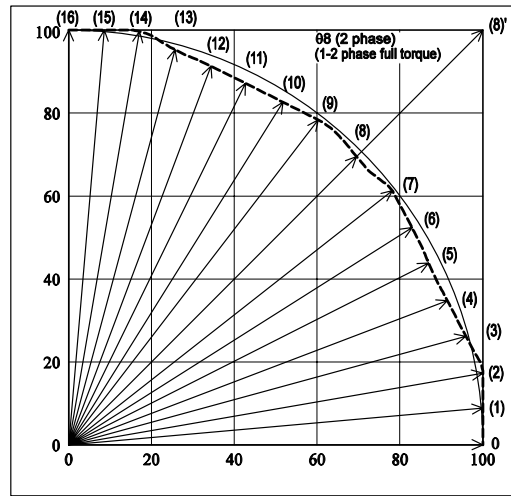

The IC internal D/A converter advances by 1 bits on the rising edge of the input step pulse.

The CW/CCW mode can be switched with the serial data (100, D3, ****) setting. The operation progresses with the position number decreasing in CW mode and increasing in CCW mode.

In CW mode, the channel 2 current phase is delayed by 90 degrees relative to the channel 1 current.

In CCW mode, the channel 2 current phase is advanced by 90 degrees relative to the channel 1 current.

LV8044LP, LV8044LQ

Excitation Mode Switching During Operation (D3 and D4 in the serial data)

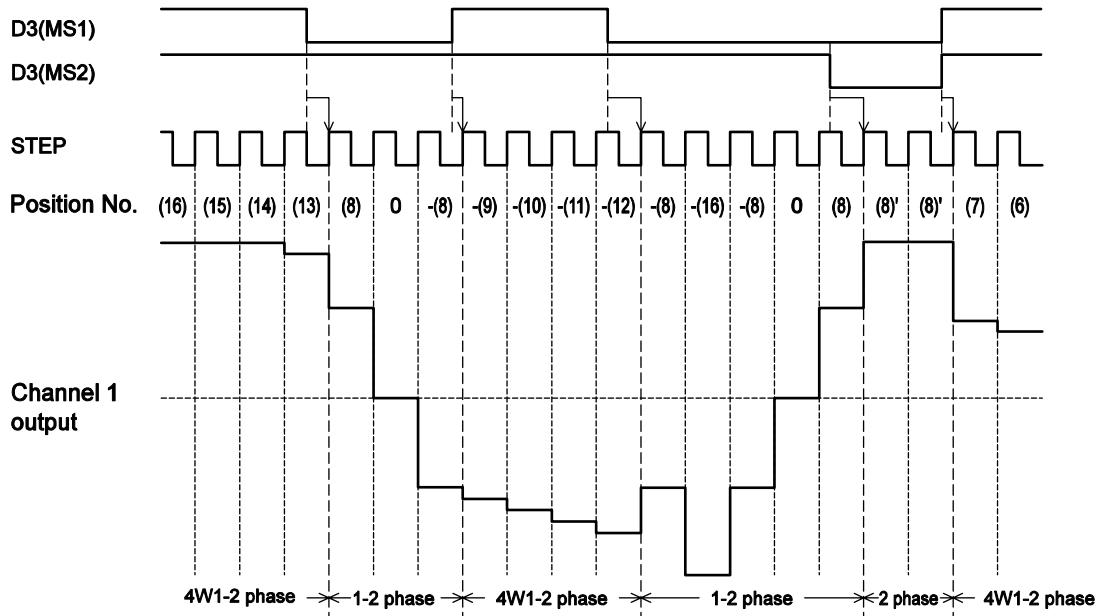

If the excitation mode is switched when power is applied to the motor, the operation follows the sequence shown below. (CW mode)

Before excitation mode switching		Step position after excitation mode switching			
Excitation mode	Position	4W1-2 phase	1-2 phase	2 phase full torque	2 phase
4W1-2 phase	(16)	/	(8)	(8)'	(8)'
	(15) to (9)		(8)	(8)'	(8)'
	(8)		0	0	(8)'
	(7) to (1)		(8)	(8)'	(8)'
	0		(-8)	(-8)'	(-8)'
1-2 phase	(16)	(15)	/	(8)'	(8)'
	(8)	(7)		0	(8)'
	0	(-1)		(-8)'	(-8)'
2 phase full torque	(16)	(15)	(8)	/	(8)'
	(8)'	(7)	0		(8)'
	0	(-1)	(-8)		(-8)'
2 phase	(8)'	(7)	0	0	/

Output Enable Function (D6 in the serial data)

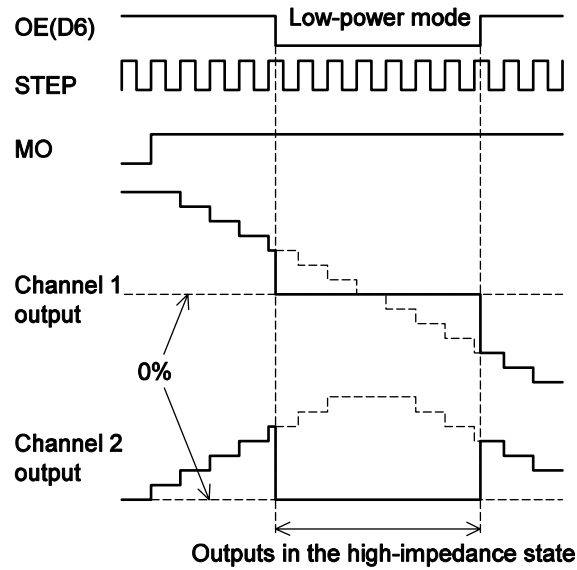

When the OE bit in the serial data, D6 (100, ***, D6, *), is set to 0, the output is turned off and set to the high-impedance state at the rise of STB.

Since, however, the internal logic circuits operate in this state, the position number will be advanced if a step input is applied. Therefore, when the OE bit (D6) is returned to 1, a level according to the position number advanced by the step input will be output.

Counter Reset Function (D5 in the serial data)

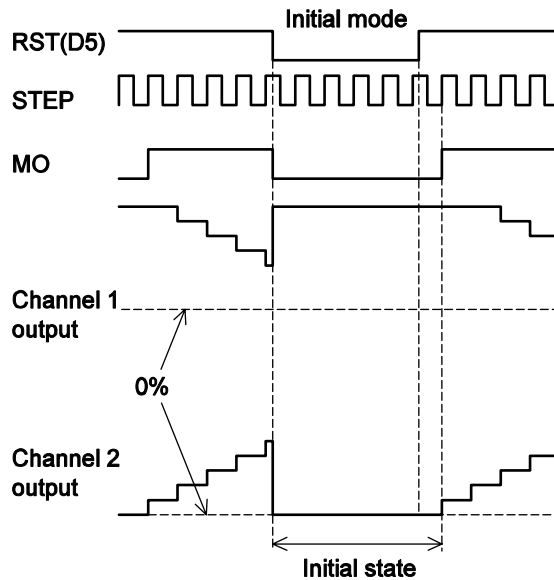

When the reset bit in the serial data, D5 (100, **, D5, **), is set to 0, the output goes to the initial state at the rise of STB and the MO output goes low.

Then, when the reset bit (D5) is next set to 1, the position number will advance at the next step input.

Step Hold Function (D4 in the serial data)

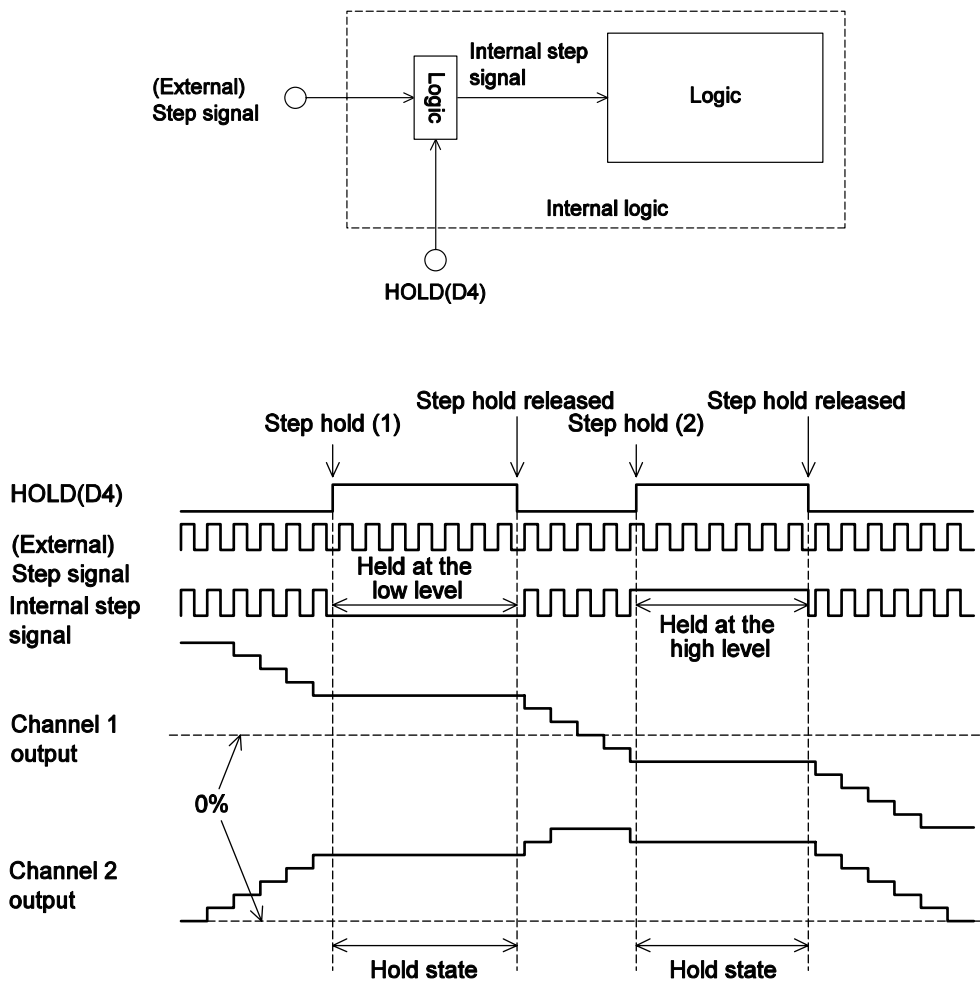

When the hold bit in the serial data, D4 (100, *, D4, ***), is set to 1, the external step state at that time is held without change as the internal step state.

Since the (external) step state is low at the timing of the step hold operation (1) in the figure, the internal step state is held at the low level, and since the (external) step state is high at the timing of the step hold operation (1), the internal step state is held at the high level.

When the hold data (D) is set to 0, the internal state is synchronized with the external step signal.

The output is held at the state at the point where the step hold was applied and after the step hold is released, it advances with the timing of the next step input (rising edge).

As long as the IC is in the hold state, the position number does not advance even if external step pulses are applied.

Channels 3 and 4 Driver Circuit (Saturated drive/microstep drive)

Driver Mode Setting (D0 = 0, D1 = 1, D2 = 0)

D7 data value	Drive mode	Pin functions	Notes
0	Saturated drive	PWM3	Used as the channel 3 PWM input pin
1	Microstep drive	STEP2	Used as the channels 3 and 4 excitation step input pin

The channels 3 and 4 driver circuit can be switched between the following operating modes by bit D7 in the serial data (010, ***, D7).

- (1) Two saturated mode driver channels
- (2) One microstep drive stepping motor driver channel

Microstep Drive Stepping Motor Driver

The basic functionality provided is identical to that of the channels 1 and 2 stepping motor driver. See section 10-2 for details on the serial data settings.

PWM Saturated Mode Driver

Channel 3 Truth Table (PWM mode: D0 = 1, D1 = 1, D2 = 0)

Input					Output		Operating mode
ST	PWM3	D3	D4	D7	OUT3A	OUT3B	
Low	*	*	*	*	OFF	OFF	Standby mode
High	Low	0	0	*	OFF	OFF	Output off
High	Low	1	0	*	High	Low	CW (forward)
High	Low	0	1	*	Low	High	CCW (reverse)
High	Low	1	1	*	Low	Low	Brake
High	High	*	*	0	Low	Low	SLOW DECAY (brake)
High	High	*	*	1	OFF	OFF	FAST DECAY (output off)

Channel 4 Truth Table (PWM mode: D0 = 1, D1 = 1, D2 = 0)

Input					Output		Operating mode
ST	PWM4	D5	D6	D7	OUT4A	OUT4B	
Low	*	*	*	*	OFF	OFF	Standby mode
High	Low	0	0	*	OFF	OFF	Output off
High	Low	1	0	*	High	Low	CW (forward)
High	Low	0	1	*	Low	High	CCW (reverse)
High	Low	1	1	*	Low	Low	Brake
High	High	*	*	0	Low	Low	SLOW DECAY (brake)
High	High	*	*	1	OFF	OFF	FAST DECAY (output off)

*: Don't care

Channels 5 and 6 Driver Circuit (Constant-current drive)

Output Function

When the channels 5 and 6 driver circuit is used to drive an actuator, it can be controlled either from the serial data or from the IN51, IN52, IN61, and IN62 parallel signals.

When the parallel input signals IN51 (IN61)/IN52 (IN62) are in the low/low state (note that since these inputs are pulled down internally in the IC, the open/open state can also be used), the output mode will be determined by the serial data.

If the parallel input signals are in any state other than the above, the serial data will be ignored and the output mode will be determined by the parallel inputs.

Truth Table (Channel 5: D0 = 1, D1 = 0, D2 = 1)

Parallel input		Serial data		Outputs		Mode
IN51	IN52	D3	D4	OUT5A	OUT5B	
Low	Low	0	0	OFF	OFF	Standby mode
		1	0	High	Low	CW (forward)
		0	1	Low	High	CCW (reverse)
		1	1	Low	Low	Brake
High	Low	*	*	High	Low	CW (forward)
Low	High	*	*	Low	High	CCW (reverse)
High	High	*	*	Low	Low	Brake

Truth Table (Channel 6: D0 = 0, D1 = 0, D2 = 1)

Parallel input		Serial data		Outputs		Mode
IN61	IN62	D5	D6	OUT6A	OUT6B	
Low	Low	0	0	OFF	OFF	Standby mode
		1	0	High	Low	CW (forward)
		0	1	Low	High	CCW (reverse)
		1	1	Low	Low	Brake
High	Low	*	*	High	Low	CW (forward)
Low	High	*	*	Low	High	CCW (reverse)
High	High	*	*	Low	Low	Brake

*: Don't care

Constant-Current Control

Reference Voltage Setting (D0 = 1, D1 = 0, D2 = 1, D3 = 0 (channel 5) or D3 = 1 (channel 6))

D4	D5	D6	D7	Current setting reference voltage
0	0	0	0	0.300V
1	0	0	0	0.200V
0	1	0	0	0.190V
1	1	0	0	0.180V
0	0	1	0	0.170V
1	0	1	0	0.165V
0	1	1	0	0.160V
1	1	1	0	0.155V
0	0	0	1	0.150V
1	0	0	1	0.145V
0	1	0	1	0.140V
1	1	0	1	0.135V
0	0	1	1	0.130V
1	0	1	1	0.120V
0	1	1	1	0.110V
1	1	1	1	0.100V

The constant-current setting for channels 5 and 6 can be set individually for each channel.
 (When D3 is 0, channel 5 is set, and when D3 is 1, channel 6 is set.)

The constant-current output value is set by the constant-current reference voltage set with the serial data and the value of the resistor (referred to as "RF" here) connected to the RF5 or RF6 pin.
 The formula below is used to calculate the constant-current output value.

$$\langle \text{Constant-current output level} \rangle = \langle \text{current setting reference voltage} \rangle / \langle \text{RF resistor} \rangle$$

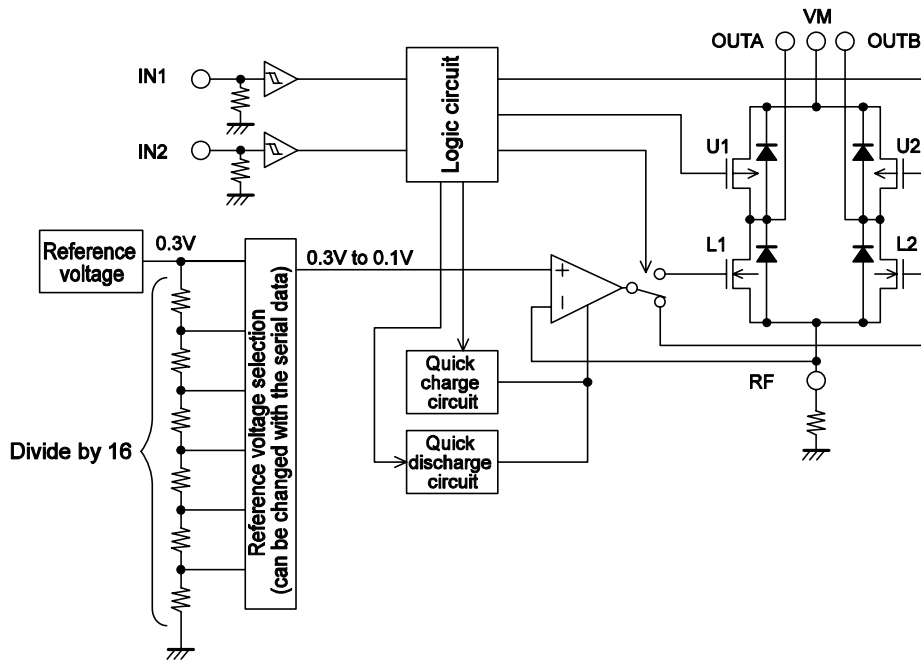

Photosensor Drive Circuit (PI1, PI2, and PI3)

The photosensor drive circuit has open-drain outputs. The output is controlled (set to on or off) by a bit in the serial data (0 or 1).

Truth Table

ST	Input			Output			Drive circuit
	D3	D4	D5	PI1	PI2	PI3	
Low	*	*	*	OFF	OFF	OFF	Standby mode
High	0	*	*	OFF	*	*	Off
High	1	*	*	Low	*	*	On
High	*	0	*	*	OFF	*	Off
High	*	1	*	*	Low	*	On
High	*	*	0	*	*	OFF	Off
High	*	*	1	*	*	Low	On

- SANYO Semiconductor Co.,Ltd. assumes no responsibility for equipment failures that result from using products at values that exceed, even momentarily, rated values (such as maximum ratings, operating condition ranges, or other parameters) listed in products specifications of any and all SANYO Semiconductor Co.,Ltd. products described or contained herein.
- SANYO Semiconductor Co.,Ltd. strives to supply high-quality high-reliability products, however, any and all semiconductor products fail or malfunction with some probability. It is possible that these probabilistic failures or malfunction could give rise to accidents or events that could endanger human lives, trouble that could give rise to smoke or fire, or accidents that could cause damage to other property. When designing equipment, adopt safety measures so that these kinds of accidents or events cannot occur. Such measures include but are not limited to protective circuits and error prevention circuits for safe design, redundant design, and structural design.
- In the event that any or all SANYO Semiconductor Co.,Ltd. products described or contained herein are controlled under any of applicable local export control laws and regulations, such products may require the export license from the authorities concerned in accordance with the above law.
- No part of this publication may be reproduced or transmitted in any form or by any means, electronic or mechanical, including photocopying and recording, or any information storage or retrieval system, or otherwise, without the prior written consent of SANYO Semiconductor Co.,Ltd.
- Any and all information described or contained herein are subject to change without notice due to product/technology improvement, etc. When designing equipment, refer to the "Delivery Specification" for the SANYO Semiconductor Co.,Ltd. product that you intend to use.
- Information (including circuit diagrams and circuit parameters) herein is for example only; it is not guaranteed for volume production.
- Upon using the technical information or products described herein, neither warranty nor license shall be granted with regard to intellectual property rights or any other rights of SANYO Semiconductor Co.,Ltd. or any third party. SANYO Semiconductor Co.,Ltd. shall not be liable for any claim or suits with regard to a third party's intellectual property rights which has resulted from the use of the technical information and products mentioned above.

This catalog provides information as of January, 2008. Specifications and information herein are subject to change without notice.