

## SiGe Transmit / Receive Front End IC

### Description

The T0980 is a monolithic SiGe transmit/ receive front end IC with power amplifier & low noise amplifier.

Electrostatic sensitive device.

Observe precautions for handling.



### Features

- High power added efficient power amplifier (Pout typ. 29 dBm)
- Low noise preamplifier (NF typ. 1.7 dB)
- Controlled output power
- Few external components
- PSSO16 plastic package with down set paddle

### Block Diagram

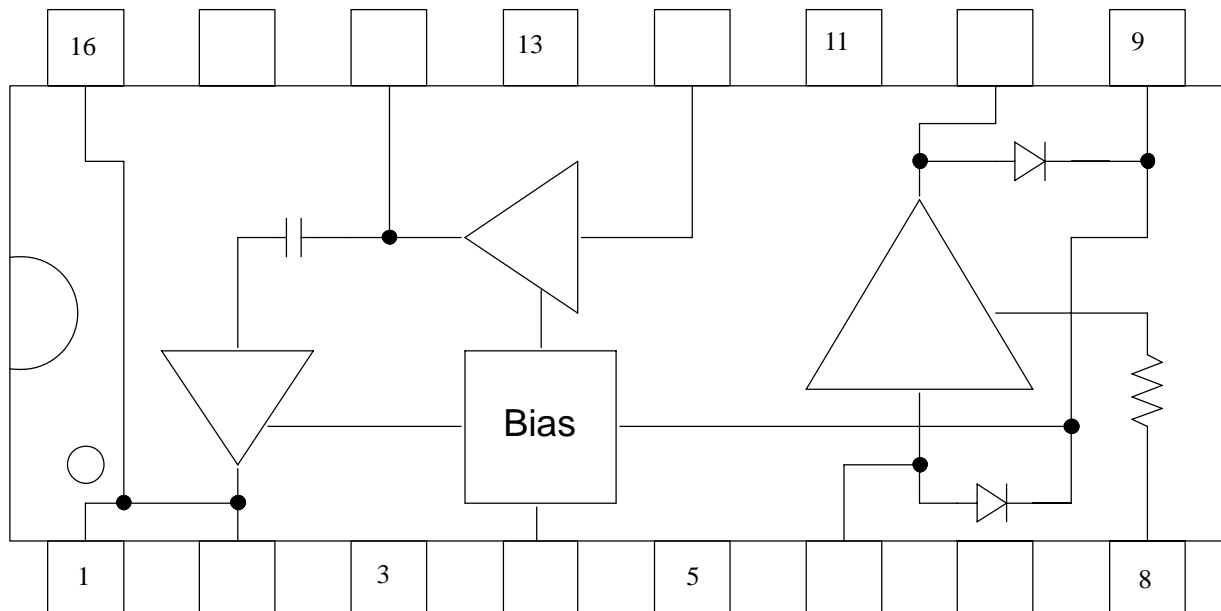

Figure 1. Block diagram

### Ordering Information

Extended Type Number	Package	Remarks
T0980-TJS	PSSO16	Tube
T0980-TJQ	PSSO16	Taped and reeled

## Pin Description

Pin	Symbol	Function
1	V2_PA_OUT	Inductor to power supply and matching network for power amplifier output
2	V2_PA_OUT	Inductor to power supply and matching network for power amplifier output
3	GND	Ground
4	POUT_CONTROL	Power amplifier control input
5	GND	Ground
6	LNA_IN	Low noise amplifier input
7	GND	Ground
8	BIAS_LNA	Resistor to $V_s$ sets the LNA current
9	VS_CTRL	Supply voltage for control of power amplifier
10	LNA_OUT	Low noise amplifier output and supply voltage
11	GND	Ground
12	PA_IN	Power amplifier input
13	GND	Ground
14	V1_PA	Supply voltage for power amplifier
15	GND	Ground
16	V2_PA_OUT	Matching network for power amplifier output

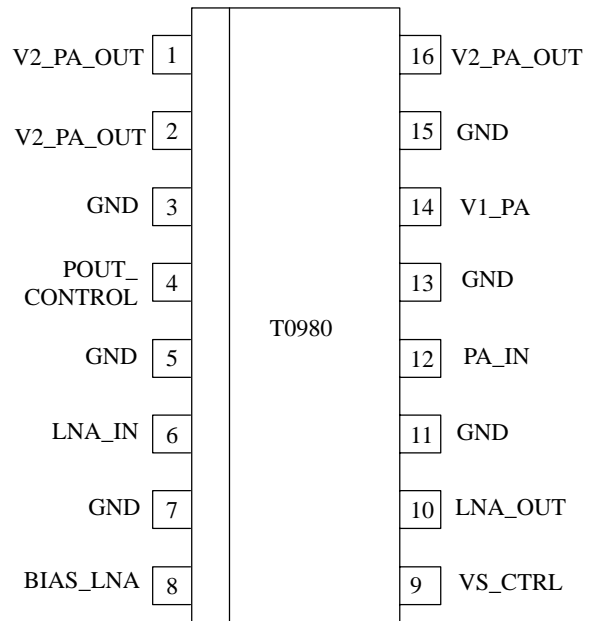

Figure 2. Pinning PSSO16

## Absolute Maximum Ratings

All voltages are referred to GND

Parameter	Symbol	Min.	Max.	Unit
Supply voltage PA, TX	$V_{s\_PA}$		4.5	V
Supply voltage LNA, RX	$V_{s\_LNA}$		2.8	V
Junction temperature	$T_{jmax}$		150	°C
Storage temperature	$T_{stg}$	-55	+125	°C

## Operating Range

All voltages are referred to GND. The following table represents the sum of all supply currents.

Parameter	Test Conditions / Pins	Symbol	Min.	Typ.	Max.	Unit
Supply voltage PA	TX, Pins 1, 2, 9 and 14	$V_{s\_PA}$		3.6	4.4	V
Supply voltage LNA	RX, Pin 10	$V_{s\_LNA}$		2.5	2.6	V
Supply current PA	TX, Pins 1, 2, 9 and 14	$I_{s\_PA}$		400		mA

## Operating Range (continued)

All voltages are referred to GND. The following table represents the sum of all supply currents.

Parameter	Test Conditions / Pins	Symbol	Min.	Typ.	Max.	Unit
Supply current LNA	Pins 10 and 8	Is_LNA		2.5		mA
Ambient temperature		Tamb	-25	25	60	°C

## Thermal Resistance

Parameter	Symbol	Value	Unit
Junction ambient	R <sub>thJA</sub>	25	K/W

**ESD Protection: t.b.d.**

## Electrical Characteristics

Test conditions (unless otherwise specified) : Vs\_PA = 3.6 V, Tamb = 25 °C.

Parameter	Test Conditions / Pins	Symbol	Min.	Typ.	Max.	Unit
<b>Power amplifier <sup>1)</sup></b>						
Supply voltage	TX, Pins 1, 2, 9 and 14	Vs_PA		3.6		V
Supply current	TX, Pins 1, 2, 9 and 14	Is_PA		400		mA
Frequency range	TX	f	400		500	MHz
Power gain	TX	Gp		33		dB
Control voltage	TX, output power (max), Pin 4			2.5		V
	TX, output power (min), Pin 4			0.7		V
Control current	Pin 4		0		400	μA
Shut-down mode	Control voltage ≤ 0.1 V, Pins 1, 2, 9 and 14	Is_PA		10		μA
Power added efficiency	TX @ 450 MHz	PAE	50			%
Saturated output power	TX, input power 3 dBm	Psat		29		dBm
Harmonics	TX, input power 3 dBm	2 fo		-20		dBc
	TX, input power 3 dBm	3 fo		-20		dBc
<b>Low-noise amplifier</b>						
Supply voltage	RX, Pins 8 and 10	Vs_LNA		2.5		V
Supply current	RX @ R1 = 5.6 kΩ, Pins 8 and 10	Is_LNA		2.5		mA
Frequency range	RX	f	400		500	MHz
Power gain	RX @ R1 = 5.6kΩ, Is=2.5 mA	Gp		19		dB
Noise figure	RX @ R1 = 5.6 kΩ, Is=2.5 mA	NF		1.7	2.5	dB
Isolation	RX @ R1 = 5.6 kΩ, Is=2.5 mA	ISO		20		dB
3rd-order input inter-ception point	RX @ R1 = 5.6 kΩ, Is=2.5 mA	IIP3		-10		dBm

Notes : 1) Power amplifier shall be unconditional stable, maximum duty cycle 100%, true cw-operation, maximum load mismatch 10:1 for 5 s @ 3.6 V

## Typical Characteristics

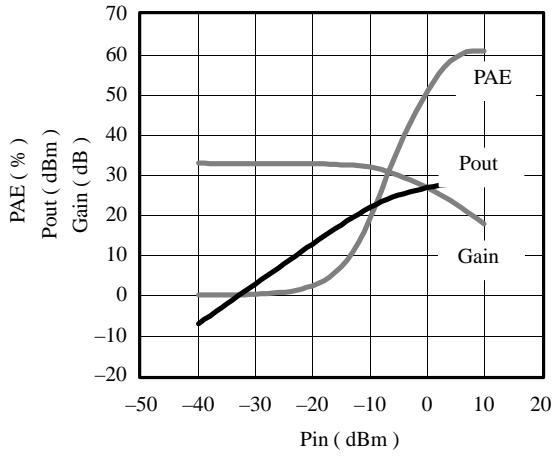

Figure 3. Power sweep

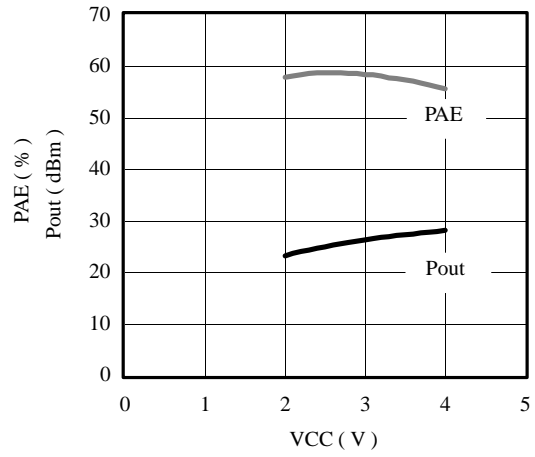

Figure 5. VCC sweep

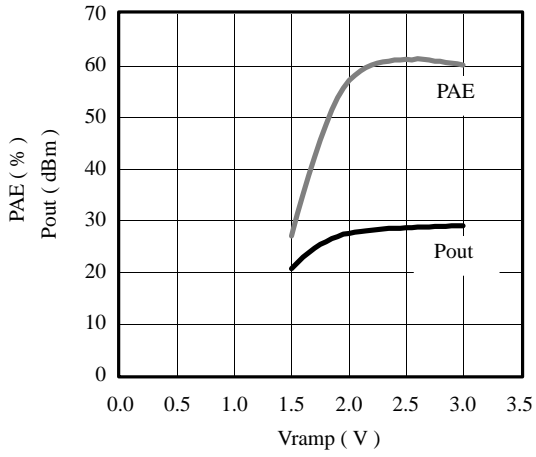

Figure 4. Ramp sweep

**Application Circuit T0980 (460 MHz)**

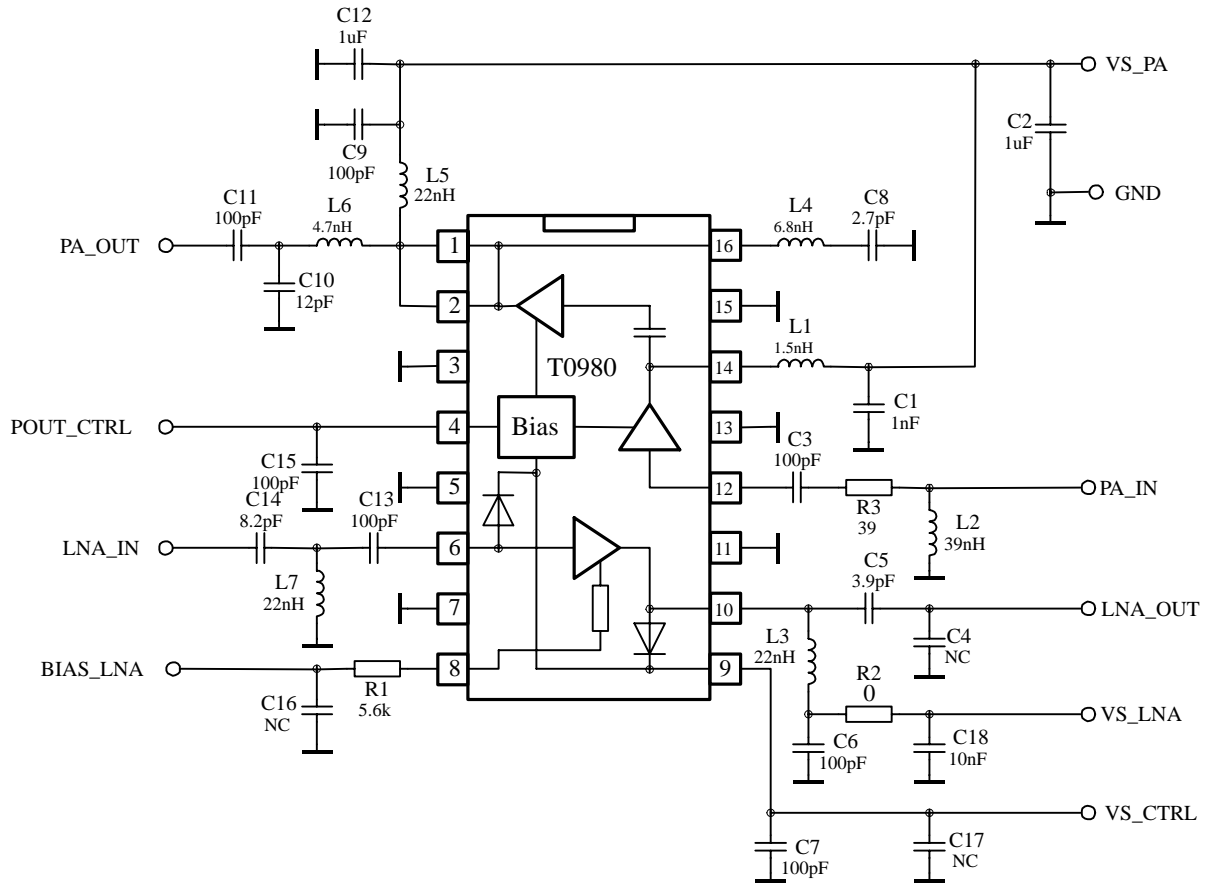
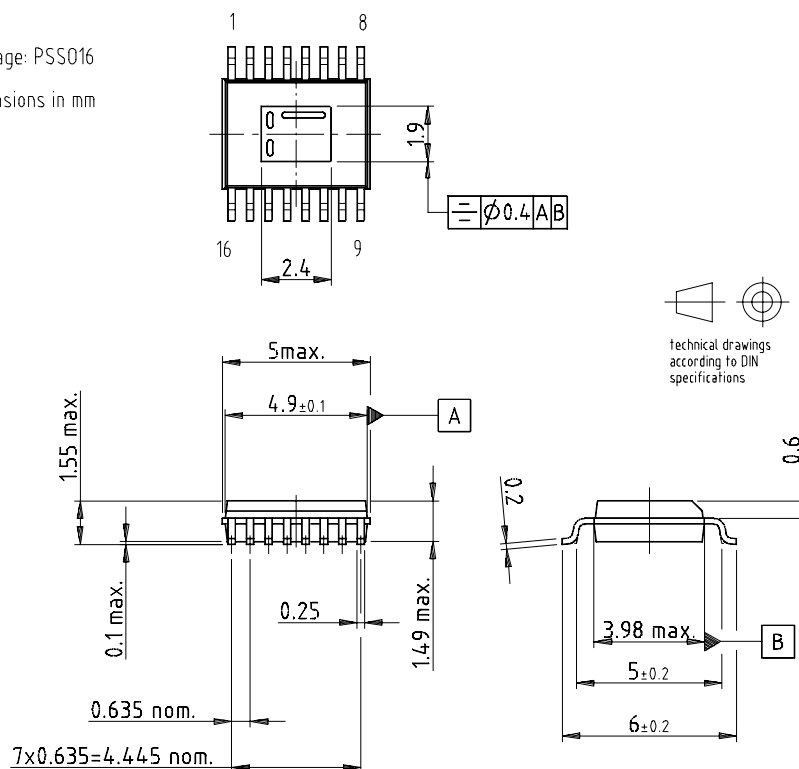

Figure 6. Typical application circuit T0980 (460 MHz)

## Package Information

Package: PSS016

Dimensions in mm



## Ozone Depleting Substances Policy Statement

It is the policy of **Atmel Germany GmbH** to

1. Meet all present and future national and international statutory requirements.
2. Regularly and continuously improve the performance of our products, processes, distribution and operating systems with respect to their impact on the health and safety of our employees and the public, as well as their impact on the environment.

It is particular concern to control or eliminate releases of those substances into the atmosphere which are known as ozone depleting substances (ODSs).

The Montreal Protocol (1987) and its London Amendments (1990) intend to severely restrict the use of ODSs and forbid their use within the next ten years. Various national and international initiatives are pressing for an earlier ban on these substances.

**Atmel Germany GmbH** has been able to use its policy of continuous improvements to eliminate the use of ODSs listed in the following documents.

1. Annex A, B and list of transitional substances of the Montreal Protocol and the London Amendments respectively
2. Class I and II ozone depleting substances in the Clean Air Act Amendments of 1990 by the Environmental Protection Agency (EPA) in the USA
3. Council Decision 88/540/EEC and 91/690/EEC Annex A, B and C (transitional substances) respectively.

**Atmel Germany GmbH** can certify that our semiconductors are not manufactured with ozone depleting substances and do not contain such substances.

**We reserve the right to make changes to improve technical design and may do so without further notice.**

Parameters can vary in different applications. All operating parameters must be validated for each customer application by the customer. Should the buyer use Atmel Wireless & Microcontrollers products for any unintended or unauthorized application, the buyer shall indemnify Atmel Wireless & Microcontrollers against all claims, costs, damages, and expenses, arising out of, directly or indirectly, any claim of personal damage, injury or death associated with such unintended or unauthorized use.

**Data sheets can also be retrieved from the Internet: <http://www.atmel-wm.com>**

Atmel Germany GmbH, P.O.B. 3535, D-74025 Heilbronn, Germany  
Telephone: 49 (0)7131 67 2594, Fax number: 49 (0)7131 67 2423