

Recording Equalizer Amplifier for Stereo Cassette Decks

Description

The CXA1597M/P is a bipolar IC developed for recording equalizer amplifier in analog cassette decks. It is suited specifically for double cassette decks. Incorporating the filter circuit greatly reduces the external parts.

Features

- Built-in filter required for recording equalizer amplifiers
- Inductor (coil) is unnecessary
- Low frequency boost is possible with an external capacitor
- Built-in recording mute function (requiring only an external time constant circuit to implement soft mute)
- Fade in/out DC controllable
- NORM/CrO₂/METAL tape mode switching function
- NORM/HIGH tape speed recording switching function
- DC controllable for recording level calibration (approximately ±6dB variable)
- DC controllable for high frequency equalizer amplifier gain (approximately ±4dB variable)
- Built-in 2 channels
- Small package

Applications

Recording equalizer amplifier for stereo analog cassette decks (Supports ALPS ELECTRIC CO., LTD. HADKH55-series heads)

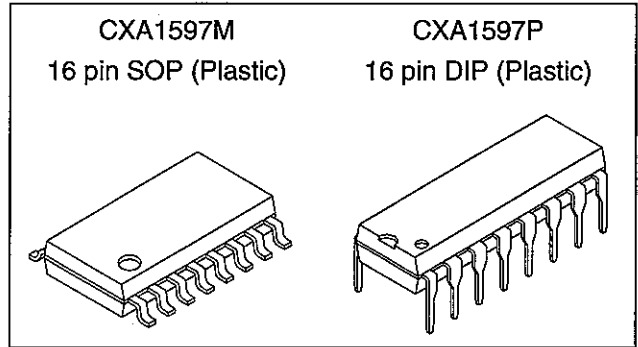

Structure

Bipolar silicon monolithic IC

Absolute Maximum Ratings

- Supply voltage V_{CC} 17 V
- Operating temperature T_{opr} -20 to +75 °C
- Storage temperature T_{stg} -65 to +150 °C
- Allowable power dissipation
 - P_D (CXA1597M) 500 mW
 - (CXA1597P) 900 mW

Operating Conditions

- Supply voltage Dual power supplies (V_{CC} - V_{EE}) ±5.0 to 8.0 V
- Single power supply (V_{CC}) 10.0 to 16.0 V

Block Diagram and Pin Configuration

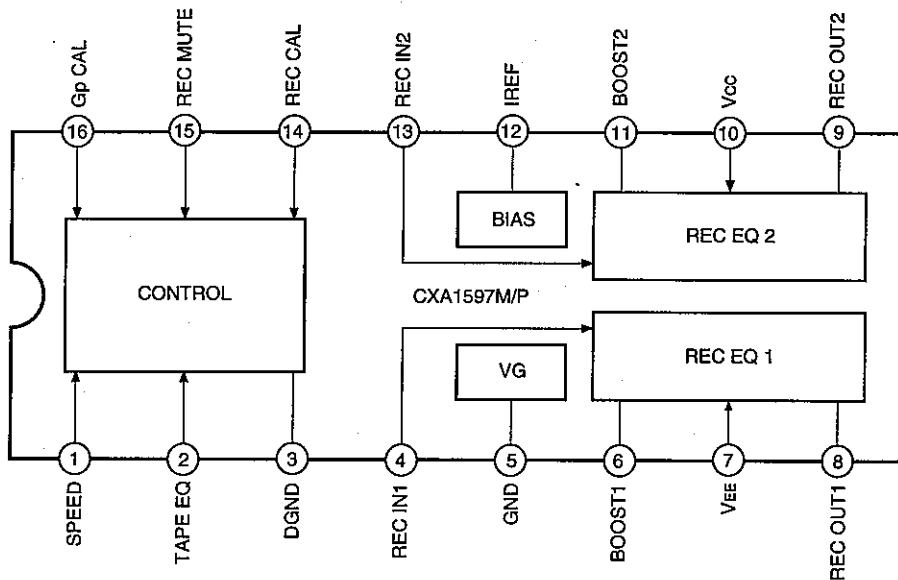

Sony reserves the right to change products and specifications without prior notice. This information does not convey any license by any implication or otherwise under any patents or other right. Application circuits shown, if any, are typical examples illustrating the operation of the devices. Sony cannot assume responsibility for any problems arising out of the use of these circuits.

Pin Description

(Ta = 25°C, Vcc = 7.0V, VEE = -7.0V, DVcc = 5.0V)

Pin No.	Symbol	Typical pin voltage		I/O	Z (in)	Equivalent circuit	Description
		DC	AC				
1	SPEED	—	—	I	—		Tape speed switching pin. * Normal/Double speed switching. High = Double speed Low = Normal speed
2	TAPE EQ	2.5V	—	I	—		Tape equalizer amplifier switching * (NORM/CrO ₂ /METAL switching) pin. High = REC EQ METAL Medium = REC EQ CrO ₂ Low = REC EQ NORM
3	DGND	0.0V	—	I	—		Connect to GND.
4 13	REC IN1 REC IN2	0.0V	-18dBv	I	50kΩ		Recording equalizer amplifier input pin.
5	GND (VG)	0.0V	—	I	15kΩ		Connect to GND for positive/negative dual power supplies. Vcc/2 (center potential) for a single power supply. (Connect a capacitor of 10μF or more)

Pin No.	Symbol	Typical pin voltage		I/O	Z (in)	Equivalent circuit	Description
		DC	AC				
6 11	BOOST1 BOOST2	0.0V	—	I	9.5kΩ		<p>Connection pin of an external capacitor for low frequency boost.</p> <p>* When low frequency boost is unnecessary, connect to GND for positive/negative dual power supplies; connect a capacitor (3.3μF or more) for a single power supply.</p>
7	V _{EE}	-7.0V	—	I	—		<p>Connect to the negative power supply for positive/negative dual power supplies. Connect to GND for a single power supply.</p>
8 9	REC OUT1 REC OUT2	0.0V	-3dBv	O	50kΩ		<p>Recording equalizer amplifier output pin.</p>
10	V _{CC}	7.0V	—	I	—		<p>Positive power supply connection pin.</p>
12	IREF	V _{EE} + 1.2V	—	O	—		<p>Reference current setting pin for monolithic filter.</p> <p>* The reference current can be set by attaching a resistor between this pin and the V_{EE} pin.</p>

Pin No.	Symbol	Typical pin voltage		I/O	Z (in)	Equivalent circuit	Description
		DC	AC				
14	REC CAL	2.5V	—	I	54k		<p>* Recording level calibration pin. High = Recording level gain increased Low = Recording level gain reduced * Leave this pin open when not using the recording level calibration function.</p>
15	REC MUTE	—	—	I	—		<p>Recording mute ON/OFF selection pin. * Recording mute is controlled with DC voltages of 0 to 5V. High = Recording mute OFF Low = Recording mute ON * Soft mute and fader can be switched over by changing the time constant of the external time constant circuit.</p>
16	Gp CAL	2.5V	—	I	54kΩ		<p>High frequency calibration pin. * Controlled with DC voltages of 0 to 5V High = High frequency level gain increased Low = High frequency level gain reduced * Leave this pin open when not using the high frequency calibration function.</p>

Electrical Characteristics

(Ta = 25°C, VCC = 7.0V, VEE = -7.0V)

Item		Conditions	Min.	Typ.	Max.	Unit
Entire LSI	Current consumption (Icc)		8.0	12.0	16.0	mA
	Operating voltage range 1 (positive/negative dual power supplies)		±5.0	±7.0	±8.0	V
	Operating voltage range 2 (single power supply)		10.0	14.0	16.0	V
Recording equalizer amplifier	Recording equalizer amplifier Recording reference output level NORM-NORM mode	Recording equalizer amplifier reference output level (315Hz) (This output level is the tape reference 0dB which generates magnetic flux of 250nWb/m) All of the recording equalizer amplifier blocks use this level as their reference level.		-3.0		dBV
	Recording equalizer amplifier Recording reference input level NORM-NORM mode	Input level when the reference output level is 315Hz, -3.0dBV (For measurement, input a 315Hz, -18.5dBV signal to the REC IN pins (Pins 4 and 13) and then measure the output level.)	-20.0	-18.5	-17.0	dBV
	NORM-NORM mode REC-EQ frequency response 1 (3kHz, -20dB)	NORM-tape, NORM-speed mode Input a 3kHz signal (-20dB level down) to the REC IN pins and then measure the relative deviation from NORM-NS, 315Hz mode.	-1.9	-0.4	1.1	dB
	NORM-NORM mode REC-EQ frequency response 2 (8kHz, -20dB)	NORM-tape, NORM-speed mode Input a 8kHz signal (-20dB level down) to the REC IN pins and then measure the relative deviation from NORM-NS, 315Hz mode.	2.5	4.5	6.5	dB
	NORM-NORM mode REC-EQ frequency response 3 (12kHz, -20dB)	NORM-tape, NORM-speed mode Input a 12kHz signal (-20dB level down) to the REC IN pins and then measure the relative deviation from NORM-NS, 315Hz mode.	7.3	10.3	13.3	dB
	CrO ₂ -NORM mode REC-EQ frequency response 1 (3kHz, -20dB)	CrO ₂ -tape, NORM-speed mode Input a 3kHz signal (-20dB level down) to the REC IN pins and then measure the relative deviation from NORM-NS, 315Hz mode.	2.9	4.4	5.9	dB
	CrO ₂ -NORM mode REC-EQ frequency response 2 (8kHz, -20dB)	CrO ₂ -tape, NORM-speed mode Input a 8kHz signal (-20dB level down) to the REC IN pins and then measure the relative deviation from NORM-NS, 315Hz mode.	7.1	9.1	11.1	dB
	CrO ₂ -NORM mode REC-EQ frequency response 3 (12kHz, -20dB)	CrO ₂ -tape, NORM-speed mode Input a 12kHz signal (-20dB level down) from the reference to the REC IN pins and then measure the relative deviation from NORM-NS, 315Hz mode.	11.3	14.3	17.3	dB
	METAL-NORM mode REC-EQ frequency response 1 (3kHz, -20dB)	METAL-tape, NORM-speed mode Input a 3kHz signal (-20dB level down) to the REC IN pins and then measure the relative deviation from NORM-NS, 315Hz mode.	3.9	5.4	6.9	dB
	METAL-NORM mode REC-EQ frequency response 2 (8kHz, -20dB)	METAL-tape, NORM-speed mode Input a 8kHz signal (-20dB level down) to the REC IN pins and then measure the relative deviation from NORM-NS, 315Hz mode.	7.1	9.1	11.1	dB

Item		Conditions	Min.	Typ.	Max.	Unit
Recording equalizer amplifier	METAL-NORM mode REC-EQ frequency response 3 (12kHz, -20dB)	METAL-tape, NORM-speed mode Input a 12kHz signal (-20dB level down) to the REC IN pins and then measure the relative deviation from NORM-NS, 315Hz mode.	10.4	13.4	16.4	dB
	NORM-HIGH mode REC-EQ frequency response 1 (5kHz, -20dB)	NORM-tape, HIGH-speed mode Input a 5kHz signal (-20dB level down) to the REC IN pins and then measure the relative deviation from NORM-NS, 315Hz mode.	-1.3	0.2	1.7	dB
	NORM-HIGH mode REC-EQ frequency response 2 (15kHz, -20dB)	NORM-tape, HIGH-speed mode Input a 15kHz signal (-20dB level down) to the REC IN pins and then measure the relative deviation from NORM-NS, 315Hz mode.	4.0	6.5	9.0	dB
	NORM-HIGH mode REC-EQ frequency response 3 (20kHz, -20dB)	NORM-tape, HIGH-speed mode Input a 20kHz signal (-20dB level down) to the REC IN pins and then measure the relative deviation from NORM-NS, 315Hz mode.	7.4	10.9	14.4	dB
	CrO ₂ -HIGH mode REC-EQ frequency response 1 (5kHz, -20dB)	CrO ₂ -tape, HIGH-speed mode Input a 5kHz signal (-20dB level down) to the REC IN pins and then measure the relative deviation from NORM-NS, 315Hz mode.	3.9	5.4	6.9	dB
	CrO ₂ -HIGH mode REC-EQ frequency response 2 (15kHz, -20dB)	CrO ₂ -tape, HIGH-speed mode Input a 15kHz signal (-20dB level down) to the REC IN pins and then measure the relative deviation from NORM-NS, 315Hz mode.	8.6	11.1	13.6	dB
	CrO ₂ -HIGH mode REC-EQ frequency response 3 (20kHz, -20dB)	CrO ₂ -tape, HIGH-speed mode Input a 20kHz signal (-20dB level down) to the REC IN pins and then measure the relative deviation from NORM-NS, 315Hz mode.	11.4	14.9	18.4	dB
	METAL-HIGH mode REC-EQ frequency response 1 (5kHz, -20dB)	METAL-tape, HIGH-speed mode Input a 5kHz signal (-20dB level down) to the REC IN pins and then measure the relative deviation from NORM-NS, 315Hz mode.	5.9	7.4	8.9	dB
	METAL-HIGH mode REC-EQ frequency response 2 (15kHz, -20dB)	METAL-tape, HIGH-speed mode Input a 15kHz signal (-20dB level down) to the REC IN pins and then measure the relative deviation from NORM-NS, 315Hz mode.	9.5	12.0	14.5	dB
	METAL-HIGH mode REC-EQ frequency response 3 (20kHz, -20dB)	METAL-tape, HIGH-speed mode Input a 20kHz signal (-20dB level down) to the REC IN pins and then measure the relative deviation from NORM-NS, 315Hz mode.	11.8	15.3	18.8	dB
	NORM-NORM mode REC-EQ signal handling	NORM-tape, NORM-speed mode, RL = 2.7kΩ Input a 1kHz signal and set the output so that THD (total harmonic distortion) is 1%. (Measure the distortion of a +11dB level-up signal.)	11.0	12.0	—	dB
	NORM-NORM mode REC-EQ total harmonic distortion (1kHz, 0.0dB, RL = 2.7kΩ)	NORM-tape, NORM-speed mode, RL = 2.7kΩ Input a 1kHz, 0.0dB (reference input level) signal and measure the distortion. (Measure the distortion as THD + N.)	—	0.14	0.6	%

Item		Conditions	Min.	Typ.	Max.	Unit	
Recording equalizer amplifier	NORM-NORM mode REC-EQ S/N ratio 1 ("A"-WGT filter)	NORM-tape, NORM-speed mode, Rg = 5.1kΩ With no signal, measure the noise using the "A"- WGT filter. (The measured value is indicated as the relative value compared to the reference level.)	57	65	—	dB	
	NORM-NORM mode Output DC offset voltage (REC OUT pin)	NORM-tape, NORM-speed mode With no signal, measure the DC offset voltage of the REC OUT pin.	-500	0.0	500	mV	
	NORM-NORM mode REC-EQ mute characteristics 1 (REC-MUTE = 0.5V)	NORM-tape, NORM-speed mode, REC-MUTE = 0.5V Input a 1kHz signal (+12dB level up) and measure the attenuation when REC MUTE is on. (Use a 1kHz BPF.)	—	-91	-80	dB	
	NORM-NORM mode REC-EQ mute characteristics 2 (REC-MUTE = 2.5V)	NORM-tape, NORM-speed mode, REC-MUTE = 2.5V Input a 1kHz, 0.0dB (reference level) signal and measure the attenuation characteristics curve of the soft mute function. (when REC-MUTE = 2.5V)	-7.0	-5.5	-4.0	dB	
	NORM-NORM mode REC-EQ REC-CAL characteristics 1 (REC-CAL = 5.0V)	NORM-tape, NORM-speed mode, REC-CAL = 5.0V Input a 315Hz signal (-20dB level down) and measure the amount of change compared to when the REC-CAL function is at the standard setting.	4.1	6.1	8.1	dB	
	NORM-NORM mode REC-EQ REC-CAL characteristics 2 (REC-CAL = 0.0V)	NORM-tape, NORM-speed mode, REC-CAL = 0.0V Input a 315Hz signal (-20dB level down) and measure the amount of change compared to when the REC-CAL function is at the standard setting.	-8.9	-6.9	-4.9	dB	
	NORM-NORM mode REC-EQ Gp-CAL characteristics 1 (GP-CAL = 5.0V)	NORM-tape, NORM-speed mode, Gp-CAL = 5.0V Input a 8kHz signal (-20dB level down) and measure the amount of change compared to when the Gp-CAL function is at the standard setting.	3.9	5.9	7.9	dB	
	NORM-NORM mode REC-EQ Gp-CAL characteristics 2 (GP-CAL = 0.0V)	NORM-tape, NORM-speed mode, Gp-CAL = 0.0V Input a 8kHz signal (-20dB level down) and measure the amount of change compared to when the Gp-CAL function is at the standard setting.	-5.9	-3.9	-1.9	dB	
Control circuit	Ternary switching	Mode control Control circuit high level	TAPE EQ control pin voltage	4.2	—	Vcc	V
		Mode control Control circuit medium level	TAPE EQ control pin voltage	2.2	—	2.8	V
		Mode control Control circuit low level	TAPE EQ control pin voltage	0.0	—	0.5	V
	Binary switching	Mode control Control circuit high level	SPEED control pin voltage	3.5	—	Vcc	V
		Mode control Control circuit low level	SPEED control pin voltage	0.0	—	0.5	V

Electrical Characteristics Measurement Circuit

- 8 -

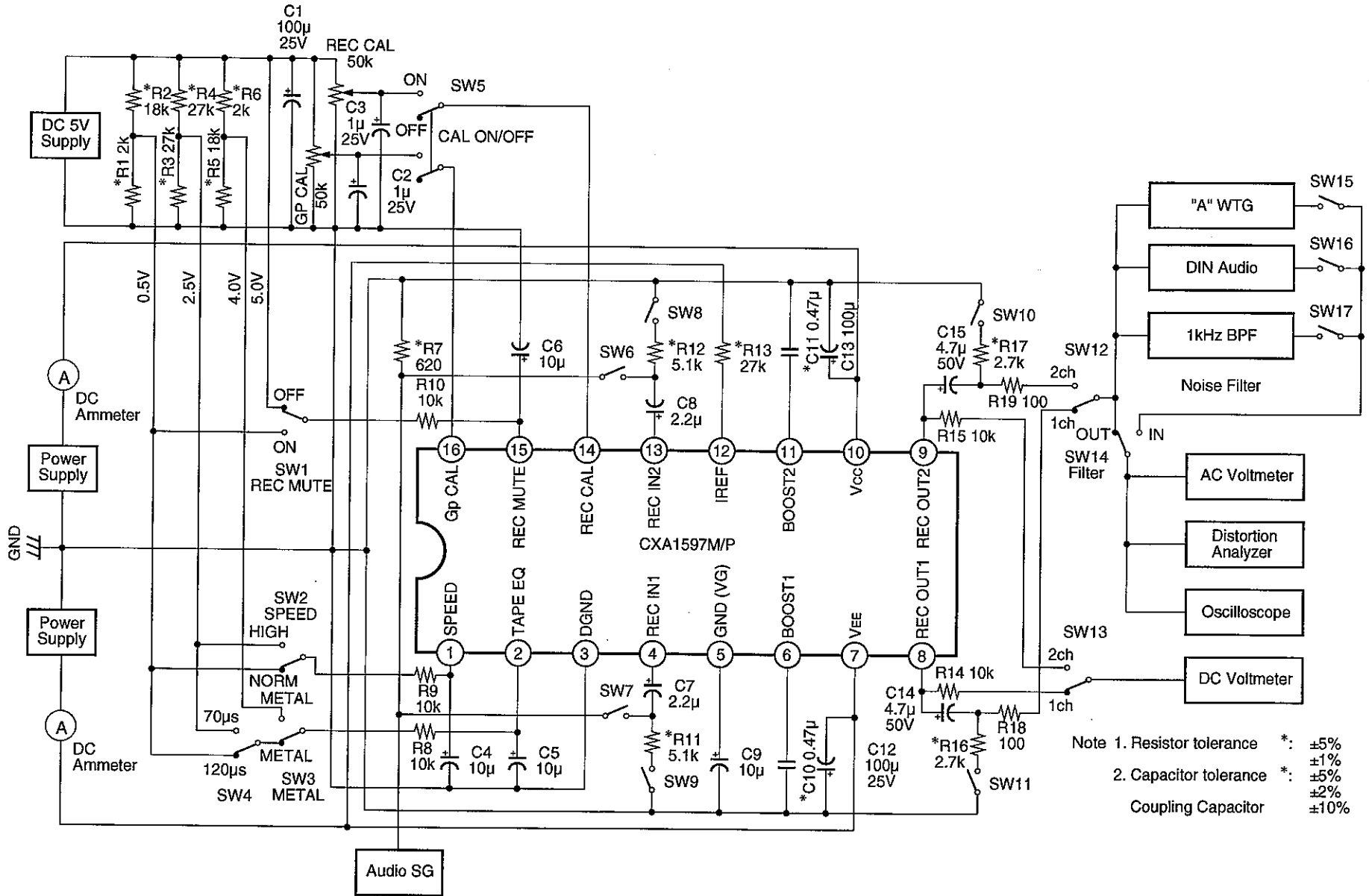

Application Circuit (Positive/Negative Dual Power Supplies)

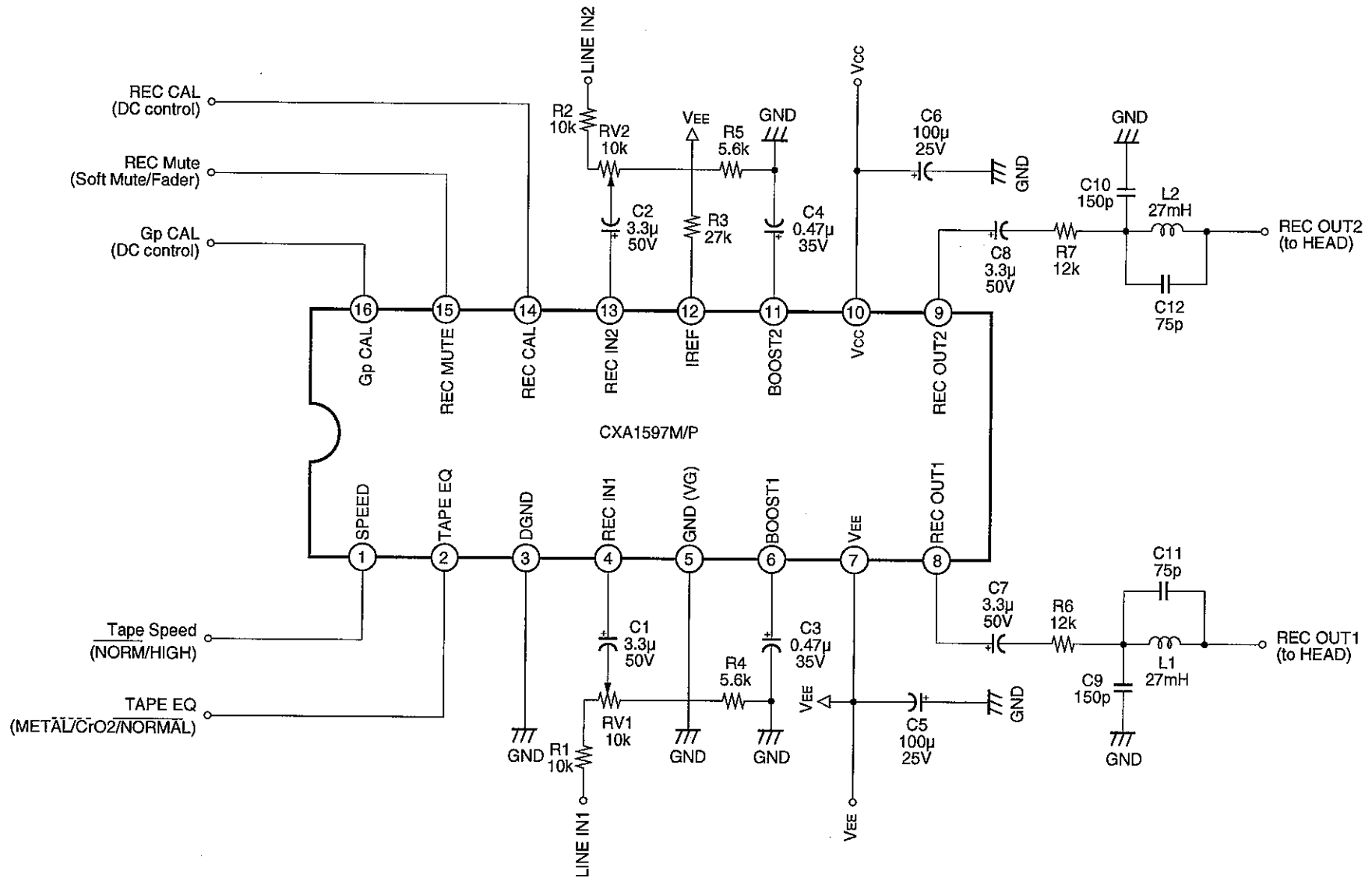

Application circuits shown are typical examples illustrating the operation of the devices. Sony cannot assume responsibility for any problems arising out of the use of these circuits or for any infringement of third party patent and other right due to same.

Description of Operation

1. Recording equalizer amplifier

The primary features of the CXA1597 recording equalizer amplifier are that by taking full advantage of monolithic filter technology, an LC resonance circuit consisting of a coil and capacitor normally required for high frequency compensation is dispensed with and medium and low-frequency sensitivity compensation is performed with its internal filter alone.

This IC has the circuit configuration shown in Fig. 1 to provide the optimum frequency response required for recording equalizer amplifiers.

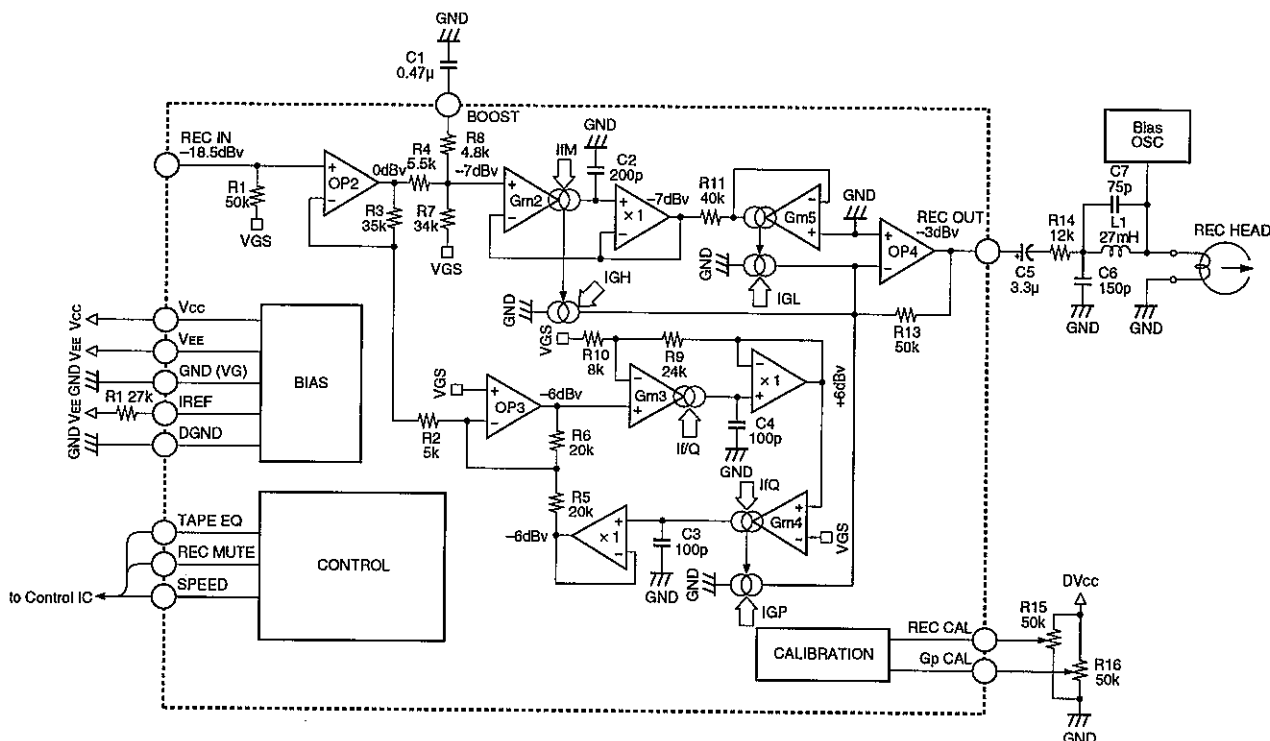

Fig. 1. CXA1597 functional circuit block diagram

The symbols (Gm2, Gm3, Gm4, Gm5) shown in Fig. 1 denote "voltage → current converter circuits" and "multiplier circuits."

The "voltage → current converter circuits" convert the voltage between the positive and negative input pins into current by using the IC's internal resistance. The "multiplier circuits" multiply the current generated by the "voltage → current converter circuits" with a coefficient.

The recording equalizer amplifier requires the six parameters shown in Fig. 2 (GL, GH, GP, fm, fp, and Q) to implement its frequency response. These parameters are controlled by each control current shown in Fig. 1 (IGL, IGH, IGP, IfM, If/Q, and IfQ).

Therefore, the CXA1597 reduces fluctuations caused by the temperature characteristics and unevenness of its internal resistance by using currents which are independent of the internal resistance (currents which depend on external resistance) and those which are dependent on the internal resistance.

This IC uses currents dependent on the internal resistance where equalizer amplifier gain is determined and currents dependent on external resistance where the filter time constant is determined. This is because the generatrix of the coefficient for the "multiplier circuits" is generated in the IC so that it depends on the internal resistance. Consequently, the gain relationship of GL, GH and GP is such that because the current obtained by the "voltage → current converter circuits" is converted into voltage by the I-V amplifier in the final stage of Fig. 1, the control currents are controlled by currents dependent on the internal resistance. In this way, the coefficients for conversion [voltage → current → voltage] all become ratios to the internal resistance, so that the fluctuations of temperature characteristics and unevenness are reduced.

Also, the relationship of time constants f_m , f_p and Q is configured by the product of the current obtained with the "voltage → current converter circuits" and the IC's internal capacitance connected to the output of each "multiplier circuit". By using the currents determined by the CXA1597 external resistance which are not dependent on the internal resistance for control, the coefficients for voltage → current conversion become certain ratios to the internal resistance; therefore, the frequency response does not depend on the internal resistance.

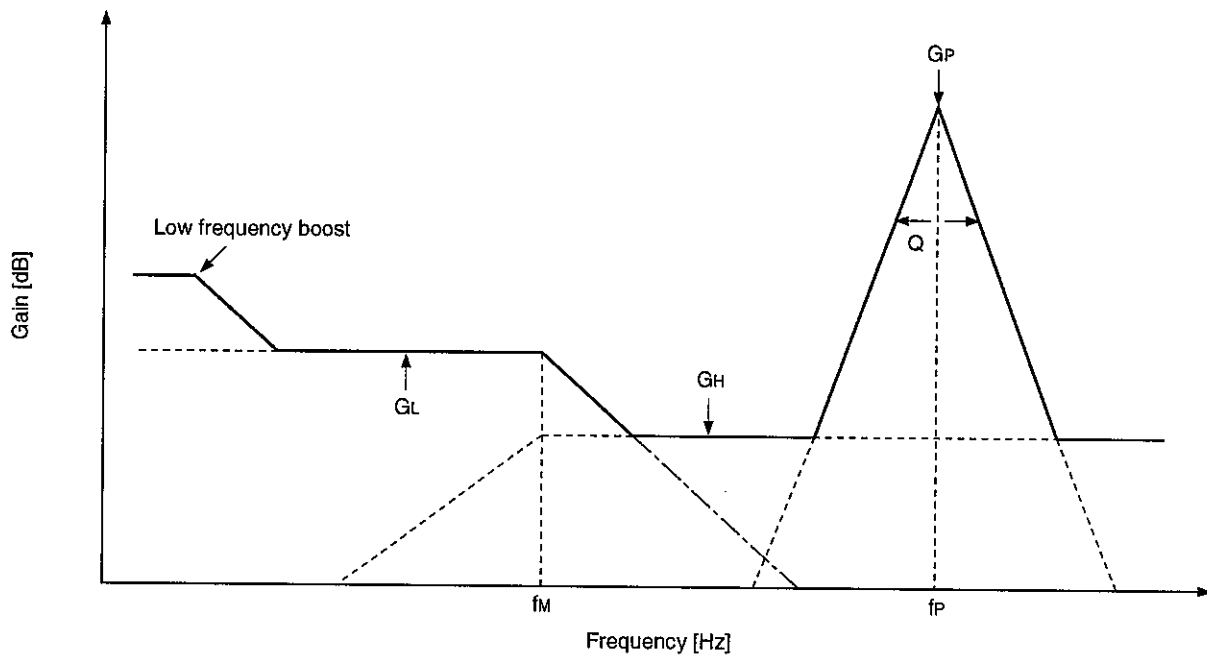

Fig. 2. Conceptual diagram of CXA1597 frequency response

2. Low frequency boost

The CXA1597 implements low frequency boost simply by attaching an external capacitor. As shown in Fig. 1, this IC contains a resistance-based attenuation circuit after the input amplifier, with one of the resistors connected to the BOOST pins (Pins 6 and 11). When a capacitor is connected to these BOOST pins (Pins 6 and 11), the following transfer function is obtained.

$$G_{BOOST}(s) = \frac{s \cdot C_1 \cdot R_7 \cdot R_8 + R_7}{s \cdot C_1 \cdot (R_4 \cdot R_7 + R_7 \cdot R_8 + R_8 \cdot R_4) + (R_4 + R_7)} \quad (s = j\omega)$$

From the above, items f_1 , f_2 , A_1 , and A_2 in Fig. 3 are transformed into the following:

$$f_1 = \frac{R_4 + R_7}{2\pi \cdot C_1 \cdot (R_4 \cdot R_7 + R_7 \cdot R_8 + R_8 \cdot R_4)} = \frac{1}{2\pi \cdot C_1 \cdot \left(\frac{R_4 \cdot R_7}{R_4 + R_7} + R_8 \right)}$$

$$f_2 = \frac{1}{2\pi \cdot C_1 \cdot R_8}$$

$$A_1 = \frac{R_7}{R_4 + R_7}$$

$$A_2 = \frac{R_7 \cdot R_8}{R_4 \cdot R_7 + R_7 \cdot R_8 + R_8 \cdot R_4} = \frac{\frac{R_7 \cdot R_8}{R_7 + R_8}}{R_4 + \frac{R_7 \cdot R_8}{R_7 + R_8}}$$

Here, $R_4 = 5.5k\Omega$, $R_7 = 34k\Omega$, and $R_8 = 4.8k\Omega$. Therefore, A_1 and A_2 take on the following values.

$A_1 = 0.861$ (times) = -1.30 (dB); $A_2 = 0.433$ (times) = -7.26 (dB)

The difference between A_1 and A_2 is approximately 6 dB, so that 6 dB boost can be applied for low frequency boost. The boost frequency response can be freely set with the value of the external C_1 capacitor.

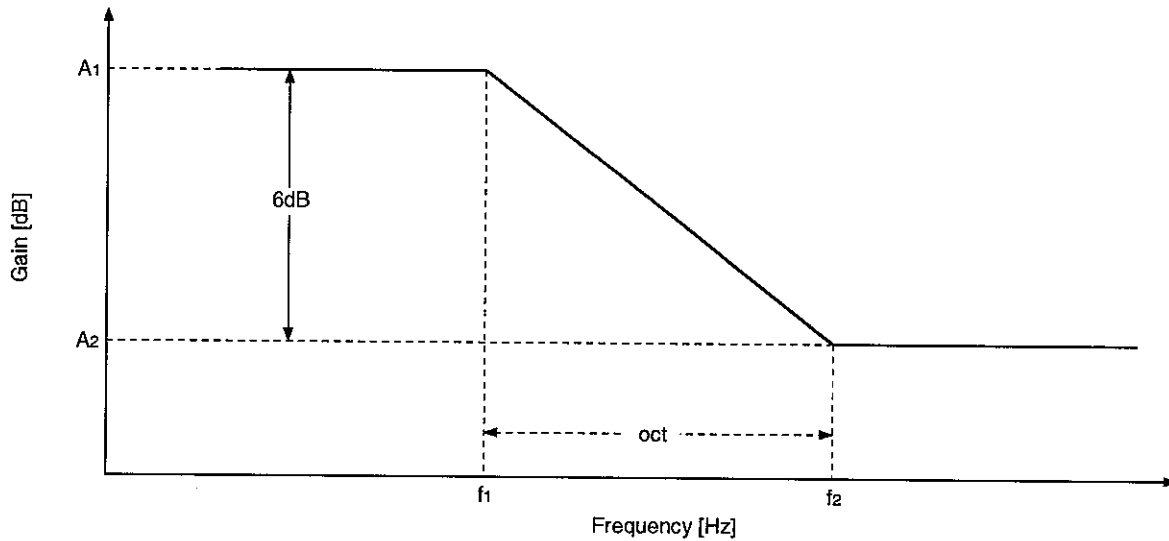

Fig. 3. CXA1597 low frequency boost frequency response

3. Recording mute function

The CXA1597 recording mute function is implemented by using a built-in recording mute circuit which varies the recording equalizer amplifier gain according to the magnitude of the DC voltage applied to the REC MUTE pin (Pin 15) just like an electronic volume control. For this reason, any desired soft mute (gradual signal attenuation without distortion) or fader (fade in/out) can be freely set depending on momentary changes in the DC voltage applied to the REC MUTE pin (Pin 15).

The CXA1597 recording mute circuit operation is such that the reference voltage source used to generate the control currents (I_{GL} , I_{GH} , and I_{GP}) to control each gain (G_L , G_H , and G_P) shown in Fig. 1 is varied by the voltage input to the REC MUTE pin (Pin 15), so that the recording signal is attenuated while maintaining the respective gain ratios. Eventually, when the recording signal is completely muted, only the I-V amplifier in the final stage is connected to the output pin (REC OUT). Therefore, the noise of the monolithic filter consisting of each "voltage \rightarrow current converter circuit" and "multiplier circuit" is attenuated simultaneously with the recording signal. At this point in time, the I-V amplifier in the final stage is functioning almost as a buffer, providing a significant amount of mute. Fig. 4 illustrates the recording mute waveforms.

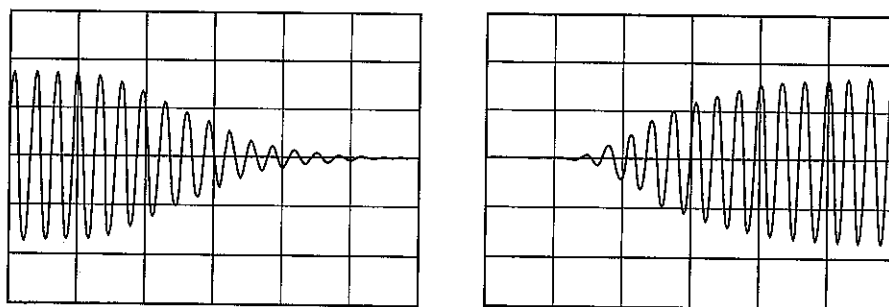

Fig. 4. Recording mute waveform

4. Recording level calibration function

The CXA1597 allows the recording level to be finely adjusted with a DC voltage. The recording equalizer amplifier gain can be varied by approximately $\pm 6\text{dB}$ simply by applying DC voltage to the REC CAL pin (Pin 14). Circuit operation for this function is such that each gain (G_L , G_H , and G_P) is varied relative to the reference voltage source which controls currents (I_{GL} , I_{GH} , and I_{GP}) by varying its voltage as in the case of the recording mute circuit.

The input resistance of the REC CAL pin (Pin 14) is $54\text{k}\Omega$ as described in the Pin Description, which is equivalent to the internal resistance. This means the voltage converted into current by the internal resistance is the difference between the DC voltage applied to the REC CAL pin (Pin 14) and the internal reference voltage (2.5V), so that all coefficients become ratios to the internal resistance. Recording level can be finely adjusted independent of the temperature characteristics and unevenness inherent in the IC.

This recording calibration function performs in all modes (NORM/CrO₂/Metal tape, NORM/HIGH speeds, as well as the recording mute mode).

When not using the recording level calibration function, simply leave the REC CAL pin (Pin 14) open, and the voltage on the REC CAL pin (Pin 14) is matched to the internal reference voltage (2.5V), with the recording level set for the standard output gain.

5. High frequency equalizer amplifier calibration function

In addition to the recording level calibration function, the CXA1597 allows high frequency equalizer amplifier characteristics to be controlled with DC voltage. By simply applying DC voltage to the G_P CAL pin (Pin 16) as in the case of the recording level calibration function, the recording equalizer amplifier gain (only the G_P gain) can be varied by approximately $\pm 4\text{dB}$. This function also relatively varies the G_P gain when the recording level calibration function is activated. Circuit operation for this function is such that the voltage applied to the pin is converted into current by the internal resistance as in the case of recording level calibration, and that the "multiplier circuits" provide a coefficient to the control current according to the value of the G_P gain control current (I_{GP}) for the mode currently set.

Therefore, the calibration of high frequency equalizer amplifier characteristics is independent of the temperature characteristics and unevenness inherent in the IC, as in the case of recording level calibration. This function, too, operates in all modes.

When not using the high frequency equalizer amplifier calibration function, simply leave the G_P CAL pin (Pin 16) open, and the high frequency equalizer amplifier characteristics are set for standard output gain.

Fig. 5 schematically shows the recording level/high frequency equalizer amplifier calibration functions.

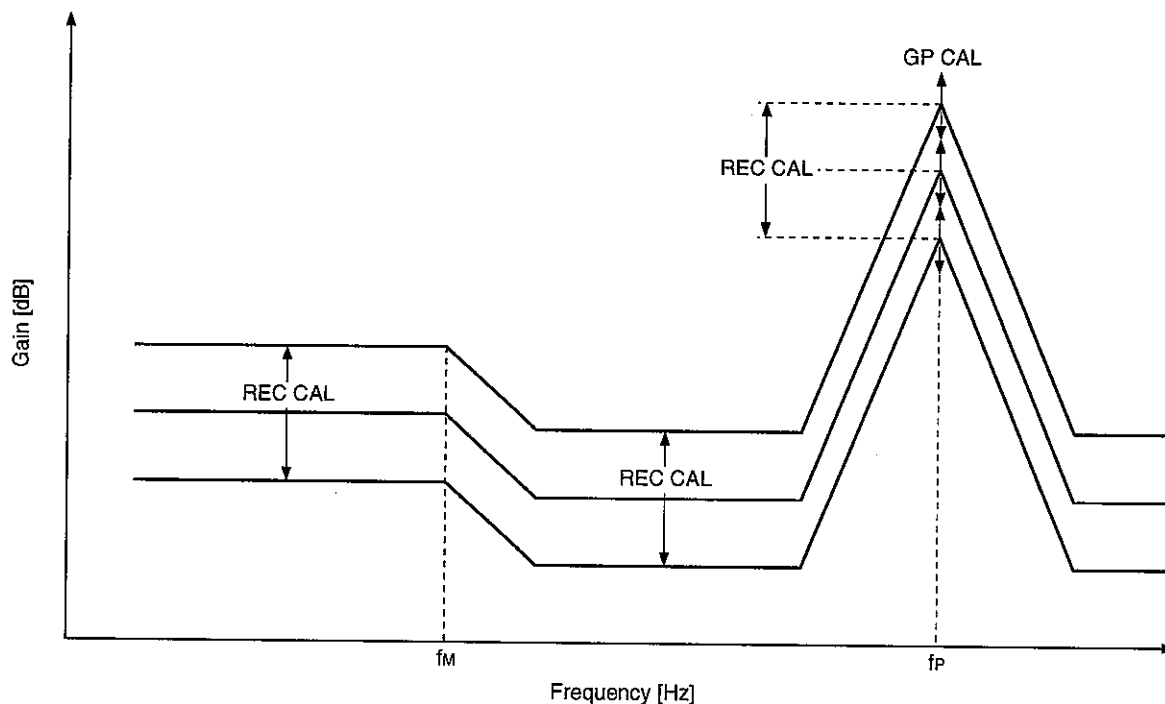

Fig. 5. Conceptual diagram of recording level/high frequency equalizer amplifier calibration functions

The noise level of the recording equalizer amplifier is relatively changed by varying its frequency characteristics.

6. Temperature characteristics and accuracy of the recording equalizer amplifier

The temperature characteristics of the built-in monolithic filter and the filter cut-off frequency depend on the 27k Ω external resistance connected to the IREF pin (Pin 12). For low frequency boost, however, the cut-off frequency becomes uneven depending on the temperature characteristics or unevenness of the internal resistance since its time constant is configured by the product of an external capacitor and the internal resistance.

Also, the recording equalizer frequency response depends on unevenness in the absolute, as well as relative values of the internal capacitance. Furthermore, the high frequency response indicates a high element sensitivity at the filter because the band-pass filter Q is high. Compared to low frequency, although the unevenness inherent in the IC is more likely to occur, this occurs relatively, and not individually for channels 1 and 2.

Notes on Operation

1. Power supply

The CXA1597 is designed basically for positive/negative dual power supplies, and can also operate with a single power supply. Connect the power supplies for each case as shown below:

	Vcc (Pin 10)	VEE (Pin 7)	GND (Pin 5)	DGND (Pin 3)
Positive/negative dual power supplies	Positive power supply	Negative power supply	GND	GND
Single power supply	Power supply	GND	*	GND

* For a single power supply, connect a decoupling capacitor (10μF or more) to the GND (VG) pin (Pin 5). The ripple rejection ratio depends on the capacitance of this capacitor.

2. Operation mode control (NORM/CrO₂/METAL tape, NORM/HIGH speed)

The CXA1597 incorporates an electronic switch and its operation is controlled by the DC voltage applied to the two mode control pins - TAPE EQ pin (Pin 3) and SPEED pin (Pin 1).

The mode control voltages are as follows

	Control voltage	Min.	Max.
3-state	High level	4.2	Vcc
	Medium level	2.2	2.8
	Low level	0.0	0.5
2-state	High level	3.5	Vcc
	Low level	0.0	0.5

The voltages in the table to the left are the values relative to DGND.

Operation mode control table

Pin No.	Pin name	Pin voltage			Remarks
		H	M	L	
1	SPEED	HIGH SPEED		NORMAL SPEED	2-state
2	TAPE EQ	METAL TAPE	CrO ₂ TAPE	NORMAL TAPE	3-state

Note: Pin voltage = Medium when the 3-state input pin is open.

If the switching click noise presents a problem, add time constant circuits of 0.1 to 1s to the mode control pins. Since the mode control circuit has a linear region of approximately ±300mV, this time constant circuit may effectively reduce the switching click noise.

3. Recording mute function (soft mute, fade in/out)

As described in Description of Operation, the CXA1597 recording mute function is implemented by using a built-in recording mute circuit which varies the recording equalizer amplifier gain according to the magnitude of the DC voltage applied to the REC MUTE pin (Pin 15) just like an electronic volume control. Consequently, the muting time can be varied according to momentary changes of the DC voltage applied to the REC MUTE pin (Pin 15) and, furthermore, the recording signal can be gradually attenuated without causing distortion. The table below shows the relationship between the DC voltage applied to the REC MUTE pin (Pin 15) and the attenuation.

Control voltage	Recording mute ON	Attenuation -6.6dB	Recording mute OFF
Positive/negative dual power supplies	DGND to 0.5V	2.5V	4.0V to Vcc
Single power supply	DGND to 0.5V	2.5V	4.0V to Vcc

* Referenced to the DGND pin (Pin 3).

4. Low frequency boost (low frequency compensation)

The CXA1597 low frequency boost function can be implemented simply by connecting a capacitor to the BOOST pins (Pins 6 and 11) as described in Description of Operation. Although the boost is fixed to 6dB, the time constant which determines the cut-off frequency can be set to any desired value depending on the capacitance of the external capacitor. The pole (f_1) and zero (f_2) shown in Fig. 3. Low frequency boost frequency response can be expressed, with the external capacitor assumed to be CB, as follows:

$$f_1 = \frac{1}{2\pi \cdot C_B \cdot (9.53k\Omega)} \text{ (Hz)}, f_2 = \frac{1}{2\pi \cdot C_B \cdot (4.8k\Omega)} \text{ (Hz)}$$

Based on the above equation, determine the best low frequency response.

However, the resistance which determines the time constant along with the external capacitor is the internal resistance, so that the cut-off frequency tends to fluctuate depending on the unevenness and temperature characteristics inherent in the IC. Note that the unevenness and the temperature characteristics of the internal resistance that determines the low frequency boost frequency response are approximately $\pm 20\%$ and $+2500 \text{ ppm}/^\circ\text{C}$, respectively.

When not using low frequency boost, follow the procedure described below.

a) For positive/negative dual power supplies

Connect the BOOST pins (Pins 6 and 11) to GND.

b) For single power supply

Connect a fairly large capacitor ($3.3\mu\text{F}$ or more) to the BOOST pins (Pins 6 and 11) or simply leave the BOOST pins open. If the BOOST pins are left open, note that the output level increases by 6dB, so the input reference should be set 6dB down. The CXA1597 is basically designed for positive/negative dual power supplies and the BOOST pins cannot be easily connected to GND as in the case of positive/negative dual power supplies.

5. Recording level calibration

The CXA1597 allows the recording level to be finely adjusted with a DC voltage as described in Description of Operation. Therefore, the recording level can be varied by approximately $\pm 6\text{dB}$ simply by applying DC voltages of 0 to 5V (for positive/negative dual power supplies) to the REC CAL pin (Pin 14).

The table below shows the input range regulation of control voltages with the power supplies used.*1, *2

	Up	Typ.	Down
Positive/negative dual power supplies	2.5V to Vcc	2.5V	DGND to 2.5V
Single power supply	2.5V to Vcc	2.5V	DGND to 2.5V

*1 Although the above range of voltages can be input to the control pin, the controllable input voltage range is as follows:

$$2.5\text{V} < V_{\text{up}} \leq 5.0\text{V}$$

$$\text{DGND} \leq V_{\text{down}} < 2.5\text{V}$$

*2 Control voltages for this IC are referenced to the DGND pin (Pin 3).

Also note that when not using this recording calibration function, simply leave the REC CAL pin (Pin 14) open, so that the voltage on the REC CAL pin is matched to the internal reference voltage (2.5V), with the recording level set for the standard gain.

6. High frequency calibration

The CXA1597 allows the high frequency equalizer amplifier characteristics to be finely adjusted with a DC voltage as described in Description of Operation. Therefore, the recording level in high frequencies (peak) can be varied by approximately $\pm 4\text{dB}$ simply by applying DC voltages of 0 to 5V (for positive/negative dual power supplies) to the G_P CAL pin (Pin 16).

The table below shows the input range regulation of control voltages with the power supplies used. *3, *4

	Up	Typ.	Down
Positive/negative dual power supplies	2.5V to Vcc	2.5V	DGND to 2.5V
Single power supply	2.5V to Vcc	2.5V	DGND to 2.5V

*3 Although the above range of voltages can be input to the control pin, the controllable input voltage range is as follows:

$$2.5\text{V} < V_{\text{up}} \leq 5.0\text{V}$$

$$\text{DGND} \leq V_{\text{down}} < 2.5\text{V}$$

*4 Control voltages for this IC are referenced to the DGND pin (Pin 3).

Also note that when not using this high frequency calibration function, simply leave the G_P CAL pin (Pin 16) open, so that the voltage on the G_P CAL pin is matched to the internal reference voltage (2.5V), with the high frequency equalizer amplifier characteristics set for the standard gain.

7. Monolithic filter (the resistance connected to the IREF pin)

To increase the accuracy of the frequency response of its internal monolithic filter, the CXA1597 entrusts the control current that determines the filter time constant to an external resistance. Specifically, this resistance is the 27k Ω external resistor connected to the IREF pin (Pin 12). This means that the accuracy of the recording equalizer amplifier frequency response is determined by the resistance connected to the IREF pin. Therefore, the resistor used for this purpose must be free of unevenness and have excellent temperature characteristics (e.g., a metallic film resistor).

Also note that the recording equalizer amplifier frequency response can be shifted as desired by altering the value of the resistance connected to the IREF pin. For example, when the resistance value is reduced, the frequency response is shifted to the high-frequency side, and when the resistance value is increased, the frequency response is shifted to the low-frequency side.

Example of Representative Characteristics

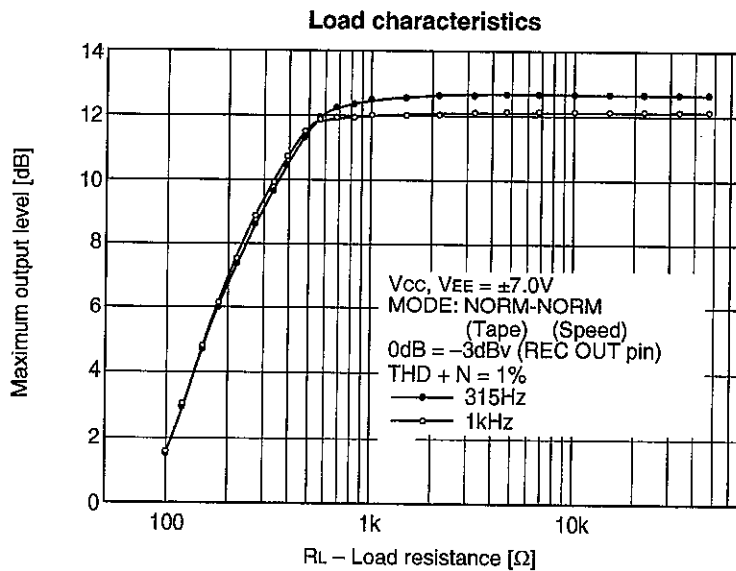
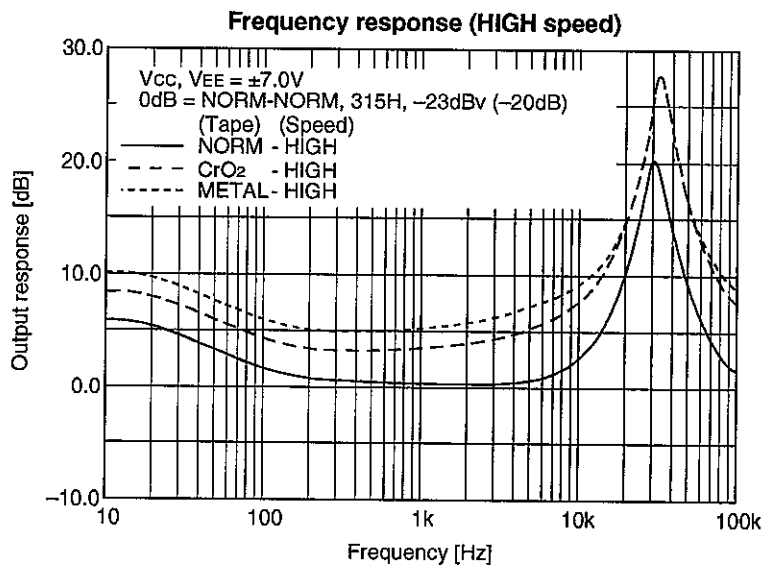
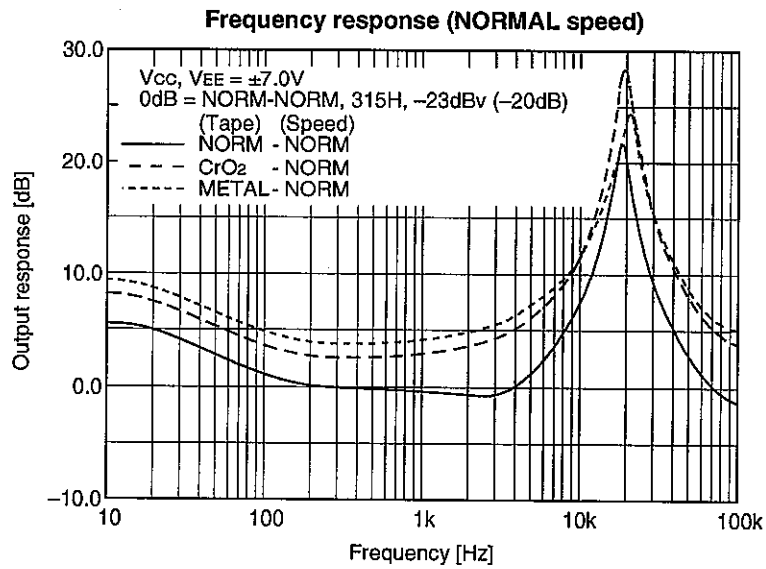

Total harmonic distortion

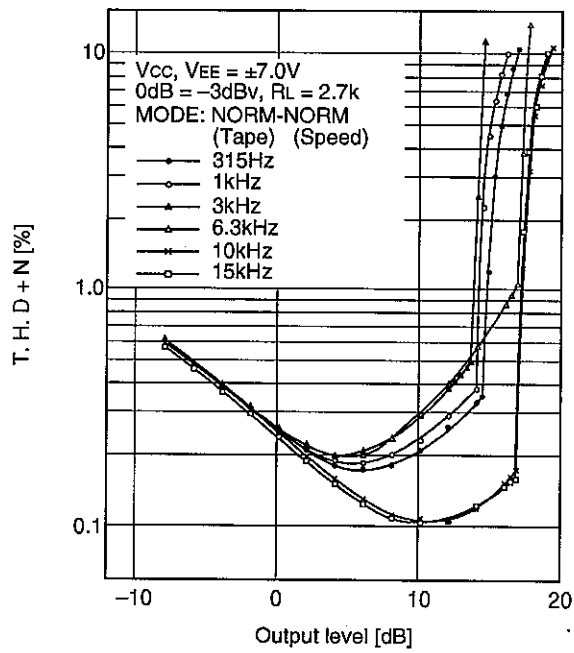

Output level vs. Mute voltage

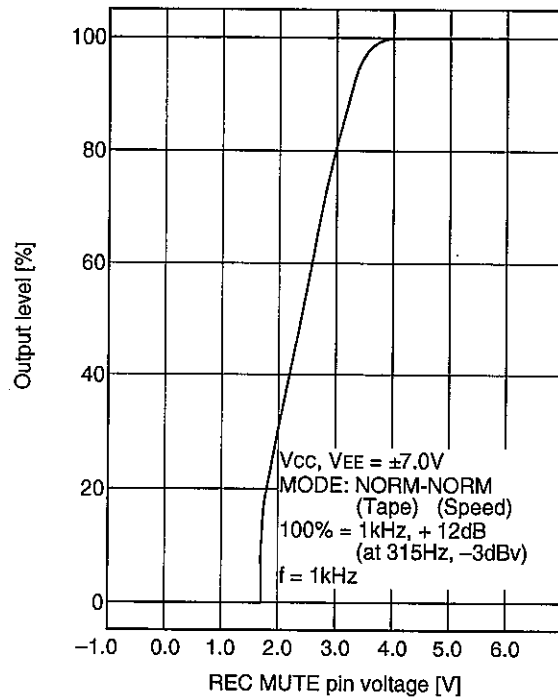

Output level vs. Mute voltage

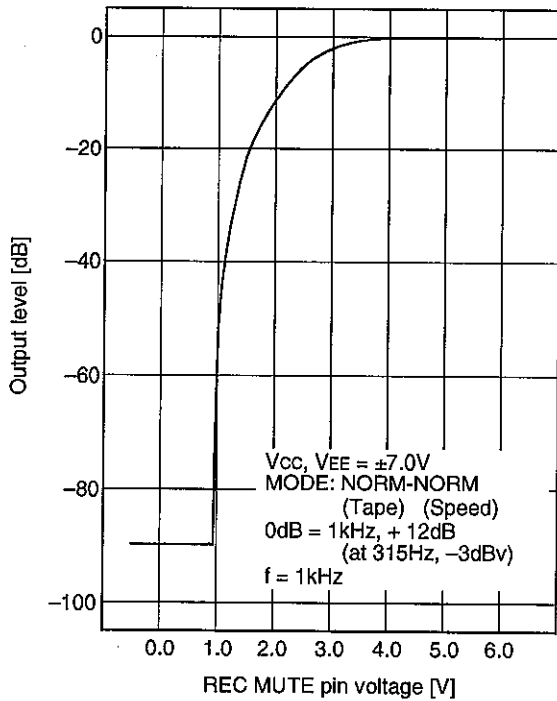

Output level vs. Mute voltage

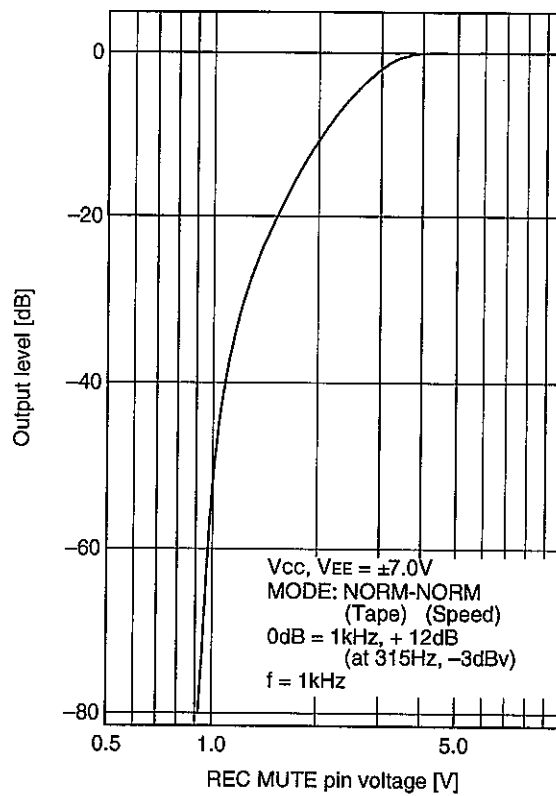

Output level vs. REC CAL voltage

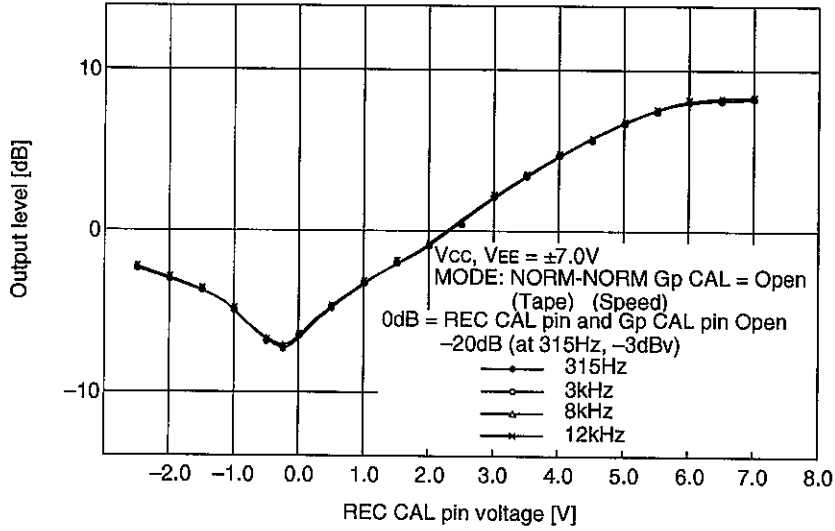

Output level vs. Gp CAL voltage

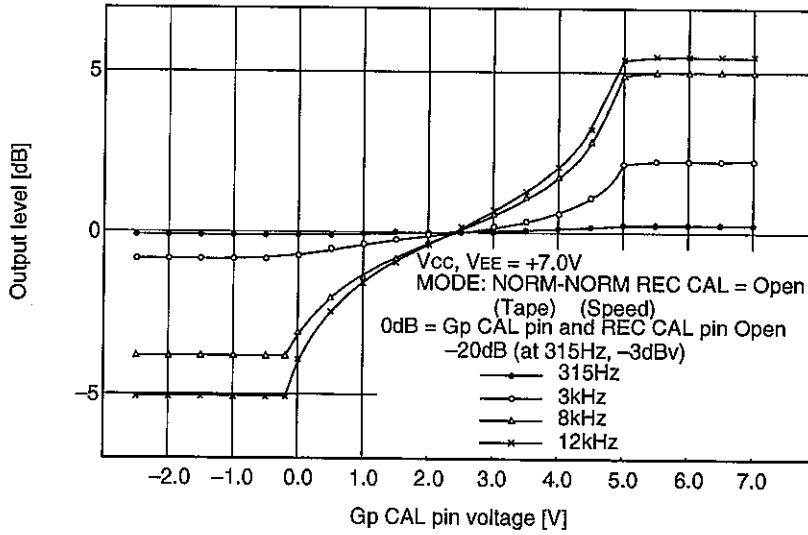

REC CAL and Gp CAL frequency response

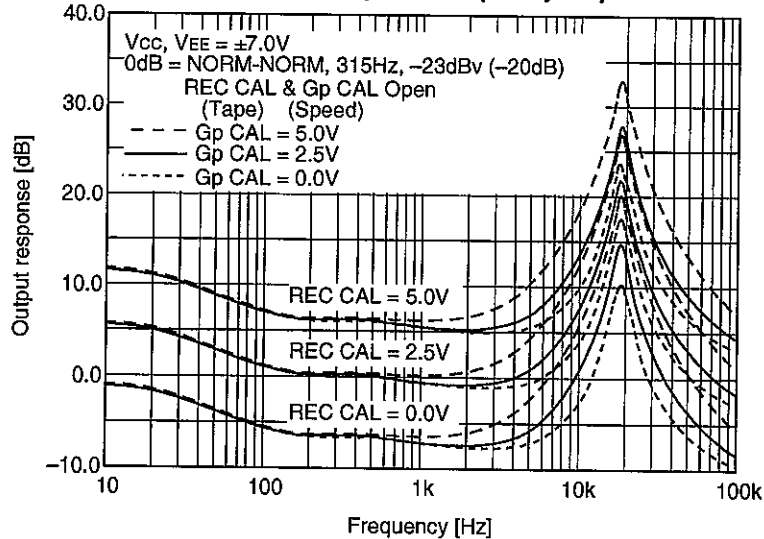

Supply voltage vs. Current consumption

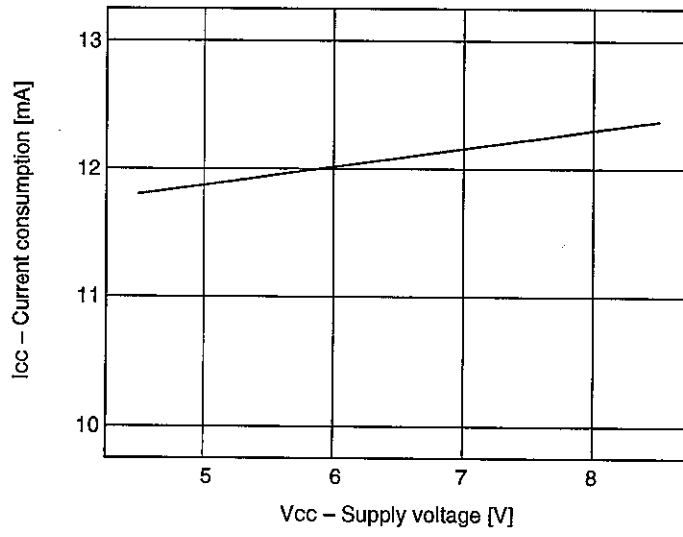

Package Outline

Unit: mm

CXA1597M

16PIN SOP (PLASTIC) 300mil

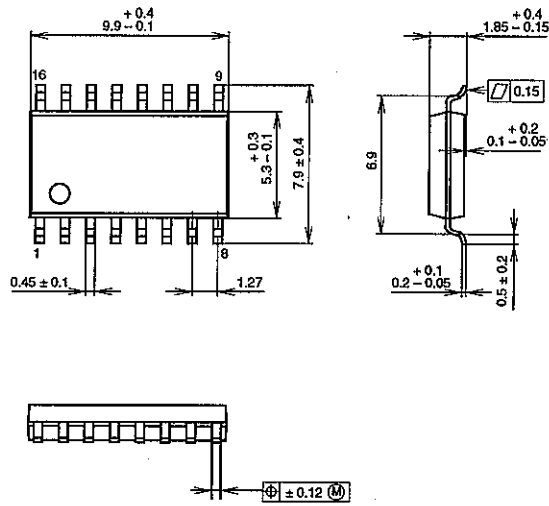

SONY CODE	SOP-16P-L01
EIAJ CODE	*SOP16-P-0300-A
JEDEC CODE	_____

PACKAGE STRUCTURE

PACKAGE MATERIAL	EPOXY RESIN
LEAD TREATMENT	SOLDER PLATING
LEAD MATERIAL	COPPER ALLOY
PACKAGE WEIGHT	0.2g

Package Outline

Unit: mm

16PIN DIP (PLASTIC)

CXA1597P

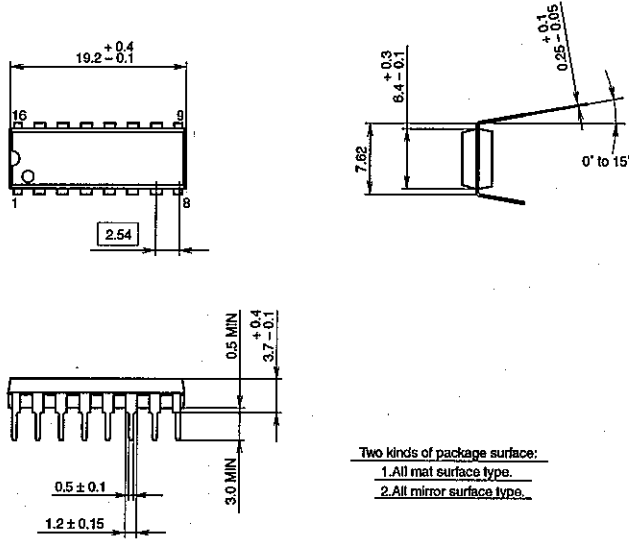

Two kinds of package surface:
 1. All mat surface type.
 2. All mirror surface type.

PACKAGE STRUCTURE

SONY CODE	DIP-16P-01
EIAJ CODE	DIP016-P-0900
JEDEC CODE	Similar to MO-001-AE

PACKAGE MATERIAL	EPOXY RESIN
LEAD TREATMENT	SOLDER PLATING
LEAD MATERIAL	COPPER ALLOY
PACKAGE MASS	1.0 g

16PIN DIP (PLASTIC)

CXA1597P

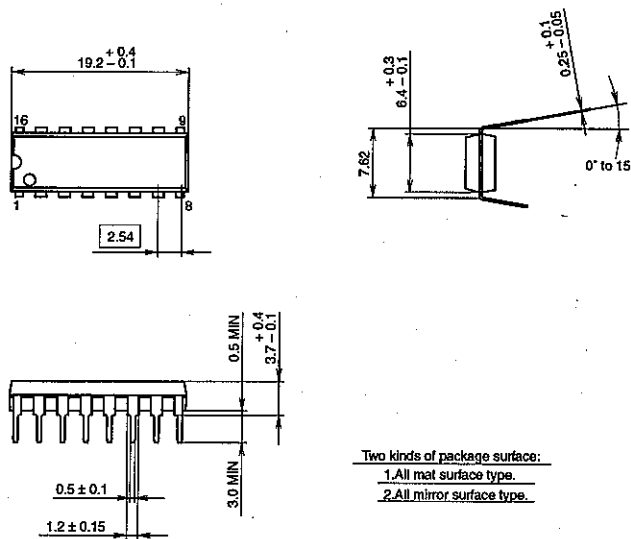

Two kinds of package surface:
 1. All mat surface type.
 2. All mirror surface type.

PACKAGE STRUCTURE

SONY CODE	DIP-16P-01
EIAJ CODE	DIP016-P-0900
JEDEC CODE	Similar to MO-001-AE

PACKAGE MATERIAL	EPOXY RESIN
LEAD TREATMENT	SOLDER PLATING
LEAD MATERIAL	COPPER ALLOY
PACKAGE MASS	1.0 g

LEAD PLATING SPECIFICATIONS

ITEM	SPEC.
LEAD MATERIAL	COPPER ALLOY
SOLDER COMPOSITION	Sn-Bi Bi:1-4wt%
PLATING THICKNESS	5-18µm