

8T13 Line Driver

Dual Line Driver
Product Specification

Logic Products

KEY DESIGN BENEFITS

- High-Power Drive Capability:
Specified at -75mA source current rating at 2.4 volts.
- Party-Line Operation:
Emitter-follower outputs enable two or more drivers to drive the same line. This permits multiple time-shared terminal connections since these drivers have no effect upon the transmission line unless activated.
- Input gating structure allows employment of the "OR" as well as the "AND" function.
- High Speed: Propagation Delay = 20ns (max).
- Input Clamp Diodes: Protects inputs from line ringing.
- Single 5 Volt power supply.
- Short Circuit Protection:
Incorporates a latch-back short circuit protection feature which protects the device by limiting the current it may source under conditions of zero load resistance.

TYPE	TYPICAL PROPAGATION DELAY	TYPICAL SUPPLY CURRENT (TOTAL)
8T13	32ns	

ORDERING CODE

PACKAGES	COMMERCIAL RANGE $V_{CC} = 5V \pm 5\%$; $T_A = 0^\circ\text{C}$ to $+70^\circ\text{C}$
Plastic DIP	N8T13N

NOTE:

For information regarding devices processed to Military Specifications, see the Signetics Military Products Data Manual.

INPUT AND OUTPUT LOADING AND FAN-OUT TABLE

PINS	DESCRIPTION	8T
All inputs	Input	1uI
7, 9	Output	46uI

NOTE:

A unit load (uI) is $40\mu\text{A } I_{IH}$ and $-1.6\text{mA } I_{IL}$.

DESCRIPTION

The 8T13 is a monolithic Dual Line Driver designed to drive 50Ω or 75Ω coaxial transmission lines. TTL multiple emitter inputs allow this line driver to interface with stand- and TTL or DTL

systems. The outputs are designed to drive long lengths of coaxial cable, strip line, or twisted pair transmission lines with impedances of 50Ω to 500Ω .

PIN CONFIGURATION

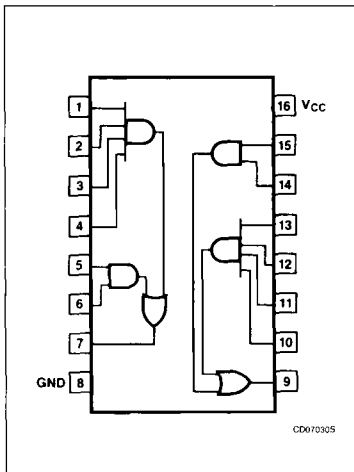

LOGIC SYMBOL

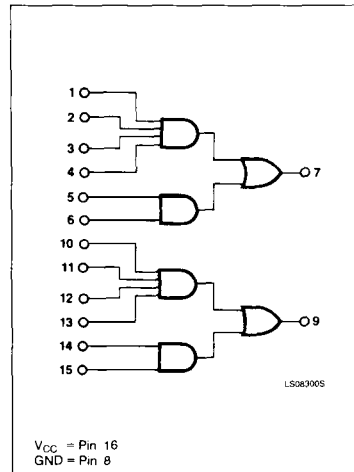

LOGIC SYMBOL (IEEE/IEC)

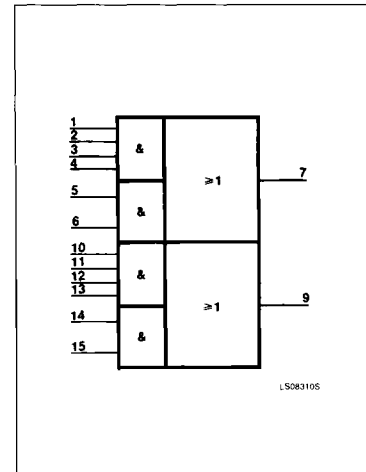

Line Driver

8T13

ABSOLUTE MAXIMUM RATINGS (Over operating free-air temperature range unless otherwise noted.)

PARAMETER		8T	UNIT
V _{CC}	Supply voltage	7.0	V
V _{IN}	Input voltage	-0.5 to +5.5	V
V _{OUT}	Voltage applied to output in HIGH output state	-0.5 to +V _{CC}	V
T _A	Operating free-air temperature range	0 to 70	°C

RECOMMENDED OPERATING CONDITIONS

PARAMETER		8T			UNIT
		Min	Nom	Max	
V _{CC}	Supply voltage	4.75	5.0	5.25	V
V _{IH}	HIGH-level input voltage	2.0			V
V _{IL}	LOW-level input voltage			0.8	V
I _{IK}	Input clamp current			-12	mA
I _{OH}	HIGH-level output current			75	mA
T _A	Operating free-air temperature	0		70	°C

DC ELECTRICAL CHARACTERISTICS (Over recommended operating free-air temperature range unless otherwise noted.)

PARAMETER		TEST CONDITIONS ¹	8T13		UNIT
			Min	Max	
V _{IH}	Input HIGH voltage	Guaranteed input HIGH threshold voltage	2.0		V
V _{IL}	Input LOW voltage	Guaranteed input LOW threshold voltage		0.8	V
V _{IK}	Input clamp diode voltage	V _{CC} = MIN, I _{IK} = -12mA		-1.5	V
V _{OH}	HIGH-level output voltage	V _{CC} = MIN, I _{OH} = 75mA	2.4		V
I _{IH}	HIGH-level input current	V _{CC} = MAX, V _I = 4.5V		40	μA
		V _{CC} = 0V, V _I = 4.5V			
I _{IL}	LOW-level input current	V _{CC} = MAX, V _{IN} = 0.4V		-1.6	mA
I _{OS}	Short-circuit output current ²	V _{CC} = MAX		-30	mA
I _{CC}	Supply current (total)	V _{CC} = 5.25V		60	mA

NOTES:

- For conditions shown as MIN or MAX, use the appropriate value specified under recommended operating conditions for the applicable type.
- I_{OS} is tested with V_{OUT} = +0.5V and V_{CC} = V_{CC} MAX + 0.5V. Not more than one output should be shorted at a time and duration of the short circuit should not exceed one second.

AC ELECTRICAL CHARACTERISTICS T_A = 25°C, V_{CC} = 5.0V

PARAMETER		TEST CONDITIONS	8T13		UNIT
			R _L = 37Ω		
			Min	Max	
t _{PLH}	Propagation delay	Waveform 1		20	ns
t _{PHL}				20	

Line Driver

8T13

AC TEST CIRCUIT AND WAVEFORM

