

# M5M27C102K-15I

1048576-BIT(65536-WORD BY 16-BIT)  
CMOS ERASABLE AND ELECTRICALLY REPROGRAMMABLE ROM

## DESCRIPTION

The Mitsubishi M5M27C102K-15I are high-speed 1048576-bit ultraviolet erasable and electrically reprogrammable read only memories. They are suitable for microprocessor programming applications where rapid turn-around is required. The M5M27C102K-15I are fabricated by N-channel double polysilicon gate for Memory and CMOS technology for peripheral circuits, and are available in DIP with a transparent lid.

## FEATURES

- Wide temperature range : - 40 °C ~ + 85 °C
- 65536 word × 16 bit organization
- Access time ..... 150ns (max.)
- Two line control  $\overline{OE}$ ,  $\overline{CE}$
- Low power current (I<sub>cc</sub>) : Active ..... 50mA (max.)  
Stand-by ..... 1mA (max.)
- Single 5V power supply (read operation)
- Programming voltage ..... 12.5V
- 3-State output buffer
- Input and output TTL-compatible in read and program mode
- Standard 40-pin DIP
- Word programming algorithm
- Page programming algorithm

## APPLICATION

Microcomputer systems and peripheral equipment

## FUNCTION

### Read

Set the  $\overline{CE}$  and  $\overline{OE}$  terminals to the read mode (low level). Low level input to  $\overline{CE}$  and  $\overline{OE}$  and address signals to the address inputs (A<sub>0</sub>~A<sub>15</sub>) make the data contents of the designated address location available at the data input/output (D<sub>0</sub>~D<sub>15</sub>). When the  $\overline{CE}$  or  $\overline{OE}$  signal is high, data input/output are in a floating state.

When the  $\overline{CE}$  signal is high, the device is in the standby mode or power-down mode.

### Programming

#### (Word programming algorithm)

The M5M27C102K-15I enter the byte programming mode when 12.5V is supplied to the V<sub>PP</sub> power supply input,  $\overline{CE}$  is at low level and  $\overline{OE}$  is at high level. A location is designated by address signals (A<sub>0</sub>~A<sub>15</sub>), and the data to be programmed must be applied at 16-bits in parallel to the data inputs (D<sub>0</sub>~D<sub>15</sub>). In this state, word programming is completed when PGM is at low level.

#### (Page programming algorithm)

Page programming feature of the M5M27C102K-15I allows 2 words of data to be simultaneously programmed. The destination addresses for a page programming operation must reside on the same page; that is, A<sub>1</sub> through A<sub>15</sub> must not change. At first, the M5M27C102K-15I enter the page data latch mode when V<sub>PP</sub> = 12.5V,  $\overline{CE}$  = "H",  $\overline{OE}$  = "L" and PGM = "H". A first and second locations in same page are designated by address signals (A<sub>0</sub>~A<sub>15</sub>), and the data to be

## PIN CONFIGURATION (TOP VIEW)

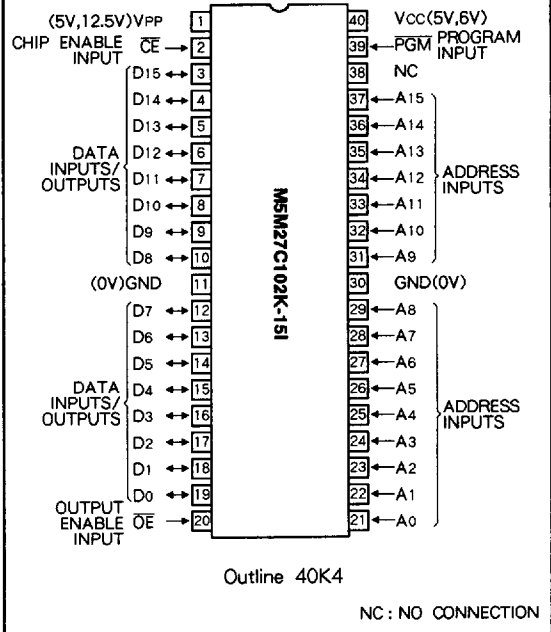

programmed must be applied to each location at 16-bits in parallel to the data inputs (D<sub>0</sub>~D<sub>15</sub>). In this state, the data (2 words) latch is completed. Then the M5M27C102K-15I enter the page programming mode when  $\overline{OE}$  = "H". In this state, page (2 words) programming is completed when PGM = "L".

**M5M27C102K-15I**

**1048576-BIT(65536-WORD BY 16-BIT)  
CMOS ERASABLE AND ELECTRICALLY REPROGRAMMABLE ROM**

**Erase**

Erase is effected by exposure to ultraviolet light with a wavelength of 2537Å at an intensity of approximately 15WS/cm<sup>2</sup>. Sunlight and fluorescent light may contain ultraviolet light sufficient to erase the programmed information. For any operation in the read mode, the transparent lid should be covered with opaque tape.

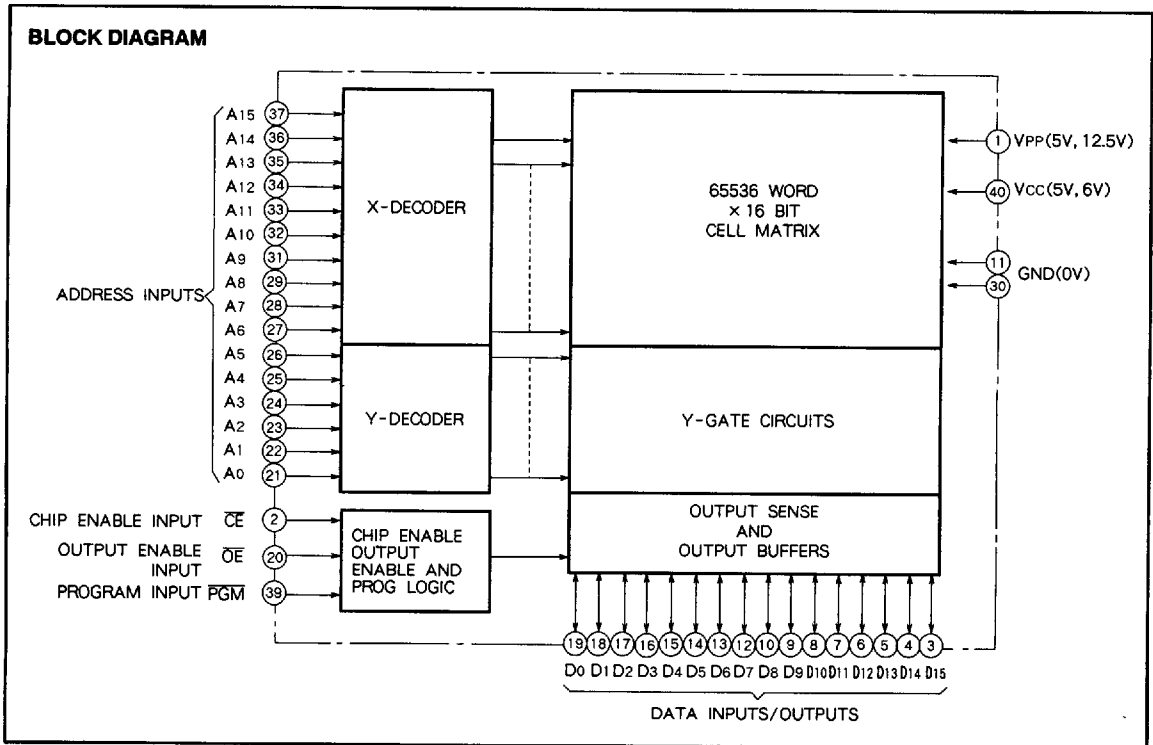

**MODE SELECTION**

Mode	Pins	CE (2)	OE (20)	PGM (39)	VPP (1)	VCC (40)	Data I/O (3~10, 12~19)
Read		V <sub>IL</sub>	V <sub>IL</sub>	X*	5V	5V	Data out
Output disable		V <sub>IL</sub>	V <sub>IH</sub>	X*	5V	5V	Floating
Standby (Power down)		V <sub>IH</sub>	X*	X*	5V	5V	Floating
Word program		V <sub>IL</sub>	V <sub>IH</sub>	V <sub>IL</sub>	12.5V	6V	Data in
Program verify		V <sub>IL</sub>	V <sub>IL</sub>	V <sub>IH</sub>	12.5V	6V	Data out
Page data latch		V <sub>IH</sub>	V <sub>IL</sub>	V <sub>IH</sub>	12.5V	6V	Data in
Page program		V <sub>IH</sub>	V <sub>IH</sub>	V <sub>IL</sub>	12.5V	6V	Floating
Program inhibit		V <sub>IL</sub>	V <sub>IL</sub>	V <sub>IL</sub>	12.5V	6V	Floating
		V <sub>IL</sub>	V <sub>IH</sub>	V <sub>IH</sub>	12.5V	6V	
		V <sub>IH</sub>	V <sub>IL</sub>	V <sub>IL</sub>	12.5V	6V	
		V <sub>IH</sub>	V <sub>IH</sub>	V <sub>IH</sub>	12.5V	6V	

\* : X can be either V<sub>IL</sub> or V<sub>IH</sub>

**M5M27C102K-15I**

**1048576-BIT(65536-WORD BY 16-BIT)  
CMOS ERASABLE AND ELECTRICALLY REPROGRAMMABLE ROM**

**ABSOLUTE MAXIMUM RATINGS** (Note 1)

Symbol	Parameter	Conditions	Ratings	Unit
V <sub>I1</sub>	All input or output voltage except V <sub>PP</sub> ·A <sub>9</sub>	With respect to Ground	-0.6~7	V
V <sub>I2</sub>	V <sub>PP</sub> supply voltage		-0.6~14.0	V
V <sub>I3</sub>	A <sub>9</sub> supply voltage		-0.6~13.5	V
T <sub>opr</sub>	Operating temperature		-50~95	°C
T <sub>stg</sub>	Storage temperature		-65~125	°C

Note 1: Stresses above those listed may cause permanent damage to the device. This is a stress rating only and functional operation of the device at those or at any other conditions above those indicated in the operational sections of this specification is not implied. Exposure to absolute maximum rating conditions for extended periods affects device reliability.

**READ OPERATION**

**DC ELECTRICAL CHARACTERISTICS** (T<sub>a</sub> = -40~85°C, V<sub>CC</sub> = 5V ± 10%, V<sub>PP</sub> = V<sub>CC</sub>, unless otherwise noted)

Symbol	Parameter	Test conditions	Limits			Unit
			Min	Typ	Max	
I <sub>LI</sub>	Input leakage current	V <sub>IN</sub> = 0~V <sub>CC</sub>			10	μA
I <sub>LO</sub>	Output leakage current	V <sub>OUT</sub> = 0~V <sub>CC</sub>			10	μA
I <sub>PP1</sub>	V <sub>PP</sub> current read/stand-by	V <sub>PP</sub> = 5.5V		1	100	μA
I <sub>SB1</sub>	V <sub>CC</sub> current stand-by	$\overline{CE} = V_{IH}$			1	mA
I <sub>SB2</sub>		$\overline{CE} = V_{CC}$		1	100	μA
I <sub>CC1</sub>	V <sub>CC</sub> current Active	$\overline{CE} = \overline{OE} = V_{IL}$ , DC, I <sub>OUT</sub> = 0mA			50	mA
I <sub>CC2</sub>		$\overline{CE} = V_{IL}$ , f = 6.7MHz, I <sub>OUT</sub> = 0mA			50	mA
V <sub>IL</sub>	Input low voltage		-0.1		0.8	V
V <sub>IH</sub>	Input high voltage		2.4		V <sub>CC</sub> + 1	V
V <sub>OL</sub>	Output low voltage	I <sub>OL</sub> = 2.1mA			0.45	V
V <sub>OH</sub>	Output high voltage	I <sub>OH</sub> = -400 μA	2.4			V

Note 2: Typical values are at T<sub>a</sub> = 25°C and nominal supply voltages.

**AC ELECTRICAL CHARACTERISTICS** (T<sub>a</sub> = -40~85°C, V<sub>CC</sub> = 5V ± 10%, V<sub>PP</sub> = V<sub>CC</sub>, unless otherwise noted)

Symbol	Parameter	Test conditions	Limits			Unit
			Min	Typ	Max	
t <sub>a(AD)</sub>	Address to output delay	$\overline{CE} = \overline{OE} = V_{IL}$			150	ns
t <sub>a(CE)</sub>	$\overline{CE}$ to output delay	$\overline{OE} = V_{IL}$			150	ns
t <sub>a(OE)</sub>	Output enable to output delay	$\overline{CE} = V_{IL}$			70	ns
t <sub>DF</sub>	Output enable high to output float	$\overline{CE} = V_{IL}$	0		50	ns
t <sub>OH</sub>	Output hold from $\overline{CE}$ , $\overline{OE}$ or address		0			ns

Note 3: V<sub>CC</sub> must be applied simultaneously V<sub>PP</sub> and removed simultaneously V<sub>PP</sub>.

**AC WAVEFORMS**

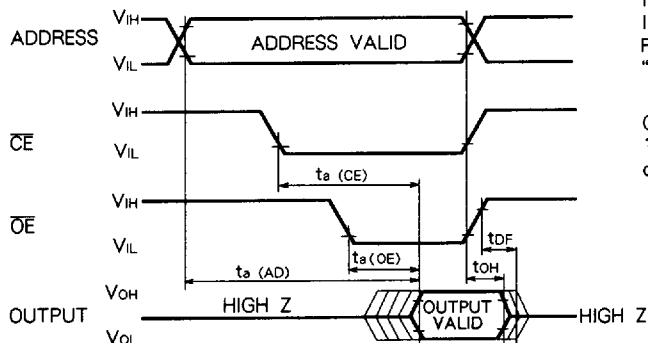

Test conditions for A.C. characteristics  
 Input voltage : V<sub>IL</sub> = 0.45V, V<sub>IH</sub> = 3.0V  
 Input rise and fall times : ≤ 20ns  
 Reference voltage at timing measurement : Input, Output  
 "L" = 0.8V, "H" = 2.4V

Output load :  
 1TTL gate + C<sub>L</sub> (= 100pF)  
 or

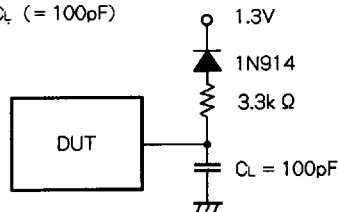

M5M27C102K-15I

1048576-BIT(65536-WORD BY 16-BIT)  
CMOS ERASABLE AND ELECTRICALLY REPROGRAMMABLE ROM

CAPACITANCE

Symbol	Parameter	Test conditions	Limits			Unit
			Min	Typ	Max	
C <sub>IN</sub>	Input capacitance (Address, $\overline{CE}$ , $\overline{OE}$ , PGM)	T <sub>a</sub> = 25 °C, f = 1MHz, V <sub>i</sub> = V <sub>o</sub> = 0V			15	pF
C <sub>OUT</sub>	Output capacitance				15	pF

PROGRAM OPERATION

WORD PROGRAMMING ALGORITHM

First set V<sub>CC</sub> = 6V, V<sub>PP</sub> = 12.5V and then set an address to first address to be programmed. After applying 0.2 ms program pulse (PGM) to the address, verify is performed. If the output data of that address is not verified correctly, apply one more 0.2 ms program pulse. The programmer continues 0.2 ms pulse-then-verify routines until the device verify correctly or twenty five of these pulse-then-verify routines have been completed. The programmer also maintains its total

number of 0.2 ms pulse applied to that address in register X. And then applied a program pulse X times of 0.2 ms width as an overprogram pulse. When the programming procedure above is finished, step to the next address and repeat this procedure till last address to be programmed. When the entire addresses have been programmed completely, all addresses should be verified with V<sub>CC</sub> = V<sub>PP</sub> = 5V.

DC ELECTRICAL CHARACTERISTICS (T<sub>a</sub> = 25 ± 5 °C, V<sub>CC</sub> = 6V ± 0.25V, V<sub>PP</sub> = 12.5V ± 0.3V, unless otherwise noted)

Symbol	Parameter	Test conditions	Limits			Unit
			Min	Typ	Max	
I <sub>LI</sub>	Input leakage current	V <sub>IN</sub> = 0~V <sub>CC</sub>			10	μ A
V <sub>OL</sub>	Output low voltage (verify)	I <sub>oL</sub> = 2.1mA			0.45	V
V <sub>OH</sub>	Output high voltage (verify)	I <sub>oH</sub> = -400 μ A				V
V <sub>IL</sub>	Input low voltage		-0.1		0.8	V
V <sub>IH</sub>	Input high voltage		2.0		V <sub>CC</sub>	V
I <sub>CC</sub>	V <sub>CC</sub> supply current				50	mA
I <sub>PP</sub>	V <sub>PP</sub> supply current	$\overline{CE}$ = PGM = V <sub>IL</sub>			50	mA

AC ELECTRICAL CHARACTERISTICS (T<sub>a</sub> = 25 ± 5 °C, V<sub>CC</sub> = 6V ± 0.25V, V<sub>PP</sub> = 12.5V ± 0.3V, unless otherwise noted)

Symbol	Parameter	Test conditions	Limits			Unit
			Min	Typ	Max	
t <sub>AS</sub>	Address setup time		2			μ s
t <sub>oES</sub>	$\overline{OE}$ setup time		2			μ s
t <sub>DS</sub>	Data setup time		2			μ s
t <sub>AH</sub>	Address hold time		0			μ s
t <sub>DH</sub>	Data hold time		2			μ s
t <sub>DFP</sub>	Chip enable to output float delay		0		130	ns
t <sub>VCS</sub>	V <sub>CC</sub> setup time		2			μ s
t <sub>VPS</sub>	V <sub>PP</sub> setup time		2			μ s
t <sub>PW</sub>	PGM initial program pulse width		0.19	0.2	0.21	ms
t <sub>OPW</sub>	PGM over program pulse width		0.19		5.25	ms
t <sub>CES</sub>	$\overline{CE}$ setup time		2			μ s
t <sub>oE</sub>	Data valid from $\overline{OE}$				150	ns

Note 4: V<sub>CC</sub> must be applied simultaneously V<sub>PP</sub> and removed simultaneously V<sub>PP</sub>.

1048576-BIT(65536-WORD BY 16-BIT)  
CMOS ERASABLE AND ELECTRICALLY REPROGRAMMABLE ROM

AC WAVEFORMS

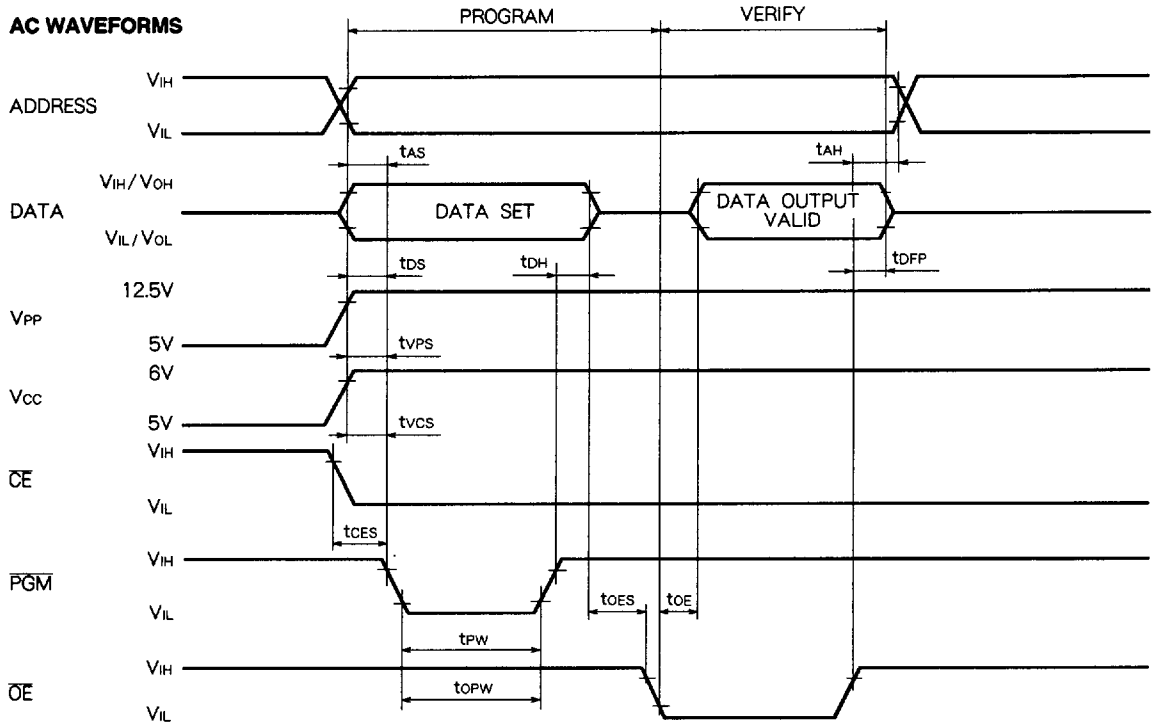

Test conditions for A.C. characteristics  
 Input voltage :  $V_{IL} = 0.45V, V_{IH} = 2.4V$   
 Input rise and fall times :  $\leq 20ns$   
 Reference voltage at timing measurement : Input, Output  
 "L" = 0.8V, "H" = 2V.

WORD PROGRAMMING ALGORITHM  
FLOW CHART

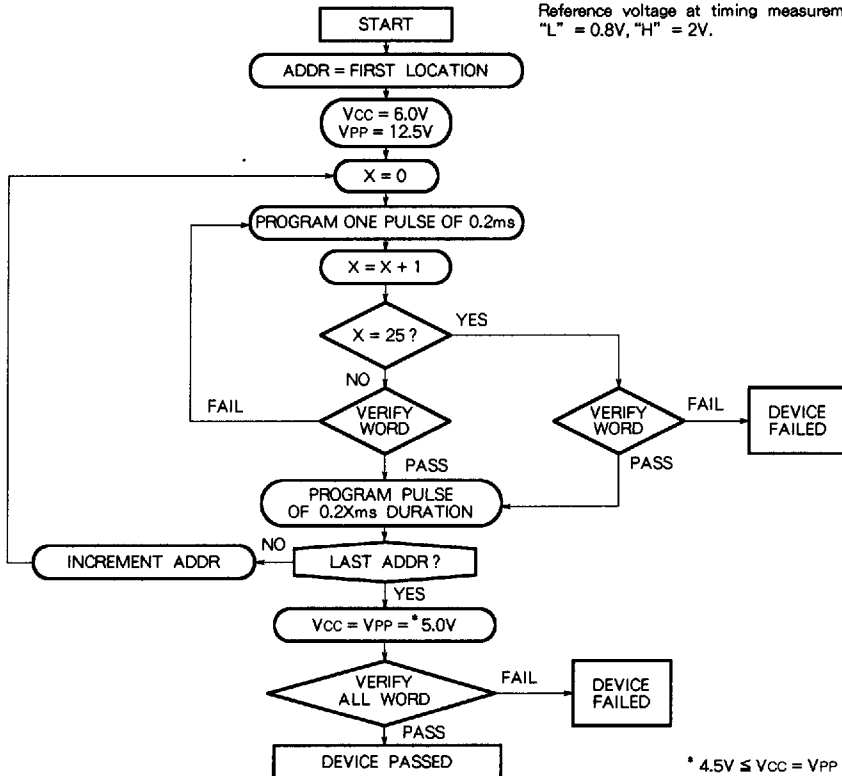

\* 4.5V  $\leq V_{CC} = V_{PP} \leq 5.5V$

## M5M27C102K-15I

1048576-BIT(65536-WORD BY 16-BIT)  
CMOS ERASABLE AND ELECTRICALLY REPROGRAMMABLE ROM

## PAGE PROGRAMMING ALGORITHM

First set  $V_{CC} = 6V$ ,  $V_{PP} = 12.5V$  and then set an address to first page address to be programmed. After data of 2 words are latched, these latch data are programmed simultaneously by applying 0.2 ms program pulse. Then a verify is performed. If each output data is not verified correctly, apply one more 0.2 ms program pulse. The programmer continues 0.2 ms pulse-then-verify routines until each output data is verified correctly or twenty five of these pulse-then-verify routines have been completed.

The programmer also maintains its total number of 0.2 ms pulse applied to that page addresses in register X. And then applied a program pulse X times of 0.2 ms width as an overprogram pulse. When the programming procedure above is finished, step to the next page address and repeat this procedure till last page address to be programmed. When the entire page addresses have been programmed completely, all addresses should be verified with  $V_{CC} = V_{PP} = 5V$ .

DC ELECTRICAL CHARACTERISTICS ( $T_a = 25 \pm 5^\circ C$ ,  $V_{CC} = 6V \pm 0.25V$ ,  $V_{PP} = 12.5V \pm 0.3V$ , unless otherwise noted)

Symbol	Parameter	Test conditions	Limits			Unit
			Min	Typ	Max	
$I_{LI}$	Input leakage current	$V_{IN} = 0 \sim V_{CC}$			10	$\mu A$
$V_{OL}$	Output low voltage (verify)	$I_{OL} = 2.1mA$			0.45	V
$V_{OH}$	Output high voltage (verify)	$I_{OH} = -400 \mu A$	2.4			V
$V_{IL}$	Input low voltage		-0.1		0.8	V
$V_{IH}$	Input high voltage		2.0		$V_{CC}$	V
$I_{CC}$	$V_{CC}$ supply current				50	mA
$I_{PP}$	$V_{PP}$ supply current	$PGM = V_{IL}$			100	mA

AC ELECTRICAL CHARACTERISTICS ( $T_a = 25 \pm 5^\circ C$ ,  $V_{CC} = 6V \pm 0.25V$ ,  $V_{PP} = 12.5V \pm 0.3V$ , unless otherwise noted)

Symbol	Parameter	Test conditions	Limits			Unit
			Min	Typ	Max	
$t_{AS}$	Address setup time		2			$\mu s$
$t_{OES}$	$\overline{OE}$ setup time		2			$\mu s$
$t_{DS}$	Data setup time		2			$\mu s$
$t_{AH}$	Address hold time		0			$\mu s$
$t_{AHL}$			2			$\mu s$
$t_{DH}$	Data hold time		2			$\mu s$
$t_{DFP}$	$\overline{OE}$ to output float delay		0		130	ns
$t_{VCS}$	$V_{CC}$ setup time		2			$\mu s$
$t_{VPS}$	$V_{PP}$ setup time		2			$\mu s$
$t_{PW}$	$\overline{PGM}$ initial program pulse width		0.19	0.2	0.21	ms
$t_{OPW}$	$\overline{PGM}$ over program pulse width		0.19		5.25	ms
$t_{CES}$	$\overline{CE}$ setup time		2			$\mu s$
$t_{OE}$	Data valid from $\overline{OE}$				150	ns
$t_{LW}$	Data latch time		1			$\mu s$
$t_{PGMS}$	$\overline{PGM}$ setup time		2			$\mu s$
$t_{CEH}$	$\overline{CE}$ hold time		2			$\mu s$
$t_{OEH}$	$\overline{OE}$ hold time		2			$\mu s$

Note 5:  $V_{CC}$  must be applied simultaneously  $V_{PP}$  and removed simultaneously  $V_{PP}$ .

M5M27C102K-15I

1048576-BIT(65536-WORD BY 16-BIT)  
CMOS ERASABLE AND ELECTRICALLY REPROGRAMMABLE ROM

AC WAVEFORMS

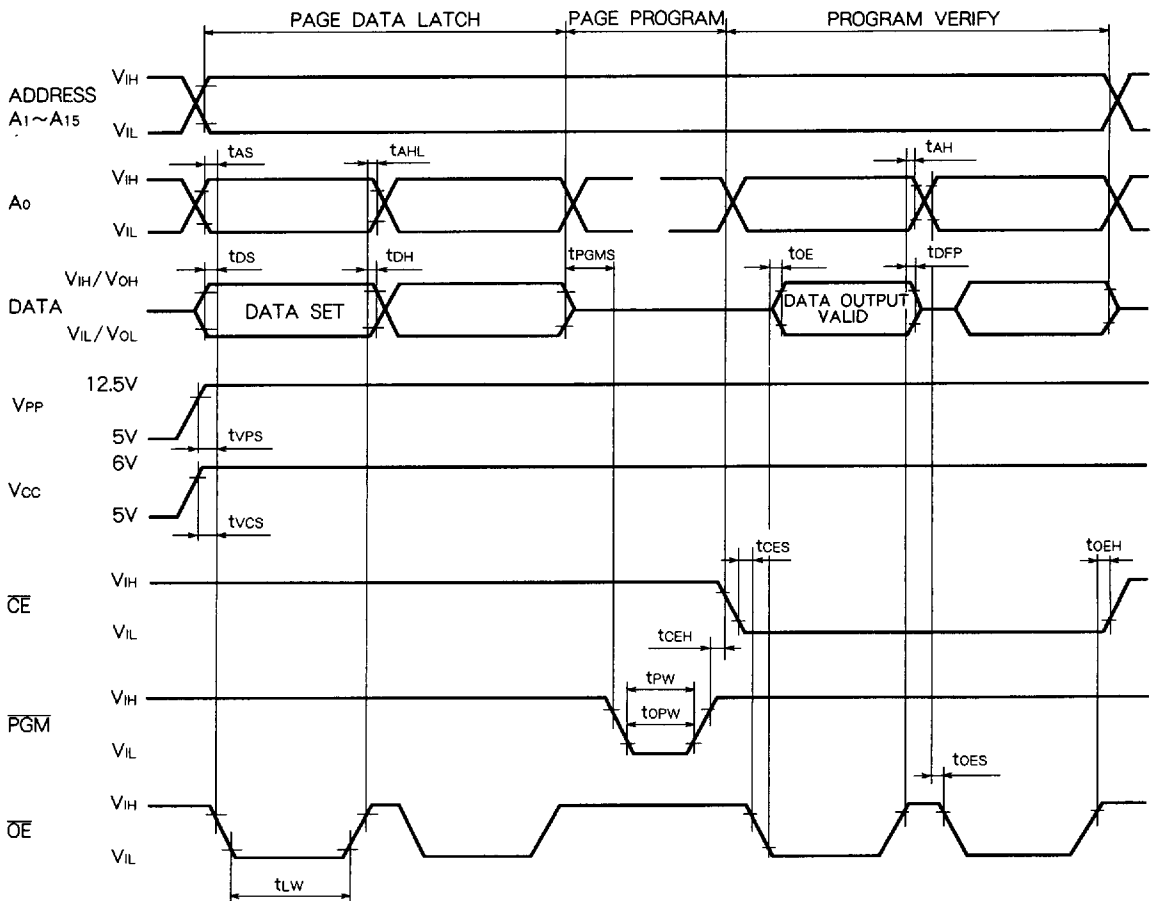

Test condition for A.C. characteristics  
 Input voltage :  $V_{IL} = 0.45V, V_{IH} = 2.4V$   
 Input rise and fall time : (10%~90%) :  $\leq 20ns$   
 Reference voltage at timing measurement : Input, Output "L" = 0.8V, "H" = 2V.

1048576-BIT(65536-WORD BY 16-BIT)  
CMOS ERASABLE AND ELECTRICALLY REPROGRAMMABLE ROM

PAGE PROGRAMMING ALGORITHM  
FLOW CHART

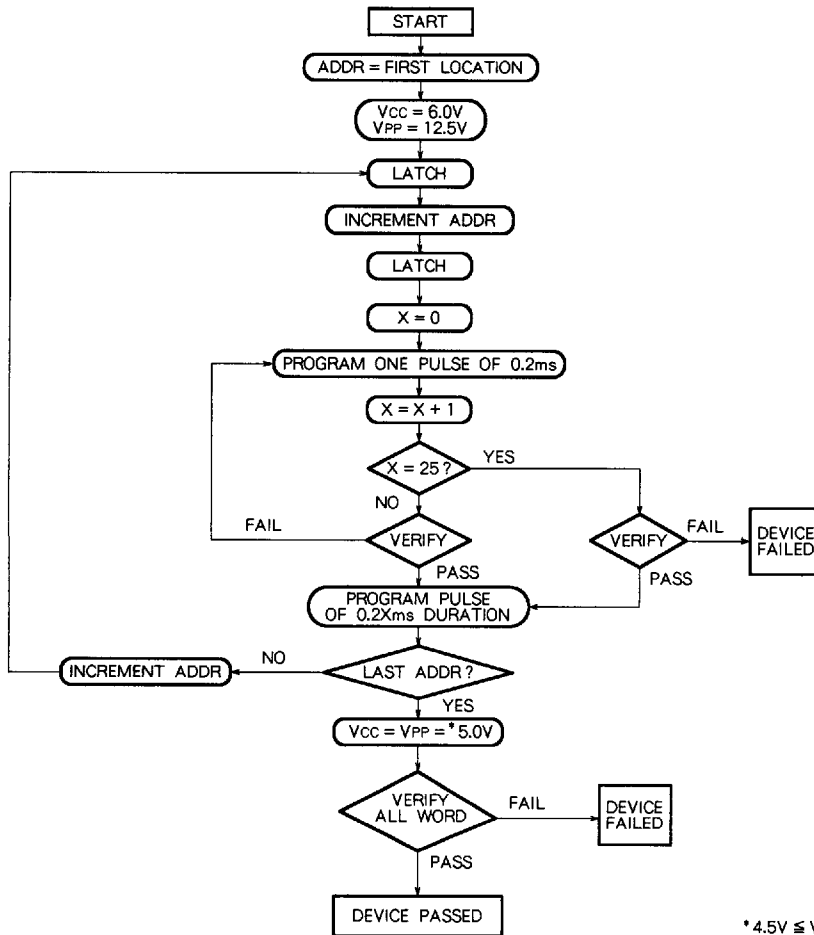

\* 4.5V ≤ Vcc = Vpp ≤ 5.5V

DEVICE IDENTIFIER MODE

The Device Identifier Mode allows the reading of a binary code from the EPROM that identifies the manufacturer and device type.

The EPROM Programmer reads the manufacturer code and the device code and automatically selects the corresponding programming algorithm.

M5M27C102K-15I DEVICE IDENTIFIER CODE

Pins	A0 (21)	D15 (3)	D14 (4)	D13 (5)	D12 (6)	D11 (7)	D10 (8)	D9 (9)	D8 (10)	D7 (12)	D6 (13)	D5 (14)	D4 (15)	D3 (16)	D2 (17)	D1 (18)	D0 (19)	Hex Data
Manufacturer code	V <sub>IL</sub>	0	0	0	0	0	0	0	0	0	0	0	1	1	1	0	0	001C
Device code	V <sub>IH</sub>	0	0	0	0	0	0	0	0	1	0	0	0	0	1	0	1	0085

Note 6: A9 = 12.0 ± 0.5V

A1~A8, A10~A15, CE, OE = V<sub>IL</sub>, PGM = V<sub>IH</sub>  
Vcc = Vpp = 5V ± 10%